

SW-602-N
Waterproof
Wide-Range Temperature
Signage Player

User's Manual

Version 1.0
(March 2026)



Copyright

© 2026 IBASE Technology, Inc. All rights reserved.

No part of this publication may be reproduced, copied, stored in a retrieval system, translated into any language or transmitted in any form or by any means, electronic, mechanical, photocopying, or otherwise, without the prior written consent of IBASE Technology, Inc. (hereinafter referred to as "IBASE").

Disclaimer

IBASE reserves the right to make changes and improvements to the products described in this document without prior notice. Every effort has been made to ensure the information in the document is correct; however, IBASE does not guarantee that this document is error-free. IBASE assumes no liability for incidental or consequential damages arising from misapplication or inability to use the product or the information contained herein, nor for any infringements of the rights of third parties, which may result from its use.

Trademarks

All the trademarks, trade names and brands mentioned herein are used for identification purposes only and may be trademarks and/or registered trademarks of their respective owners.

Compliance

CE

This product has passed CE tests for environmental specifications and limits. This product is in accordance with the directives of the European Union (EU). If users modify and/or install other devices in this equipment, the CE conformity declaration may no longer apply.

FCC

This product has been tested and found to comply with the limits for a Class B device, pursuant to Part 15 of the FCC Rules. These limits are designed to provide reasonable protection against harmful interference in a residential installation. This equipment generates, uses and can radiate radio frequency energy and, if not installed and used in accordance with the manufacturer's instructions, may cause harmful interference to radio communications.

WEEE



This product must not be disposed of as normal household waste, in accordance with the EU directive for waste electrical and electronic equipment (WEEE 2012/19/EU). Instead, it should be disposed of by returning it to a municipal recycling collection point. Check local regulations for disposal of electronic products.

Green IBASE



This product complies with RoHS 2 restrictions, which prohibit the use of certain hazardous substances in electrical and electronic equipment. The following substances must not exceed the specified concentrations:

- Hexavalent chromium: 1,000 ppm
- Poly-brominated biphenyls (PBBs): 1,000 ppm
- Poly-brominated diphenyl ethers (PBDEs): 1,000 ppm
- Cadmium: 100 ppm
- Mercury: 1,000 ppm
- Lead: 1,000 ppm
- Bis(2-ethylhexyl) phthalate (DEHP): 1,000 ppm
- Butyl benzyl phthalate (BBP): 1,000 ppm
- Dibutyl phthalate (DBP): 1,000 ppm
- Diisobutyl phthalate (DIBP): 1,000 ppm

Important Safety Information

Carefully read the precautions before using the device.

Environmental conditions:

- Place the device on a stable and solid surface to prevent it from falling and causing damage.
- Leave plenty of space around the device and do not block the openings for ventilation. Never drop or insert any objects of any kind into the ventilation openings.

Care for your iBASE products:

- Before cleaning the device, turn it off and unplug all cables such as the power cable, as residual electrical current may still be present.
- Use neutral cleaning agents or diluted alcohol to clean the device chassis with a cloth. Then wipe the chassis with a dry cloth.
- Use a computer vacuum cleaner to remove dust and prevent the vents or slots from being clogged.



WARNING

Attention during use:

- Do not place heavy objects on the top of the device.
- Operate this device from the type of power indicated on the marking label. If you are not sure of the type of power available, consult your distributor or your local power company.
- Do not walk on the power cord or allow anything to rest on it.
- If you use an extension cord, make sure that the total ampere rating of the product plugged into the extension cord does not exceed its limits.

Do not disassemble, repair or make any modification to the device. Disassembly, modification, or any attempt at repair could generate hazards and cause damage to the device, even bodily injury or property damage, and will void any warranty.



CAUTION

Danger of explosion if internal lithium-ion battery is replaced by an incorrect type. Replace only with the same or equivalent type recommended by the manufacturer. Dispose of used batteries according to the manufacturer's instructions.

Warranty Policy

- **IBASE standard products:**

IBASE offers a 24-month (2-year) warranty from the date of shipment. If the shipment date cannot be determined, the product serial numbers can be used to determine the approximate shipping date.

- **3rd-party parts:**

12-month (1-year) warranty from delivery for the 3rd-party parts that are not manufactured by IBASE, such as CPU, memory, HDD, power adapter, panel and touchscreen.

* PRODUCTS, HOWEVER, THAT FAIL DUE TO MISUSE, ACCIDENT, IMPROPER INSTALLATION OR UNAUTHORIZED REPAIR SHALL BE TREATED AS OUT OF WARRANTY AND CUSTOMERS SHALL BE BILLED FOR REPAIR AND SHIPPING CHARGES.

Technical Support & Services

1. Visit the IBASE website at www.ibase.com.tw to find the latest information about the product.
2. If you need any further assistance from your distributor or sales representative, prepare the following information of your product and elaborate upon the problem.
 - Product model name
 - Product serial number
 - Detailed description of the problem
 - The error messages in text or in screenshots if there is any
 - The arrangement of the peripherals
 - Software in use (such as OS and application software, including the version numbers)
3. If repair service is required, please log in to the RMA system on the website or contact your distributor or sales representative for assistance.

Table of Contents

Chapter 1	General Information	1
1.1	Introduction	2
1.2	Features.....	2
1.3	Packing List	3
1.4	Specifications.....	3
1.5	Product View.....	5
1.6	Dimensions	7
Chapter 2	Hardware Installation & Motherboard Information	8
2.1	Installation / Replacement.....	9
2.1.1	Memory	10
2.1.2	M.2 Cards.....	11
2.1.3	WiFi /5G Antenna Installation	12
2.2	Setting the Jumpers	13
2.3	Jumper & Connector Locations on Motherboard	14
Chapter 3	Driver Installation	28
3.1	Introduction	29
3.2	Intel® Chipset Software Installation Utility.....	29
3.3	VGA Driver Installation.....	31
3.4	HD Audio Driver Installation	33
3.5	LAN Drivers Installation.....	34
3.6	Intel® ME Drivers Installation	36
3.7	Intel Thunderbolt Drivers Installation	37
Chapter 4	BIOS Setup	38
Appendix	57
A.	I/O Port Address Map.....	58
B.	Interrupt Request Lines (IRQ)	60
C.	Watchdog Timer.....	61

Chapter 1

General Information

The information provided in this chapter includes:

- Features
- Packing List
- Specifications
- Product View
- Dimensions

1.1 Introduction

Powered by 11th Gen Intel® Core™ and Celeron® U-Series processors with support for up to 64GB DDR4-3200 dual-channel memory, the SW-602-N delivers high performance, energy efficiency and reliability for industrial applications. It is equipped with iSMART intelligent energy-saving and Observer remote monitoring technologies, along with versatile connectivity including dual HDMI 2.0 outputs (M25), dual USB 3.1 ports (M12), a Gigabit LAN port (M12), and an M.2 M-Key (2280) expansion slot. Designed with a waterproof, fanless chassis and IP65 protection, the SW-602-N ensures silent operation and durability in harsh conditions, operating stably in wide temperature ranges from -40°C to 70°C.

1.2 Features

- iSMART intelligent energy-saving & Observer remote monitoring technologies
- 11th Gen Intel® Core™ / Celeron® U-Series processors
- 2x DDR4-3200, SO-DIMM, dual channel, Max. 64GB
- 2x HDMI 2.0 (M25 connector)
- 2x USB 3.1 (M12), 1x Gigabit LAN (M12)
- 1x M.2 M-Key (2280)
- Wide-range operating temperature from -40°C ~ 70°C
- Waterproof and fanless design with IP65 rating



1.3 Packing List

The product package should include the items listed below.

- SW-602-N Digital Signage Player
- 2x HDMI Cable (M25 male to HDMI) (optional)
- 2x USB Cable (M12 female to USB type A) (optional)
- 1x RJ45 LAN Cable (M12 female to RJ45) (optional)
- 1x DC Power Cable (M12 female to 3-pin terminal connector) (optional)

1.4 Specifications

Product	SW-602-N
Mainboard	MBD603-i5
CPU	Intel® Core™ i5-1145GRE Processor (8M Cache, up to 4.10 GHz)
CPU Socket	BGA-1449 package
Chipset	SoC Integrated
Memory	2x DDR4-3200, SO-DIMM, dual channel, Max. 64GB
Graphics	Integrated
LAN	1x Gigabit LAN (M12)
Expansion Slots	1x M.2 E-Key (2230) (2x PCI-E x1; USB 2.0) 1x M.2 B-Key (3052) (PCI-E x1; USB 2.0; USB 3.0) 1x internal SIM slot 1x M.2 M-Key (2280) (supports PCI-E Gen3 x4 / SATA3 SSD)
I/O Interface	2x HDMI 2.0 (M25 connector) 2x USB 3.1 (M12) 1x Gigabit LAN (M12) 1x DC power (M12)
Auto Control and Monitoring	Watchdog Timer: 256 segments, 0, 1, 2...255 (sec/min)
Power Requirement	DC Power input 12V~24V (+-10%)
Construction	Aluminum die-casting and heavy-duty steel
Weight	3.6 kg (7.9 lbs)
Chassis Color	Black
Storage	M.2-2280 SATA3 128GB
Power Supply	84W power adapter (optional)
Mounting	Wall mount
Dimensions	217mm(W) x 274mm(D) x 86.5mm(H)

Operating Temperature	-40°C ~ 70°C (-40°F ~ 158°F)
Storage Temperature	-40°C ~ 80°C (-40°F ~ 176°F)
Relative Humidity	10% ~ 90% (non-condensing)
Vibration	3 grms / 5 ~ 500Hz / random operation
Certification	CE, FCC class-B
Operating System	Win10 IoT Enterprise

All specifications are subject to change without prior notice.

1.5 Product View



I/O Interface	2x HDMI 2.0 (M25 connector) 2x USB 3.1 (M12) 1x Gigabit LAN (M12) 1x DC power (M12)
----------------------	--

For pin definitions, please refer to the printed-on chassis

SW-602-N with mounting brackets

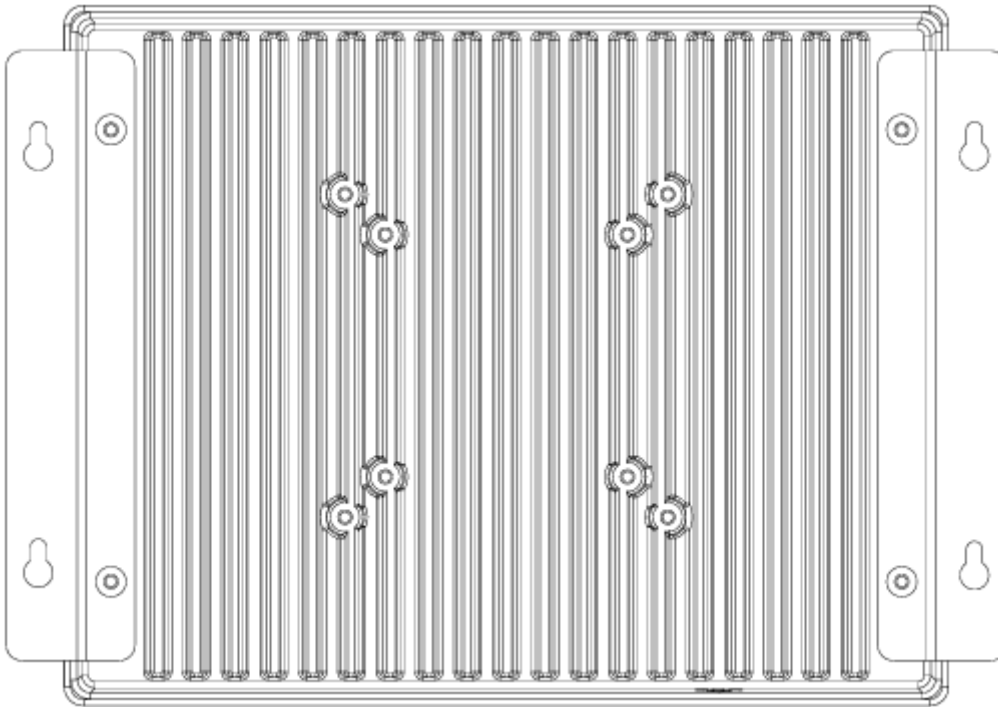

1.6 Dimensions

Unit: mm

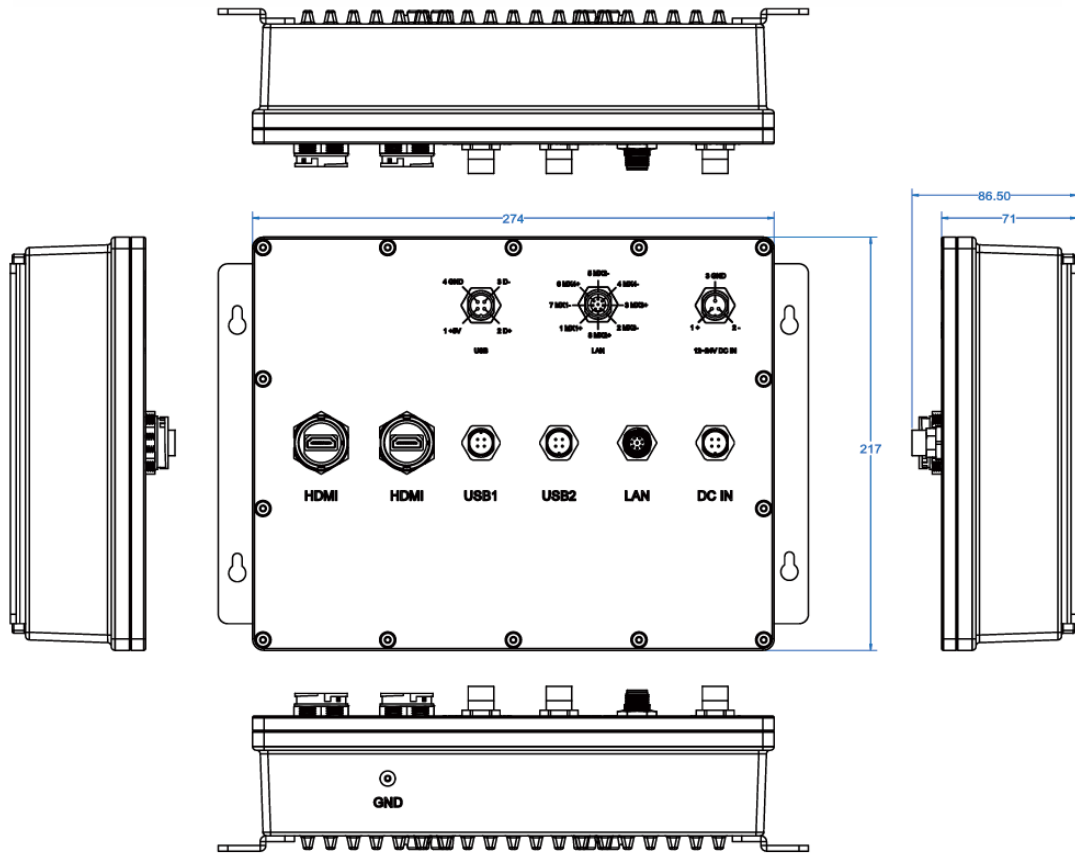

Chapter 2

Hardware Installation & Motherboard Information

The information provided in this chapter includes:

- Installation of memory, M.2 cards and antennas
- Information and locations of connectors

2.1 Installation / Replacement

The following pictures show how to disassemble the SW-602-N. Flip the system to expose the bottom cover and remove the fourteen (14) screws as shown in the picture below. Afterwards, you will be able to access the sockets and connectors that will be discussed in the following pages.

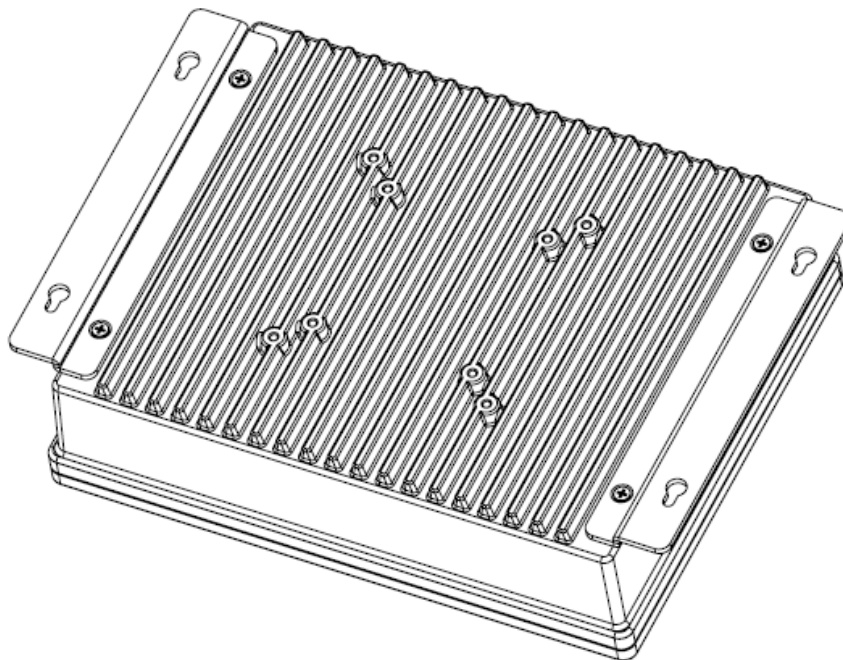
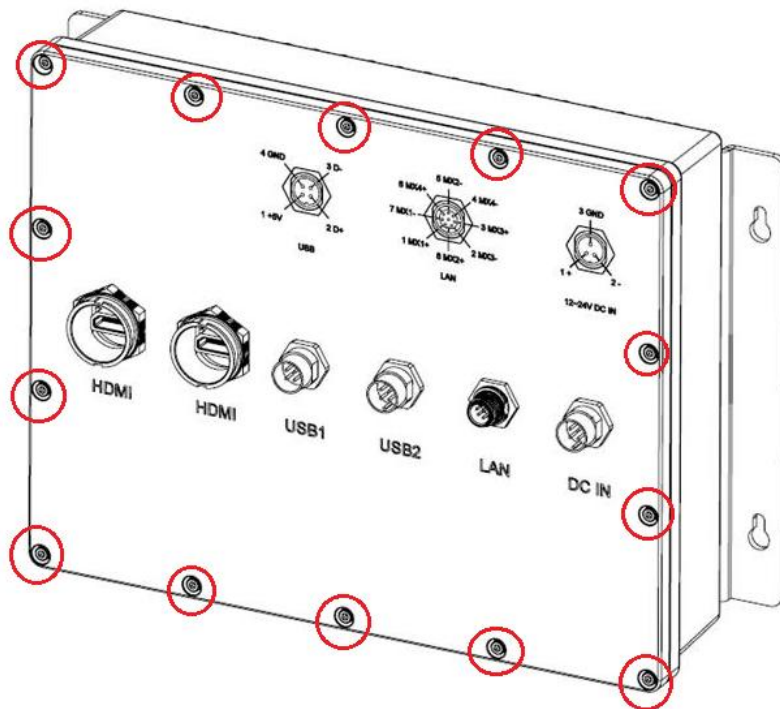

2.1.1 Memory

To install memory modules, locate the memory slot on the motherboard and perform the following steps:

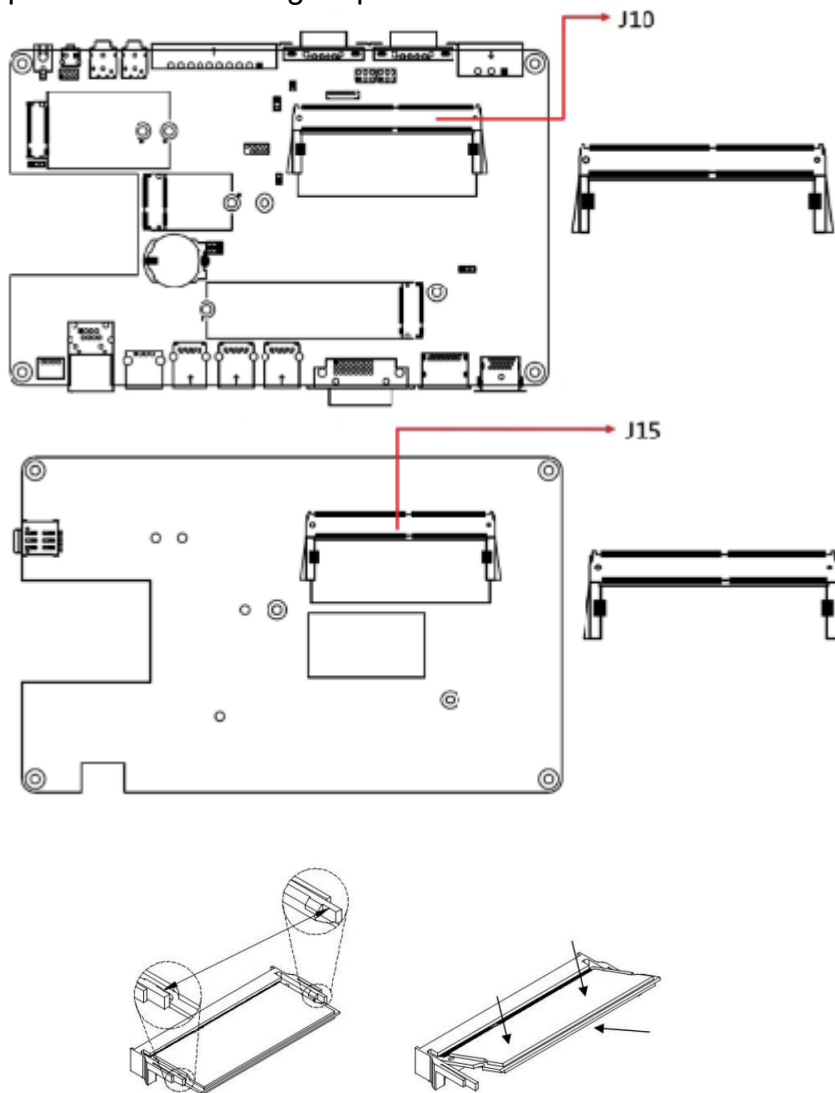

1. Align the key of the memory module with that on the memory slot and insert the module slantwise.
2. Gently push the module in an upright position until the clips of the slot close to hold the module in place when the module touches the bottom of the slot.

To remove the module, press the ejector tabs outwards with your fingertips to eject the module.

2.1.2 M.2 Cards

1. Locate the M.2 slot inside the device.

Align the key of the M.2 card to the interface, and insert the card slantwise. Fix the M.2 card with a screw.

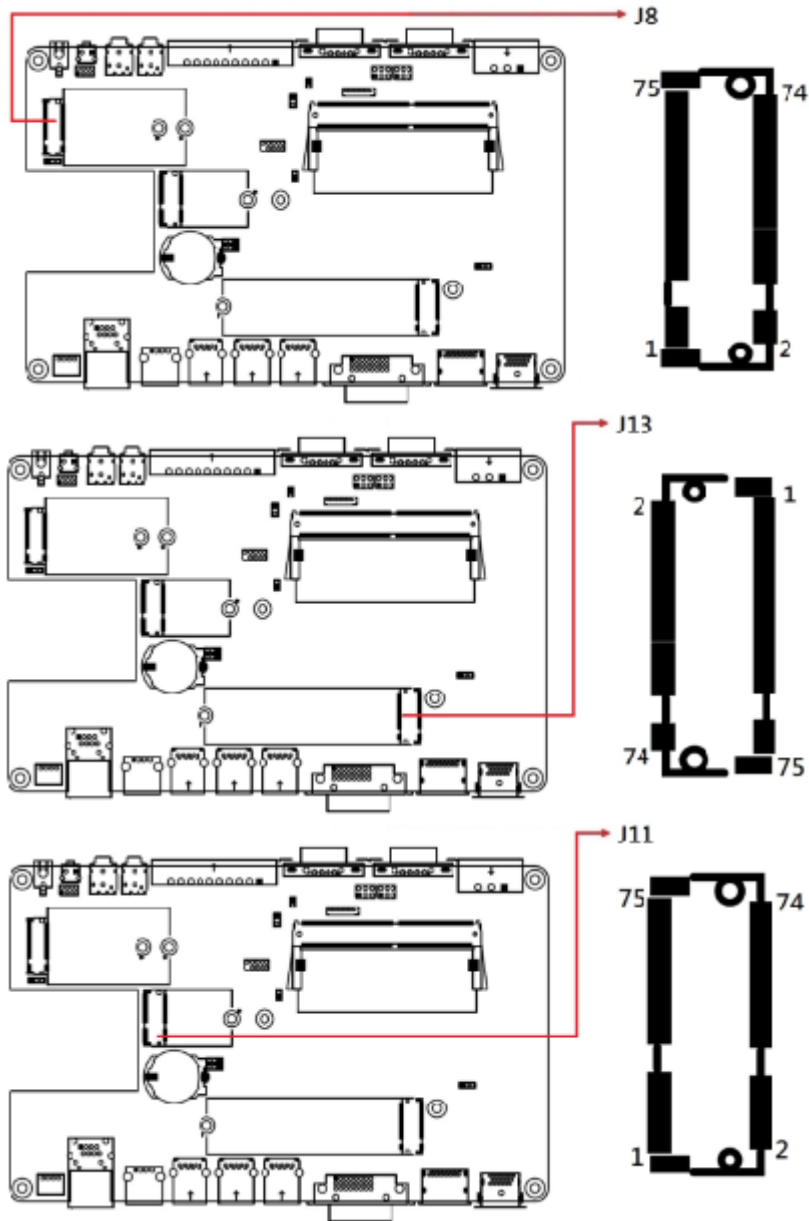

M.2 Slots	Description
J8	M.2 B-Key [supports USB 2.0 & 3.0 & PCIe]
J13	M.2 M-Key
J11	M.2 E-Key [supports USB 2.0 & PCIe]

2.1.3 WiFi /5G Antenna Installation

Thread the WiFi / 5G antenna extension cable through an antenna hole of the front I/O cover and fasten the antenna as shown below. Then apply adhesive to the edge of the hex nut behind the front I/O cover to prevent the extension cable from falling if the cable becomes loose.

1. Thread and fasten the hex nut and the washer. Then install the antenna.

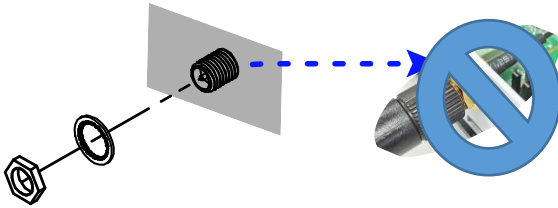

2. Apply adhesive around here.

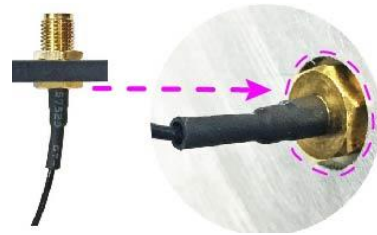

Info: The diameter of the nut is around 6.35 mm (0.25"-36UNC).

2.2 Setting the Jumpers

Jumpers are short-length conductors consisting of several metal pins with a non-conductive base mounted on the circuit board. Jumper caps are used to have functions enabled or disabled. If a jumper has 3 pins, you can connect either PIN1 to PIN2 or PIN2 to PIN3 by shorting.

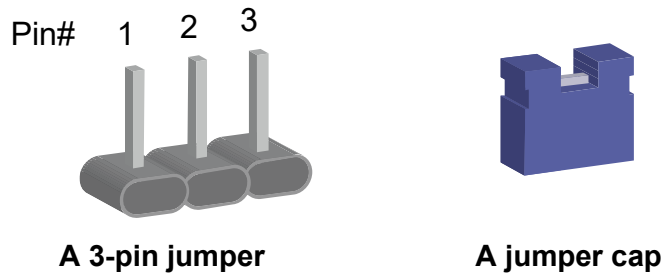

Refer to the illustration below to set jumpers.

Pin closed	Oblique view	Illustration
Open		
1-2		
2-3		

When two pins of a jumper are encased in a jumper cap, this jumper is **closed**, i.e. turned **On**.

When a jumper cap is removed from two jumper pins, this jumper is **open**, i.e. turned **Off**.

2.3 Jumper & Connector Locations on Motherboard

Motherboard: MBD603

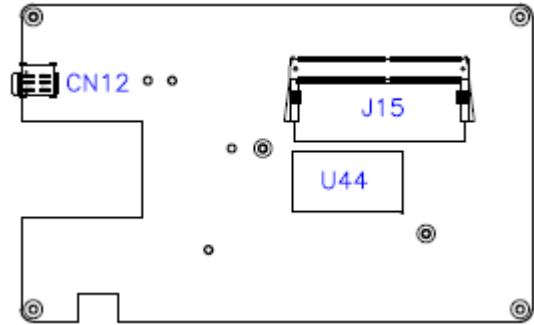
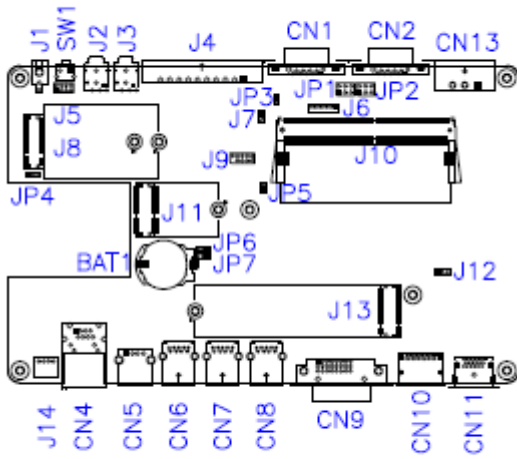

MBD603 – top and I/O

MBD603 – back and I/O

2.3.1 Jumper Quick Reference

Jumper / Switch	Function
JP1 / JP2	COM1 / COM2 RI Power
JP3	AT/ATX Mode Selection
JP6	Clear ME
JP7	Clear RTC

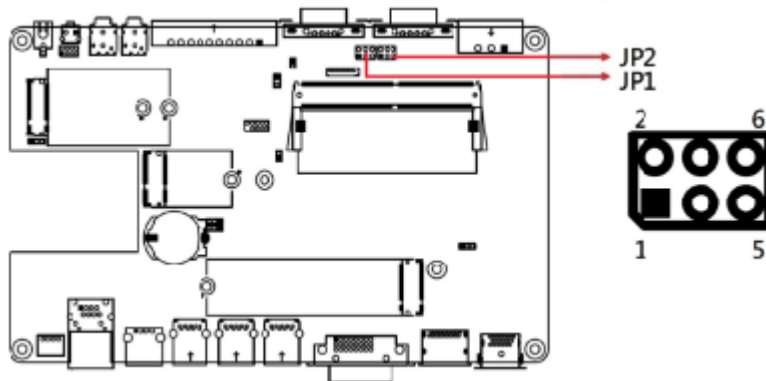

2.3.2 JP1 / JP2: COM1 / COM2 RI Power



Function	Pin closed	Illustration
12V	1-3	
Normal (default)	3-4	
5V	3-5	

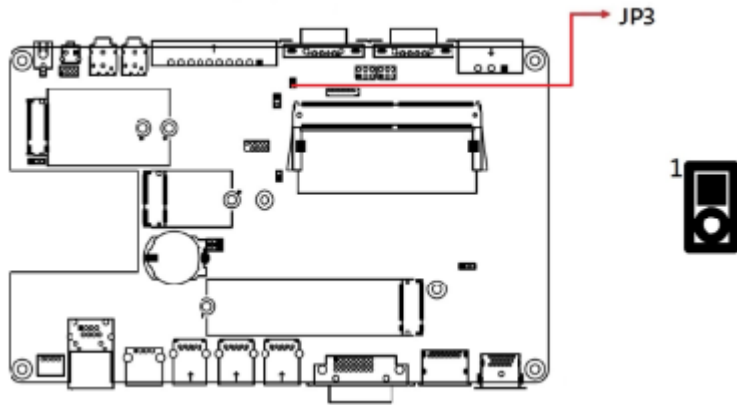

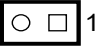
2.3.3 JP3: AT/ATX Mode Selection



JP3	Function	Pin closed
 1	ATX	Open
 1	AT	Closed

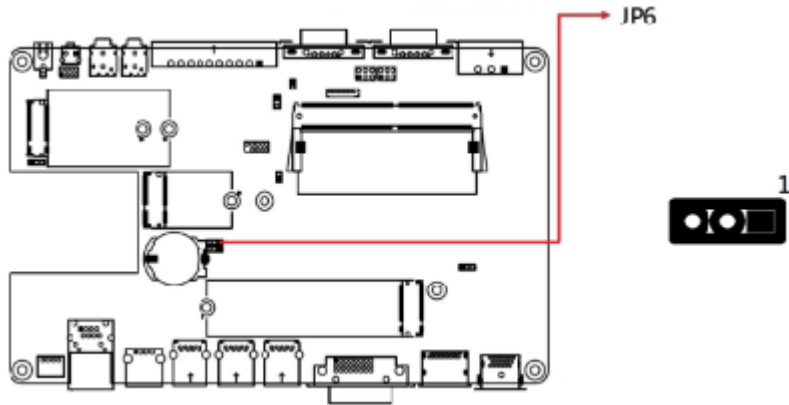

2.3.4 JP6: Clear ME

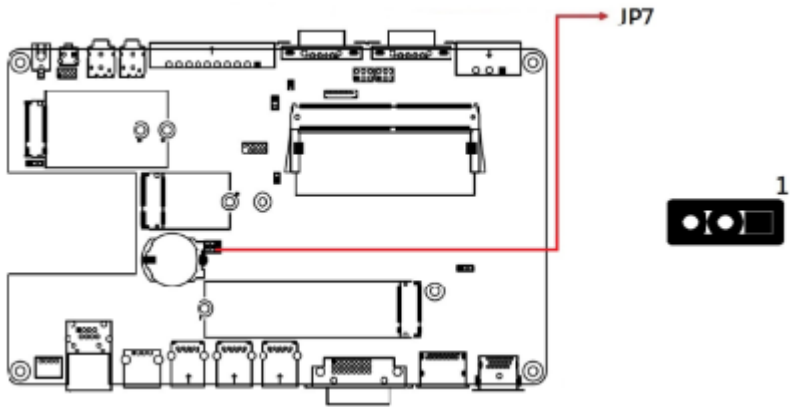

JP6	Function	Pin closed
 1	Normal (Default)	1-2
 1	Clear CMOS	2-3

2.3.5 JP7: Clear RTC

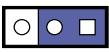

JP7	Function	Pin closed
 1	Normal (Default)	1-2
 1	Clear RTC	2-3

2.3.6 Connector Quick Reference

Connector	Function
CN1	COM1 Connector (supports RI with 5V/12V)
CN2	COM2 Connector (supports RI with 5V/12V)
CN4	I226 RJ45 Connector
CN5	USB 2.0 Connector
CN6, CN7, CN8	USB 3.1 Connector
CN9	DVI-D Connector
CN10	Display++ Connector
CN11	HDMI 2.0 Connector
CN12	SIM Card Slot
CN13	DC_IN Connector 12V~24V ($\pm 10\%$) DC Power input
SW1, J1	Power Button
J2	Line_In Jack
J3	Line_Out Jack
J4	Digital IO Connector
J5	Front Panel
J6	ESPI Debug Connector
J8	M.2 B-Key [supports USB 2.0 & 3.0 & PCIe]
J9	SPI Flash Connector
J10/J15	DDR4 Sockets
J11	M.2 E-Key [supports USB 2.0 & PCIe]
J13	M.2 M-Key
J14	iSMART Flash Connector
LED1	iSMART LED
LED2	HDD LED
LED3	Power LED

Remarks: Internal motherboard connectors (for reference only)

2.3.7 CN1: COM1 Connector (supports RI with 5V/12V)

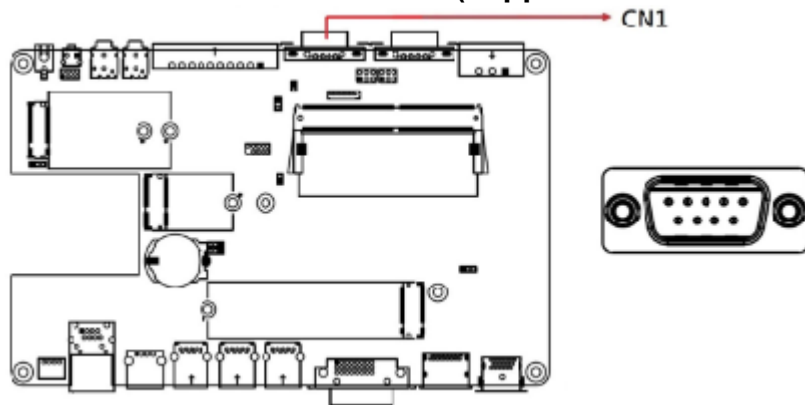

2.3.8 CN2: COM2 Connector (supports RI with 5V/12V)

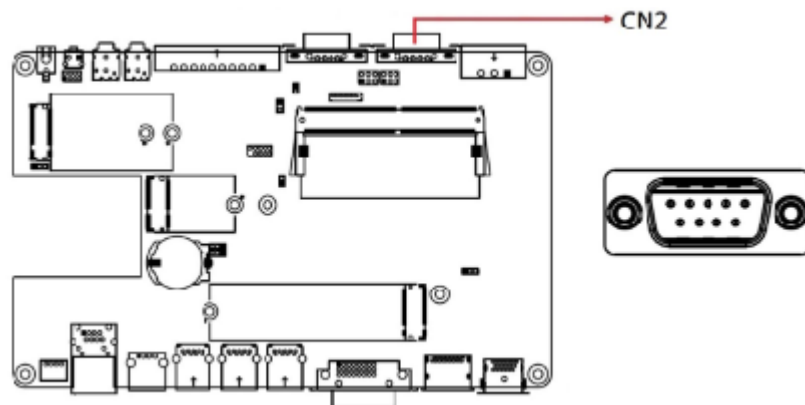

2.3.9 CN4: I226 RJ45 Connector

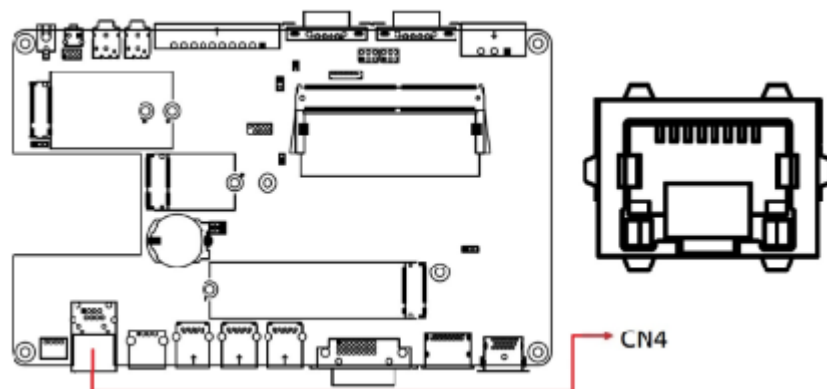

2.3.10 CN5: USB 2.0 Connector

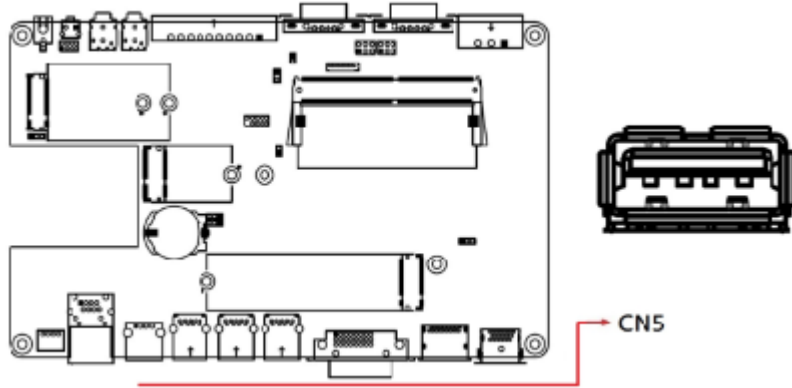

2.3.11 CN6, CN7, CN8: USB 3.1 Connector

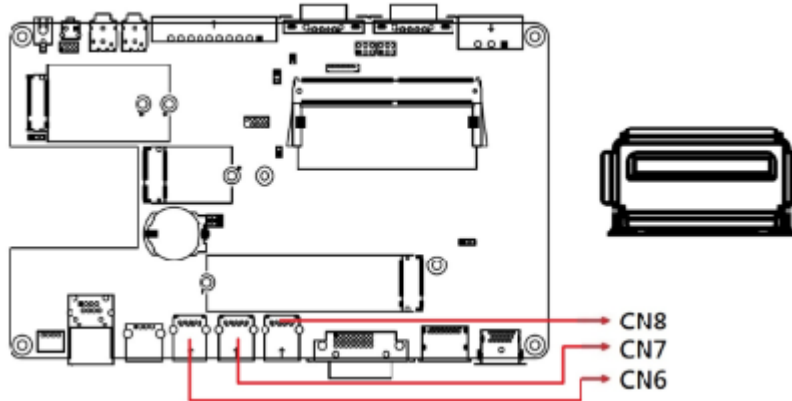

2.3.12 CN9: DVI-D Connector

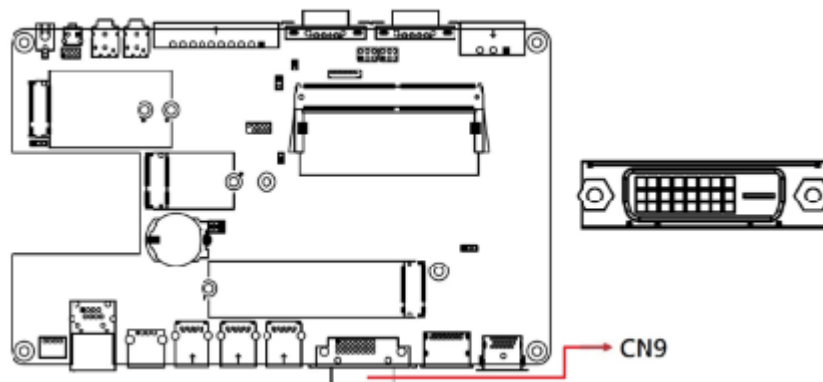

2.3.13 CN10: Display++ Connector

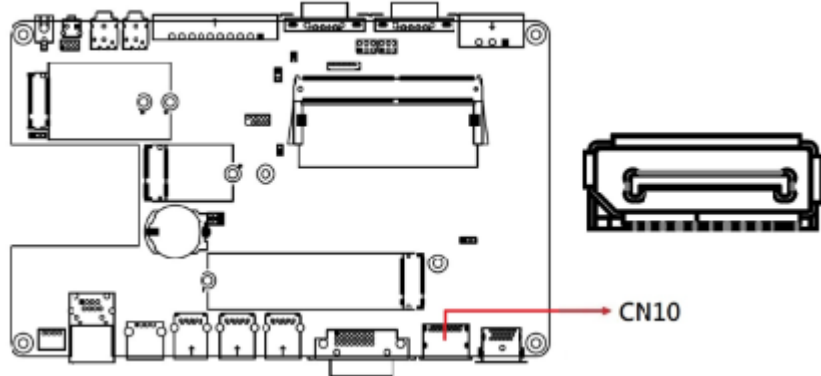

2.3.14 CN11: HDMI 2.0 Connector

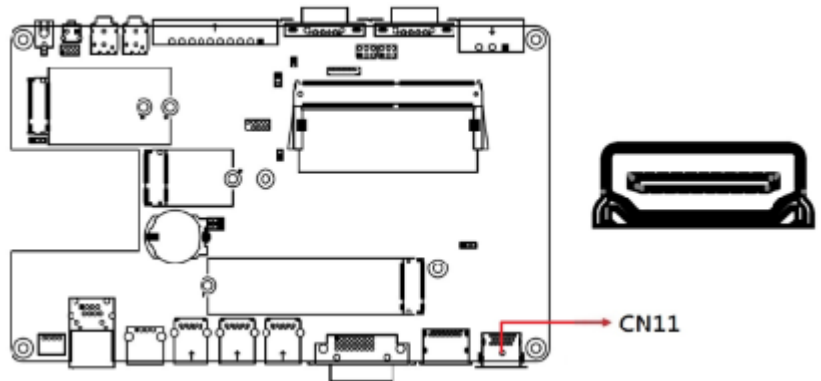

2.3.15 CN12: SIM Card Slot

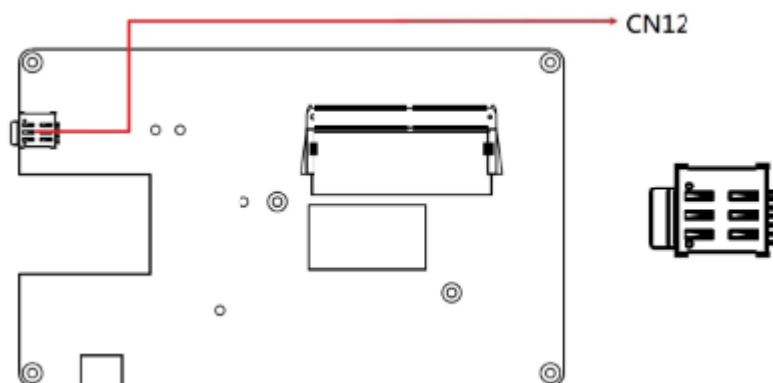

2.3.16 CN13: DC_IN Connector 12V~24V (+-10%) DC Power input

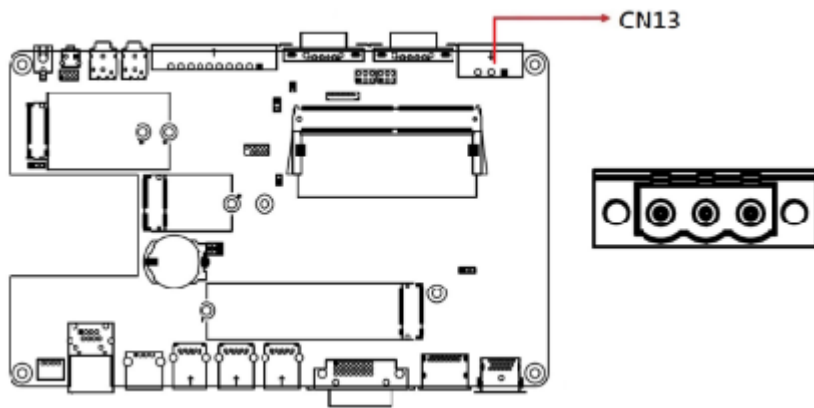

2.3.17 SW1, J1: Power Button

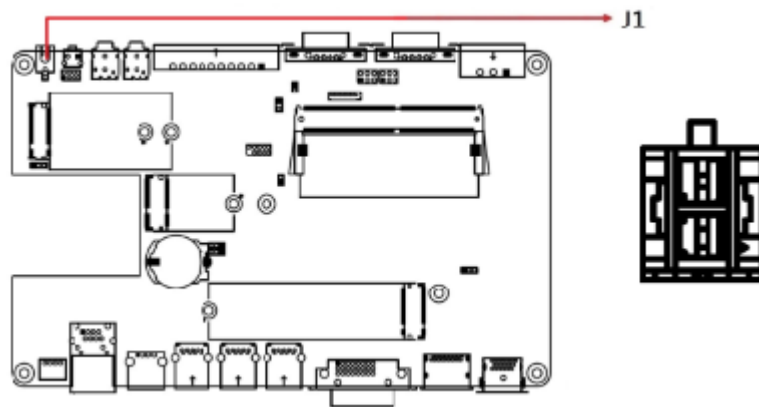

2.3.18 J2: Line_In Jack

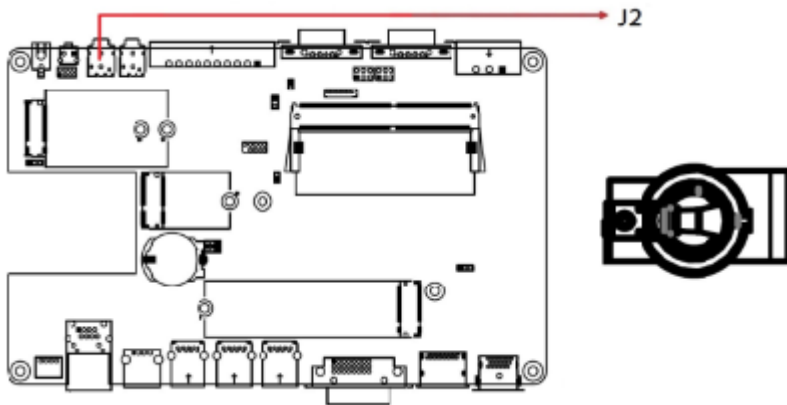

2.3.19 J3: Line_Out Jack

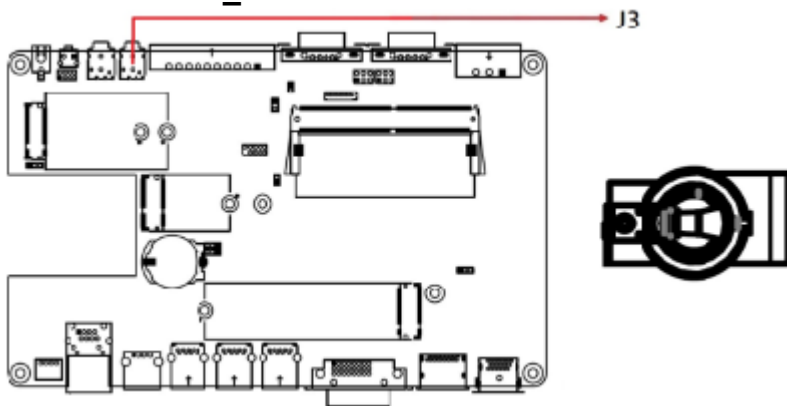

2.3.20 J4: Digital IO Connector

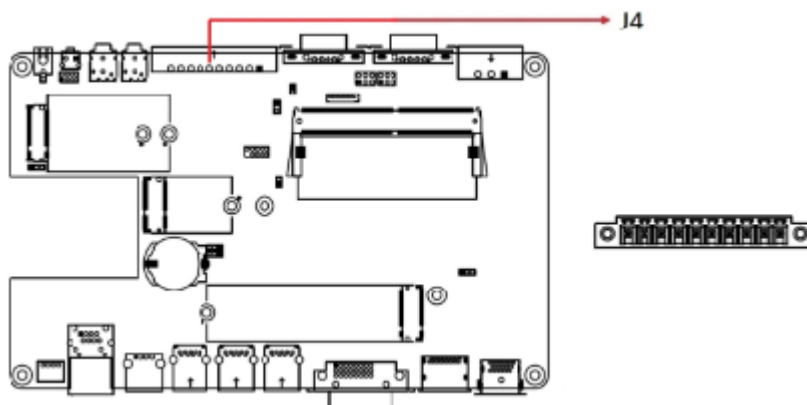

2.3.21 J5: Front Panel Connector

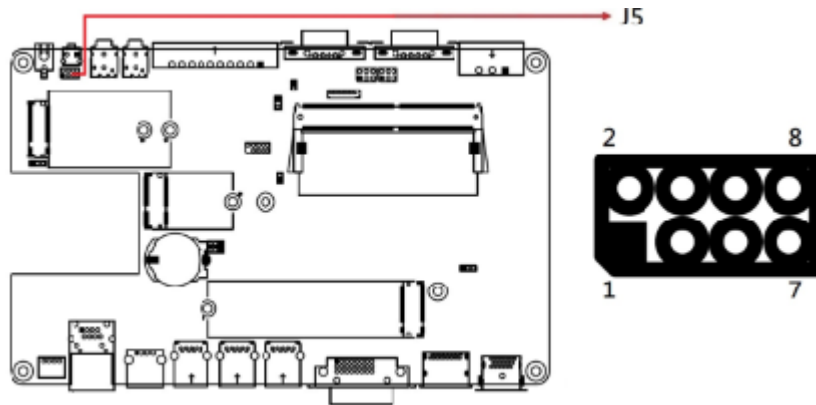

Pin	Signal Name	Pin	Signal Name
1	Power BTN	2	Power BTN
3	HDD LED+	4	HDD LED-
5	Reset BTN	6	Reset BTN
7	Power LED+	8	Power LED-

2.3.22 J6: ESPI Debug Connector

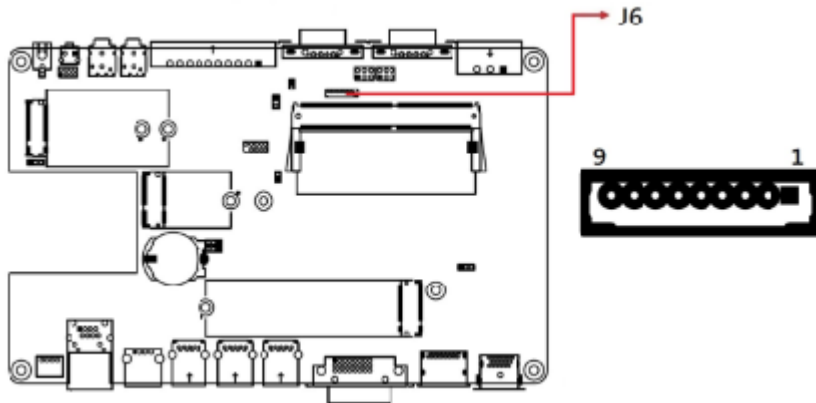

2.3.23 J8: M.2 B-Key

Note: Supports USB 2.0 & 3.0 & PCIe (for 4G 5G module)

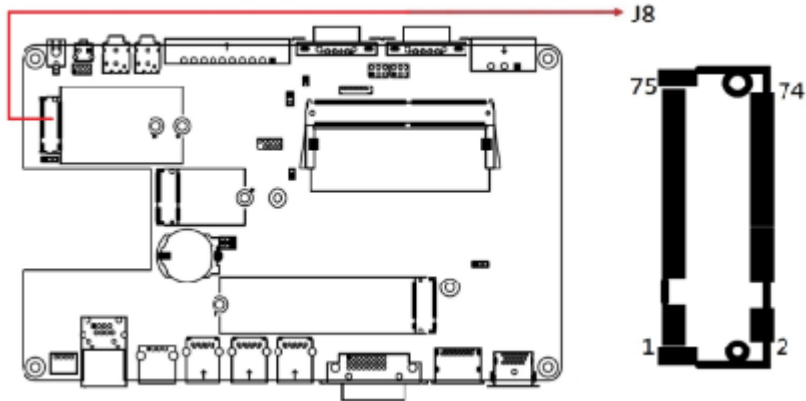

2.3.24 J9: SPI Flash Connector

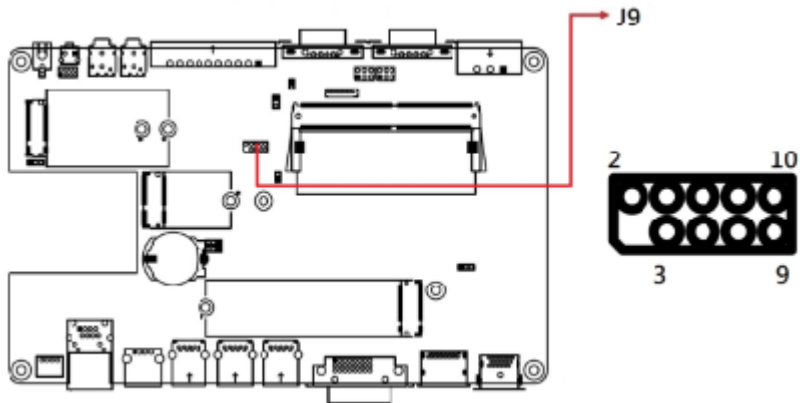

2.3.25 J10/J15: DDR4 Sockets

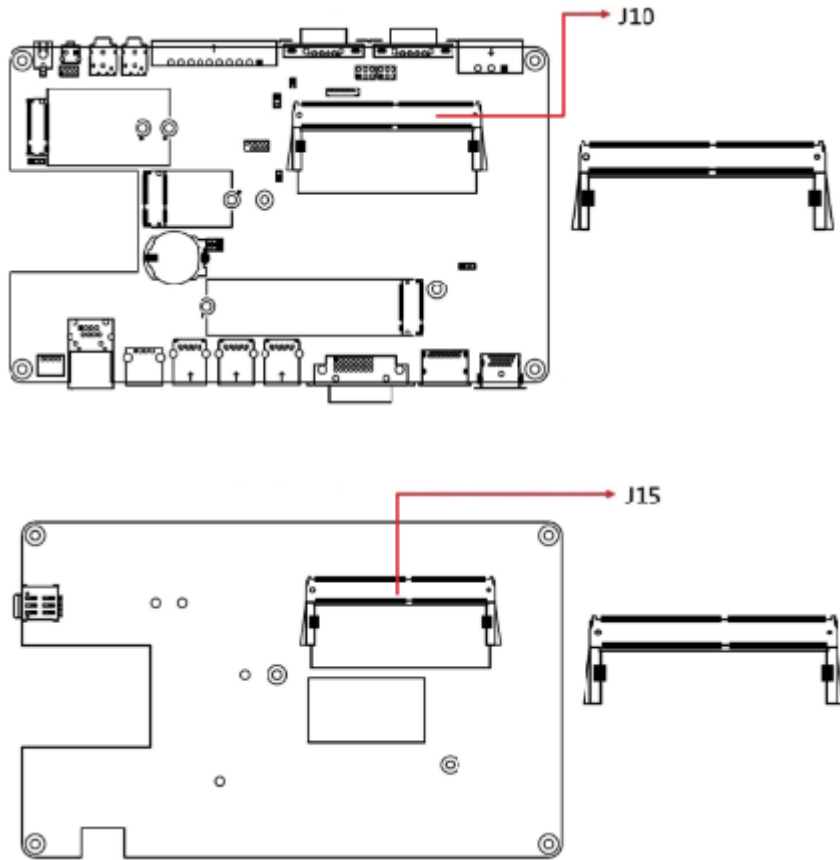

2.3.26 J11: M.2 E-Key

Note: Supports USB 2.0 & PCIe (for WiFi module)

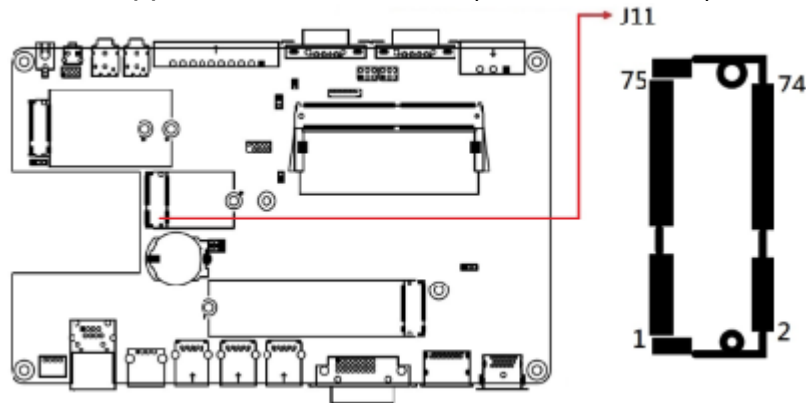

2.3.27 J13: M.2 M-Key

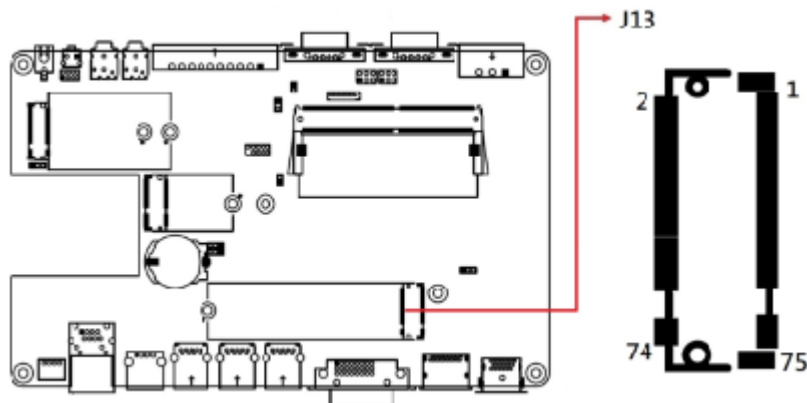

2.3.28 J14: iSMART Flash Connector

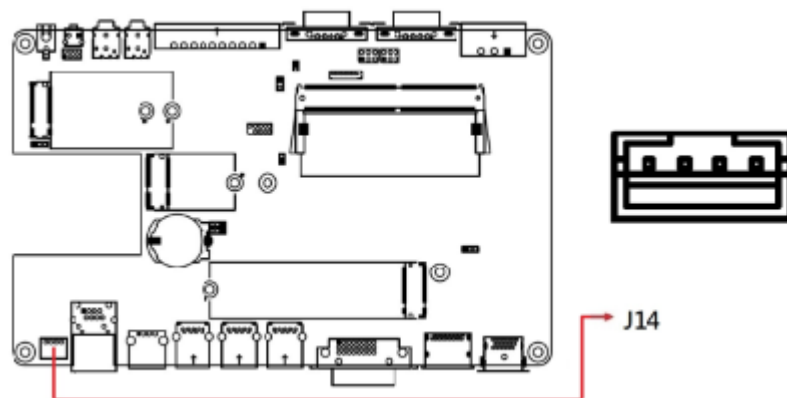

2.3.29 LED1: iSMART LED

2.3.30 LED2: HDD LED

2.3.31 LED3: Power LED

Chapter 3

Driver Installation

The information provided in this chapter includes:

- Intel Chipset Software Installation Utility
- VGA Driver Installation
- HD Audio Driver Installation
- LAN Drivers Installation
- Intel ME Drivers Installation
- Intel Thunderbolt Drivers Installation

3.1 Introduction

This section describes the installation procedures of the software drivers. The software drivers are available at the IBASE website. Go to the download page of the product. Copy the compressed drivers file to your computer. Double click the file to decompress it. Run “CDGuide” to go to the main drivers page as shown in the next steps.

Note: After installing the Windows operating system, install the Intel® Chipset Software Installation Utility before proceeding with drivers installation.

3.2 Intel® Chipset Software Installation Utility

1. Click **Intel** on the left pane and then **Intel(R) TigerLake-U Chipset Drivers**. Click **Intel(R) Chipset Software Installation Utility**.



- When the Welcome screen to the Intel® Chipset Device Software appears, click **Next** to continue.



- Accept the software license agreement.

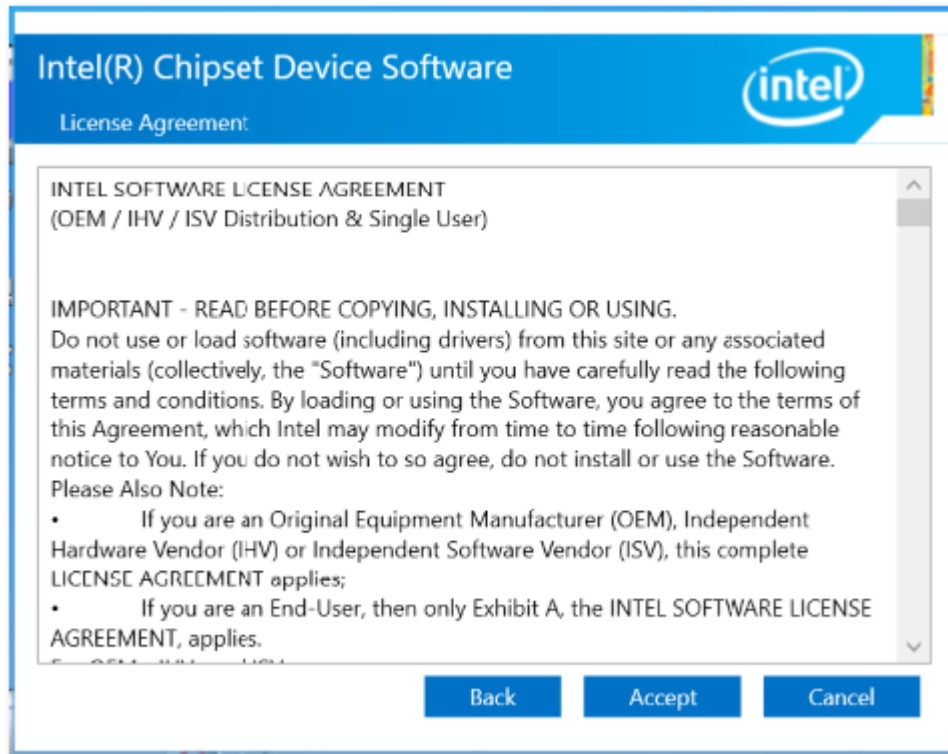

- On the Readme File Information screen, click **Install**.

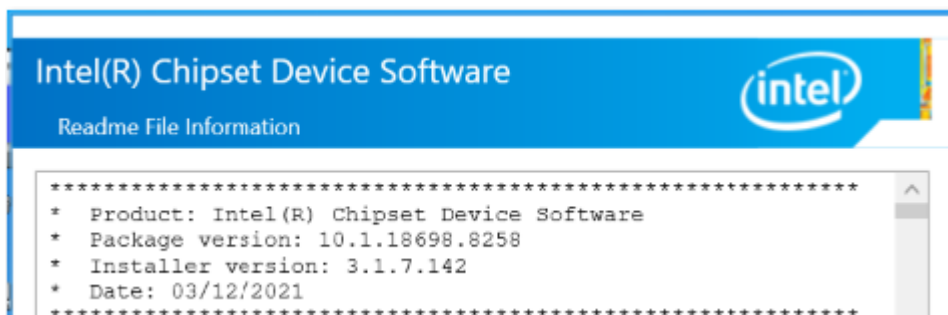

- After the installation has been completed, press **Finish** to complete the setup process.

3.3 VGA Driver Installation

1. Click **Intel** on the left pane and then **Intel(R) TigerLake-U Chipset Drivers**. Click **Intel(R) HD Graphics Driver**.



2. On the following screen, click **Begin Installation**.

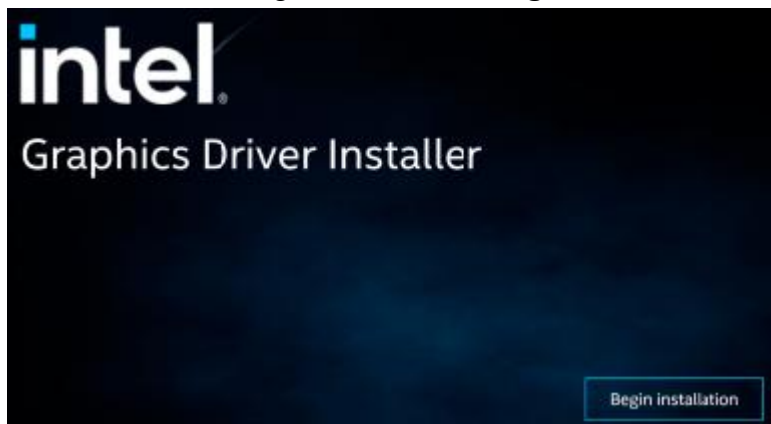

3. Click **I agree** to accept the license agreement.

4. On the next screen, click **Start**.



5. After the installation has been completed, click **Finish**.

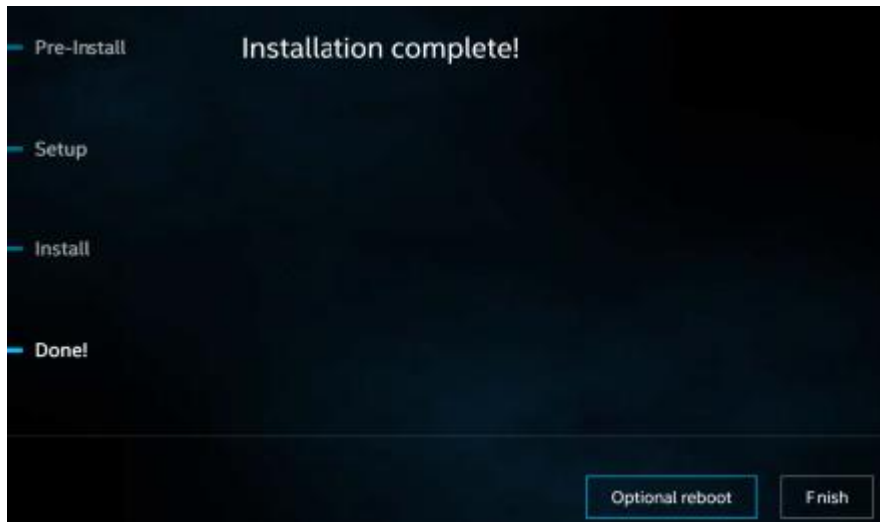

3.4 HD Audio Driver Installation

1. Click **Intel** on the left pane and then **Intel(R) TigerLake-U Chipset Drivers**. Click **Realtek High Definition Audio Driver**.



2. On the Welcome screen, click **Next** to continue.



3. When the InstallShield Wizard has successfully installed the Realtek Audio Driver, click **Finish** to complete setup.

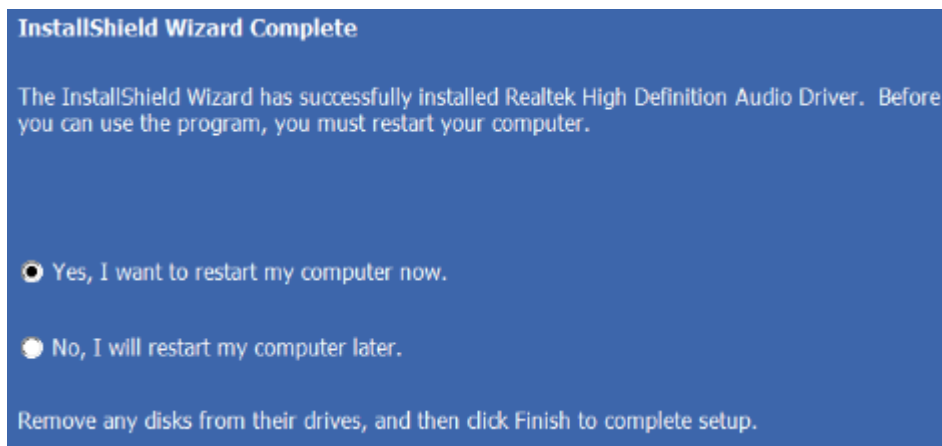

3.5 LAN Drivers Installation

1. Click **Intel** on the left pane and then **Intel(R) TigerLake-U Chipset Drivers**. Click **Intel(R) PRO LAN Network Drivers**.



2. Choose **Install Drivers and Software**.

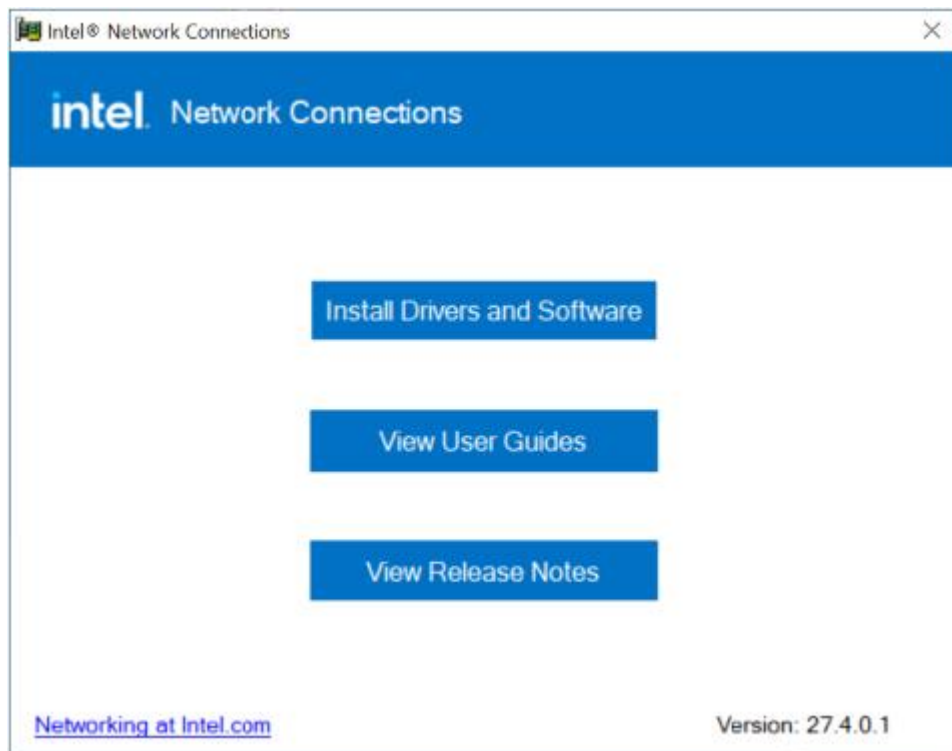

3. In the Welcome screen to the install wizard for Intel(R) Network Connections, click **Next**.

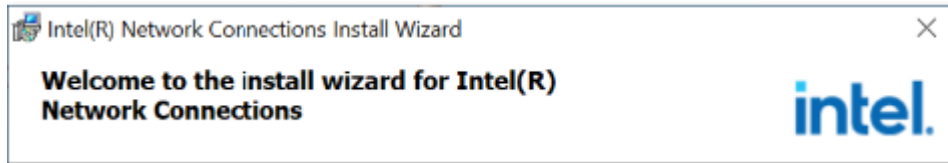

4. Accept the terms in the license agreement and click **Next**.

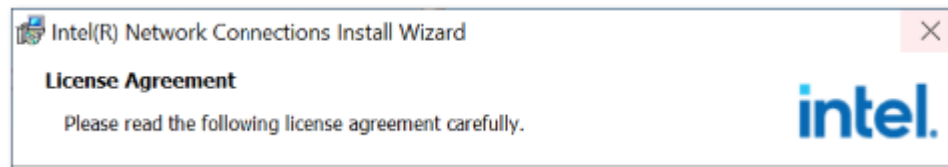

5. In the *Setup Options* screen, click **Next**.

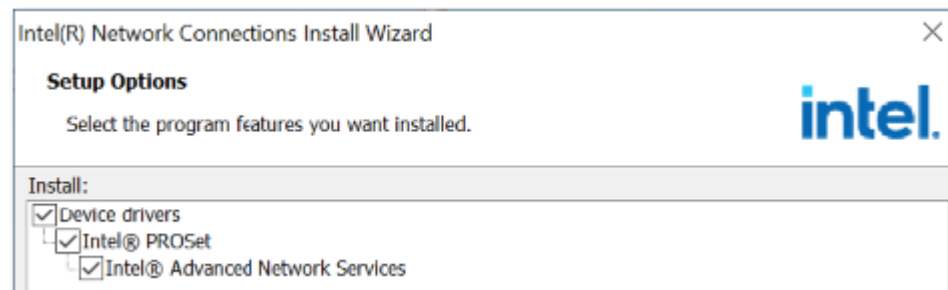

6. Click **Install** to begin installation.

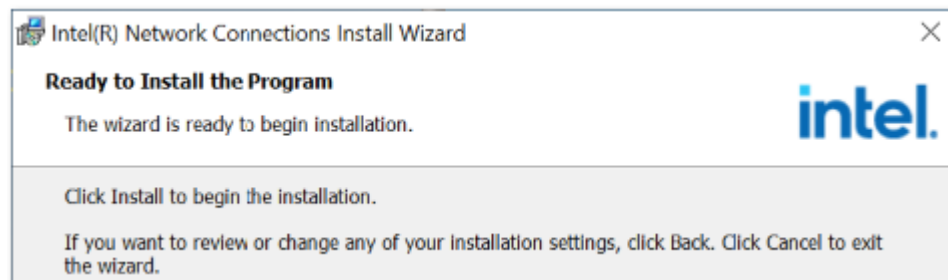

7. Click **Finish** when Install wizard has completed the installation.



3.6 Intel® ME Drivers Installation

1. Click **Intel** on the left pane and then **Intel(R) TigerLake-U Chipset Drivers**. Click **Intel(R) ME 15.x Drivers**.



2. When the welcome screen to the Intel® Management Engine Components appears, click **Next**.



3. Accept the license agreement and click Next.

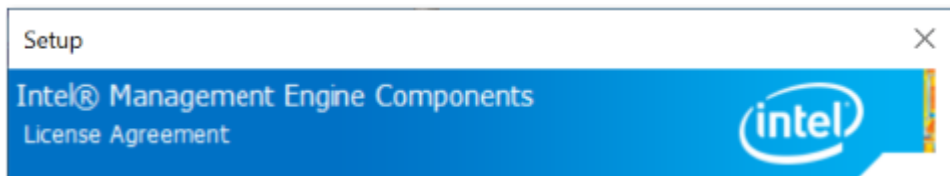

4. On the Setup's Destination Folder screen, click **Next**.
5. After the components have been completely installed, click **Finish**.

You have successfully installed the following components:

- Intel® Management Engine Interface
- Local Management Service
- Intel® Dynamic Application Loader
- Intel® Trusted Connect Service

3.7 Intel Thunderbolt Drivers Installation

1. Click **Intel** on the left pane and then **Intel(R) TigerLake-U Chipset Drivers**. Click **Intel(R) Thunderbolt Drivers**.



2. Agree to the license terms and conditions and click **Install**.



3. Restart the computer after installation has been completed.

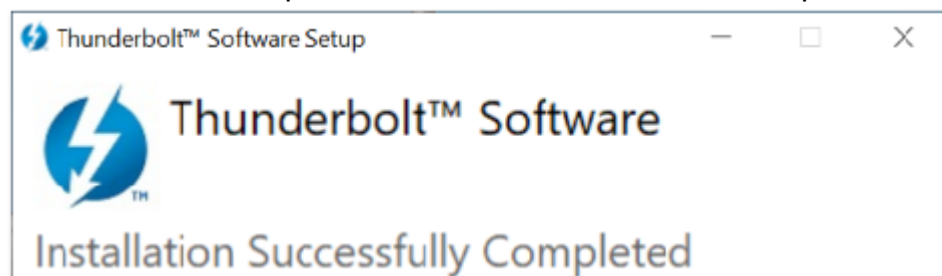

Chapter 4

BIOS Setup

This chapter describes the different settings available in the AMI BIOS. The topics covered in this chapter are as follows:

- Main Settings
- Advanced Settings
- Chipset Settings
- Security Settings
- Boot Settings
- Save & Exit

4.1 Introduction

The BIOS (Basic Input/Output System) installed in the ROM of the system supports Intel® processors. The BIOS provides critical low-level support for standard devices such as disk drives and serial ports. It also provides password protection as well as special support for detailed fine-tuning of the chipset controlling the entire system.

4.2 BIOS Setup

The BIOS provides a Setup utility program for specifying the system configurations and settings. The BIOS ROM of the system stores the Setup utility. When you turn on the computer, the BIOS is immediately activated. Pressing the key immediately allows you to enter the Setup utility. If you are a little bit late pressing the key, POST (Power On Self Test) will continue with its test routines, thus preventing you from invoking the Setup.

If you still need to enter Setup, restart the system by pressing the "Reset" button or simultaneously pressing the <Ctrl>, <Alt> and <Delete> keys. You can also restart by turning the system Off and back On again.

The following message will appear on the screen:

```
Press <DEL> to Enter Setup
```

In general, press the arrow keys to highlight items, <Enter> to select, the <PgUp> and <PgDn> keys to change entries, <F1> for help, and <Esc> to quit.

When you enter the BIOS Setup utility, the *Main Menu* screen will appear on the screen. The Main Menu allows you to select from various setup functions and exit choices.

Warning: It is strongly recommended that you avoid making any changes to the chipset defaults.

These defaults have been carefully chosen by both AMI and the system manufacturer to provide the absolute maximum performance and reliability. Changing the defaults could make the system unstable and crash in some cases.

4.3 Main Settings

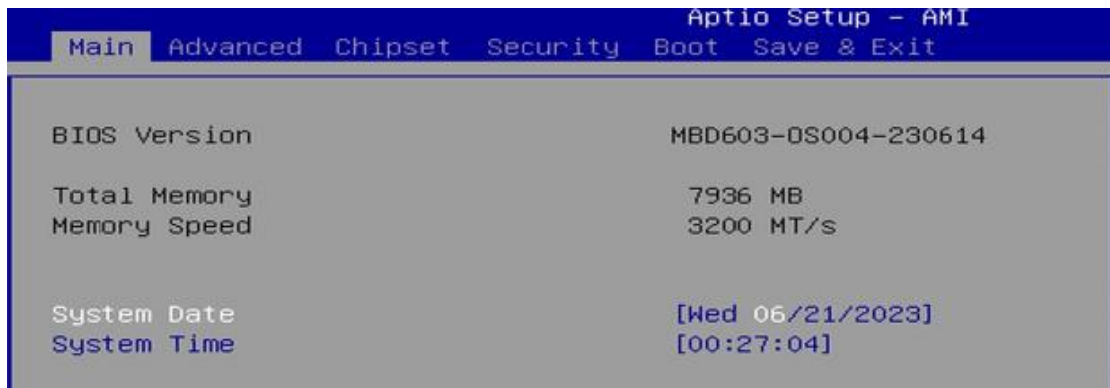

BIOS Setting	Description
System Date	Sets the date. Use the <Tab> key to switch between the date elements.
System Time	Set the time. Use the <Tab> key to switch between the time elements.

4.4 Advanced Settings

This section allows the configuration of the system and the selection of the system features according to your preference.



4.4.1 Connectivity Configuration

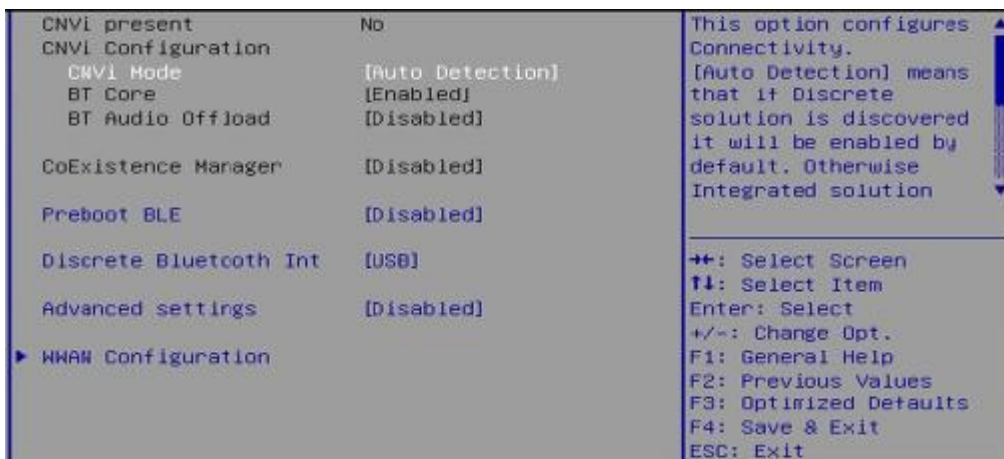

BIOS Setting	Description
CNVI Mode	This option configures Connectivity. Auto Detection – means that if Discrete solution is discovered, it will be enabled by default. Otherwise Integrated solution.
Preboot BLE	This will be used to enable Preboot Bluetooth function.
Discrete Bluetooth Int.	Seriallo UART0 needs to be enabled to select BT interface.
Advanced settings	Configure ACPI objects for wireless devices
WWAN Configuration	Configure WWAN related options.
WWAN Device	Select the M.2 WWAN Device options to enable 4G – 7360/756) (Intel), 5G – M80 (MediaTek) Modems

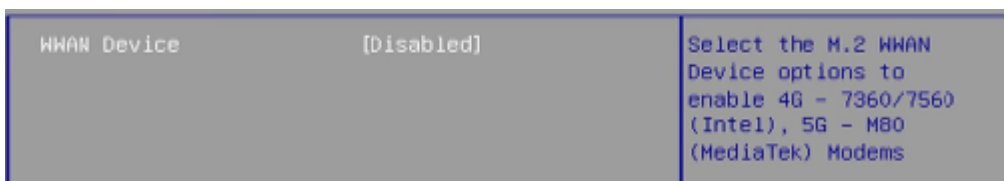

4.4.2 CPU Configuration

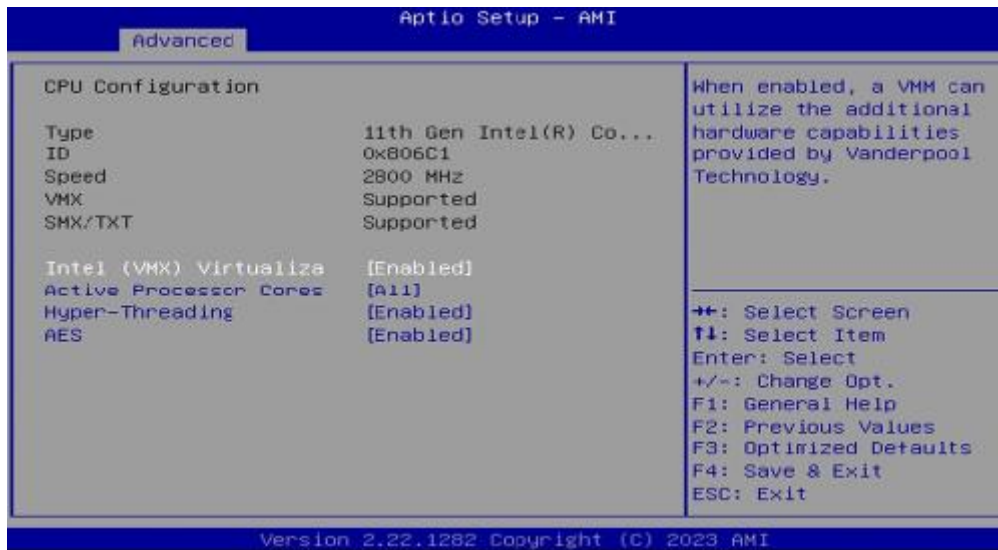

BIOS Setting	Description
Intel (VMX) Virtualization Technology	When enabled, a VMM can utilize the additional hardware capabilities provided by Vanderpool Technology.
Active Processor Cores	Number of cores to enable in each processor package.
Hyper-Threading	Enable/Disable Hyper-Threading Technology.
AES	Enable/Disable AES (Advanced Encryption Standard)

4.4.3 Power & Performance

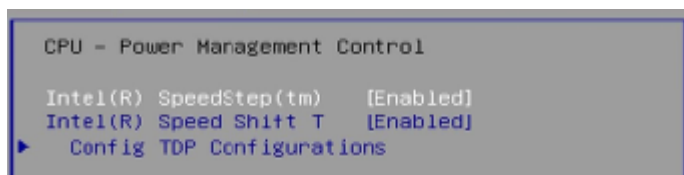

BIOS Setting	Description
CPU – Power Management Control	CPU – Power Management Control Options
Intel(R) SpeedStep(tm)	Allows more than two frequency ranges to be supported
Intel(R) Speed Shift Technology	Enable/Disable Intel(R) Speed Shift Technology support. Enabling will expose the CPPC v2 interface to allow for hardware controlled P-states
Configurable TDP Boot	Configurable TDP Mode as Nominal / Up / Down / Deactivate TDP selection. Deactivate option will set MSR to Nominal and MMIO to Zero.

4.4.4 PCH-FW Configuration

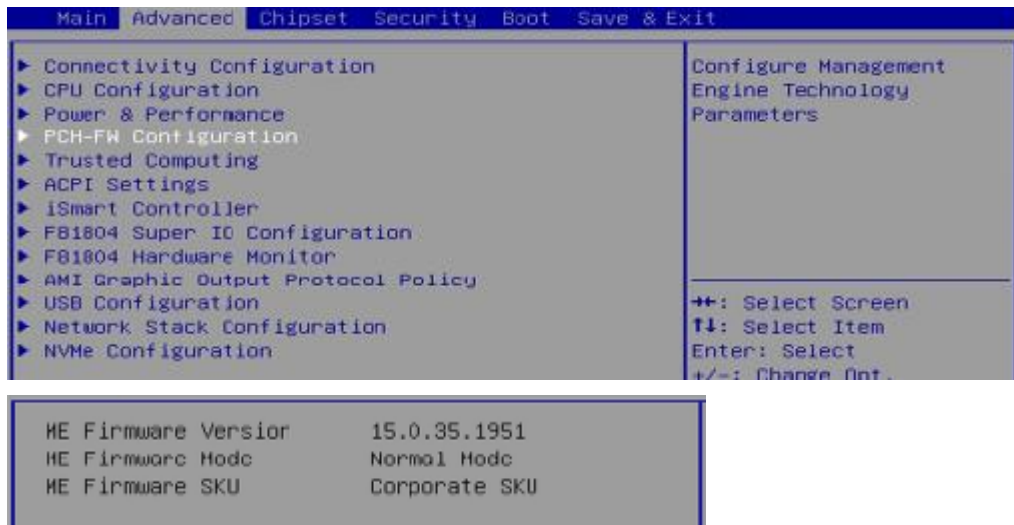

4.4.5 Trusted Computing

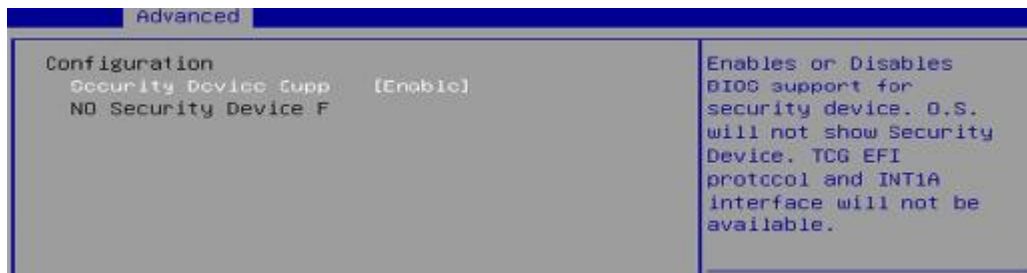

BIOS Setting	Description
Security Device Support	Option: Enable / Disable. OS will not show security device. TCG EFI protocol and INT1A interface will not be available.

4.4.6 ACPI Settings

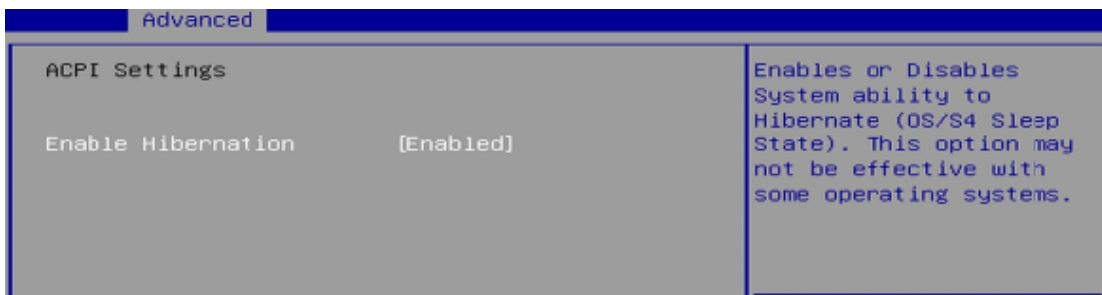

BIOS Setting	Description
Enable Hibernation	Enables or Disables System ability to Hibernate (OS/S4 Sleep State). This option may not be effective with some operating systems.

4.4.7 iSMART Controller

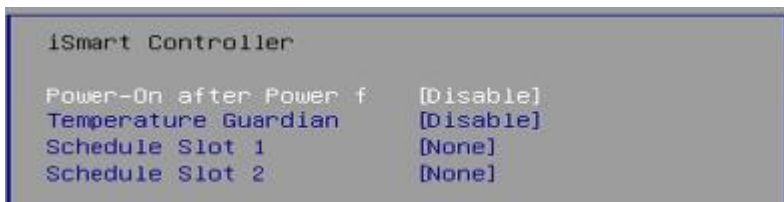
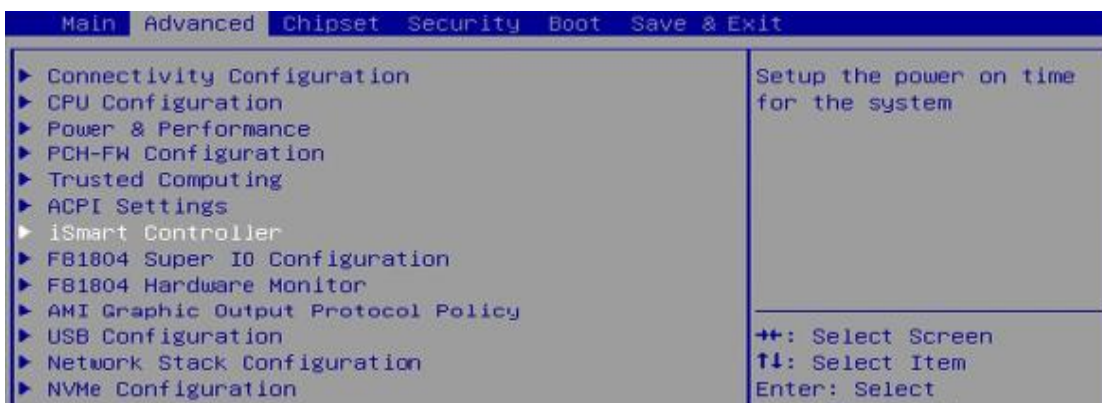

4.4.8 F81804 Super IO Configuration

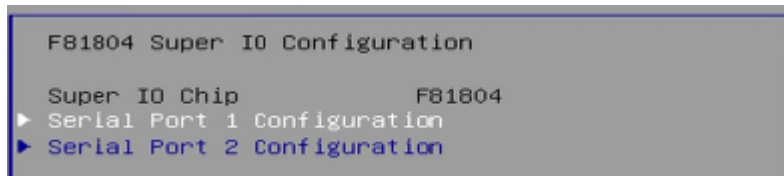
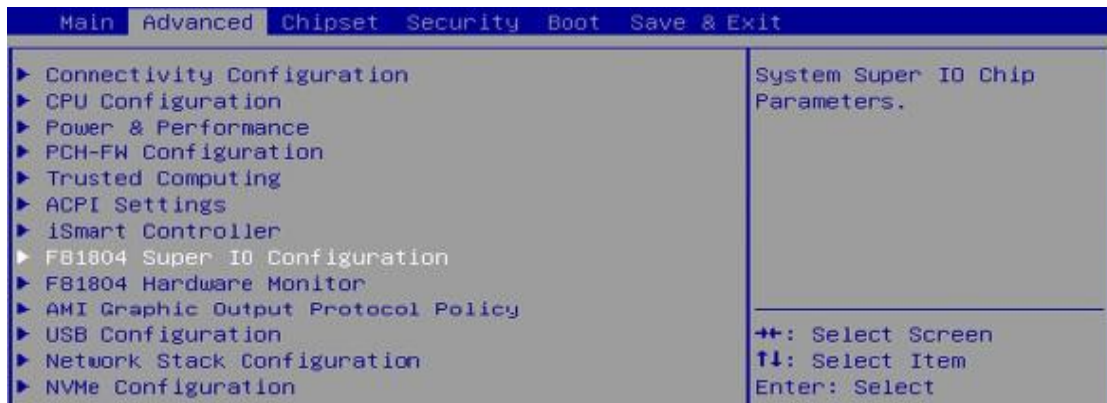

BIOS Setting	Description
Serial Port 1 Configuration	Sets parameters of Serial Port 1 (COMA).
Serial Port	Enable / Disable the serial port.
Change Settings	Select an optimal setting for the Super IO device. Options are: IO=3F8h; IRQ=4; IO=3F8h; IRQ=3,4,5,6,7,9,10,11,12; IO=2F8h; IRQ=3,4,5,6,7,9,10,11,12; IO=3E8h; IRQ=3,4,5,6,7,9,10,11,12; IO=2E8h; IRQ=3,4,5,6,7,9,10,11,12;
Serial Port Mode Select	Options are: RS232, RS485, RS422
Serial Port 2 Configuration	Sets parameters of Serial Port 2 (COMB).
Serial Port	Enable / Disable the serial port.
Change Settings	Select an optimal setting for the Super IO device. Options are: IO=3F8h; IRQ=4; IO=3F8h; IRQ=3,4,5,6,7,9,10,11,12; IO=2F8h; IRQ=3,4,5,6,7,9,10,11,12; IO=3E8h; IRQ=3,4,5,6,7,9,10,11,12; IO=2E8h; IRQ=3,4,5,6,7,9,10,11,12;

4.4.9 F81804 Hardware Monitor

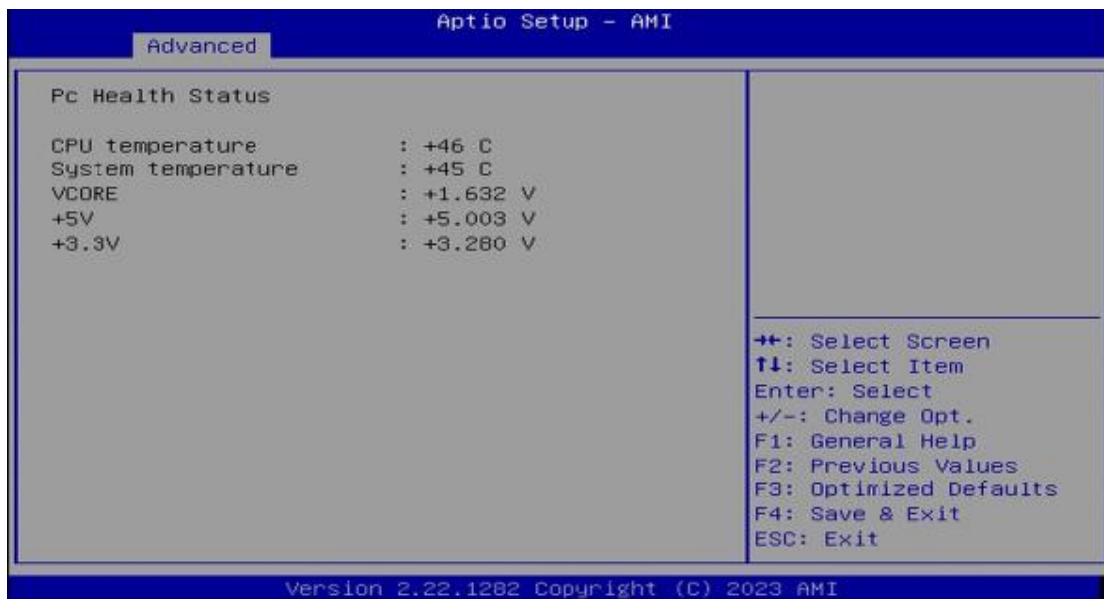

BIOS Setting	Description
Temperatures / Voltages	These fields are the parameters of the hardware monitoring function feature of the motherboard. The values are read-only values as monitored by the system and show the PC health status.

4.4.10 AMI Graphic Output Protocol Policy

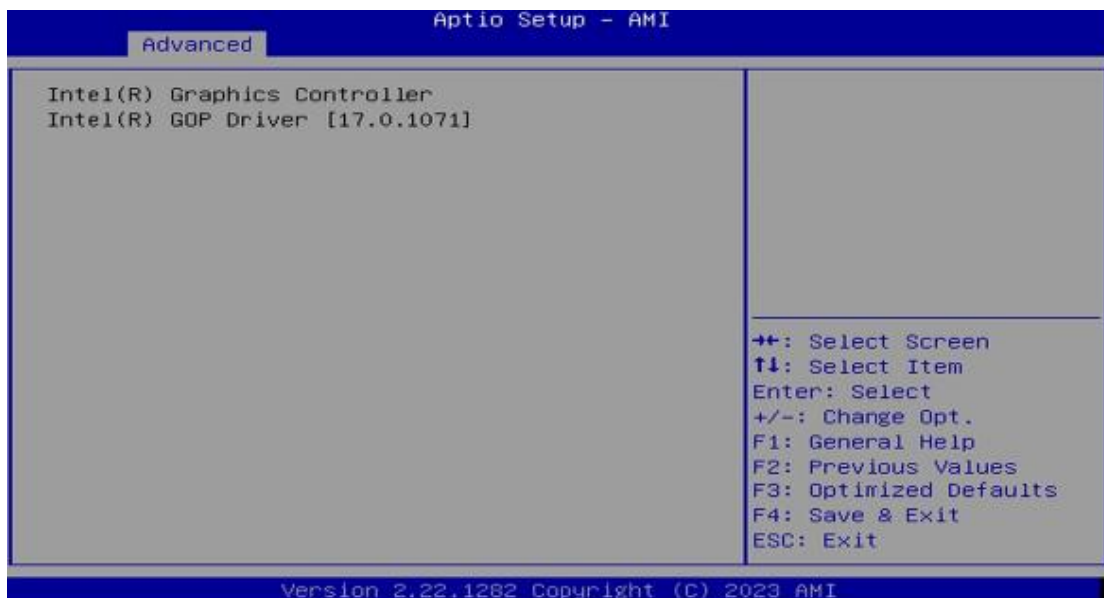

4.4.11 USB Configuration

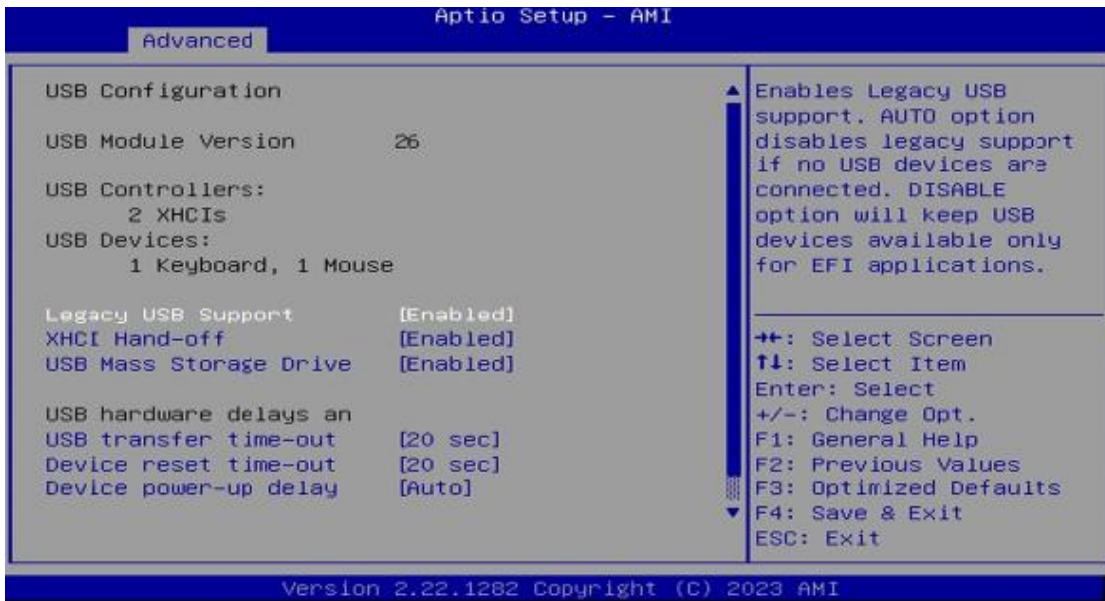

BIOS Setting	Description
Legacy USB Support	<ul style="list-style-type: none"> • Enable: Enables Legacy USB Support. • Auto: Disables legacy support if no USB devices are connected. • Disable: Keeps USB devices available only for EFI applications.
XHCI Hand-off	This is a workaround for OSES without XHCI hand-off support. The XHCI ownership change should be claimed by XHCI driver.
USB Mass Storage Driver Support	Enables / Disables the support for USB mass storage driver.
USB Transfer time-out	The time-out value for Control, Bulk, and Interrupt transfers.
Device reset time-out	Seconds of delaying execution of start unit command to USB mass storage device.
Device power-up delay	The maximum time the device will take before it properly reports itself to the Host Controller. "Auto" uses default value for a Root port it is 100ms. But for a Hub port, the delay is taken from Hub descriptor.

4.4.12 Network Stack Configuration

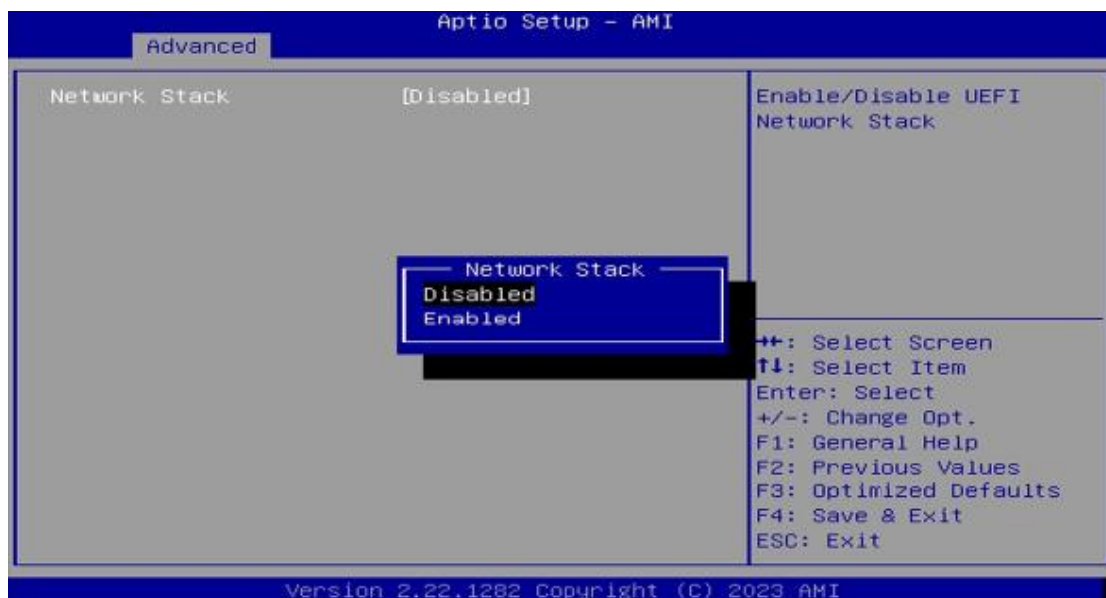

4.4.13 NVMe Configuration

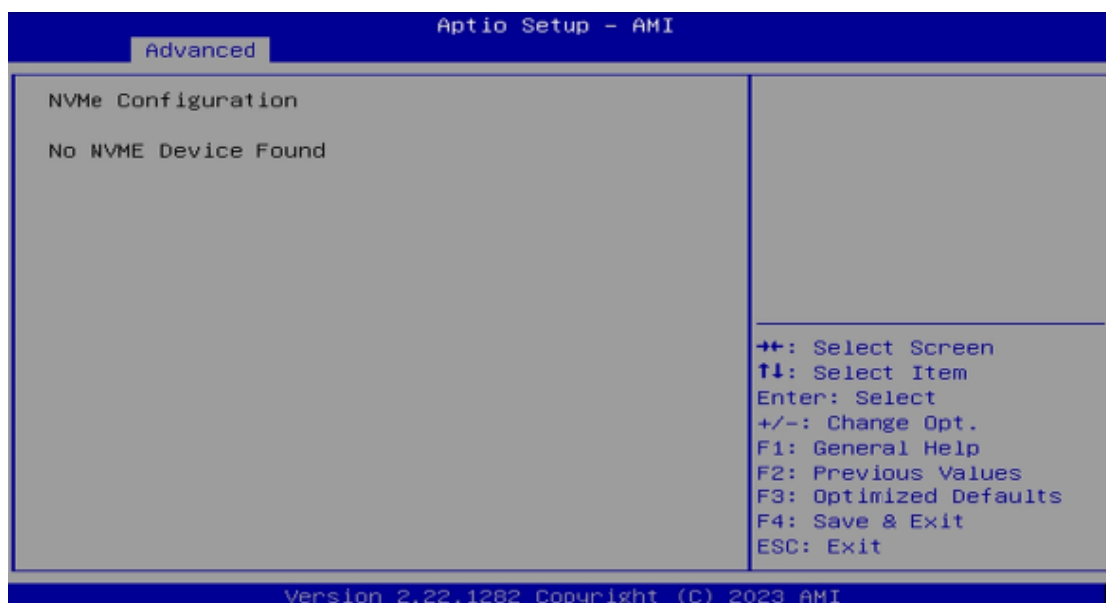

4.5 Chipset Settings

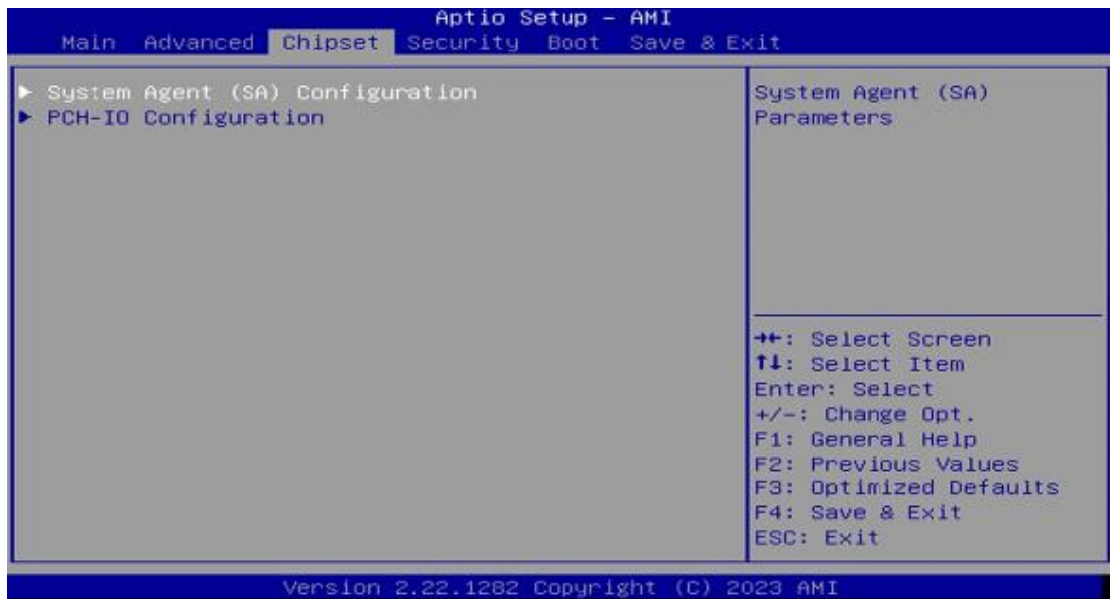

BIOS Setting	Description
System Agent (SA) Configuration	System Agent (SA) parameters
PCH-IO Configuration	PCH parameters

4.5.1 System Agent (SA) Configuration

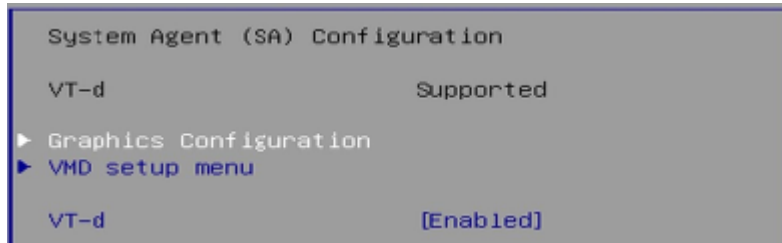

BIOS Setting	Description
Graphics Configuration	Configures the graphics settings.
VMD setup menu	VMD Configuration settings
VT-d	Checks if VT-d function on MCH is supported.

4.5.1.1. Graphics Configuration

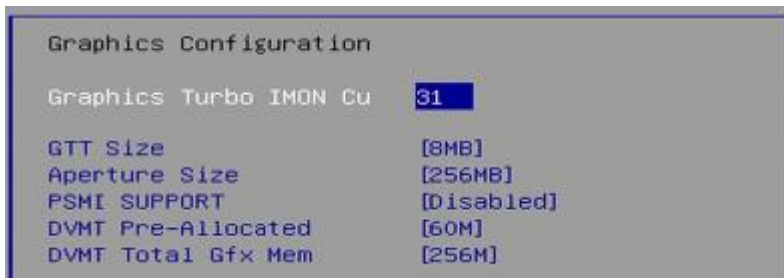

BIOS Setting	Description
Graphics Turbo IMON Cu Current Values	Supported values: 14-31
GTT Size	Sets the GTT size as 2MB, 4MB, or 8MB.
Aperture Size	Sets the aperture size as 128MB, 256MB, 512MB, 1024MB or 2048MB. Note: Above 4GB MMIO BIOS assignment is automatically enabled when selecting 2048 MB aperture. To use this feature, disable CSM support.
PSMI Support	Enable / Disable
DVMT Pre-Allocated	Select DVMT 5.0 Pre-Allocated (Fixed) Graphics Memory size used by the internal graphics device
DVMT Total Gfx mem	Select DVMT 5.0 Total Graphics Memory size used by the internal graphics device

4.5.1.2. VMD setup menu

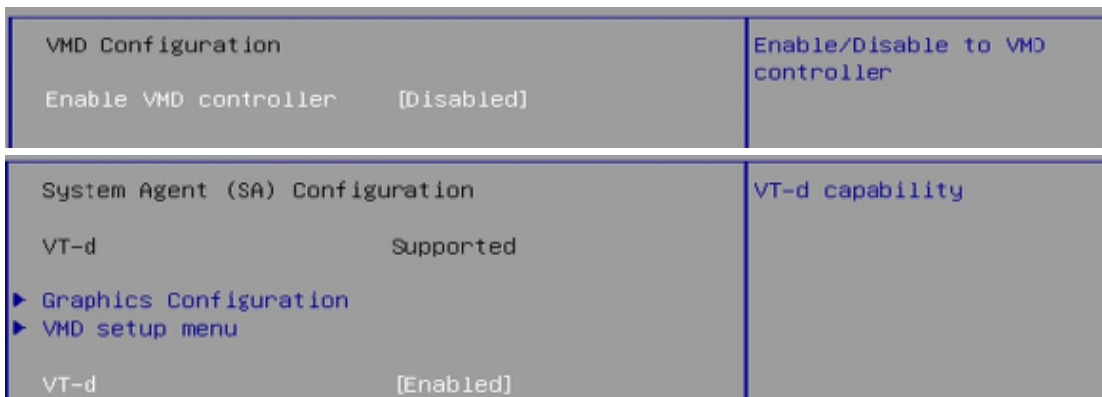

4.5.2 PCH-IO Configuration

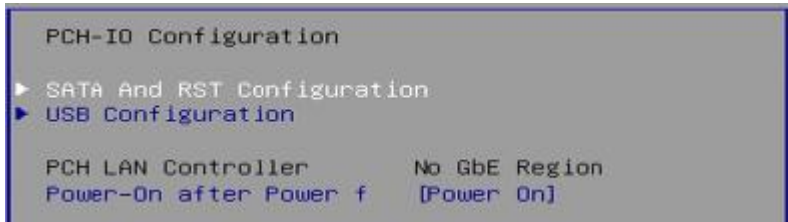

BIOS Setting	Description
SATA and RST Configuration	Configures SATA devices.
PCH LAN Controller	Enables / Disables the onboard NIC.
Power-On after Power failure	Specify what state to go to when power is reapplied after a power failure (G3 state)

4.5.2.1. SATA and RST Configuration:



4.5.2.2. USB Configuration:



4.6 Security Settings

Aptio Setup - AMI
Main Advanced Chipset **Security** Boot Save & Exit

only asked for when entering Setup.
If ONLY the User's password is set, then this is a power on password and must be entered to boot or enter Setup. In Setup the User will have Administrator rights.
The password length must be in the following range:
Minimum length 3
Maximum length 20

Administrator Password
User Password

HDD Security Configuration:
P1:TS128GHTS960T-I

HDD Security Configuration for selected drive

++: Select Screen
↑↓: Select Item
Enter: Select
+/-: Change Opt.
F1: General Help
F2: Previous Values
F3: Optimized Defaults
F4: Save & Exit
ESC: Exit

Version 2.22.1262 Copyright (C) 2023 AMI

HDD Password Description :

Allows Access to Set, Modify and Clear Hard Disk User Password and Master Password.
User Password is mandatory to Enable HDD Sec...
If Master password is installed (optional), it can also be used to unlock the HDD.
If the 'Set User Password' option is hidden, do power cycle to enable the option again.

HDD PASSWORD CONFIGURATION:

Security Supported : Yes
Security Enabled : No
Security Locked : No
Security Frozen : No
HDD User Pwd Status: NOT INSTALLED

Set HDD User Password.
*** Advisable to Power Cycle System after Setting Hard Disk Passwords ***.
Discard or Save changes option in setup does not have any impact on

++: Select Screen
↑↓: Select Item
Enter: Select
+/-: Change Opt.
F1: General Help
F2: Previous Values
F3: Optimized Defaults
F4: Save & Exit
ESC: Exit

User Password is mandatory to Enable HDD Sec...
If Master password is installed (optional), it can also be used to unlock the HDD.
If the 'Set User Password' option is hidden, do power cycle to enable the option again.

HDD PASSWORD CONFIGURATION:

Security Supported : Yes
Security Enabled : No
Security Locked : No
Security Frozen : No
HDD User Pwd Status: NOT INSTALLED
HDD Master Pwd Status: INSTALLED

Set User Password
Set Master Password

Set HDD User Password.
*** Advisable to Power Cycle System after Setting Hard Disk Passwords ***.
Discard or Save changes option in setup does not have any impact on

++: Select Screen
↑↓: Select Item
Enter: Select
+/-: Change Opt.
F1: General Help
F2: Previous Values
F3: Optimized Defaults
F4: Save & Exit
ESC: Exit

<p>If ONLY the User's password is set, then this is a power on password and must be entered to boot or enter Setup. In Setup the User will have Administrator rights. The password length must be in the following range: Minimum length 3 Maximum length 20</p> <p>Administrator Password User Password</p> <p>HDD Security Configuration: P1:TS128GMTS960T-I</p> <p>▶ Secure Boot</p>	<p>▲ Secure Boot configuration</p> <hr/> <p>++: Select Screen ↑↓: Select Item Enter: Select +/-: Change Opt. F1: General Help F2: Previous Values F3: Optimized Defaults ▼ F4: Save & Exit ESC: Exit</p>
---	--

<table border="0"> <tr> <td>System Mode</td> <td>User</td> </tr> <tr> <td>Secure Boot</td> <td>[Disabled] Not Active</td> </tr> <tr> <td>Secure Boot Mode</td> <td>[Standard]</td> </tr> <tr> <td>▶ Restore Factory Keys</td> <td></td> </tr> <tr> <td>▶ Reset To Setup Mode</td> <td></td> </tr> <tr> <td>▶ Key Management</td> <td></td> </tr> </table>	System Mode	User	Secure Boot	[Disabled] Not Active	Secure Boot Mode	[Standard]	▶ Restore Factory Keys		▶ Reset To Setup Mode		▶ Key Management		<p>Secure Boot feature is Active if Secure Boot is Enabled, Platform Key(PK) is enrolled and the System is in User mode. The mode change requires platform reset</p>
System Mode	User												
Secure Boot	[Disabled] Not Active												
Secure Boot Mode	[Standard]												
▶ Restore Factory Keys													
▶ Reset To Setup Mode													
▶ Key Management													

<table border="0"> <tr> <td>System Mode</td> <td>User</td> </tr> <tr> <td>Secure Boot</td> <td>[Disabled] Not Active</td> </tr> <tr> <td>Secure Boot Mode</td> <td>[Standard]</td> </tr> <tr> <td>▶ Restore Factory Keys</td> <td></td> </tr> <tr> <td>▶ Reset To Setup Mode</td> <td></td> </tr> <tr> <td>▶ Key Management</td> <td></td> </tr> </table>	System Mode	User	Secure Boot	[Disabled] Not Active	Secure Boot Mode	[Standard]	▶ Restore Factory Keys		▶ Reset To Setup Mode		▶ Key Management		<p>Secure Boot mode options: Standard or Custom. In Custom mode, Secure Boot Policy variables can be configured by a physically present user without full authentication</p>
System Mode	User												
Secure Boot	[Disabled] Not Active												
Secure Boot Mode	[Standard]												
▶ Restore Factory Keys													
▶ Reset To Setup Mode													
▶ Key Management													

BIOS Setting	Description
Administrator Password	Sets an administrator password for the setup utility.
User Password	Sets a user password.
Secure Boot	Secure Boot feature is Active if Secure Boot is enabled. Platform Key (PK) is enrolled and the system is in User mode. The mode change requires platform reset.
Secure Boot Mode	Secure Boot mode options: Standard or Custom. In Custom mode, Secure Boot Policy variables can be configured by a physically present user without full authentication.
Restore Factory Keys	Forces system to user mode. Install factory default Secure Boot key databases.
Key Management	Enables expert users to modify Secure Boot Policy variables without full authentication.

4.7 Boot Settings

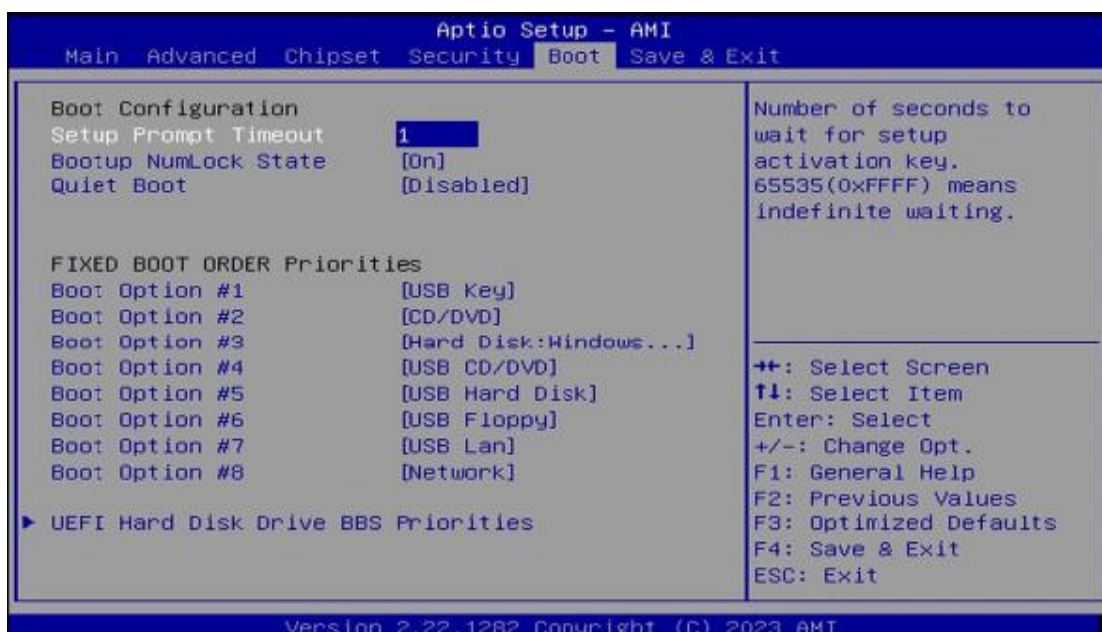

BIOS Setting	Description
Setup Prompt Timeout	Number of seconds to wait for setup activation key. 65535(0xFFFF) means indefinite waiting.
Bootup NumLock State	Selects the keyboard NumLock state.
Quiet Boot	Enables / Disables Quiet Boot option.
Boot mode select	Selects a Boot mode, Legacy / UEFI.
Boot Option Priorities	Sets the system boot order.
UEFI Hard Disk Drive BBS Priorities	Specifies the Boot Device Priority sequence from available UEFI Hard Disk Drives.

4.8 Save & Exit Settings

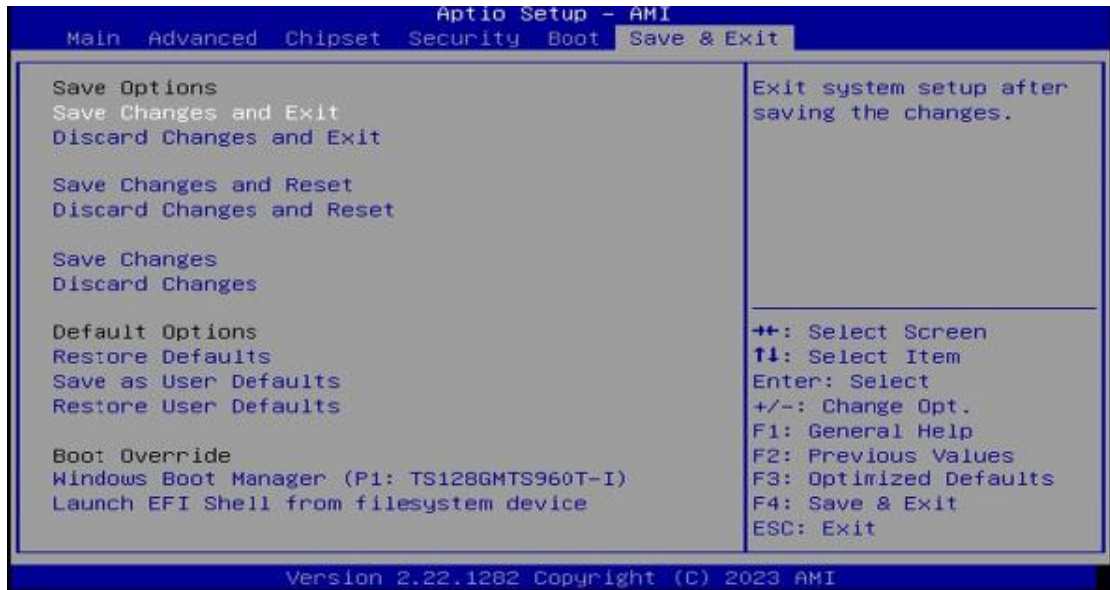

BIOS Setting	Description
Save Changes and Exit	Exits system setup after saving the changes.
Discard Changes and Exit	Exits system setup without saving any changes.
Save Changes and Reset	Resets the system after saving the changes.
Discard Changes and Reset	Resets system setup without saving any changes.
Save Changes	Saves changes done so far to any of the setup options.
Discard Changes	Discards changes done so far to any of the setup options.
Restore Defaults	Restores / Loads defaults values for all the setup options.
Save as User Defaults	Saves the changes done so far as User Defaults.
Restore User Defaults	Restores the user defaults to all the setup options.
Launch EFI Shell from filesystem device	Attempts to launch EFI Shell application (Shell.efi) from one of the available filesystem devices.

Appendix

This section provides the mapping addresses of peripheral devices and the sample code of watchdog timer configuration.

- I/O Port Address Map
- Interrupt Request Lines (IRQ)
- Watchdog Timer

A. I/O Port Address Map

Each peripheral device in the system is assigned a set of I/O port addresses which also becomes the identity of the device. The following table lists the I/O port addresses used.

Address	Device Description
0x00000A00-0x00000A0F	Motherboard resources
0x00000A20-0x00000A2F	Motherboard resources
0x00000A10-0x00000A1F	Motherboard resources
0x0000002E-0x0000002F	Motherboard resources
0x0000004E-0x0000004F	Motherboard resources
0x00000061-0x00000061	Motherboard resources
0x00000063-0x00000063	Motherboard resources
0x00000065-0x00000065	Motherboard resources
0x00000067-0x00000067	Motherboard resources
0x00000070-0x00000070	Motherboard resources
0x00000080-0x00000080	Motherboard resources
0x00000092-0x00000092	Motherboard resources
0x000000B2-0x000000B3	Motherboard resources
0x00000068-0x00000069F	Motherboard resources
0x0000164E-0x0000164F	Motherboard resources
0x00000020-0x00000021	Programmable interrupt controller
0x00000024-0x00000025	Programmable interrupt controller
0x00000028-0x00000029	Programmable interrupt controller
0x0000002C-0x0000002D	Programmable interrupt controller
0x00000030-0x00000031	Programmable interrupt controller
0x00000034-0x00000035	Programmable interrupt controller
0x00000038-0x00000039	Programmable interrupt controller
0x0000003C-0x0000003D	Programmable interrupt controller
0x000000A0-0x000000A1	Programmable interrupt controller
0x000000A4-0x000000A5	Programmable interrupt controller
0x000000A8-0x000000A9	Programmable interrupt controller
0x000000AC-0x000000AD	Programmable interrupt controller

0x000000B0-0x000000B1	Programmable interrupt controller
0x000000B4-0x000000B5	Programmable interrupt controller
0x000000B8-0x000000B9	Programmable interrupt controller
0x000000BC-0x000000BD	Programmable interrupt controller
0x000004D0-0x000004D1	Programmable interrupt controller
0x00001854-0x00001857	Motherboard resources
0x00004090-0x00004097	Standard SATA AHCI Controller
0x00004080-0x00004083	Standard SATA AHCI Controller
0x00004060-0x0000407F	Standard SATA AHCI Controller
0x000003F8-0x000003FF	Communications Port (COM1)
0x000002F8-0x000002FF	Communications Port (COM2)
0x00001800-0x000018FE	Motherboard resources
0x00004000-0x0000403F	Intel(R) UHD Graphics
0x00000000-0x00000CF7	PCI Express Root Complex
0x00000D00-0x0000FFFF	PCI Express Root Complex
0x00000040-0x00000043	System timer
0x00000050-0x00000053	System timer
0x00003000-0x00003FFF	Intel(R) PCI Express Root Port #7 - A0BE
0x00002000-0x000020FE	Motherboard resources
0x00000060-0x00000060	Standard PS/2 Keyboard
0x00000064-0x00000064	Standard PS/2 Keyboard
0x0000EFA0-0x0000EFBF	Intel(R) SMBus - A0A3

B. Interrupt Request Lines (IRQ)

Peripheral devices use interrupt request lines to notify CPU for the service required. The following table shows the IRQ used by the devices on board.

Level	Function
IRQ 4294967288	Intel(R) Ethernet Connection (13) I219-V
IRQ 4294967289	Intel(R) USB 3.10 eXtensible Host Controller - 1.20 (Microsoft)
IRQ 4294967291	Standard SATA AHCI Controller
IRQ 4294967290	Intel(R) USB 3.10 eXtensible Host Controller - 1.20 (Microsoft)
IRQ 4	Communications Port (COM1)
IRQ 3	Communications Port (COM2)
IRQ 4294967284	Intel(R) UHD Graphics
IRQ 54 ~ IRQ 204	Microsoft ACPI-Compliant System
IRQ 256 ~ IRQ 511	Microsoft ACPI-Compliant System
IRQ 4294967294	PCI Express Root Port
IRQ 14	Intel(R) GPIO Controller - 34C5
IRQ 0	System timer
IRQ 28	Trusted Platform Module 2.0
IRQ 4294967292	Intel(R) PCI Express Root Port #7 - A0BE
IRQ 4294967282	Intel(R) Management Engine Interface
IRQ 1	Standard PS/2 Keyboard
IRQ 12	Microsoft PS/2 Mouse
IRQ 4294967287	Intel(R) I211 Gigabit Network Connection
IRQ 4294967286	Intel(R) I211 Gigabit Network Connection
IRQ 4294967285	Intel(R) I211 Gigabit Network Connection
IRQ 4294967283	Intel(R) I211 Gigabit Network Connection
IRQ 4294967293	PCI Express Root Port
IRQ 16	High Definition Audio Controller
IRQ 17	USB Synopsys Controller

C. Watchdog Timer

The Watchdog Timer (WDT) is used to generate a variety of output signals after a user programmable count. The WDT is suitable for the use in the prevention of system lock-up, such as when software becomes trapped in a deadlock. Under these sorts of circumstances, the timer will count to zero and the selected outputs will be driven. Under normal circumstance, you will need to restart the WDT at regular intervals before the timer counts to zero.

Sample Code

```
//-----
//
// THIS CODE AND INFORMATION IS PROVIDED "AS IS" WITHOUT WARRANTY OF ANY
// KIND, EITHER EXPRESSED OR IMPLIED, INCLUDING BUT NOT LIMITED TO THE
// IMPLIED WARRANTIES OF MERCHANTABILITY AND/OR FITNESS FOR A
// PARTICULAR PURPOSE.
//
//-----
#include <dos.h>
#include <conio.h>
#include <stdio.h>
#include <stdlib.h>
#include " F81804.H"
//-----
int main (int argc, char *argv[]);
void EnableWDT(int);
void DisableWDT(void);
//-----
int main (int argc, char *argv[])
{
    unsigned char bBuf;
    unsigned char bTime;
    char **endptr;

    char SIO;

    printf("Fintek 81866 watch dog program\n");
    SIO = Init_ F81804();
    if (SIO == 0)
    {
        printf("Can not detect Fintek 81866, program abort.\n");
        return(1);
    }
    //if (SIO == 0)

    if (argc != 2)
    {
        printf(" Parameter incorrect!!\n");
        return (1);
    }

    bTime = strtol (argv[1], endptr, 10);
    printf("System will reset after %d seconds\n", bTime);
```

```

        if (bTime)
        { EnableWDT(bTime); }
        else
        { DisableWDT(); }
        return 0;
    }
//-----
void EnableWDT(int interval)
{
    unsigned char bBuf;

    bBuf = Get_ F81804_Reg(0x2B);
    bBuf &= (~0x20);
    Set_ F81804_Reg(0x2B,  bBuf); //Enable WDTO

    Set_ F81804_LD(0x07);          //switch to logic device 7
    Set_ F81804_Reg(0x30,  0x01); //enable timer

    bBuf = Get_ F81804_Reg(0xF5);
    bBuf &= (~0x0F);
    bBuf |= 0x52;
    Set_ F81804_Reg(0xF5,  bBuf); //count mode is second

    Set_ F81804_Reg(0xF6,  interval); //set timer

    bBuf = Get_ F81804_Reg(0xFA);
    bBuf |= 0x01;
    Set_ F81804_Reg(0xFA,  bBuf); //enable WDTO output

    bBuf = Get_ F81804_Reg(0xF5);
    bBuf |= 0x20;
    Set_ F81804_Reg(0xF5,  bBuf); //start counting
}
//-----
void DisableWDT(void)
{
    unsigned char bBuf;

    Set_ F81804_LD(0x07);          //switch to logic device 7

    bBuf = Get_ F81804_Reg(0xFA);
    bBuf &= ~0x01;
    Set_ F81804_Reg(0xFA,  bBuf); //disable WDTO output

    bBuf = Get_ F81804_Reg(0xF5);
    bBuf &= ~0x20;
    bBuf |= 0x40;
    Set_ F81804_Reg(0xF5,  bBuf); //disable WDT
}
//-----

```

```

//-----
//
// THIS CODE AND INFORMATION IS PROVIDED "AS IS" WITHOUT WARRANTY OF ANY
// KIND, EITHER EXPRESSED OR IMPLIED, INCLUDING BUT NOT LIMITED TO THE
// IMPLIED WARRANTIES OF MERCHANTABILITY AND/OR FITNESS FOR A
// PARTICULAR
// PURPOSE.
//
//-----
#include " F81804.H"
#include <dos.h>
//-----
unsigned int  F81804_BASE;
void Unlock_ F81804 (void);
void Lock_ F81804 (void);
//-----
unsigned int Init_ F81804(void)
{
    unsigned int result;
    unsigned char ucDid;

    F81804_BASE = 0x4E;
    result = F81804_BASE;

    ucDid = Get_ F81804_Reg(0x20);
    if (ucDid == 0x07) //Fintek 81866
    { goto Init_Finish; }

    F81804_BASE = 0x2E;
    result = F81804_BASE;

    ucDid = Get_ F81804_Reg(0x20);
    if (ucDid == 0x07) //Fintek 81866
    { goto Init_Finish; }

    F81804_BASE = 0x00;
    result = F81804_BASE;

Init_Finish:
    return (result);
}
//-----
void Unlock_ F81804 (void)
{
    outportb( F81804_INDEX_PORT, F81804_UNLOCK);
    outportb( F81804_INDEX_PORT, F81804_UNLOCK);
}
//-----
void Lock_ F81804 (void)
{
    outportb( F81804_INDEX_PORT, F81804_LOCK);
}
//-----

```

iBASE

```
void Set_ F81804_LD( unsigned char LD)
{
    Unlock_ F81804();
    outportb( F81804_INDEX_PORT, F81804_REG_LD);
    outportb( F81804_DATA_PORT, LD);
    Lock_ F81804();
}
//-----
void Set_ F81804_Reg( unsigned char REG, unsigned char DATA)
{
    Unlock_ F81804();
    outportb( F81804_INDEX_PORT, REG);
    outportb( F81804_DATA_PORT, DATA);
    Lock_ F81804();
}
//-----
unsigned char Get_ F81804_Reg(unsigned char REG)
{
    unsigned char Result;
    Unlock_ F81804();
    outportb( F81804_INDEX_PORT, REG);
    Result = inportb( F81804_DATA_PORT);
    Lock_ F81804();
    return Result;
}
//-----
```

```
//-----  
//  
// THIS CODE AND INFORMATION IS PROVIDED "AS IS" WITHOUT WARRANTY OF ANY  
// KIND, EITHER EXPRESSED OR IMPLIED, INCLUDING BUT NOT LIMITED TO THE  
// IMPLIED WARRANTIES OF MERCHANTABILITY AND/OR FITNESS FOR A  
// PARTICULAR  
// PURPOSE.  
//  
//-----  
#ifndef F81804_H  
#define F81804_H 1  
//-----  
#define F81804_INDEX_PORT ( F81804_BASE)  
#define F81804_DATA_PORT ( F81804_BASE+1)  
//-----  
#define F81804_REG_LD 0x07  
//-----  
#define F81804_UNLOCK 0x87  
#define F81804_LOCK0xAA  
//-----  
unsigned int Init_ F81804(void);  
void Set_ F81804_LD( unsigned char);  
void Set_ F81804_Reg( unsigned char,  
unsigned char); unsigned char  
Get_ F81804_Reg( unsigned char);  
//-----  
#endif // F81804_H
```