

**SW-101-N**  
**Outdoor Waterproof**  
**Digital Signage Player**

**User's Manual**

Version 1.0  
(August 2020)



## **Copyright**

© 2020 IBASE Technology, Inc. All rights reserved.

No part of this publication may be reproduced, copied, stored in a retrieval system, translated into any language or transmitted in any form or by any means, electronic, mechanical, photocopying, or otherwise, without the prior written consent of IBASE Technology, Inc. (hereinafter referred to as "IBASE").

## **Disclaimer**

IBASE reserves the right to make changes and improvements to the products described in this document without prior notice. Every effort has been made to ensure the information in the document is correct; however, IBASE does not guarantee this document is error-free. IBASE assumes no liability for incidental or consequential damages arising from misapplication or inability to use the product or the information contained herein, nor for any infringements of rights of third parties, which may result from its use.

## **Trademarks**

All the trademarks, registrations and brands mentioned herein are used for identification purposes only and may be trademarks and/or registered trademarks of their respective owners.

## Compliance

### CE

This product has passed CE Class B tests for environmental specifications and limits. This product is in accordance with the directives of the European Union (EU). In a domestic environment, this product may cause radio interference in which case users may be required to take adequate measures.

### FCC

This product has been tested and found to comply with the limits for a Class B device, pursuant to Part 15 of the FCC Rules. These limits are designed to provide reasonable protection against harmful interference in a residential installation. This equipment generates, uses and can radiate radio frequency energy and, if not installed and used in accordance with manufacturer's instructions, may cause harmful interference to radio communications.

### WEEE



This product must not be disposed of as normal household waste, in accordance with the EU directive of for waste electrical and electronic equipment (WEEE - 2012/19/EU). Instead, it should be disposed of by returning it to a municipal recycling collection point. Check local regulations for disposal of electronic products.

### Green IBASE



This product is compliant with the current RoHS restrictions and prohibits use of the following substances in concentrations exceeding 0.1% by weight (1000 ppm) except for cadmium, limited to 0.01% by weight (100 ppm).

- Lead (Pb)
- Mercury (Hg)
- Cadmium (Cd)
- Hexavalent chromium (Cr6+)
- Polybrominated biphenyls (PBB)
- Polybrominated diphenyl ether (PBDE)

## Important Safety Information

Carefully read the precautions before using the device.

### Environmental conditions:

- Slots and openings on the chassis are for ventilation. Make sure you leave plenty of space around the device for ventilation. Never allow objects of any kind to enter any openings in the system.
- Use this product in environments with ambient temperatures between -40°C and 75°C.
- Do not leave this device in an environment where the storage temperature may be below -20°C or above 80°C. This could damage the device. The device must be used in a controlled environment.

### Care for your iBASE products:

- Before cleaning the device, turn it off and unplug all external power sources.
- Use neutral cleaning agents or diluted alcohol to clean the device with a cloth; then wipe it with a dry cloth.
- Vacuum the dust with a computer vacuum cleaner to prevent the air vent or slots from being clogged.



## WARNING

### Attention during use:

- Do not use this product near water.
- Do not spill water or any other liquids on your device.
- Do not place heavy objects on the top of the device.
- Operate the device from the type of power source indicated on the marking label.
- Do not allow anything to rest on the power cord.
- If an extension cord is used, make sure that the total ampere rating of the product plugged into the extension cord does not exceed the extension cord ampere rating.

### Avoid Disassembly

Do not disassemble, repair or make any modification to the device. Doing so could generate hazards and cause damage to the device, even bodily injury or property damage, and will void any warranty.



## CAUTION

There is danger of explosion if internal lithium-ion battery is replaced by an incorrect type. Replace only with the same or equivalent type recommended by the manufacturer.

## Warranty Policy

- **IBASE standard products:**

24-month (2-year) warranty from the date of shipment. If the date of shipment cannot be ascertained, the product serial numbers can be used to determine the approximate shipping date.

- **3<sup>rd</sup>-party parts:**

12-month (1-year) warranty from delivery for the 3<sup>rd</sup>-party parts that are not manufactured by IBASE, such as CPU, CPU cooler, memory, storage devices, power adapter, panel and touchscreen.

\* PRODUCTS, HOWEVER, THAT FAIL DUE TO MISUSE, ACCIDENT, IMPROPER INSTALLATION OR UNAUTHORIZED REPAIR SHALL BE TREATED AS OUT OF WARRANTY AND CUSTOMERS SHALL BE BILLED FOR REPAIR AND SHIPPING CHARGES.

## Technical Support & Services

1. Visit the IBASE website at [www.ibase.com.tw](http://www.ibase.com.tw) to find the latest information about the product.
2. If you need any further assistance from your distributor or sales representative, prepare the following information of your product and elaborate upon the problem.
  - Product model name
  - Product serial number
  - Detailed description of the problem
  - The error messages in text or in screenshots if there is any
  - The arrangement of the peripherals
  - Software in use (such as OS and application software, including the version numbers)
3. If repair service is required, you can download the RMA form at <http://www.ibase.com.tw/english/Supports/RMAService/>. Fill out the form and contact your distributor or sales representative.

# Table of Contents

---

|                  |  |           |
|------------------|--|-----------|
| <b>Chapter 1</b> | <b>General Information .....</b>                                 | <b>1</b>  |
| 1.1              | Introduction .....   | 2         |
| 1.2              | Features.....  | 2         |
| 1.3              | Packing List .....   | 4         |
| 1.4              | Optional Accessories .....                                       | 4         |
| 1.5              | Specifications.....  | 7         |
| 1.6              | Product View.....  | 9         |
| 1.7              | Dimensions .....   | 10        |
| <b>Chapter 2</b> | <b>Hardware Installation &amp; Motherboard Information .....</b> | <b>11</b> |
| 2.1              | Installation / Replacement .....                                 | 12        |
| 2.1.1            | Memory .....   | 12        |
| 2.1.2            | Mini-PCIe Cards .....  | 13        |
| 2.1.3            | WiFi / 3G / 4G Antenna Installation.....                         | 13        |
| 2.1.4            | Wall Mount Installation.....                                     | 14        |
| 2.2              | Pinout for DC Power Input Connector .....                        | 15        |
| 2.3              | Pinout for Digital I/O Connector.....                            | 16        |
| 2.4              | Pinout for COM1 RS-232 Port.....                                 | 17        |
| 2.5              | Pinout for LAN Port (M12).....                                   | 18        |
| 2.6              | Pinout for USB Ports (M12).....                                  | 19        |
| 2.7              | Setting the Jumpers .....  | 20        |
| 2.8              | Jumper & Connector Locations on Motherboard .....                | 22        |
| 2.9              | Jumpers Quick Reference.....                                     | 23        |
| 2.9.1            | Clear CMOS Data (JP4).....                                       | 23        |
| 2.9.2            | Clear ME Register (JP5) .....                                    | 24        |
| 2.10             | Connectors Quick Reference .....                                 | 25        |
| 2.8.1            | Board Input Power Connector (CN4) .....                          | 25        |
| 2.8.2            | 5V Power Connector (J1) .....                                    | 26        |
| 2.8.3            | RTC Battery Connector (J3) .....                                 | 26        |
| 2.8.4            | Reset Connector (J8).....  | 26        |
| 2.8.5            | Speaker Connector (J9, J10).....                                 | 27        |
| 2.8.6            | COM RS-232 Connector (J11, J12).....                             | 27        |
| 2.8.7            | LAN Connector (J13) .....  | 28        |
| 2.8.8            | HDMI Connector (J14, J15) .....                                  | 28        |
| 2.8.9            | Digital I/O Connector (J16) .....                                | 29        |
| 2.8.10           | System Fan Power Connector (SYS_FAN1).....                       | 29        |

|                  |  |           |
|------------------|--|-----------|
| <b>Chapter 3</b> | <b>Driver Installation .....</b>                           | <b>30</b> |
| 3.1              | Introduction .....   | 31        |
| 3.2              | Intel® Chipset Software Installation Utility .....         | 31        |
| 3.3              | Graphics Driver Installation .....                         | 33        |
| 3.4              | HD Audio Driver Installation .....                         | 34        |
| 3.5              | LAN Driver Installation .....                              | 35        |
| 3.6              | Intel® Trusted Execution Engine Drivers Installation ..... | 36        |
| <b>Chapter 4</b> | <b>BIOS Setup .....</b>                                    | <b>37</b> |
| 4.1              | Introduction .....   | 38        |
| 4.2              | BIOS Setup .....   | 38        |
| 4.3              | Main Settings .....  | 39        |
| 4.4              | Advanced Settings .....                                    | 40        |
| 4.4.1            | ACPI Settings .....  | 41        |
| 4.4.2            | iSmart Controller .....                                    | 42        |
| 4.4.3            | Super IO Configuration .....                               | 43        |
| 4.4.4            | HW Monitor .....   | 46        |
| 4.4.5            | CPU Configuration .....                                    | 47        |
| 4.4.6            | PPM Configuration .....                                    | 47        |
| 4.4.7            | IDE Configuration .....                                    | 48        |
| 4.4.8            | USB Configuration .....                                    | 49        |
| 4.5              | Chipset Settings .....                                     | 50        |
| 4.6              | Security Settings .....                                    | 51        |
| 4.7              | Boot Settings .....  | 52        |
| 4.8              | Save & Exit Settings .....                                 | 53        |
| <b>Appendix</b>  | <b>.....</b>   | <b>54</b> |
| A.               | I/O Port Address Map .....                                 | 55        |
| B.               | Interrupt Request Lines (IRQ) .....                        | 57        |
| C.               | Watchdog Timer Configuration .....                         | 58        |



# Chapter 1

## General Information

The information provided in this chapter includes:

- Product Features
- Packing List
- Optional Accessories
- Specifications
- Product View
- Dimensions

## 1.1 Introduction

The SW-101-N is a waterproof digital signage player designed for both indoor and harsh outdoor environments. This rugged fanless signage player is integrated with a 1.91GHz Intel® Atom™ Processor E3845 Quad-Core Processor and Intel® HD graphics (Gen 7-LP) 4EU.

The SW-101-N is built to withstand dust, water and extreme temperatures. It meets IP68 standards, allowing it to handle submersion in water for up to 30 minutes at a depth of 1.5 meters. The black-color waterproof enclosure utilizes a C3 HDMI connector and M12 I/O interface connectors for two USB 2.0, one Gigabit LAN, one RS232, DC power input, and digital I/O. Two antenna N jack type connectors have waterproof design as well. Aside from being fanless, the unit has a wide operating temperature range of -40°C ~ 75°C.

The SW-101-N supports IBASE unique iControl and Observer technologies for intelligent control and remote monitoring functions that feature auto power on/off scheduling, power resume, system temperature/voltage remote monitoring, and low temperature boot protection. The standard model has 4GB of DDR3L-1333 system memory, 64GB mSATA storage, and 12V DC-in support. Additional features include a watchdog timer, wall mount and Mini PCIe expansion for optional wireless modules.



## 1.2 Features

- iControl intelligent energy-saving & Observer remote monitoring technologies
- Waterproof, rugged, and fanless design with IP48 rating
- Intel® Atom™ E3845 Quad Core CPU
- 1 x DDR3L SO-DIMM 1333 MHz, expandable up to 8 GB, non-ECC
- Display output via M12 HDMI
- 2 x USB 2.0, 1 x RS-232, 1 x Digital I/O (all M12 connectors)
- 1 x Mini-PCIe slot for Wi-Fi or 3G/4G LTE options
- 1 x mSATA for storage
- -40°C ~ 75°C wide-range operating temperature



### 1.3 Packing List

Your product package should include the items listed below. If any of the items below is missing, contact the distributor or the dealer from whom you purchased the product.

- SW-101-N Digital Signage Player

### 1.4 Optional Accessories

IBASE provides the following optional accessories:

- HDMI cable (with C3 rugged connector)

P/N: C501HDMI140A12000P

One end of the cable is an M12 connector and the other end is an HDMI connector. Length is 180cm.

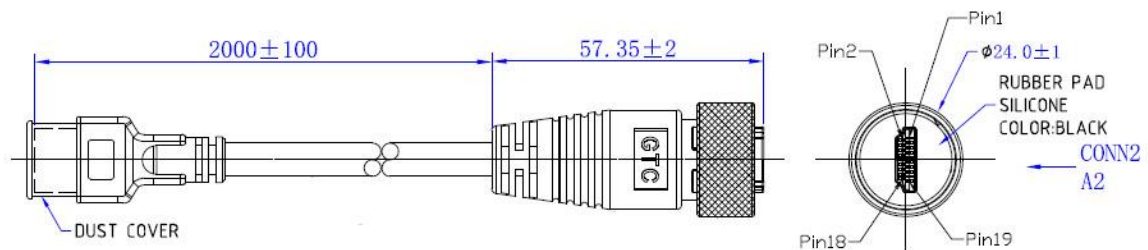

- Power cable (M12 female to 3-pin terminal connector)

P/N: C501PW49800182000P

One end of the cable is an M12 connector and the other end is bare wire which is to be installed by the customer. Cable length is 180cm.

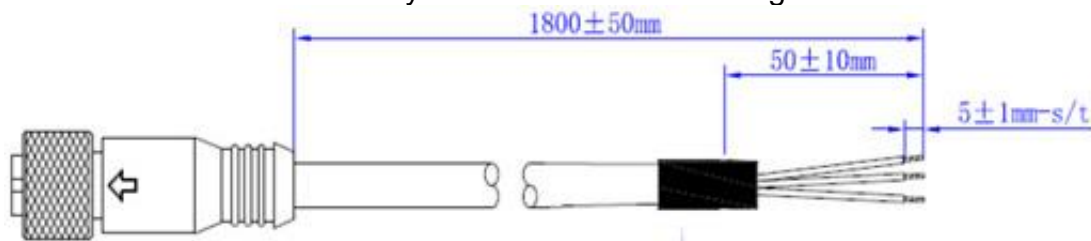

- PW518 Power Supply Cable

One end of the cable is an M12 connector and the other end a 4-pin Dinkle terminal block female plug (2EHDP-03P). Cable length is 180cm.  
P/N: Y05PW5180A120000P

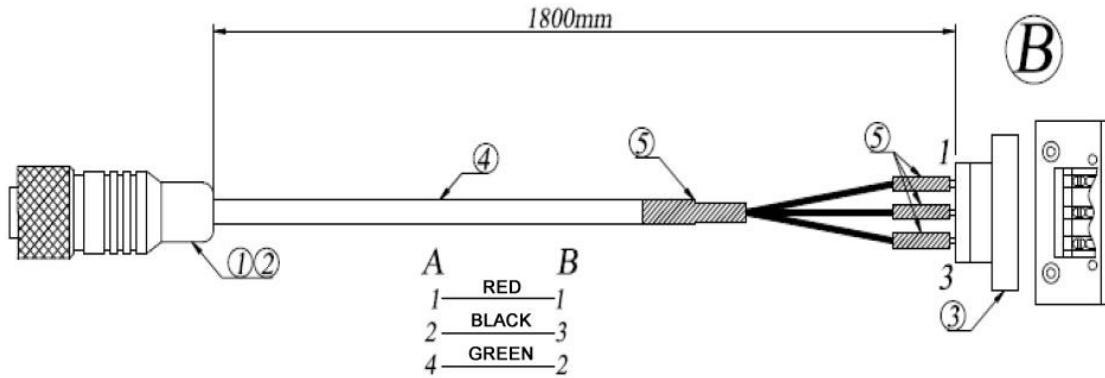

- LAN cable (M12 female to RJ45)

P/N: C501LAN6000A12000P

One end of the cable is an M12 connector and the other end is an RJ45 connector. Length is 180cm.

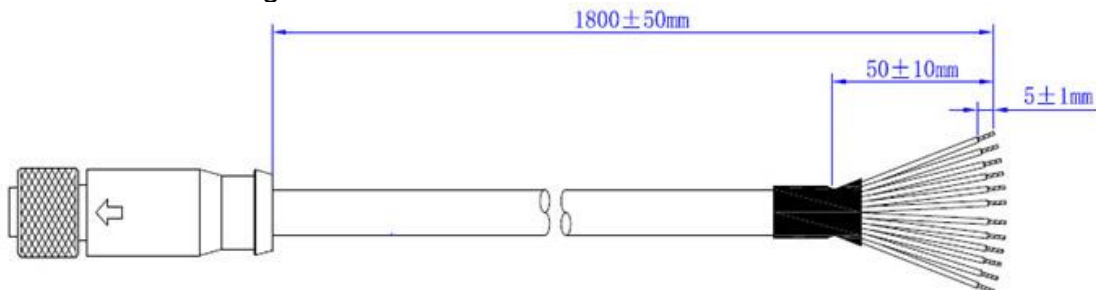

- USB 2.0 cable (M12 female to USB 2.0)

P/N: C501USB1620A12000P

One end of the cable is an M12 connector and the other end is a USB connector. Length is 180cm.

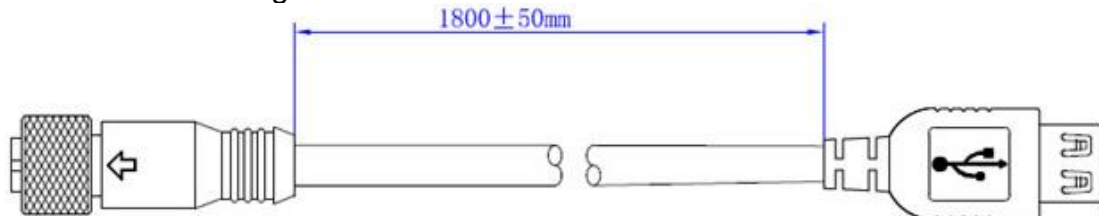

- Digital I/O cable (M12 female to open wire)

P/N : C501EXT6860A12000P

One end of the cable is an M12 connector and the other end is bare wire. Length is 180cm.

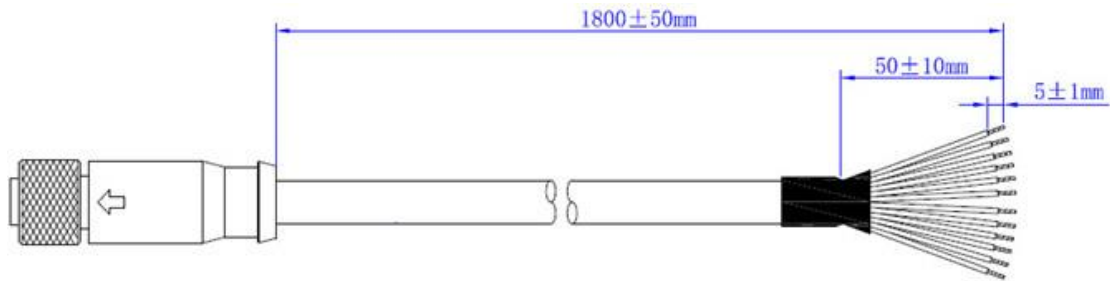

- Serial cable (M12 female to D-Sub9)

P/N: C501EXT6850A12000P

One end of the cable is an M12 connector and the other end is a DB9 connector. Length is 180cm.

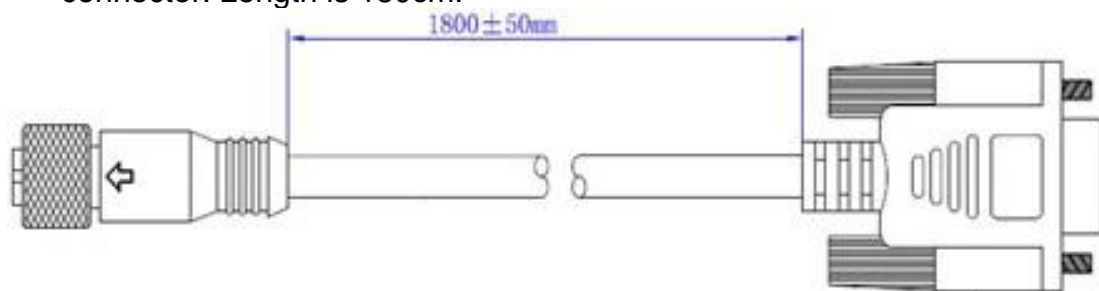

## 1.5 Specifications

|                               |  |
|-------------------------------|--|
| <b>Product</b>                | <b>SW-101-N</b>  |
| <b>Mainboard</b>              | SGT-MB3  |
| <b>Operating System</b>       | Windows 10 32-bit / 64-bit Enterprise<br>Windows 8.1 / 8<br>Windows 7 32-bit / 64-bit<br>WEC (Windows Embedded Compact) 2013<br>WEI (Windows Experience Index) 8.1 |
| <b>CPU</b>                    | Intel® Atom™ E3845 Quad Core 1.91GHz,<br>FCBGA1170   |
| <b>Chipset</b>                | SoC integrated   |
| <b>Memory</b>                 | 1 x DDR3L SO-DIMM 1333 MHz, expandable to 8 GB<br>(Non-ECC)  |
| <b>Graphics</b>               | Intel® HD graphics Gen. 7-LP 4EU   |
| <b>LAN Controller</b>         | 1 x Realtek RTL8111H GbE LAN Controller  |
| <b>Super I/O</b>              | Nuvoton NCT5523D   |
| <b>Storage</b>                | 1 x mSATA slot   |
| <b>Power Requirement</b>      | DC-In 12V  |
| <b>Power Supply</b>           | 84W power adapter (Optional)   |
| <b>Watchdog</b>               | Watchdog Timer 256 segments, 0, 1, 2...255 sec/min   |
| <b>Chassis</b>                | Aluminum die-casting and heavy-duty steel, black   |
| <b>Mounting</b>               | Wall mount   |
| <b>Dimensions (W x H x D)</b> | 227 x 70x 192 mm (8.93" x 2.75" x 7.55")   |
| <b>Net Weight</b>             | 2.8 kg (6.17 lb)   |
| <b>Certificate</b>            | CE, FCC class B, CCC   |

| I/O Ports                   |   |
|-----------------------------|---|
| <b>Power</b>                | 1 x DC-In power connector (M12 to 3-pin terminal block)   |
| <b>Display Interface</b>    | 1 x HDMI (C3 connector)   |
| <b>LAN</b>                  | 1 x GbE LAN (M12 to RJ45)   |
| <b>Serial</b>               | 1 x COM RS-232 (M12 to D-Sub9)  |
| <b>USB</b>                  | 2 x USB 2.0 (M12 connector)   |
| <b>Digital I/O</b>          | 1 x 4-In/ 4-Out Digital I/O (M12 to open wire)  |
| <b>Antenna</b>              | 2 x Antenna openings for jack type with waterproof design   |
| <b>Expansion</b>            | <ul style="list-style-type: none"> <li>• 1 x Mini-PCle (half/full-size) for WiFi / 3G / 4G LTE options</li> <li>• 1 x Mini-PCle (half/full-size) for mSATA SSD</li> </ul> |
| Environment                 |   |
| <b>Temperature</b>          | <ul style="list-style-type: none"> <li>• <b>Operating:</b> -40 ~ 75 °C (-40 ~ 167 °F)</li> <li>• <b>Storage:</b> -20 ~ 80 °C (-4 ~ 176 °F)</li> </ul>                     |
| <b>Relative Humidity</b>    | 10 ~ 90% at 45 °C (non-condensing)  |
| <b>Vibration Protection</b> | mSATA: random operation 5 grms, 5~500 Hz  |

All specifications are subject to change without prior notice.

---

**Note:** The product performance relies on the system functioning as a whole. The level of CPU/APU/GPU processor, the interaction among the processor and the memory and storage bandwidth, or the functionality of the digital signage application software may affect the product performance.

---

## 1.6 Product View

### Front View

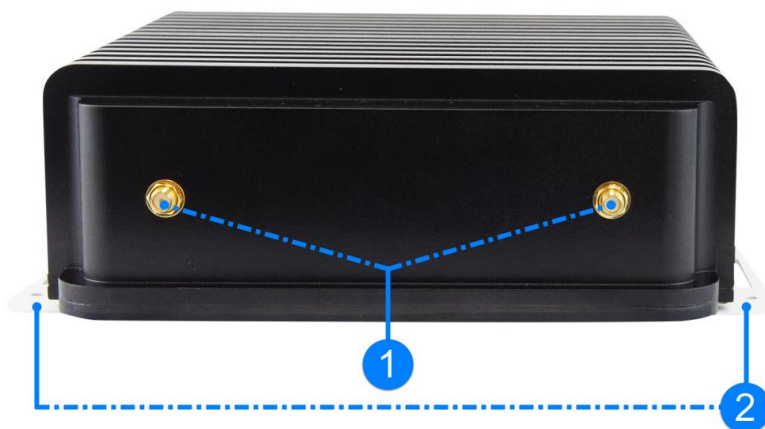

| No. | Name          | No. | Name           |
|-----|---------------|-----|----------------|
| 1   | Antenna Holes | 2   | Wall Mount Kit |

### Rear View



| No. | Name                  | No. | Name   |
|-----|-----------------------|-----|--|
| 1   | HDMI Port (C3)        | 4   | Digital I/O Port (M12 to open wire)          |
| 2   | USB 2.0 Ports (M12)   | 5   | GbE LAN Port (M12)                           |
| 3   | COM RS-232 Port (M12) | 6   | DC Power Input (M12 to 3-pin terminal block) |

**Oblique View**



**1.7 Dimensions**

Unit: mm

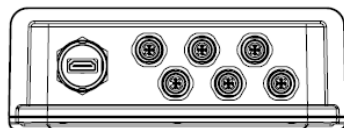
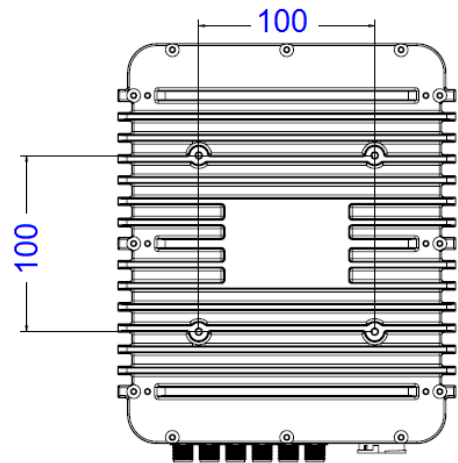
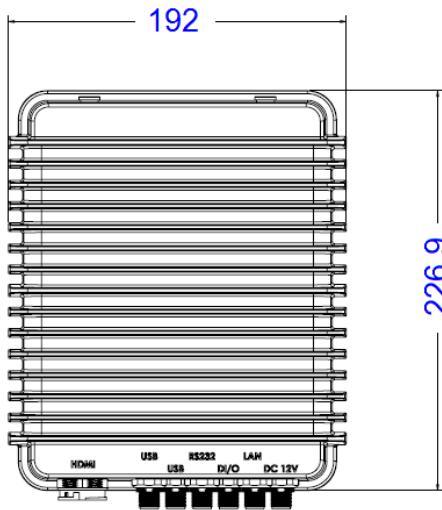
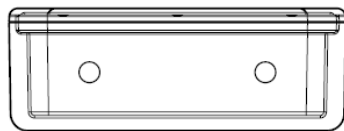

## **Chapter 2**

# **Hardware Installation & Motherboard Information**

The information provided in this chapter includes:

- Installation or replacement
- Information and locations of connectors

## 2.1 Installation / Replacement

Before doing any installation or any card/module replacement, loosen the 12 screws (show bellows) to remove the chassis bottom.

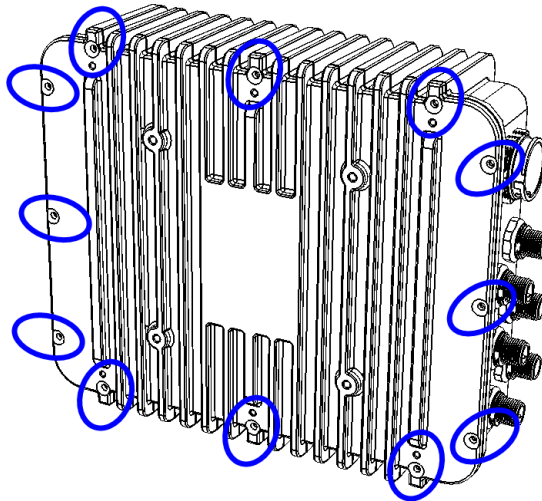

### 2.1.1 Memory

To install the modules, locate the memory slot on the motherboard and perform the following steps:

1. Press the ejector tab of the memory slot down and outwards with your fingertips.

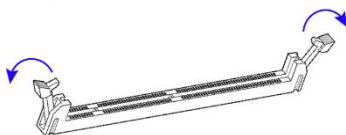

2. Hold the memory module and align the key of the module with that on the memory slot.
3. Gently push the module in an upright position until the ejector tabs of the memory slot close to hold the module in place when the module touches the bottom of the slot.

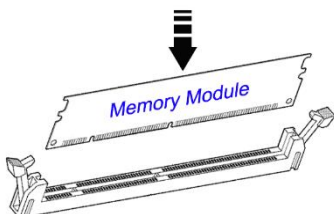

To remove the module, press the ejector tabs outwards with your fingertips to eject the module.

### 2.1.2 Mini-PCle Cards

1. Locate the mini-PCle or M.2 slot inside the device.
2. Align the key of the mini-PCle card to the mini-PCle interface, and insert the card slantwise. (Insert the M.2 card in the same way.)

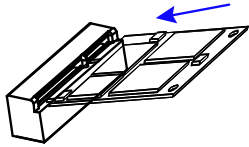

3. Push the mini-PCle card down and fix it with the an M2 screw. (Fix the M.2 network card with an M3 screw.)

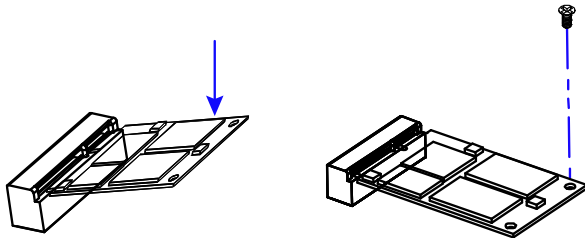

### 2.1.3 WiFi / 3G / 4G Antenna Installation

Thread the WiFi / 3G / 4G antenna extension cable through an antenna hole of the front I/O cover and fasten the antenna as shown below. Then apply adhesive to the edge of the hex nut behind the front I/O cover to prevent the extension cable from falling if the cable becomes loose.

1. Thread and fasten the hex nut and the washer. Then install the antenna.

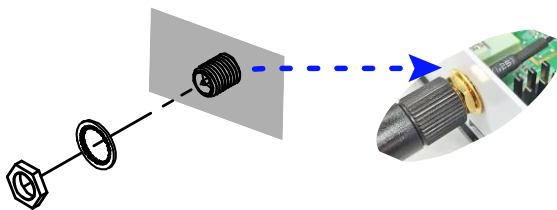

2. Apply adhesive around here.

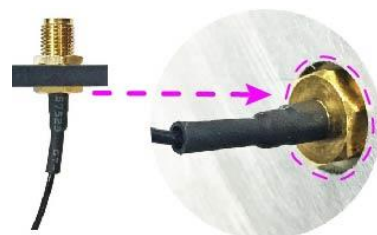



---

**Info:** The diameter of the nut is around 6.35 mm (0.25"-36UNC).

---

## 2.1.4 Wall Mount Installation

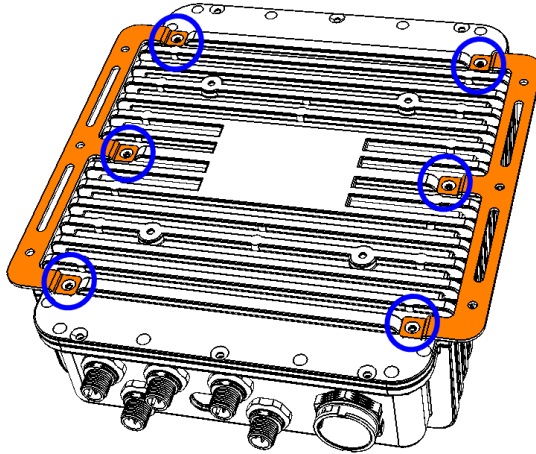
1. Turn the device upside down. Attach the wall-mount kit (2 brackets) to the device and secure it with the supplied 6 screws.



2. Prepare 4 screws (M3) to install the device on the wall, as shown.

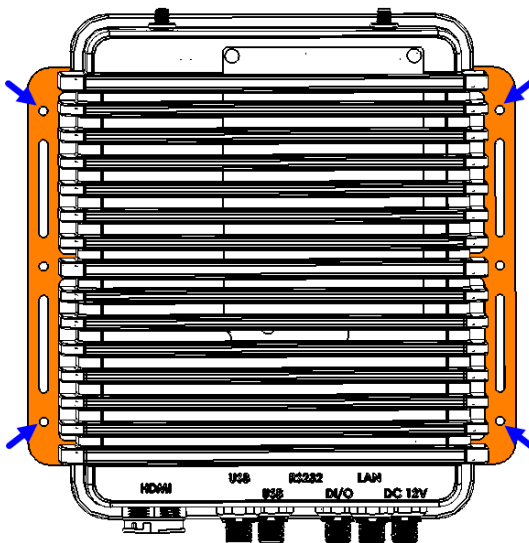

## 2.2 Pinout for DC Power Input Connector



DC Power Input Cable: M12 to 3-pin terminal block

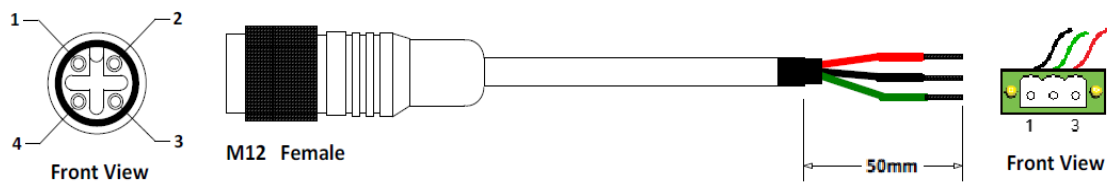

The DC power input cable is an optional accessory.

M12 end:

| Pin | Signal Name | Pin | Signal Name |
|-----|-------------|-----|-------------|
| 1   | Voltage+    | 2   | Voltage-    |
| 3   | NC          | 4   | Ground      |

Terminal block end:

| Pin | Signal Name      | Pin | Signal Name    |
|-----|------------------|-----|----------------|
| 1   | Voltage- (Black) | 2   | Ground (Green) |
| 3   | Voltage+ (Red)   |     |                |

### 2.3 Pinout for Digital I/O Connector



Digital I/O Cable: M12 to open wire

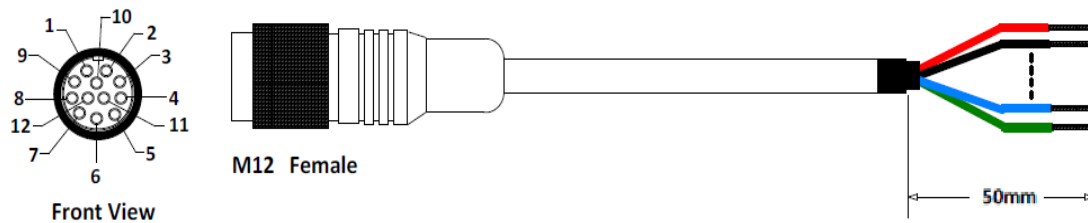

The Digital I/O cable is an optional accessory.

| M12 end |             | Open Wire end |
|---------|-------------|---------------|
| Pin     | Signal Name | Pin           |
| 1       | IN0         | User-defined  |
| 2       | Ground      |               |
| 3       | IN1         |               |
| 4       | Ground      |               |
| 5       | IN2         |               |
| 6       | Ground      |               |
| 7       | IN3         |               |
| 8       | Ground      |               |
| 9       | IN4         |               |
| 10      | Ground      |               |
| 11      | OUT1        |               |
| 12      | Ground      |               |

## 2.4 Pinout for COM1 RS-232 Port



Serial Cable: M12 to D-Sub9

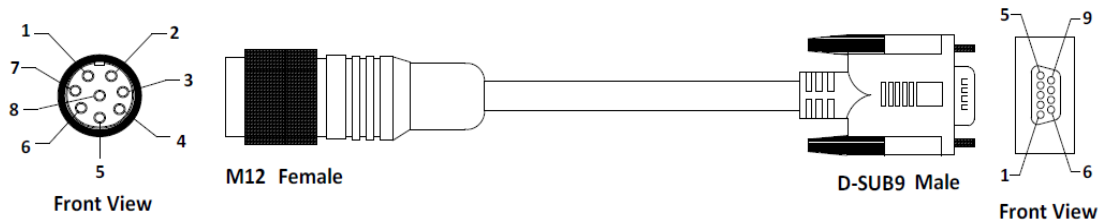

The serial cable is an optional accessory.

| M12 end |             | D-Sub-end |
|---------|-------------|-----------|
| Pin     | Signal Name | Pin       |
| 1       |             | 1         |
| 2       | RxD         | 2         |
| 3       | TxD         | 3         |
| 4       |             | 4         |
| 5       | Ground      | 5         |
| 6       |             | 6         |
| 7       | RTS         | 7         |
| 8       | CTS         | 8         |
| 9       |             | 9         |

**2.5 Pinout for LAN Port (M12)**

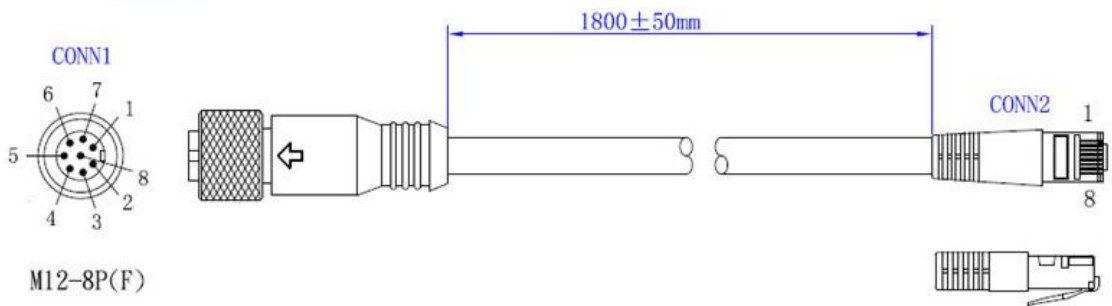

| CONN1 |             | CONN2        |       |
|-------|-------------|--------------|-------|
| Pin   |             | Color        | Pin   |
| 1     | Intertwined | White Orange | 1     |
| 7     |             | Orange       | 2     |
| 8     | Intertwined | White Green  | 3     |
| 5     |             | Green        | 6     |
| 3     | Intertwined | Blue         | 4     |
| 2     |             | White Blue   | 5     |
| 6     | Intertwined | White Brown  | 7     |
| 4     |             | Brown        | 8     |
| Shell |             | Ground       | Shell |

## 2.6 Pinout for USB Ports (M12)



One end of the cable is an M12 connector and the other end is a USB connector. Length is 180cm.

**Part Number:** C501USB1620A12000P

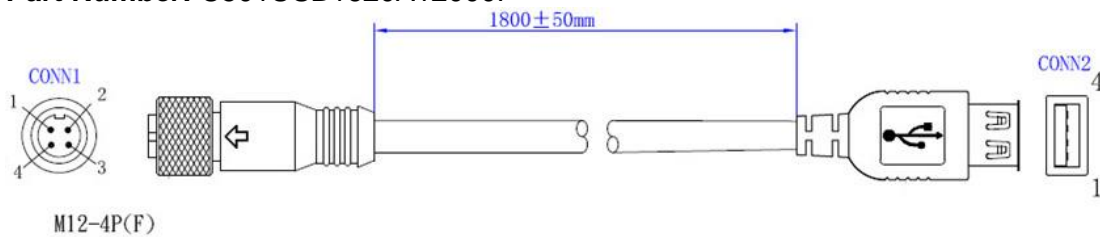

| CONN1 |             | CONN2  |       |
|-------|-------------|--------|-------|
| Pin   |             | Color  | Pin   |
| 1     |             | Red    | 1     |
| 2     | Intertwined | White  | 2     |
| 3     |             | Green  | 3     |
| 4     |             | Black  | 4     |
| Shell |             | Ground | Shell |

## 2.7 Setting the Jumpers

Set up and configure the SW-101-N with the jumpers on board according to your needs and applications. Contact your supplier if you have doubts about the best configuration for your use.

### 2.5.1 How to Set Jumpers

Jumpers are short-length conductors consisting of several metal pins with a non-conductive base mounted on the circuit board. Jumper caps are used to have the functions and features enabled or disabled. If a jumper has 3 pins, you can connect either PIN1 to PIN2 or PIN2 to PIN3 by shorting.

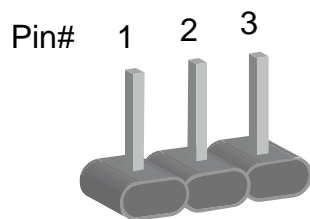

**A 3-pin jumper**

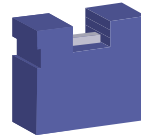

**A jumper cap**

Refer to the illustration below to set jumpers.

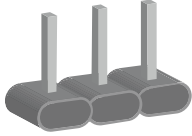
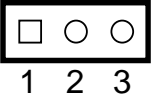
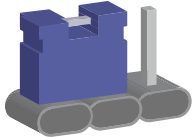
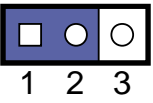
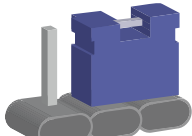
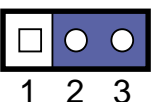
| Pin closed | Oblique view  | Illustration   |
|------------|---|--|
| Open       |  | <br>1 2 3 |
| 1-2        |  | <br>1 2 3 |
| 2-3        |  | <br>1 2 3 |

When two pins of a jumper are encased in a jumper cap, this jumper is **closed**, i.e. turned **On**.

When a jumper cap is removed from two jumper pins, this jumper is **open**, i.e. turned **Off**.



## 2.9 Jumpers Quick Reference

| Function             | Connector     | Page |
|----------------------|---------------|------|
| Clearing CMOS Data   | JP4           | 23   |
| Clearing ME Register | JP5           | 24   |
| Factory Use Only     | JP1, JP2, JP3 | --   |

### 2.9.1 Clear CMOS Data (JP4)

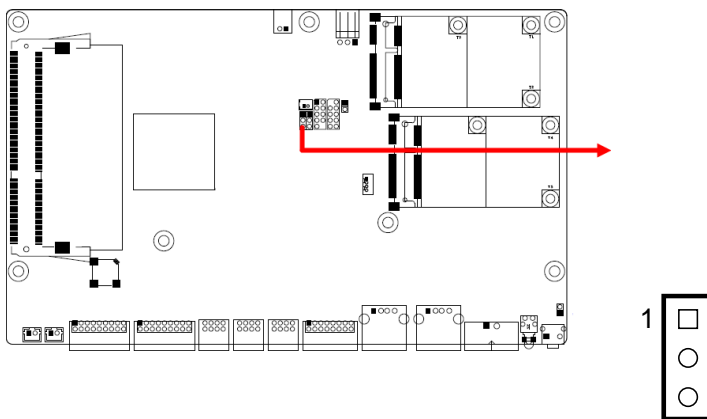

| Function         | Pin closed | Illustration |
|------------------|------------|--------------|
| Normal (default) | 1-2        | 1            |
| Clear CMOS       | 2-3        | 1            |

**2.9.2 Clear ME Register (JP5)**

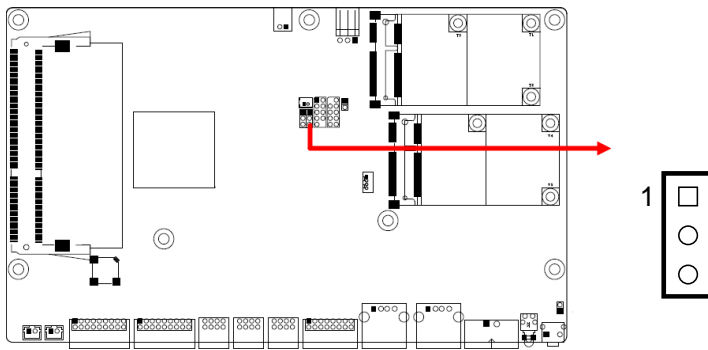

| Function         | Pin closed | Illustration |
|------------------|------------|--------------|
| Normal (default) | 1-2        | 1            |
| Clear ME         | 2-3        | 1            |

## 2.10 Connectors Quick Reference

| Function                    | Connector Name                   | Page |
|-----------------------------|----------------------------------|------|
| Board Input Power Connector | CN4                              | 24   |
| 5V Power Connector          | J1                               | 25   |
| RTC Battery Connector       | J3                               | 25   |
| Reset Connector             | J8                               | 25   |
| Speaker Connector           | J9 (left), J10 (right)           | 26   |
| COM RS-232 Connector        | J11, J12                         | 26   |
| LAN Connector               | J13                              | 28   |
| HDMI Connector              | J14, J15                         | 28   |
| Digital I/O Connector       | J16                              | 28   |
| System Fan Power Connector  | SYS_FAN1                         | 28   |
| Power Button                | SW1                              | --   |
| Power LED Indicator         | LED1                             | --   |
| USB 2.0 Connector           | CN2, CN3                         | --   |
| Mini-PCIe Slot              | J2 (wireless),<br>J5 (for mSATA) | --   |
| DDR3L Memory Slot           | J4                               | --   |
| Factory Use Only            | J17                              | --   |

### 2.8.1 Board Input Power Connector (CN4)

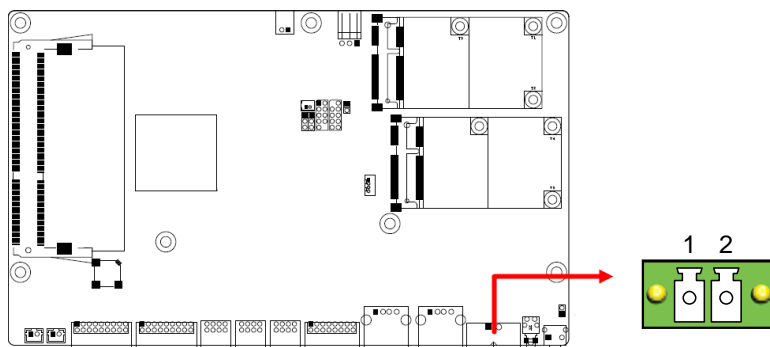

| Pin | Signal Name | Pin | Signal Name |
|-----|-------------|-----|-------------|
| 1   | 12V         | 2   | Ground      |

### 2.8.2 5V Power Connector (J1)

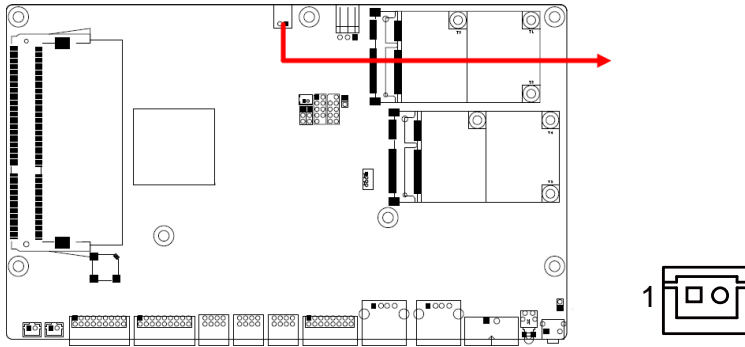

| Pin | Signal Name | Pin | Signal Name |
|-----|-------------|-----|-------------|
| 1   | 5V          | 2   | Ground      |

### 2.8.3 RTC Battery Connector (J3)

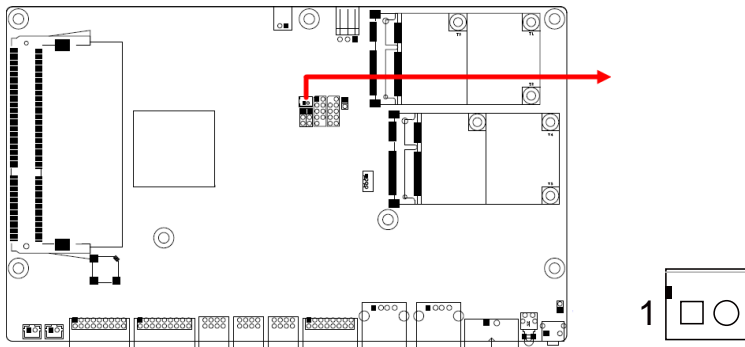

| Pin | Signal Name | Pin | Signal Name |
|-----|-------------|-----|-------------|
| 1   | Battery+    | 2   | Ground      |

### 2.8.4 Reset Connector (J8)

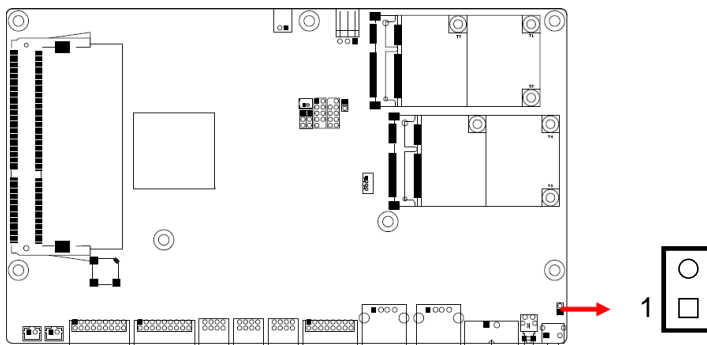

| Pin | Signal Name | Pin | Signal Name |
|-----|-------------|-----|-------------|
| 1   | Reset       | 2   | Ground      |

### 2.8.5 Speaker Connector (J9, J10)

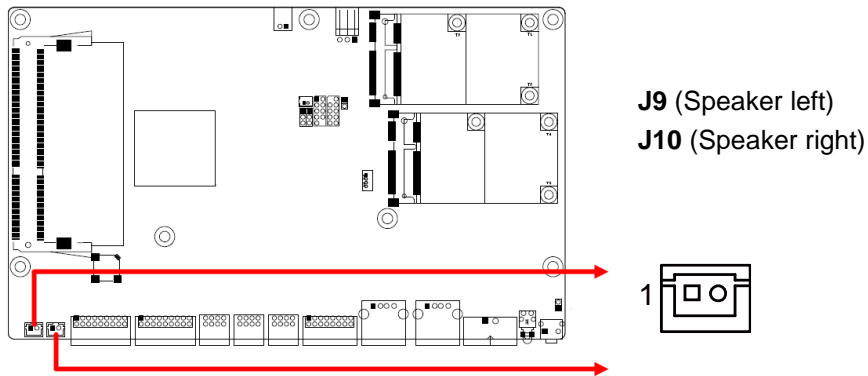

J9: Speaker left

| Pin | Signal Name | Pin | Signal Name |
|-----|-------------|-----|-------------|
| 1   | SPK-L+      | 2   | SPK-L-      |

J10: Speaker right

| Pin | Signal Name | Pin | Signal Name |
|-----|-------------|-----|-------------|
| 1   | SPK-R+      | 2   | SPK-R-      |

### 2.8.6 COM RS-232 Connector (J11, J12)

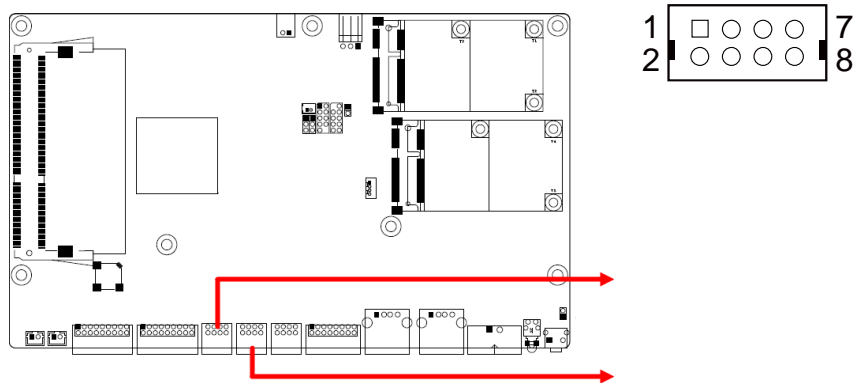

| Pin | Signal Name | Pin | Signal Name |
|-----|-------------|-----|-------------|
| 1   | SIN         | 2   | SOUT        |
| 3   | Ground      | 4   | NC          |
| 5   | RTS         | 6   | CTS         |
| 7   | NC          | 8   | NC          |

### 2.8.7 LAN Connector (J13)

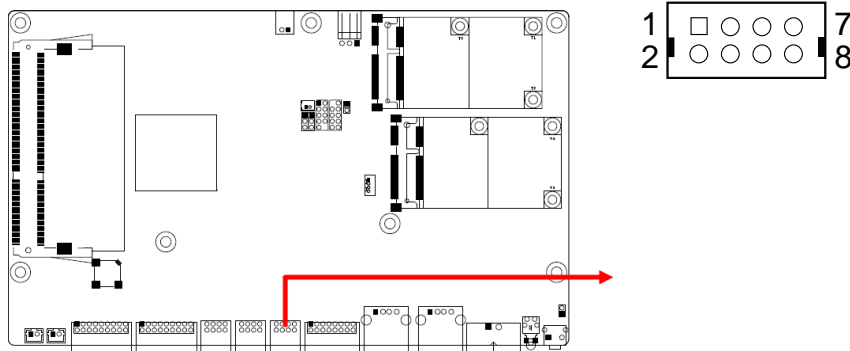

| Pin | Signal Name | Pin | Signal Name |
|-----|-------------|-----|-------------|
| 1   | MDI3+       | 2   | MDI3-       |
| 3   | MDI2+       | 4   | MDI2-       |
| 5   | MDI1+       | 6   | MDI1-       |
| 7   | MDI0+       | 8   | MDI0-       |

### 2.8.8 HDMI Connector (J14, J15)

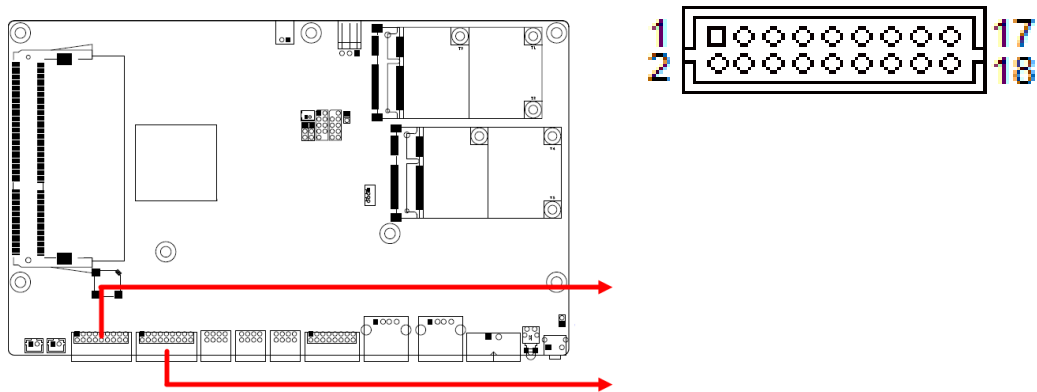

| Pin | Signal Name   | Pin | Signal Name   |
|-----|---------------|-----|---------------|
| 1   | TMDS_DATA2_P  | 2   | TMDS_DATA2_N  |
| 3   | Ground        | 4   | Ground        |
| 5   | TMDS_DATA1_P  | 6   | TMDS_DATA1_N  |
| 7   | Ground        | 8   | Ground        |
| 9   | TMDS_DATA0_P  | 10  | TMDS_DATA0_N  |
| 11  | Ground        | 12  | Ground        |
| 13  | TMDS_CLK_P    | 14  | TMDS_CLK_N    |
| 15  | Ground        | 16  | Ground        |
| 17  | +5V_CON_R     | 18  | HPD_ESD       |
| 19  | TMDS_SCL_SINK | 20  | TMDS_SDA_SINK |

### 2.8.9 Digital I/O Connector (J16)

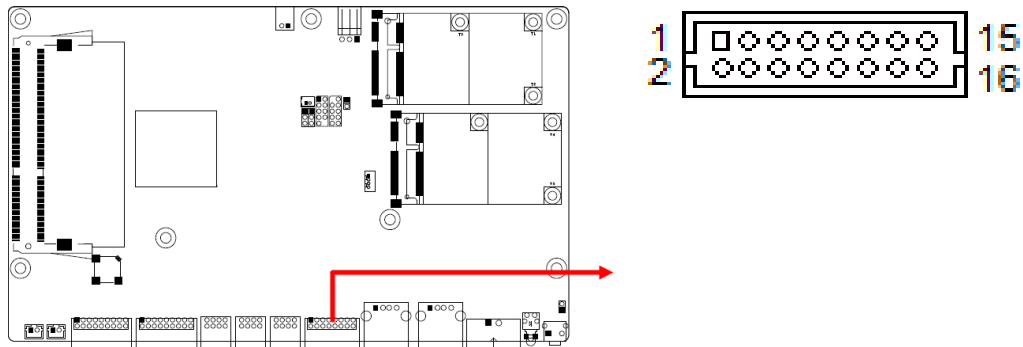

| Pin | Signal Name | Pin | Signal Name |
|-----|-------------|-----|-------------|
| 1   | IN0         | 2   | Ground      |
| 3   | IN1         | 4   | Ground      |
| 5   | IN2         | 6   | Ground      |
| 7   | IN3         | 8   | Ground      |
| 9   | IN4         | 10  | Ground      |
| 11  | IN5         | 12  | Ground      |
| 13  | IN6         | 14  | Ground      |
| 15  | OUT1        | 16  | Ground      |

### 2.8.10 System Fan Power Connector (SYS\_FAN1)

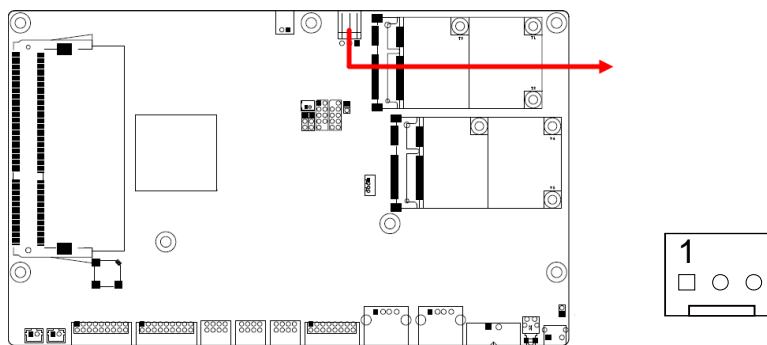

| Pin | Signal Name | Pin | Signal Name |
|-----|-------------|-----|-------------|
| 1   | Ground      | 3   | N/A         |
| 2   | +12V        |     |             |

## Chapter 3

# Driver Installation

The information provided in this chapter includes:

- Intel® Chipset Software Installation Utility
- Graphics Driver
- HD Audio Driver
- Intel® Trusted Execution Engine
- LAN Driver

### 3.1 Introduction

This section describes the installation procedures for software drivers. The software drivers are available on IBASE website [www.ibase.com.tw](http://www.ibase.com.tw). Go to the download page of the product. Copy the compressed drivers file to your computer. Double click the file to decompress it. Run “CDGuide” to go to the main drivers page.

---

**Note:** After installing your Windows operating system, you must install the Intel® Chipset Software Installation Utility first before proceeding with the drivers installation.

---

### 3.2 Intel® Chipset Software Installation Utility

The Intel® Chipset drivers should be installed first before the software drivers to install INF files for Plug & Play function for the chipset components. Follow the instructions below to complete the installation.

1. Run the **Setup.exe** file.
2. When the *Welcome* screen to the Intel® Chipset Device Software appears, click **Next** to continue.

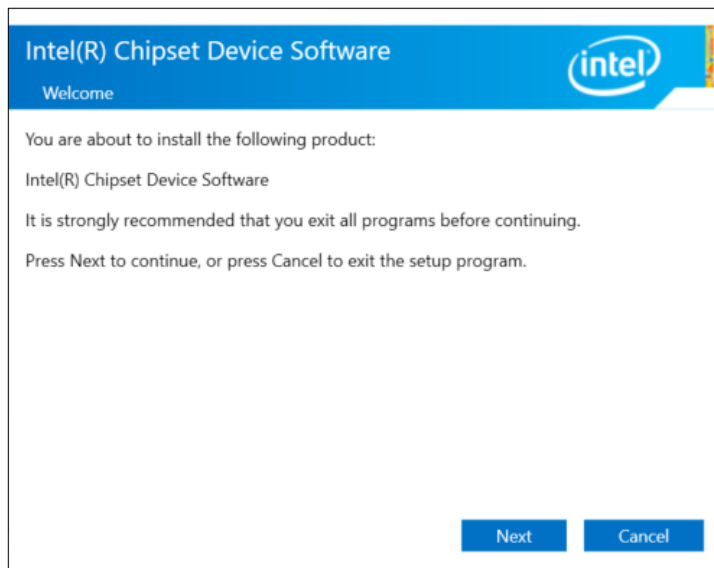

- 3. Accept the license agreement and proceed with the installation process.

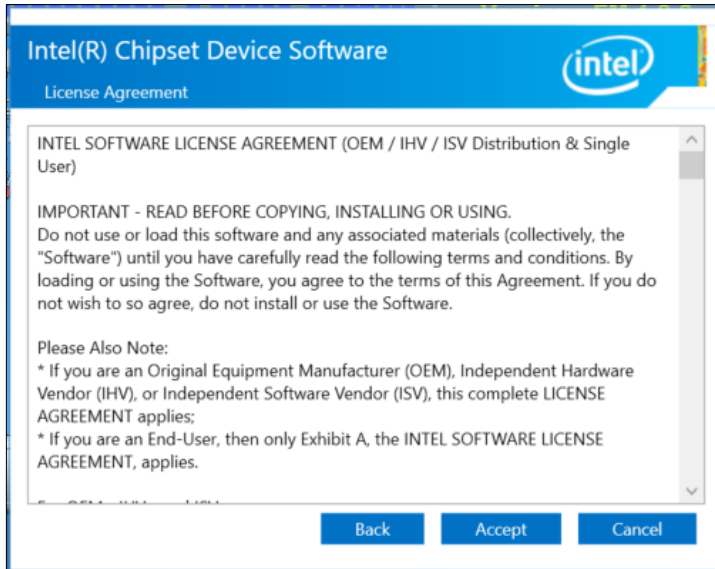

- 4. Click **Install**.

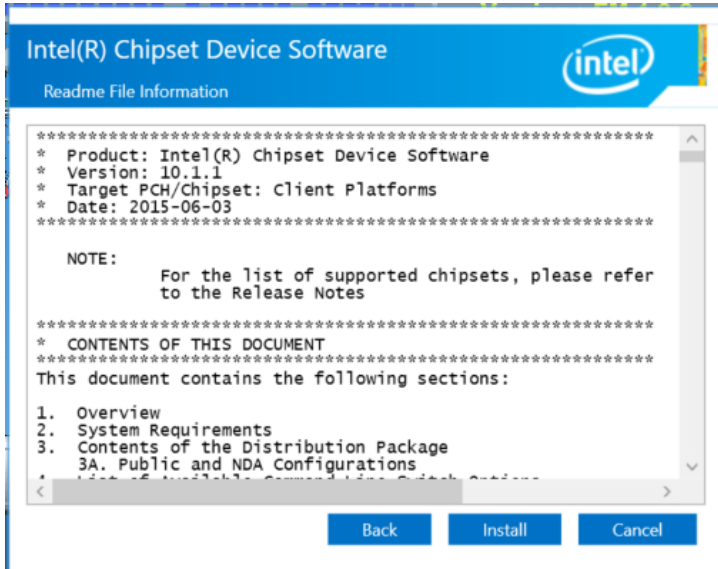

- 5. When the driver is completely installed, restart the computer for changes to take effect.

### 3.3 Graphics Driver Installation

1. Run the **Setup.exe** file.
2. On the *Welcome* screen, click **Next**.

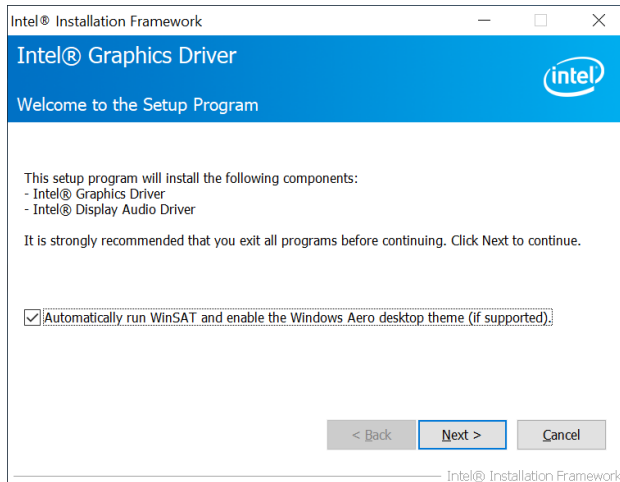

3. Accept the license agreement and click **Yes** to continue.

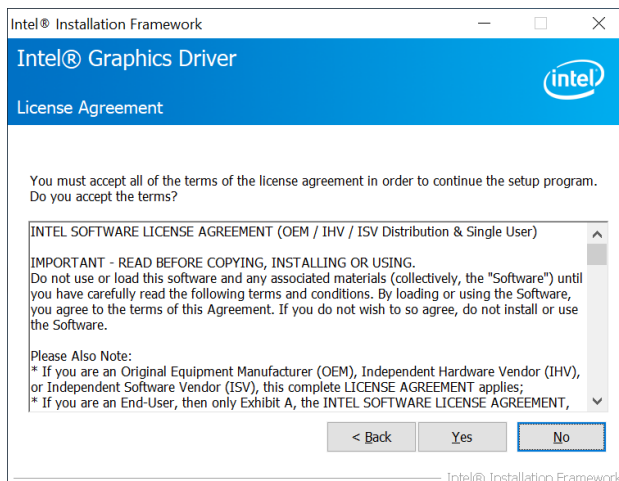

4. On the *Readme File Information*, click **Next**.

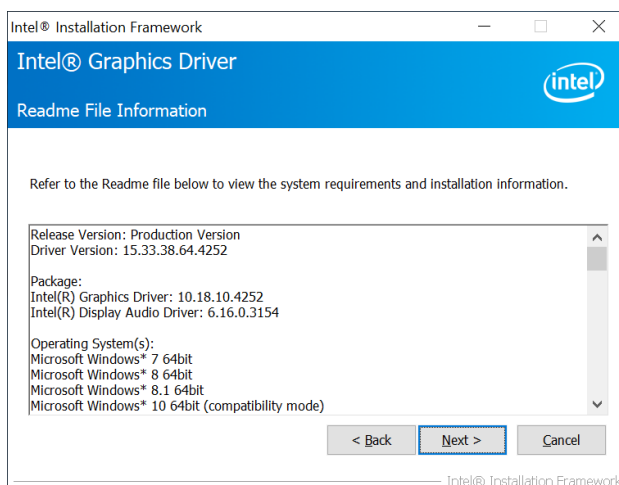

5. Click **Next** until the installation starts.

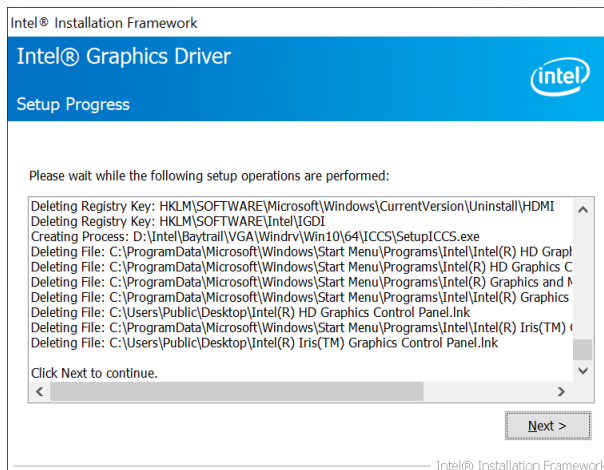

6. When the driver is completely installed, restart the computer for changes to take effect.

### 3.4 HD Audio Driver Installation

1. Run the **Setup.exe** file.
2. On the *Welcome* screen of the InstallShield Wizard, click **Next**.

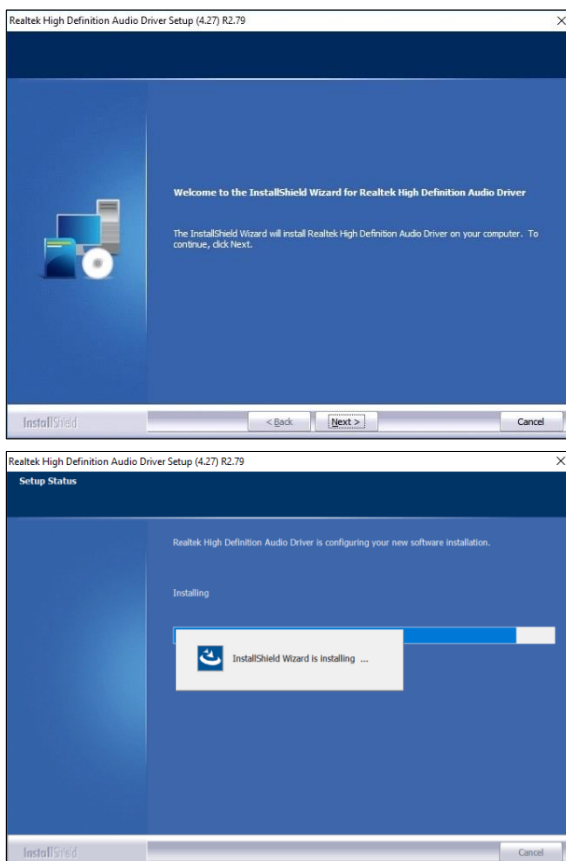

3. When the driver is completely installed, restart the computer for changes to take effect.

### 3.5 LAN Driver Installation

1. Run the **Setup.exe** file.
2. On the *Welcome* screen of the InstallShield Wizard, click **Next**.

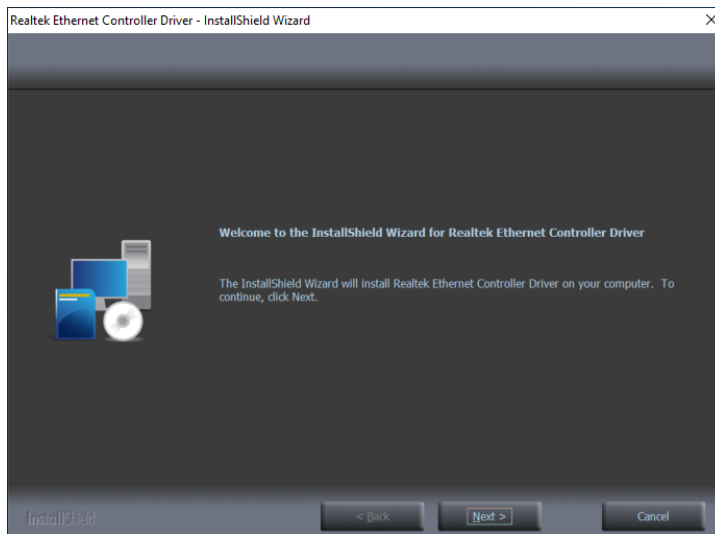

3. Click **Install**.

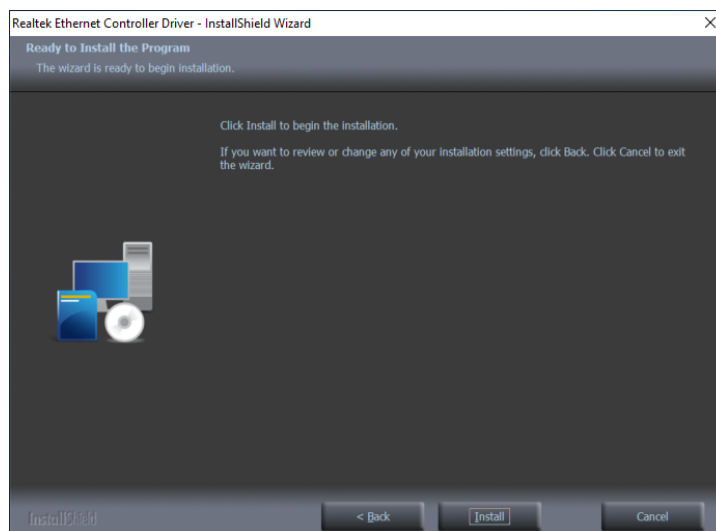

4. When the driver is completely installed, restart the computer for changes to take effect.

## 3.6 Intel® Trusted Execution Engine Drivers Installation

1. Run the **Setup.exe** file.
2. When the *Welcome* screen appears, click **Next**.

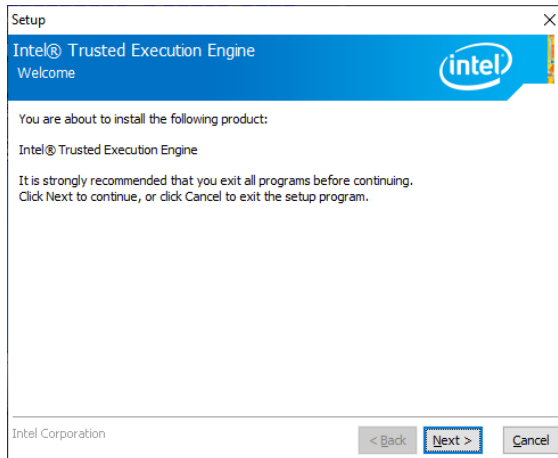

3. Accept the license agreement and click **Next** for installation.

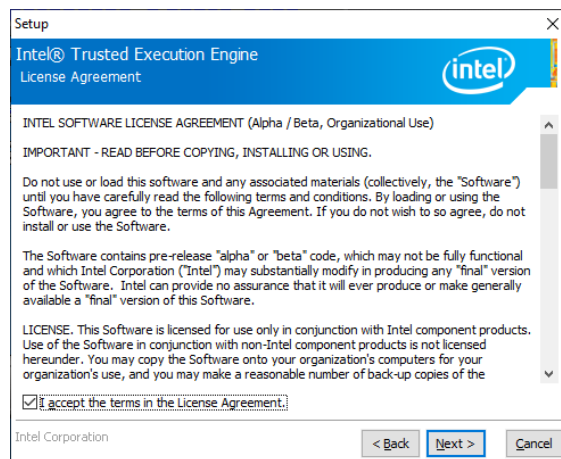

4. Click **Next** until the installation starts.

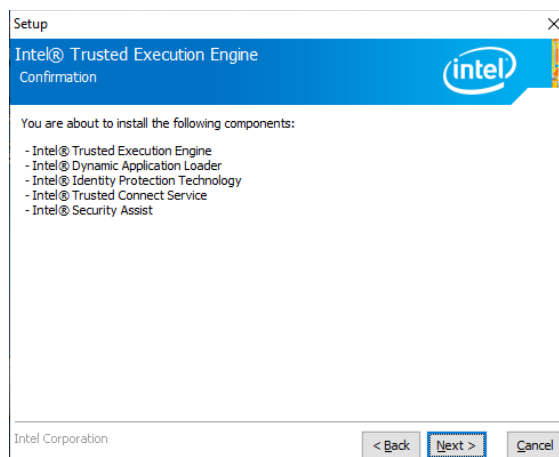

5. As the driver has been completely installed, restart the computer for changes to take effect.

## Chapter 4

# BIOS Setup

This chapter describes the different settings available in the AMI BIOS that comes with the board. The topics covered in this chapter are as follows:

- Main Settings
- Advanced Settings
- Chipset Settings
- Security Settings
- Boot Settings
- Save & Exit

## 4.1 Introduction

The BIOS (Basic Input/Output System) installed in the ROM of your computer system supports Intel® processors. The BIOS provides critical low-level support for standard devices such as disk drives, serial ports and parallel ports. It also provides password protection as well as special support for detailed fine-tuning of the chipset controlling the entire system.

## 4.2 BIOS Setup

The BIOS provides a Setup utility program for specifying the system configurations and settings. The BIOS ROM of the system stores the Setup utility. When you turn on the computer, the BIOS is immediately activated. Press the <Del> key immediately allows you to enter the Setup utility. If you are a little bit late pressing the <Del> key, POST (Power On-Self-Test) will continue with its test routines, thus preventing you from invoking the Setup. You can also press <F7> to call the pop-up Boot menu immediately.

If you still need to enter Setup, restart the system by pressing the "Reset" button or simultaneously pressing the <Ctrl>, <Alt> and <Delete> keys. You can also restart by turning the system Off and back On again.

The following message will appear on the screen:

```
Press <DEL> to Enter Setup
```

In general, press the arrow keys to highlight items, <Enter> to select, the <PgUp> and <PgDn> keys to change entries, <F1> for help, and <Esc> to quit.

When you enter the BIOS Setup utility, the *Main Menu* screen will appear on the screen. The Main Menu allows you to select from various setup functions and exit choices.

---

**Warning:** It is strongly recommended that you avoid making any changes to the chipset defaults.

These defaults have been carefully chosen by both AMI and your system manufacturer to provide the absolute maximum performance and reliability. Changing the defaults could make the system unstable and crash in some cases.

---

### 4.3 Main Settings

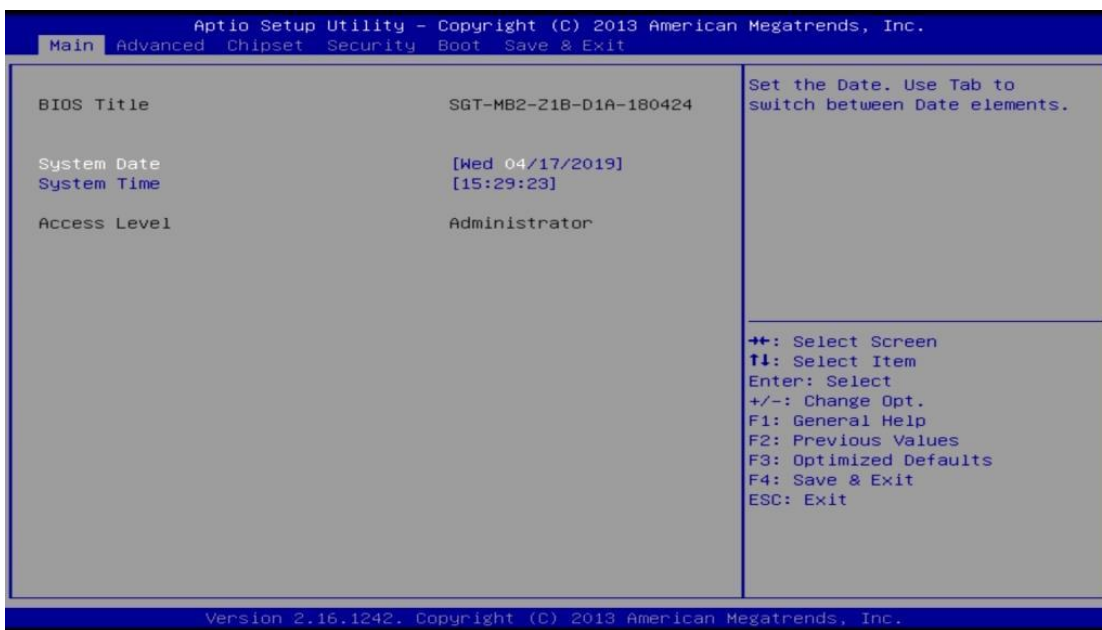

| BIOS Setting | Description  |
|--------------|--|
| System Date  | Sets the date.<br>Use the <Tab> key to switch between the date elements. |
| System Time  | Set the time.<br>Use the <Tab> key to switch between the time elements.  |

## 4.4 Advanced Settings

This section allows you to configure, improve your system and allows you to set up some system features according to your preference.

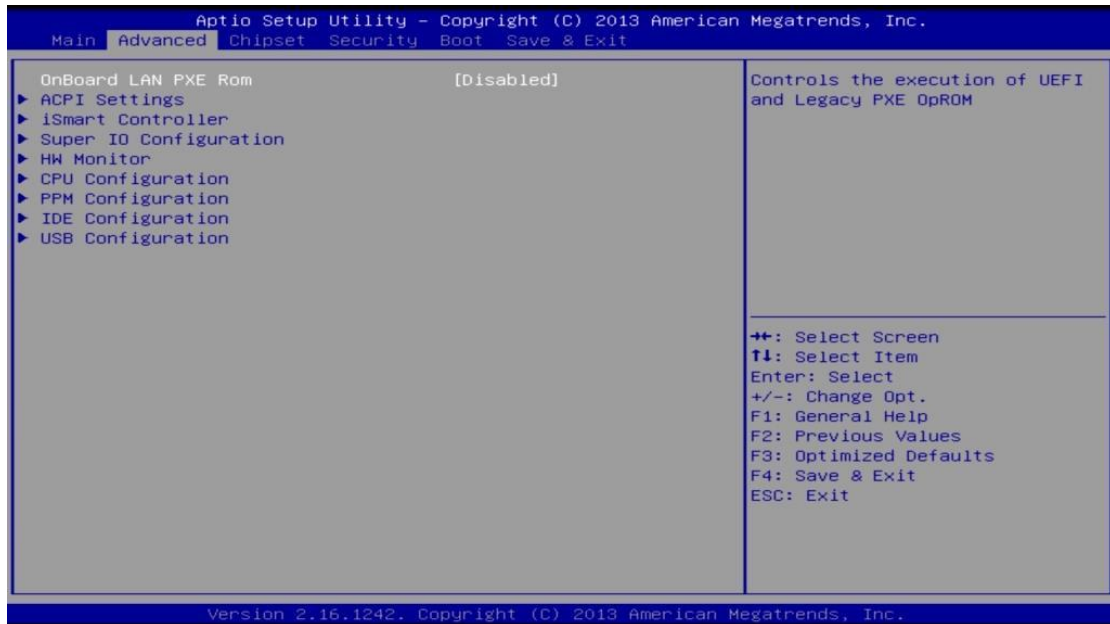

| BIOS Setting           | Description   |
|------------------------|---|
| OnBoard LAN PXE Rom    | Controls the execution of UEFI and Legacy PXE OpROM.  |
| ACPI Settings          | Displays the system ACPI parameters..                 |
| iSmart Controller      | Sets up the power on time for the system.             |
| Super IO Configuration | Displays the parameters of the system Super I/O chip. |
| HW Monitor             | Shows the monitor hardware status.                    |
| CPU Configuration      | Presents the parameters of the CPU configuration.     |
| PPM Configuration      | Shows the parameters of PPM configuration.            |
| IDE Configuration      | Configures the IDE devices.                           |
| USB Configuration      | Shows the parameters of USB configuration.            |

### 4.4.1 ACPI Settings

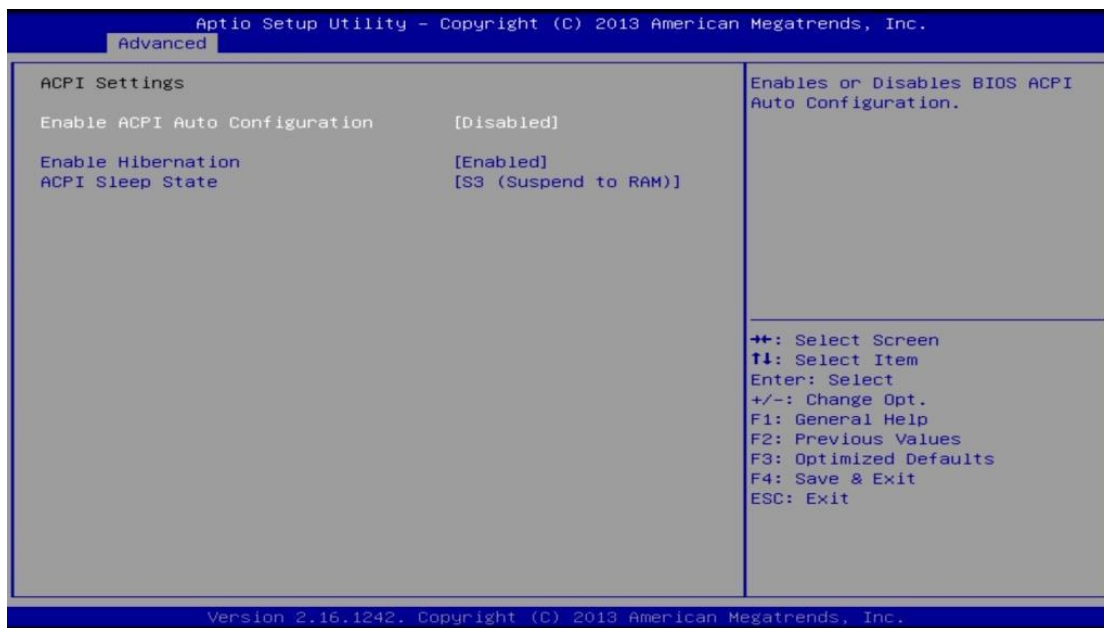

| BIOS Setting                   | Description   |
|--------------------------------|---|
| Enable ACPI Auto Configuration | Enables / Disables BIOS ACPI Auto configuration.  |
| Enable Hibernation             | Enables / Disables system ability to hibernate (OS/S4 Sleep State). This option may not be effective with some operating systems. |
| ACPI Sleep State               | Selects the highest ACPI sleep state the system will enter when the SUSPEND button is pressed.                                    |

**4.4.2 iSmart Controller**

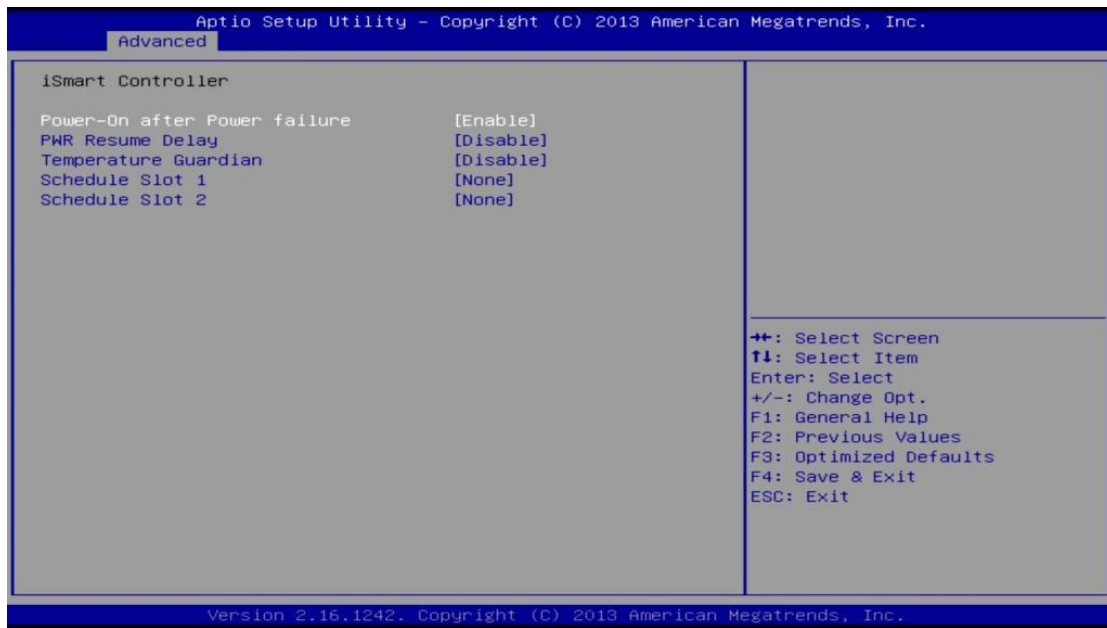

| BIOS Setting                 | Description  |
|------------------------------|--|
| Power-On after Power failure | Enables / Disables the system to be turned on automatically after a power failure.   |
| PWR Resume Delay             | Enables / Disables power on resume delay.  |
| Temperature Guardian         | Generates the reset signal when system hands up on POST.   |
| Schedule Slot 1 / 2          | <p>Sets up the hour / minute for system powe-on.</p> <p><b>Important:</b> If you would like to set up a schedule between adjacent days, configure two schedule slots.</p> <p>For example, if setting up a schedule from Wednesday 5 p.m. to Thursday 2 a.m., configure two schedule slots. But if setting up a schedule from 3 p.m to 5 p.m. on Wednesday, configure only a schedule slot.</p> |

### 4.4.3 Super IO Configuration

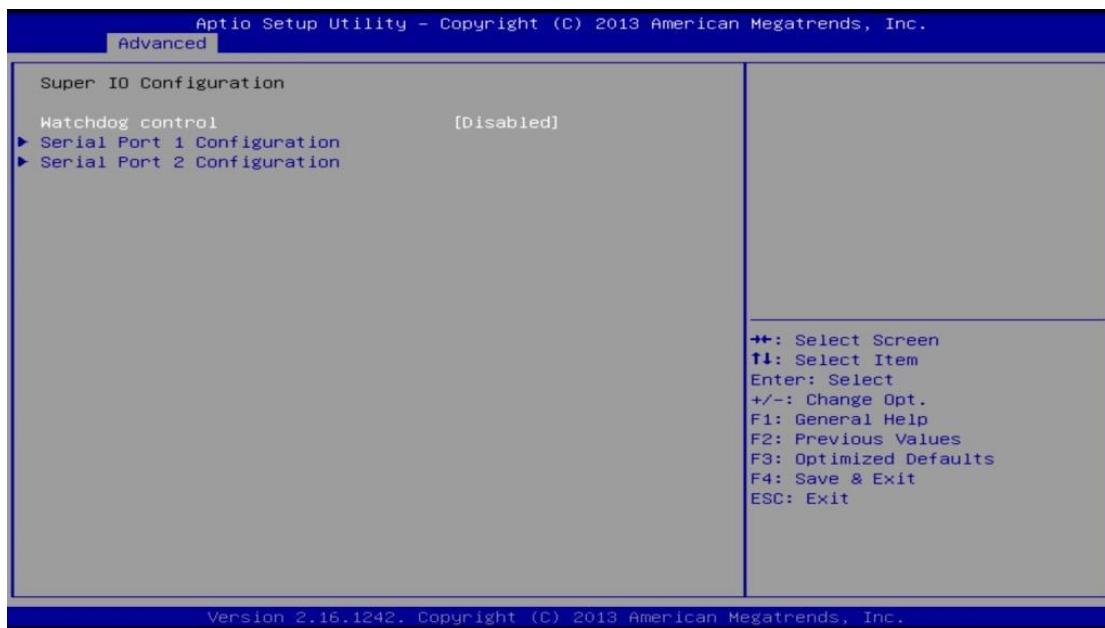

| BIOS Setting                    | Description  |
|---------------------------------|--|
| Watchdog Control                | Controls the Watchdog.<br>Options: Disabled, 30 sec, 60 sec, 90 sec, 120 sec   |
| Serial Port 1 & 2 Configuration | Sets parameters of Serial Port 1 & 2 (COMA & COMB).<br><br>Enables / Disables the serial port and select an optimal setting for the Super IO device. |

**4.4.3.1. Serial Port 1 Configuration**

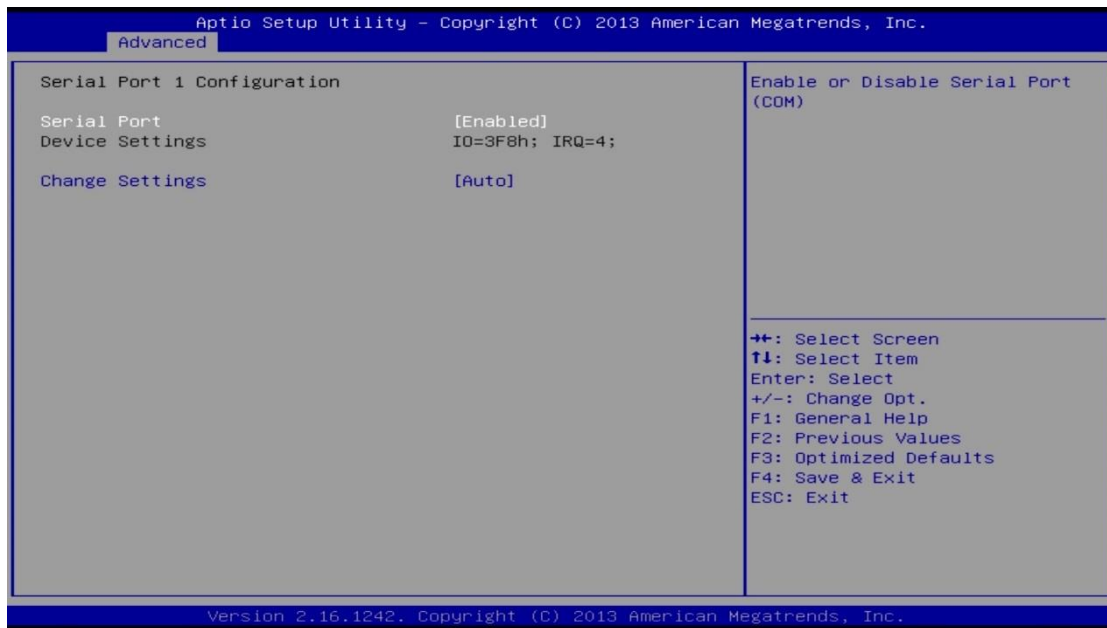

| BIOS Setting    | Description   |
|-----------------|---|
| Serial Port     | Enables / Disables serial port (COM).   |
| Change Settings | <p>Selects an optimal settings for Super I/O device.</p> <p>Options:</p> <ul style="list-style-type: none"> <li>• Auto</li> <li>• IO = 3F8h; IRQ = 4</li> <li>• IO = 3F8h; IRQ = 3, 4, 5, 6, 7, 9, 10, 11, 12</li> <li>• IO = 2F8h; IRQ = 3, 4, 5, 6, 7, 9, 10, 11, 12</li> <li>• IO = 3E8h; IRQ = 3, 4, 5, 6, 7, 9, 10, 11, 12</li> <li>• IO = 2E8h; IRQ = 3, 4, 5, 6, 7, 9, 10, 11, 12</li> </ul> |

### 4.4.3.2. Serial Port 2 Configuration

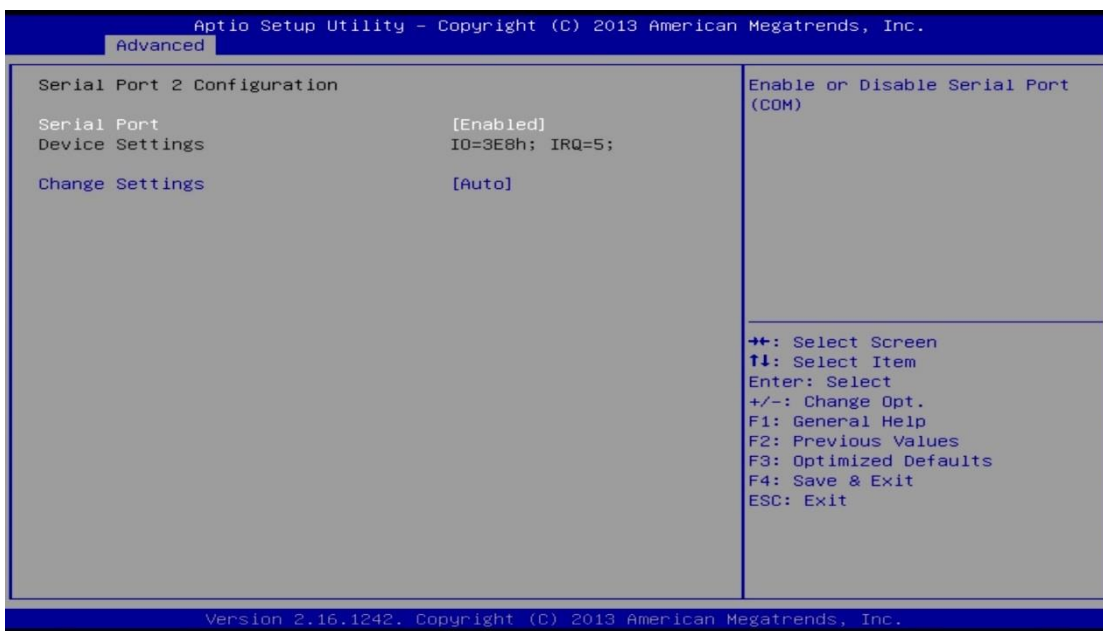

| BIOS Setting    | Description   |
|-----------------|---|
| Serial Port     | Enables / Disables serial port (COM).   |
| Change Settings | <p>Selects an optimal settings for Super I/O device.</p> <p>Options:</p> <ul style="list-style-type: none"> <li>• Auto</li> <li>• IO = 3E8h; IRQ = 3</li> <li>• IO = 3E8h; IRQ = 3, 4, 5, 6, 7, 9, 10, 11, 12</li> <li>• IO = 2E8h; IRQ = 3, 4, 5, 6, 7, 9, 10, 11, 12</li> <li>• IO = 2F0h; IRQ = 3, 4, 5, 6, 7, 9, 10, 11, 12</li> <li>• IO = 2E0h; IRQ = 3, 4, 5, 6, 7, 9, 10, 11, 12</li> </ul> |
| Device Mode     | Serial port 1 loop back / RS232 / RS422 / RS485 mode select.  |

**4.4.4 HW Monitor**

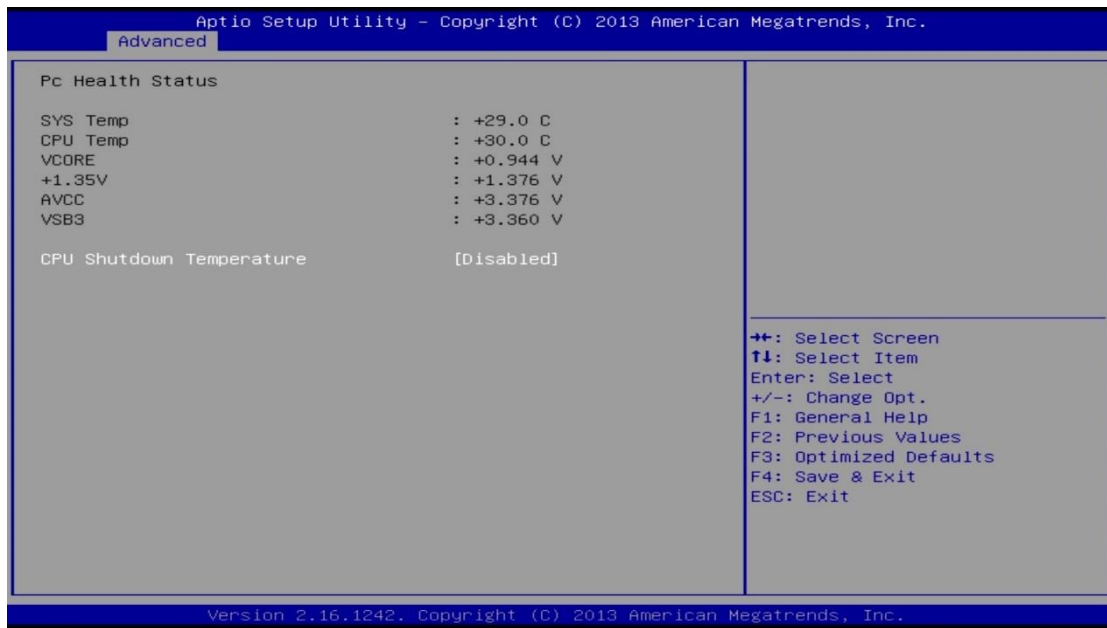

| BIOS Setting             | Description   |
|--------------------------|---|
| CPU Shutdown Temperature | Disables or sets system shutdown temperature to 70°C, 75°C, 80°C, 85°C, 90°C or 95°C.   |
| Temperatures / Voltages  | These fields are the parameters of the hardware monitoring function feature of the motherboard. The values are read-only values as monitored by the system and show the PC health status. |

### 4.4.5 CPU Configuration

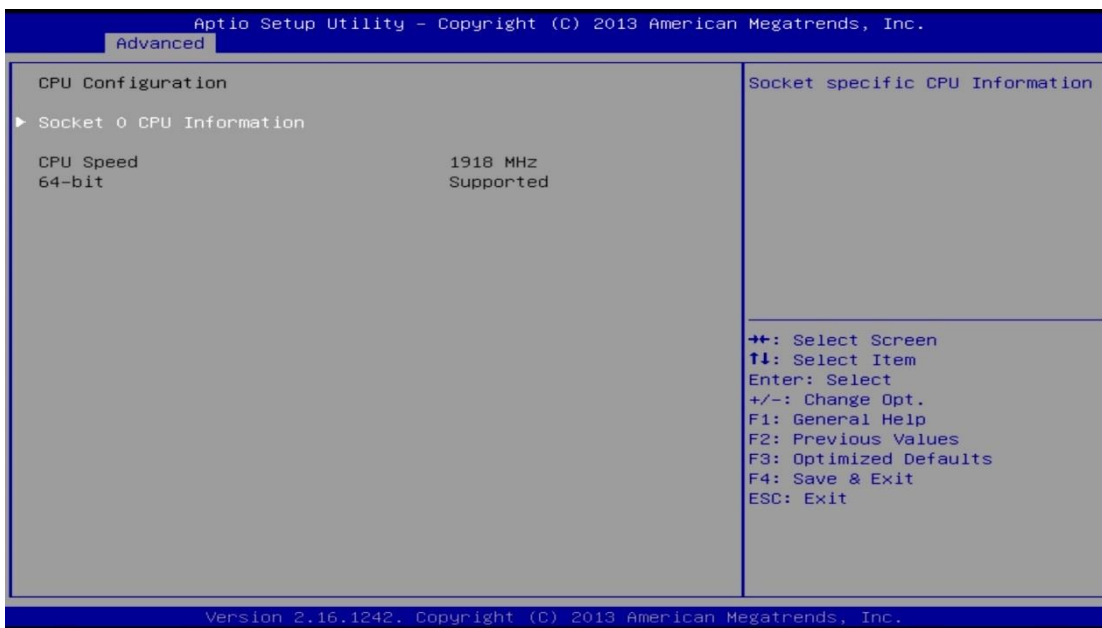

| BIOS Setting             | Description                     |
|--------------------------|---------------------------------|
| Socket 0 CPU Information | Socket specific CPU Information |

### 4.4.6 PPM Configuration

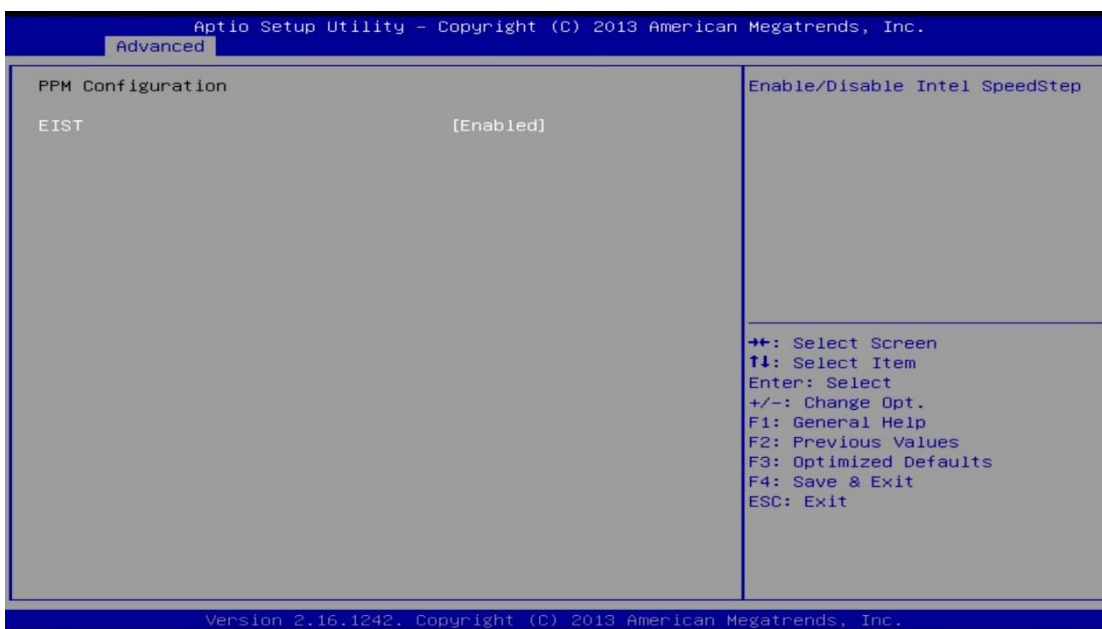

| BIOS Setting | Description                         |
|--------------|-------------------------------------|
| EIST         | Enables / Disables Intel SpeedStep. |

### 4.4.7 IDE Configuration

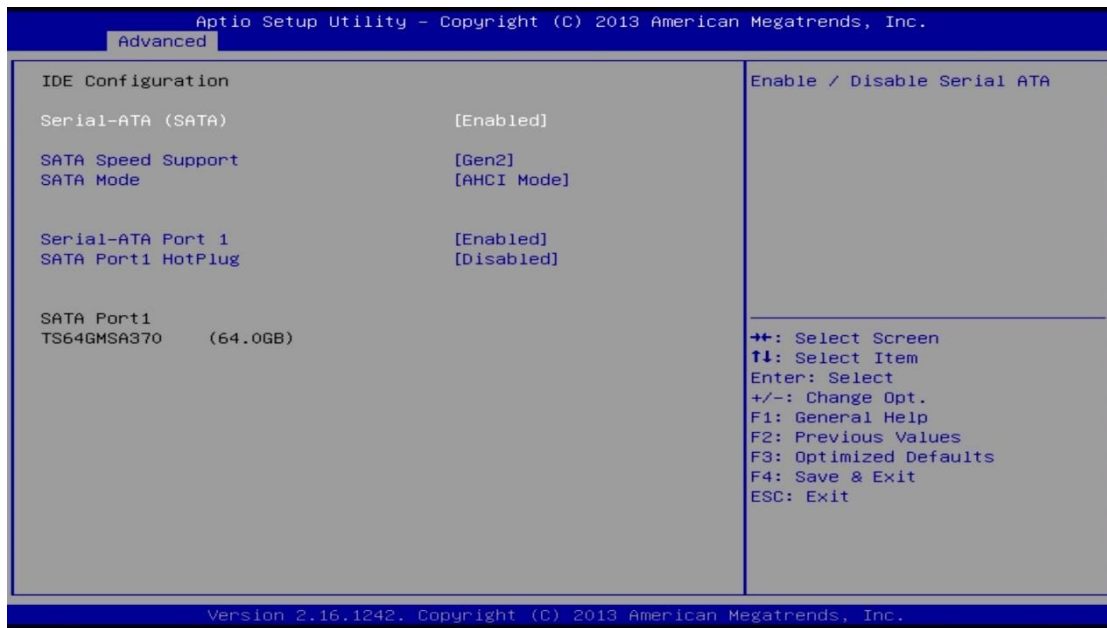

| BIOS Setting        | Description                                 |
|---------------------|---|
| Serial ATA (SATA)   | Enables / Disables Serial ATA.              |
| SATA Speed Support  | Selects SATA speed support as Gen.1 or Gen. |
| SATA Mode           | Selects the SATA mode as IDE or AHCI.       |
| Serial ATA Port 1   | Enables / Disables Serial ATA Port 1.       |
| SATA Port 1 HotPlug | Enables / Disables SATA Port 1 HotPlug.     |

### 4.4.8 USB Configuration

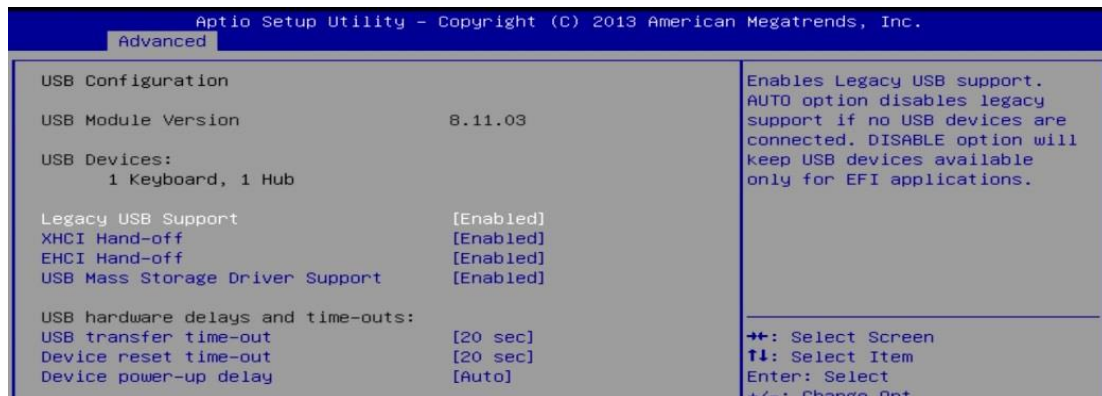

| BIOS Setting                    | Description   |
|---------------------------------|---|
| Legacy USB Support              | <ul style="list-style-type: none"> <li>• <b>Enable:</b> Enables Legacy USB Support.</li> <li>• <b>Auto:</b> Disables legacy support if no USB devices are connected.</li> <li>• <b>Disable:</b> Keeps USB devices available only for EFI applications.</li> </ul> |
| XHCI Hand-off                   | This is a workaround for OSES without XHCI hand-off support. The XHCI ownership change should be claimed by XHCI driver.  |
| EHCI Hand-off                   | This is a workaround for OSES without EHCI hand-off support. The EHCI ownership change should be claimed by EHCI driver.  |
| USB Mass Storage Driver Support | Enables / Disables the support for USB mass storage driver.   |
| Port 60/64 Emulation            | Enables I/O port 60h/64h emulation support. This should be enabled for the complete USB keyboard legacy support for non-USB aware OSES.   |
| USB Transfer time-out           | The time-out value for Control, Bulk, and Interrupt transfers.  |
| Device reset time-out           | Seconds of delaying execution of start unit command to USB mass storage device.   |
| Device power-up delay           | The maximum time the device will take before it properly reports itself to the Host Controller. "Auto" uses default value for a Root port it is 100ms. But for a Hub port, the delay is taken from Hub descriptor.  |

## 4.5 Chipset Settings

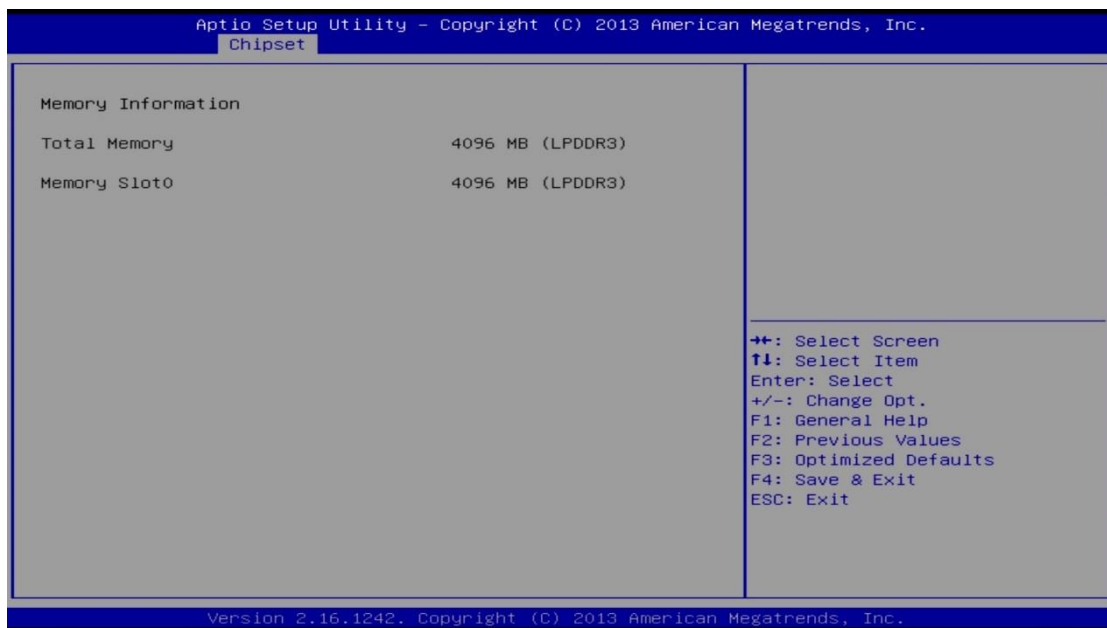
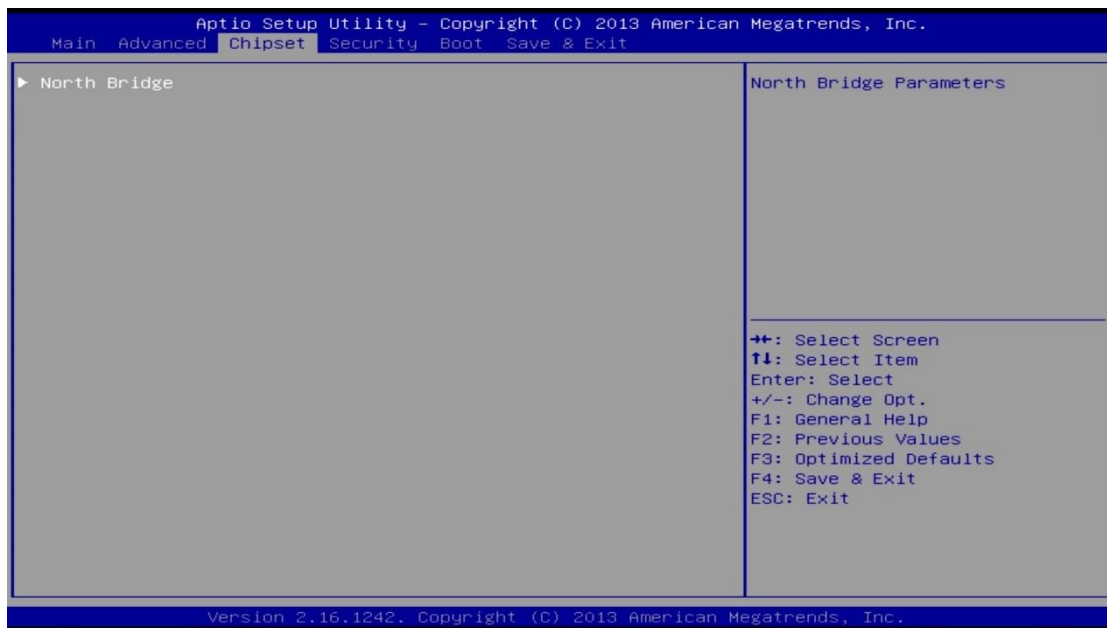

| BIOS Setting | Description                              |
|--------------|--|
| North Bridge | Displays the parameters of North Bridge. |

## 4.6 Security Settings

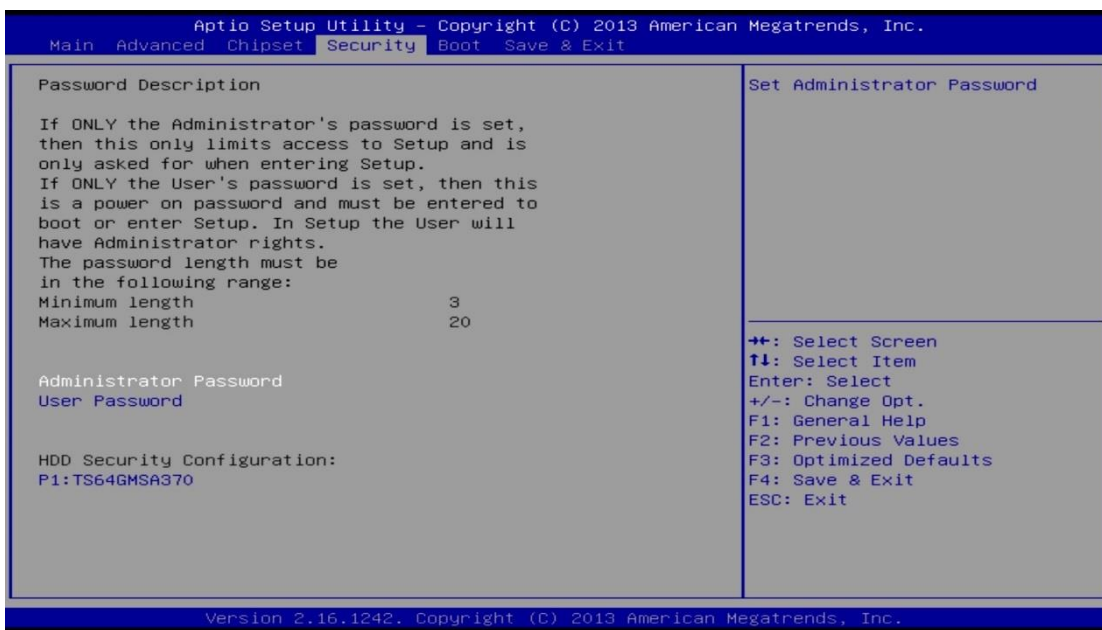

| BIOS Setting           | Description   |
|------------------------|---|
| Administrator Password | Sets an administrator password for the setup utility. |
| User Password          | Sets a user password.                                 |

## 4.7 Boot Settings

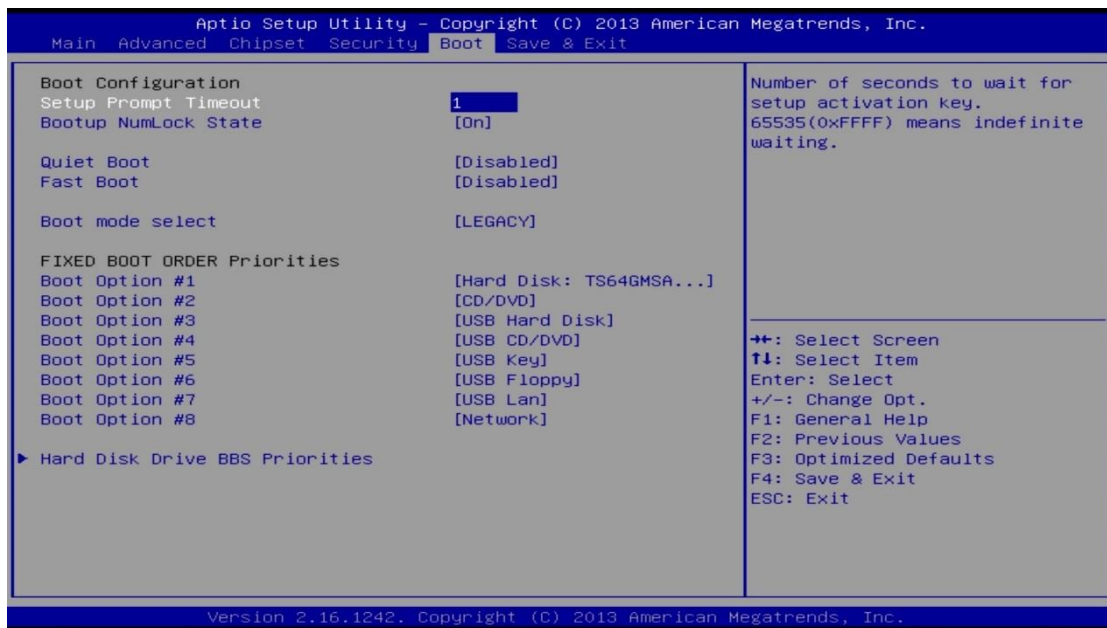

| BIOS Setting                   | Description   |
|--------------------------------|---|
| Setup Prompt Timeout           | Number of seconds to wait for setup activation key.<br>65535 (0xFFFF) means indefinite waiting.   |
| Bootup NumLock State           | Turns on/off the keyboard NumLock state.  |
| Quiet Boot                     | Enables / Disables Quiet Boot option.   |
| Fast Boot                      | Enables / Disables boot with initialization of a minimal set of devices required to launch active boot option. Has not effect for BBS boot options. |
| Boot Mode Select               | Selects a Boot mode, Legacy / UEFI.   |
| Boot Option Priorities         | Sets the system boot order priorities for hard disk, CD/DVD, USB, Network.  |
| Hard Disk Drive BBS Priorities | Specifies the boot device priority sequence from available UEFI hard disk drives.   |

## 4.8 Save & Exit Settings

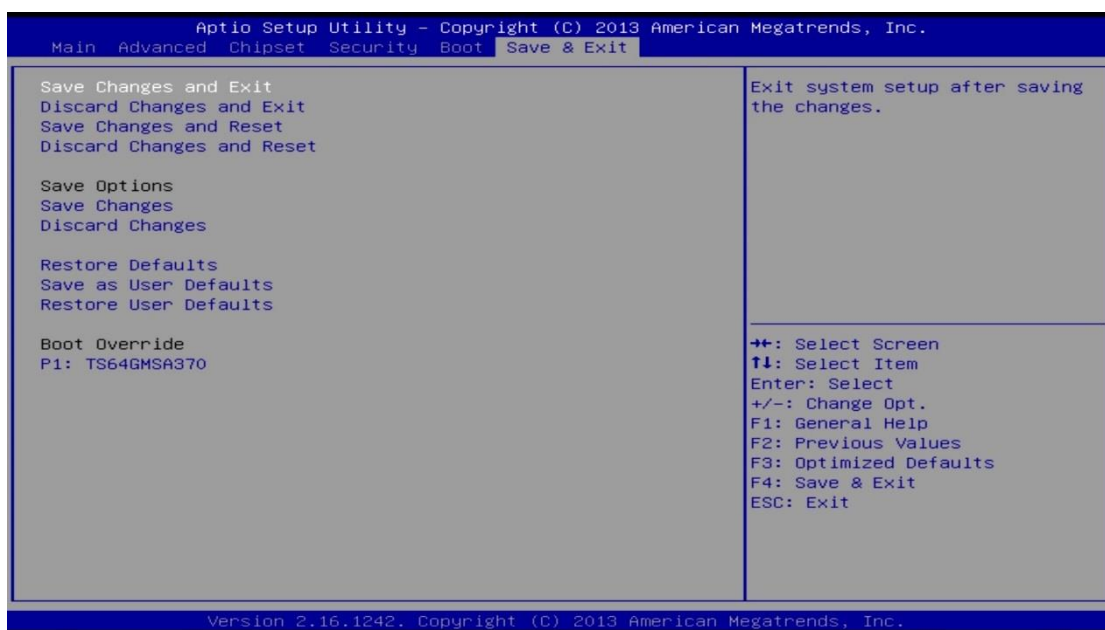

| BIOS Setting              | Description   |
|---------------------------|---|
| Save Changes and Exit     | Exits system setup after saving the changes.                |
| Discard Changes and Exit  | Exits system setup without saving any changes.              |
| Save Changes and Reset    | Resets the system after saving the changes.                 |
| Discard Changes and Reset | Resets system setup without saving any changes.             |
| Save Changes              | Saves changes done so far to any of the setup options.      |
| Discard Changes           | Discards changes done so far to any of the setup options.   |
| Restore Defaults          | Restores / Loads defaults values for all the setup options. |
| Save as User Defaults     | Saves the changes done so far as user defaults.             |
| Restore User Defaults     | Restores the user defaults to all the setup options.        |

## Appendix

This section provides the mapping addresses of peripheral devices and the sample code of watchdog timer configuration.

- I/O Port Address Map
- Interrupt Request Lines (IRQ)
- Watchdog Timer Configuration

## A. I/O Port Address Map

Each peripheral device in the system is assigned a set of I/O port addresses which also becomes the identity of the device. The following table lists the I/O port addresses used.

| Address               | Device Description  |
|-----------------------|---|
| 0x00000A00-0x00000A0F | Motherboard resources   |
| 0x00000290-0x0000029F | Motherboard resources   |
| 0x00000A20-0x00000A2F | Motherboard resources   |
| 0x00000A30-0x00000A3F | Motherboard resources   |
| 0x0000002E-0x0000002F | Motherboard resources   |
| 0x0000004E-0x0000004F | Motherboard resources   |
| 0x00000061-0x00000061 | Motherboard resources   |
| 0x00000063-0x00000063 | Motherboard resources   |
| 0x00000065-0x00000065 | Motherboard resources   |
| 0x00000067-0x00000067 | Motherboard resources   |
| 0x00000070-0x00000070 | Motherboard resources   |
| 0x00000070-0x00000070 | System CMOS/real time clock   |
| 0x00000080-0x0000008F | Motherboard resources   |
| 0x00000092-0x00000092 | Motherboard resources   |
| 0x000000B2-0x000000B3 | Motherboard resources   |
| 0x00000680-0x0000069F | Motherboard resources   |
| 0x00000400-0x0000047F | Motherboard resources   |
| 0x00000500-0x000005FE | Motherboard resources   |
| 0x00000600-0x0000061F | Motherboard resources   |
| 0x0000E000-0x0000E01F | Intel(R) Atom(TM)/Celeron(R)/Pentium(R) Processor Platform Control Unit - SMBus Port - 0F12 |
| 0x0000D000-0x0000DFFF | Intel(R) Atom(TM)/Celeron(R)/Pentium(R) Processor PCI Express - Root Port 1 - 0F48          |
| 0x0000D000-0x0000DFFF | Realtek PCIe GBE Family Controller  |
| 0x0000E070-0x0000E077 | Standard SATA AHCI Controller   |
| 0x0000E060-0x0000E063 | Standard SATA AHCI Controller   |
| 0x0000E050-0x0000E057 | Standard SATA AHCI Controller   |

| Address               | Device Description                |
|-----------------------|-----------------------------------|
| 0x0000E040-0x0000E043 | Standard SATA AHCI Controller     |
| 0x0000E020-0x0000E03F | Standard SATA AHCI Controller     |
| 0x000003F8-0x000003FF | Communications Port (COM1)        |
| 0x000003E8-0x000003EF | Communications Port (COM2)        |
| 0x00000040-0x00000043 | System timer                      |
| 0x00000050-0x00000053 | System timer                      |
| 0x00000000-0x0000006F | PCI Express Root Complex          |
| 0x00000078-0x00000CF7 | PCI Express Root Complex          |
| 0x00000D00-0x0000FFFF | PCI Express Root Complex          |
| 0x0000E080-0x0000E087 | Intel(R) HD Graphics              |
| 0x000003B0-0x000003BB | Intel(R) HD Graphics              |
| 0x000003C0-0x000003DF | Intel(R) HD Graphics              |
| 0x00000020-0x00000021 | Programmable interrupt controller |
| 0x00000024-0x00000025 | Programmable interrupt controller |
| 0x00000028-0x00000029 | Programmable interrupt controller |
| 0x0000002C-0x0000002D | Programmable interrupt controller |
| 0x00000030-0x00000031 | Programmable interrupt controller |
| 0x00000034-0x00000035 | Programmable interrupt controller |
| 0x00000038-0x00000039 | Programmable interrupt controller |
| 0x0000003C-0x0000003D | Programmable interrupt controller |
| 0x000000A0-0x000000A1 | Programmable interrupt controller |
| 0x000000A4-0x000000A5 | Programmable interrupt controller |
| 0x000000A8-0x000000A9 | Programmable interrupt controller |
| 0x000000AC-0x000000AD | Programmable interrupt controller |
| 0x000000B0-0x000000B1 | Programmable interrupt controller |
| 0x000000B4-0x000000B5 | Programmable interrupt controller |
| 0x000000B8-0x000000B9 | Programmable interrupt controller |
| 0x000000BC-0x000000BD | Programmable interrupt controller |
| 0x000004D0-0x000004D1 | Programmable interrupt controller |

## B. Interrupt Request Lines (IRQ)

Peripheral devices use interrupt request lines to notify CPU for the service required. The following table shows the IRQ used by the devices on board.

| Level             | Function  |
|-------------------|---|
| IRQ 3             | Intel(R) Atom(TM)/Celeron(R)/Pentium(R) Processor Platform Control Unit - SMBus Port - 0F12 |
| IRQ 4294967291    | Intel(R) Trusted Execution Engine Interface   |
| IRQ 8             | High precision event timer  |
| IRQ 4294967294    | Standard SATA AHCI Controller   |
| IRQ 4             | Communications Port (COM1)  |
| IRQ 5             | Communications Port (COM2)  |
| IRQ 4294967293    | Realtek PCIe GBE Family Controller  |
| IRQ 0             | System timer  |
| IRQ 23            | Intel(R) Atom(TM)/Celeron(R)/Pentium(R) Processor EHCI USB - 0F34                           |
| IRQ 22            | High Definition Audio Controller  |
| IRQ 54 ~ IRQ 204  | Microsoft ACPI-Compliant System   |
| IRQ 256 ~ IRQ 511 | Microsoft ACPI-Compliant System   |
| IRQ 4294967292    | Intel(R) HD Graphics  |

## C. Watchdog Timer Configuration

The Watchdog Timer (WDT) is used to generate a variety of output signals after a user programmable count. The WDT is suitable for the use in the prevention of system lock-up, such as when software becomes trapped in a deadlock. Under these sorts of circumstances, the timer will count to zero and the selected outputs will be driven.

Under normal circumstance, you will need to restart the WDT at regular intervals before the timer counts to zero.

### 1. Sample Code: The file NCT5523D.H

```
//-----  
//  
// THIS CODE AND INFORMATION IS PROVIDED "AS IS" WITHOUT WARRANTY OF ANY  
// KIND, EITHER EXPRESSED OR IMPLIED, INCLUDING BUT NOT LIMITED TO THE  
// IMPLIED WARRANTIES OF MERCHANTABILITY AND/OR FITNESS FOR A PARTICULAR  
// PURPOSE.  
//  
//-----  
#ifndef __NCT5523D_H  
#define __NCT5523D_H                1  
//-----  
#define  NCT5523D_INDEX_PORT      (NCT5523D_BASE)  
#define  NCT5523D_DATA_PORT      (NCT5523D_BASE+1)  
//-----  
#define  NCT5523D_REG_LD          0x07  
//-----  
#define NCT5523D_UNLOCK           0x87  
#define  NCT5523D_LOCK           0xAA  
//-----  
unsigned int Init_NCT5523D(void);  
void Set_NCT5523D_LD( unsigned char);  
void Set_NCT5523D_Reg( unsigned char, unsigned char);  
unsigned char Get_NCT5523D_Reg( unsigned char);  
//-----  
#endif    //__NCT5523D_H
```

## 2. Sample Code: The file MAIN.CPP

```
//-----
//
// THIS CODE AND INFORMATION IS PROVIDED "AS IS" WITHOUT WARRANTY OF ANY
// KIND, EITHER EXPRESSED OR IMPLIED, INCLUDING BUT NOT LIMITED TO THE
// IMPLIED WARRANTIES OF MERCHANTABILITY AND/OR FITNESS FOR A PARTICULAR
// PURPOSE.
//
//-----
#include <dos.h>
#include <conio.h>
#include <stdio.h>
#include <stdlib.h>
#include "NCT5523D.H"
//-----
int main (void);

void WDTInitial(void);
void WDTEnable(unsigned char);
void WDTDisable(void);

//-----
int main (void)
{
    char SIO;

    SIO = Init_NCT5523D();
    if (SIO == 0)
    {
        printf("Can not detect Nuvoton NCT5523D, program abort.\n");
        return(1);
    }

    WDTInitial();

    WDTEnable(10);

    WDTDisable();

    return 0;
}
//-----
void WDTInitial(void)
{
    unsigned char bBuf;
    Set_NCT5523D_LD(0x08);                //switch to logic device 8
    bBuf = Get_NCT5523D_Reg(0x30);
    bBuf &= (~0x01);
    Set_NCT5523D_Reg(0x30, bBuf);        //Enable WDTO
}
//-----
void WDTEnable(unsigned char NewInterval)
{

```

```
    unsigned char bBuf;

    Set_NCT5523D_LD(0x08);           //switch to logic device 8
    Set_NCT5523D_Reg(0x30, 0x01);    //enable timer

    bBuf = Get_NCT5523D_Reg(0xF0);
    bBuf &= (~0x08);
    Set_NCT5523D_Reg(0xF0, bBuf);    //count mode is second

    Set_NCT5523D_Reg(0xF1, NewInterval); //set timer
}
//-----
void WDTDisable(void)
{
    Set_NCT5523D_LD(0x08);           //switch to logic device 8
    Set_NCT5523D_Reg(0xF1, 0x00);    //clear watchdog timer
    Set_NCT5523D_Reg(0x30, 0x00);    //watchdog disabled
}
//-----
```

### 3. Sample Code: The file NCT5523D.CPP

```

//-----
//
// THIS CODE AND INFORMATION IS PROVIDED "AS IS" WITHOUT WARRANTY OF ANY
// KIND, EITHER EXPRESSED OR IMPLIED, INCLUDING BUT NOT LIMITED TO THE
// IMPLIED WARRANTIES OF MERCHANTABILITY AND/OR FITNESS FOR A PARTICULAR
// PURPOSE.
//
//-----
#include "NCT5523D.H"
#include <dos.h>
//-----
unsigned int NCT5523D_BASE;
void Unlock_NCT5523D (void);
void Lock_NCT5523D (void);
//-----
unsigned int Init_NCT5523D(void)
{
    unsigned int result;
    unsigned char ucDid;

    NCT5523D_BASE = 0x4E;
    result = NCT5523D_BASE;

    ucDid = Get_NCT5523D_Reg(0x20);
    if (ucDid == 0xC4)                //NCT5523D??
    {    goto Init_Finish; }

    NCT5523D_BASE = 0x2E;
    result = NCT5523D_BASE;

    ucDid = Get_NCT5523D_Reg(0x20);
    if (ucDid == 0xC4)                //NCT5523D??
    {    goto Init_Finish; }

    NCT5523D_BASE = 0x00;
    result = NCT5523D_BASE;

Init_Finish:
    return (result);
}
//-----
void Unlock_NCT5523D (void)
{
    outportb(NCT5523D_INDEX_PORT, NCT5523D_UNLOCK);
    outportb(NCT5523D_INDEX_PORT, NCT5523D_UNLOCK);
}
//-----
void Lock_NCT5523D (void)
{
    outportb(NCT5523D_INDEX_PORT, NCT5523D_LOCK);
}
//-----

```

```
void Set_NCT5523D_LD( unsigned char LD)
{
    Unlock_NCT5523D();
    outputb(NCT5523D_INDEX_PORT, NCT5523D_REG_LD);
    outputb(NCT5523D_DATA_PORT, LD);
    Lock_NCT5523D();
}
//-----
void Set_NCT5523D_Reg( unsigned char REG, unsigned char DATA)
{
    Unlock_NCT5523D();
    outputb(NCT5523D_INDEX_PORT, REG);
    outputb(NCT5523D_DATA_PORT, DATA);
    Lock_NCT5523D();
}
//-----
unsigned char Get_NCT5523D_Reg(unsigned char REG)
{
    unsigned char Result;
    Unlock_NCT5523D();
    outputb(NCT5523D_INDEX_PORT, REG);
    Result = inportb(NCT5523D_DATA_PORT);
    Lock_NCT5523D();
    return Result;
}
//-----
```