

SI-626

Digital Signage Player

User's Manual

Version 1.1
(Nov. 2018)



Copyright

© 2018 IBASE Technology, Inc. All rights reserved.

No part of this publication may be reproduced, copied, stored in a retrieval system, translated into any language or transmitted in any form or by any means, electronic, mechanical, photocopying, or otherwise, without the prior written consent of IBASE Technology, Inc. (hereinafter referred to as "IBASE").

Disclaimer

IBASE reserves the right to make changes and improvements to the products described in this document without prior notice. Every effort has been made to ensure the information in the document is correct; however, IBASE does not guarantee this document is error-free. IBASE assumes no liability for incidental or consequential damages arising from misuse or inability to use the product or the information contained herein, and for any infringements of rights of third parties, which may result from its use.

Trademarks

All the trademarks, registrations and brands mentioned herein are used for identification purposes only and may be trademarks and/or registered trademarks of their respective owners.

Compliance

CE

The product described in this manual complies with all applicable European Union (CE) directives if it has a CE marking. For systems to remain CE compliant, only CE-compliant parts may be used. Maintaining CE compliance also requires proper cable and cabling techniques.

FCC

This product has been tested and found to comply with the limits for a Class B device, pursuant to Part 15 of the FCC Rules. These limits are designed to provide reasonable protection against harmful interference in a residential installation. This equipment generates, uses and can radiate radio frequency energy and, if not installed and used in accordance with manufacturer's instructions, may cause harmful interference to radio communications.

WEEE



This product must not be disposed of as normal household waste, in accordance with the EU directive of for waste electrical and electronic equipment (WEEE - 2012/19/EU). Instead, it should be disposed of by returning it to a municipal recycling collection point. Check local regulations for disposal of electronic products.

Green IBASE



This product complies with the current RoHS directives restricting the use of the following substances in concentrations not to exceed 0.1% by weight (1000 ppm) except for cadmium, limited to 0.01% by weight (100 ppm).

- Lead (Pb)
- Mercury (Hg)
- Cadmium (Cd)
- Hexavalent chromium (Cr6+)
- Polybrominated biphenyls (PBB)
- Polybrominated diphenyl ether (PBDE)

Important Safety Information

Carefully read the following safety information before using this device.

Setting up your system:

- Put the device horizontally on a stable and solid surface.
- Do not use this product near water or any heated source.
- Leave plenty of space around the device and do not block the ventilation openings. Never drop or insert any objects of any kind into the openings.
- Use this product in environments with ambient temperatures between 0°C and 45°C.

Care during use:

- Do not place heavy objects on the top of the device.
- Make sure to connect the correct voltage to the device. Failure to supply the correct voltage could damage the unit.
- Do not walk on the power cord or allow anything to rest on it.
- If you use an extension cord, make sure the total ampere rating of all devices plugged into the extension cord does not exceed the extension cord's ampere rating.
- Do not spill water or any other liquids on your device.
- Always unplug the power cord from the wall outlet before cleaning the device.
- Only use neutral cleaning agents to clean the device.
- Vacuum dust and particles from the vents by using a computer vacuum cleaner.

Product Disassembly

Do not try to repair, disassemble, or make modifications to the device. Doing so will void the warranty and may result in damage to the product or personal injury.



CAUTION

There is a danger of explosion if the lithium-ion battery is replaced with an incorrect battery. Replace only with the same or equivalent type recommended by the manufacturer. Dispose of used batteries by observing local regulations.

Warranty Policy

- **IBASE standard products:**

24-month (2-year) warranty from the date of shipment. If the date of shipment cannot be ascertained, the product serial numbers can be used to determine the approximate shipping date.
- **3rd-party parts:**

12-month (1-year) warranty from delivery for 3rd-party parts that are not manufactured by IBASE, such as CPU, CPU cooler, memory, storage devices, power adaptor, display panel and touch screen.
- * PRODUCTS, HOWEVER, THAT FAIL DUE TO MISUSE, ACCIDENT, IMPROPER INSTALLATION OR UNAUTHORIZED REPAIR SHALL BE TREATED AS OUT OF WARRANTY AND CUSTOMERS SHALL BE BILLED FOR REPAIR AND SHIPPING CHARGES.

Technical Support & Services

1. Visit the IBASE website at www.ibase.com.tw to find the latest information about the product.
2. If you encounter any technical problems and require assistance from your distributor or sales representative, please prepare and send the following information:
 - Product model name
 - Product serial number
 - Detailed description of the problem
 - Error messages in text or screenshots if any
 - The arrangement of the peripherals
 - Software used (such as OS and application software)
3. If repair service is required, please download the RMA form at <http://www.ibase.com.tw/english/Supports/RMAService/>. Fill out the form and contact your distributor or sales representative.

Table of Contents

Compliance	iii
Important Safety Information	iv
CAUTION	iv
Warranty Policy	v
Technical Support & Services	v
Chapter 1 General Information	1
1.1 Introduction	2
1.2 Features.....	2
1.3 Packing List	3
1.4 Optional Accessories	3
1.5 Specifications.....	4
1.6 I/O View	6
1.7 Dimensions	7
Chapter 2 Hardware Installation & Motherboard Information	8
2.1 Installations.....	9
2.1.1 Memory Installation / Replacement.....	9
2.1.2 Mini-PCIe & M.2 Cards Installation	10
2.1.3 WiFi / 3G / 4G Antenna Installation.....	10
2.1.4 HDMI Cable Holder Installation.....	11
2.1.5 Mounting Installation.....	12
2.1.6 Pin Assignment for Power Input Connector	13
2.1.7 Pin Assignment for COM1 & COM2 Serial Ports.....	13
2.2 Setting the Jumpers	15
2.2.1 How to Set Jumpers	15
2.3 Jumper & Connector Locations on Motherboard	16
2.4 22Jumper & Connectors Quick Reference	17
2.4.1 Clearing CMOS Data (JP2).....	18
2.4.2 DC Power Input (CN17).....	18
2.4.3 CPU Fan Power Connector (J1, J2, J3)	19
2.4.4 USB 2.0 Ports Header (J7).....	19
2.4.5 System Function Connector (J18).....	20
2.4.6 Digital I/O Connector (J17).....	20
2.4.7 Battery Connector (JBAT1)	21

Chapter 3	Driver Installation	22
3.1	Introduction	23
3.2	Intel® Chipset Software Installation Utility	23
3.3	Intel® Graphics Driver Installation	25
3.4	HD Audio Driver Installation	27
3.5	LAN Driver Installation	28
3.6	Intel® Management Engine Components Drivers Installation	29
Chapter 4	BIOS Setup	30
4.1	Introduction	31
4.2	BIOS Setup	31
4.3	Main Settings	32
4.4	Advanced Settings	32
4.4.1	CPU Configuration	33
4.4.2	Power & Performance	34
4.4.3	PCH-FW Configuration	35
4.4.4	ACPI Settings	35
4.4.5	iSmart Controller	36
4.4.6	F81846 Super IO Configuration	37
4.4.7	Hardware Monitor	38
4.4.8	Network Stack Configuration	39
4.4.9	CSM Configuration	40
4.4.10	NVMe Configuration	41
4.5	Chipset Settings	42
4.5.1	System Agent Configuration	42
4.5.2	PCH-IO Configuration	43
4.6	Security Settings	44
4.7	Boot Settings	45
4.8	Save & Exit Settings	46
Appendix	47
A.	AMD Eyefinity Multiple Displays Configuration	48
A.1	Setting Up AMD Eyefinity Using Quick Setup	48
A.2	Customizing AMD Eyefinity Using Try Advanced Setup	52
A.3	Video Wall Layouts Applicable to SI-626	58
B.	I/O Port Address Map	60
C.	Interrupt Request Lines (IRQ)	63
D.	Watchdog Timer Configuration	64

Chapter 1

General Information

The information provided in this chapter includes:

- Features
- Packing List
- Specifications
- Optional Accessories
- Overview
- Dimensions

1.1 Introduction

The SI-626 is powered by Intel® 7th / 6th Generation mobile processors. It supports three display outputs for HDMI high definition video playback and iSmart energy-saving features such as power on/off scheduling and power resume function. The device operates in environments with temperatures ranging from 0°C to 45°C.



1.2 Features

- Slim and segregated ventilation design
- iSmart - for EuP/ErP power saving, auto-scheduling and power resumption
- 6 x HDMI1.4b with independent audio output
- Built-in hardware EDID emulation function
- 7th / 6th Generation Intel® Core™ mobile processor
- 2 x DDR4-2133 SO-DIMM, dual channel, Max. 32 GB
- Flexible VW display configuration setting
- 1 x Mini PCIe (full-size) for Wi-Fi, Bluetooth, 4G LTE or capture card options
- 1 x M.2 E2230 for Wi-Fi, Bluetooth, 4G LTE options
- 1 x M.2 M2280 for storage
- 2 x RS232 serial ports

1.3 Packing List

If you buy a barebone SI-626, your product package should include the items listed below. If any of the items below is missing, contact the distributor or the dealer from whom you have purchased the product.

Drivers and this user manual are downloadable from our website.

- SI-626 Digital Signage Player x 1
- Power Adaptor x 1
- Power Cord x 1
- HDMI Cable Holder x 1
- Screws with Washer for HDMI Cable Holder (M3 x 6 mm) x 2

1.4 Optional Accessories

IBASE provides optional accessories as listed below. Please contact us or your dealer if you would like to order any item(s).

- VESA Kit
 - Including:
 - Mounting Bracket x 1
 - Round Head Screw (M6 x 35 mm) x 4
 - Pan Head Screw (M4 x 8 mm) x 4

1.5 Specifications

Product	SI-626
System	
Mainboard	MBD626
Operating System	<ul style="list-style-type: none"> • Windows 10 Enterprise (64-bit) • Windows 7 (64-bit), • Linux Ubuntu (64-bit)
CPU	Intel® 7 th / 6 th Gen. Core™ mobile processor
Chipset	Intel® HM170 / QM170
Memory	2 x DDR4 SO-DIMM 2133 MHz, dual channel, expandable to 32GB
Graphics	AMD Radeon™ E8860 Graphics
Network	2 x Realtek RTL8111G GbE LAN
Super I/O	Fintek F81846AD
Storage	1 x 2.5" SATA SSD / HDD
Power Requirement	12V DC-in
Power Supply	150W power adaptor
Watchdog	Watchdog Timer 256 segments, 0, 1, 2...255 sec/min
iSmart	Yes
Chassis	Aluminum and SGCC, black & white
Mounting	VESA mount 75 x 75 mm / 100 x 100 mm Wall mount/TV Mount 200 x 100 mm
Dimensions (W x H x D)	290 x 29.9 x 222 mm (11.41" x 1.17" x 8.74")
Net Weight	2.1 kg (4.63 lb)
Compliance	CE, FCC class B, cULus & CCC
I/O Ports	
HDMI	6 x HDMI 1.4 with hardware EDID emulation
LAN	2 x GbE RJ45 LAN port
Serial	<ul style="list-style-type: none"> • 2 x RJ50 for RS-232 serial port
USB	4 x USB 3.0
Audio Jack	<ul style="list-style-type: none"> • 1 x Line-Out • 1 x Mic-In
Power Jack	1 x DC-In power jack

SIM	1 x SIM card socket (on board)
Expansion	<ul style="list-style-type: none"> • 1 x M.2 E2230 for WiFi / BT / 4G LTE options • 1 x M.2 M2280 for storage • 1 x full size Mini-PCIe (x1) for WiFi / BT / TV tuner / 4G LTE options
Environment	
Temperature	<ul style="list-style-type: none"> • Operating: 0°C ~ 45°C (32°F ~ 113°F) • Storage: -20°C ~ 80°C (-4°F ~ 176°F)
Relative Humidity	5 ~ 90% at 45°C (non-condensing)
Vibration	SSD: 5 grms / 5 ~ 500 Hz, random operation

All specifications are subject to change without prior notice.

Note: The product performance relies on the system functioning as a whole. The level of CPU/APU/GPU processor, the interaction among the processor and the memory and storage bandwidth, or the functionality of the digital signage application software may affect the product performance.

1.6 I/O View

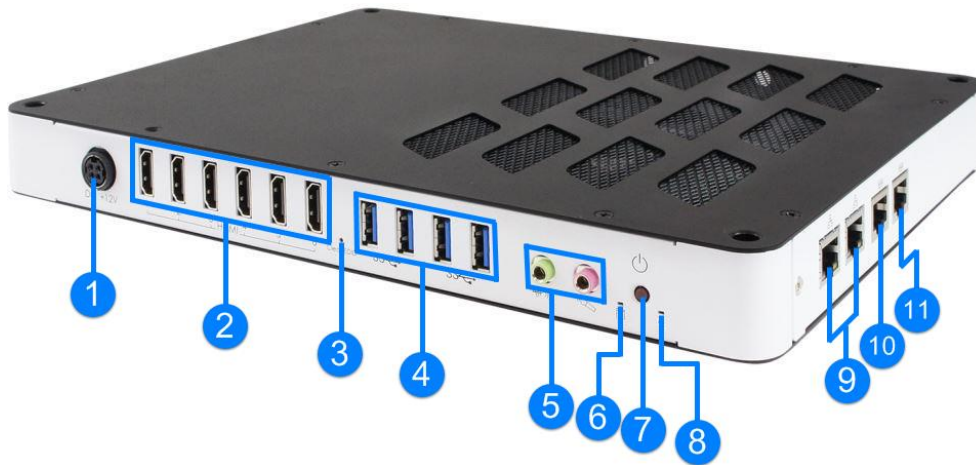

No.	Name	No.	Name
1	DC Power Input	7	Power Button
2	HDMI Ports	8	LED Indicator for Power
3	EDID Button*	9	LAN Port
4	USB 3.0 Ports	10	COM1 RS-232/422/485 Port
5	Audio Jacks (From left to right: Line-Out, Mic-In)	11	COM2 RS-232 Port
6	LED Indicator for HDD		

* Be sure to press the EDID Button to acquire or change the EDID data when the connected display/monitor cannot be recognized, or the displayed image does not fit the screen.

1.7 Dimensions

Unit: mm

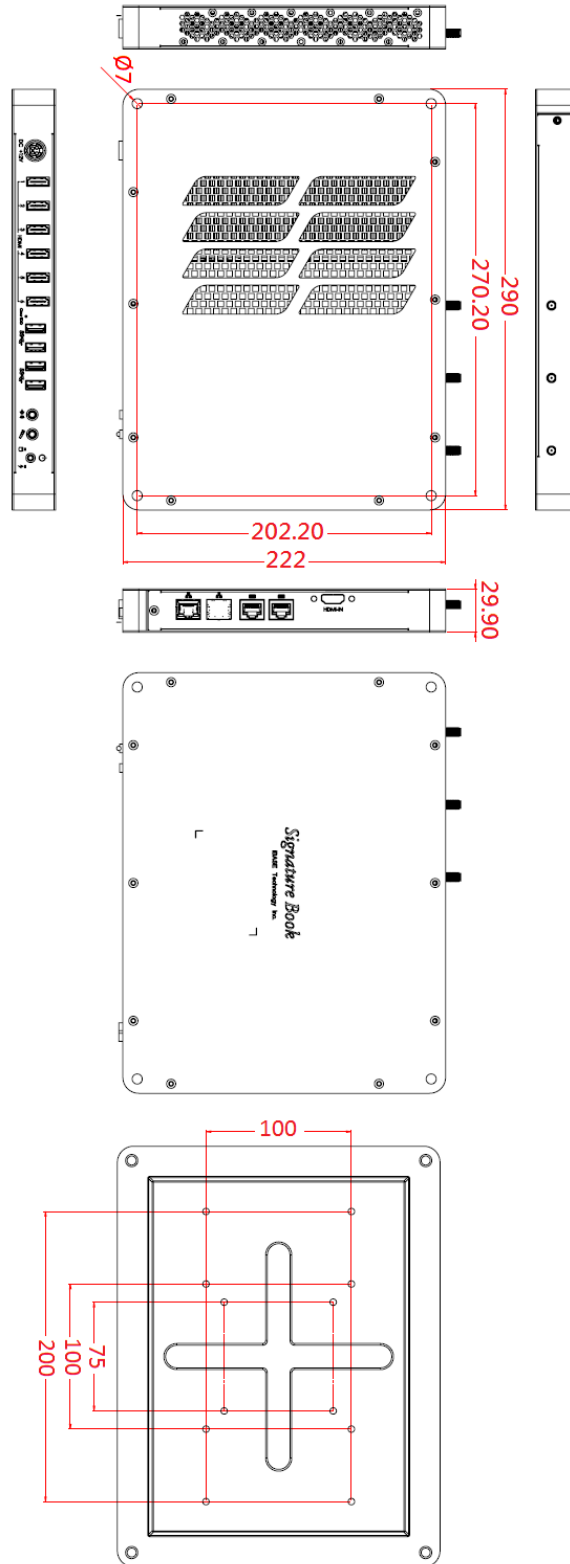

Chapter 2

Hardware Installation & Motherboard Information

This section contains general information about:

- Installations
- Jumper and connectors

2.1 Installations

Before installing any card or module into the device, remove the 10 screws shown in the picture below to remove the cover.

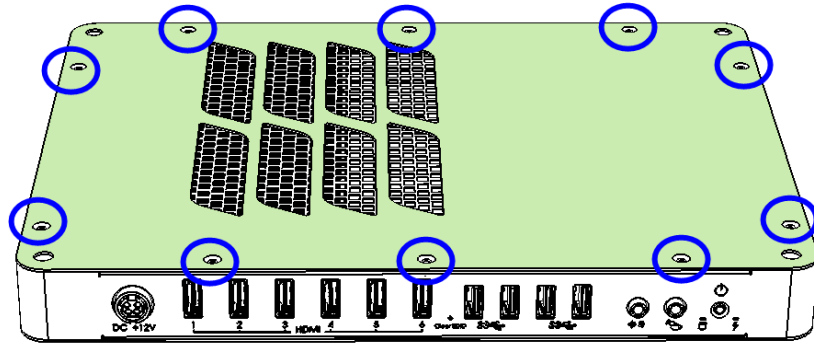

2.1.1 Memory Installation / Replacement

To install or replace modules, locate the memory slot on the board and perform the following steps:

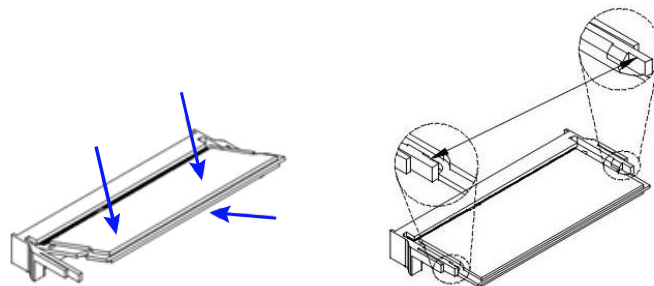

1. Align the key of the memory module with that on the memory slot and insert the module slantwise.
2. Gently push the module in an upright position until the clips of the slot close to hold the module in place when the module touches the bottom of the slot.

To remove a module, use your fingers to press the clips outwards until the module pops up. Grab the module gently and pull it out of the slot.

2.1.2 Mini-PCle & M.2 Cards Installation

1. Align the mini-PCle card's bus connector with the mini-PCle slot, and insert the card slantwise.

(Insert M.2 cards by using the same method.)

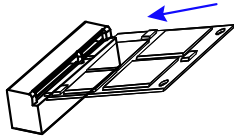

2. Push the mini PCle card downwards as shown in the picture, and fix it with a screw.

(Fix M.2 cards by using the same method.)

Mini PCle:

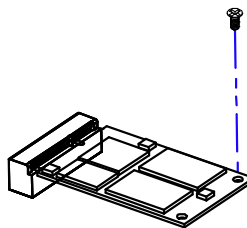
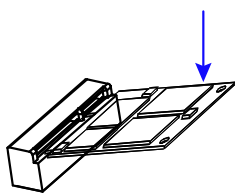

M.2:

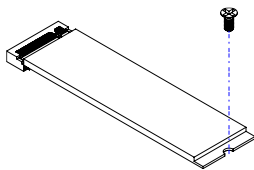

2.1.3 WiFi / 3G / 4G Antenna Installation

Insert the WiFi / 3G / 4G antenna extension cable through the antenna hole of the front I/O cover and fasten the antenna as shown below. Then apply adhesive around the hex nut behind the front I/O cover to prevent the extension cable from falling off if the cable becomes loose.

1. Fasten the hex nut and the washer. Then install the antenna.
2. Apply adhesive around here.



Info: The diameter of the nut is around 6.35 mm (0.25"-36UNC).

2.1.4 HDMI Cable Holder Installation

An HDMI cable holder comes with the product package. After you have plugged the HDMI cables, you can use the holder to prevent the cables from coming loose. Align the holder to the HDMI ports and secure it with the supplied two round-head screws with washer as shown below.

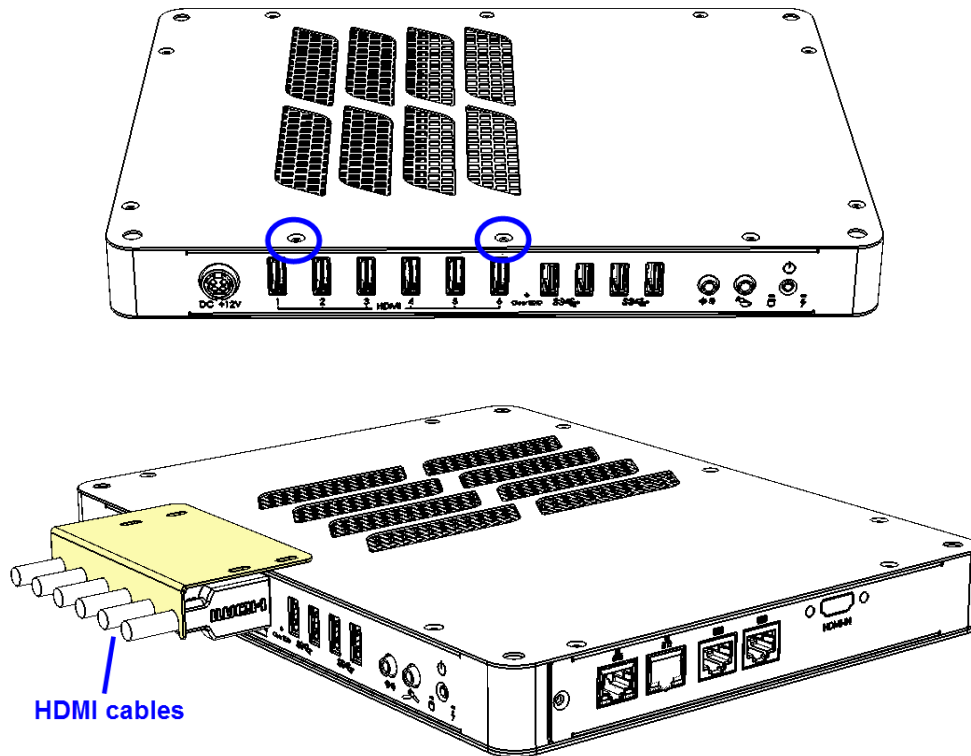

2.1.5 Mounting Installation

Note: Mounting plate is optional and purchasable from IBASE.

Requirements

Before mounting the system, ensure that you have enough room for the power adaptor and signal cable routing, and have good ventilation for the power adaptor. The method of mounting must be able to support weight of the device plus the weight of the suspending cables attached to the system.

The device with the optional mounting plate is shown as the figure below. Prepare at least 4 screws (M3) to install the device on the wall.

- VESA 75 x 75 mm
- VESA 100 x 100mm
- Wall Mount / TV Mount: 200 x 100 mm

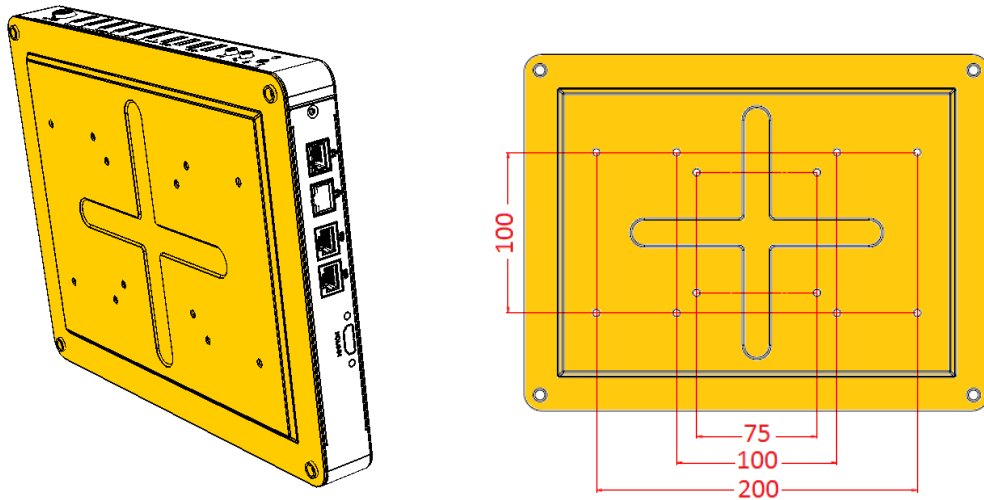

2.1.6 Pin Assignment for Power Input Connector

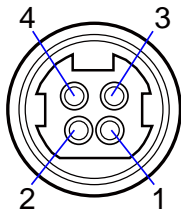

Pin	Signal	Pin	Signal
1	Ground	3	+12V
2	Ground	4	+12V

2.1.7 Pin Assignment for COM1 & COM2 Serial Ports



COM1 RS-232/422/485 port:

Pin	Signal Name		
	RS-232	RS-422	RS-485
1	DSR	NC	NC
2	Ground	Ground	Ground
3	Ground	Ground	Ground
4	TX	RX+	NC
5	RX	TX+	DATA+
6	DCD	TX-	DATA-
7	DTR	RX-	NC
8	CTS	NC	NC
9	RTS	NC	NC
10	RI	NC	NC

COM2 RS-232 port:

Pin	Signal Name	Pin	Signal Name
1	DSR (Data set ready)	6	DCD (Data carrier detect)
2	Ground	7	DTR (Data terminal ready)
3	Ground	8	CTS (Clear to send)
4	TX (Transmit)	9	RTS (Request to send)
5	RX (Receive)	10	RI (Ring indicator)

2.2 Setting the Jumpers

Configure your device by using jumpers to enable the features that you need based on your applications. Contact your supplier if you have doubts about the best configuration for your use.

2.2.1 How to Set Jumpers

Jumpers are short-length conductors consisting of several metal pins with a base mounted on the circuit board. Jumper caps are placed (or removed) on the pins to enable or disable functions or features. If a jumper has 3 pins, you can connect Pin 1 with Pin 2 or Pin 2 with Pin 3 by shorting the jumper.

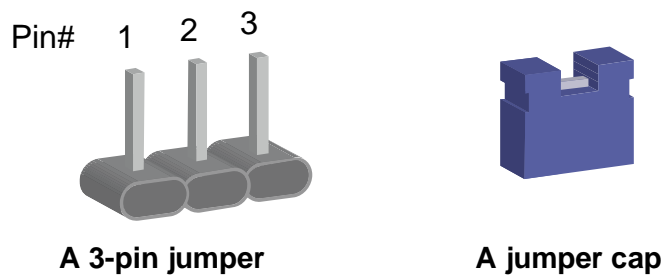

Refer to the illustration below to set jumpers.

Pin closed	Oblique view	Illustration in the manual
Open		
1-2		
2-3		

When two pins of a jumper are encased in a jumper cap, this jumper is **closed**, i.e. turned **On**.

When a jumper cap is removed from two jumper pins, this jumper is **open**, i.e. turned **Off**.

2.3 Jumper & Connector Locations on Motherboard

Motherboard: MBD626

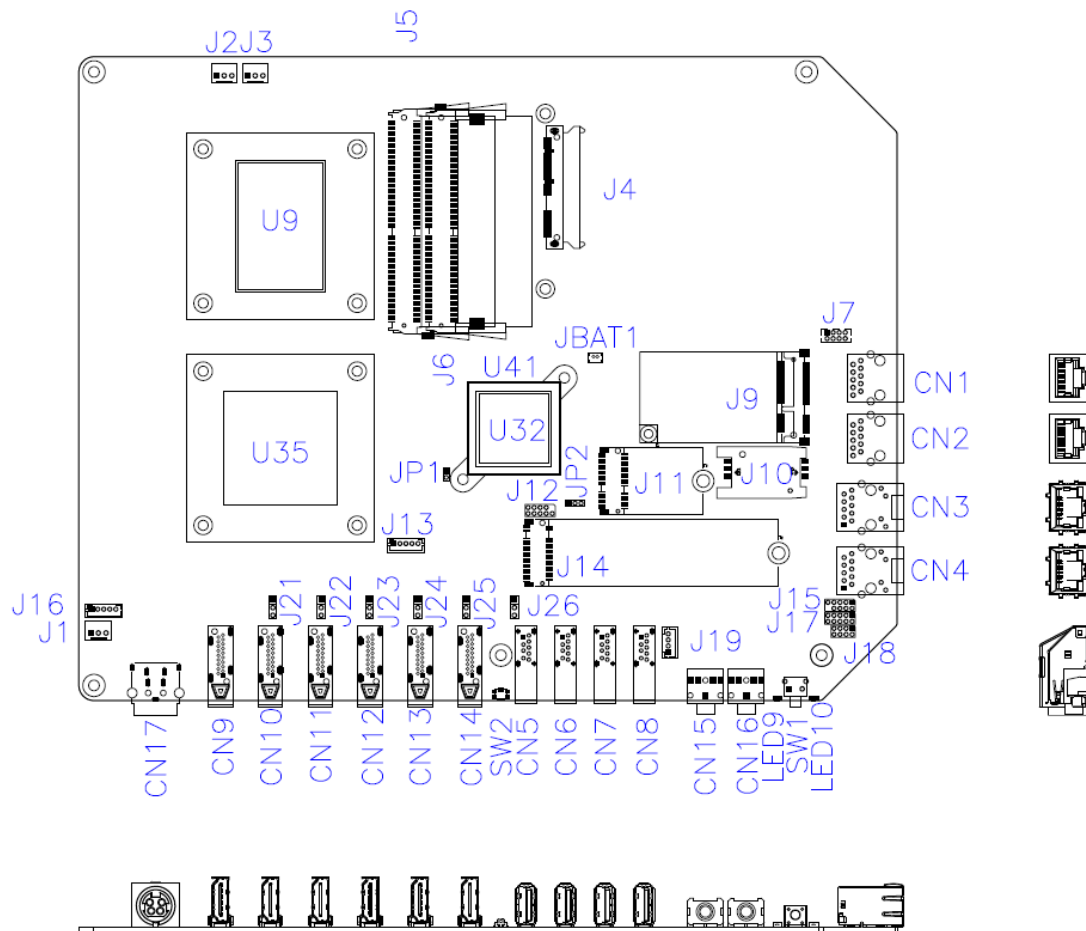

2.4 Jumper & Connectors Quick Reference

Jumper:

Function	Connector Name	Page
Clearing CMOS Data	JP2	19

Connectors:

Function	Connector Name	Page
DC Power Input	CN17	19
CPU Fan Power	J1, J2, J3	20
USB 2.0 Ports Header	J7	21
System Function	J18	22
Digital I/O Header	J17	22
Battery Connector	JBAT1	21
NGFF M.2 E2230 Slot	J11	--
NGFF M.2 M2280 Slot	J14	--
SIM Card Socket	J10	--
Mini-PCIe Slot	J9	--
DDR4 SO-DIMM Slot	J5, J6	--
SSD SATA Connector	J4	--
EDID Button*	SW2	--
HDMI Port	CN9, CN10, CN11, CN12, CN13, CN14	--
USB 3.0 Port	CN5, CN6, CN7, CN8	--
GbE LAN Port	CN3, CN4	--
COM2 RS-232 Port ^[1]	CN1	--
COM1 RS-232/422/485 Port ^[1]	CN2	--
Audio Jack	CN15 (Line-In), CN16 (Mic-In)	--
Power Button	SW1	--
LED Indicators	LED9 (for HDD), LED10 (for power status)	--
Factory Use Only	J12, J13, J15, J16, J19, J21, J22, J23, J24, J25, J26, JP1	--

* Be sure to press the EDID Button to acquire or change the EDID data when the connected display/monitor cannot be recognized, or the displayed image does not fit the screen.

[1]: Refer to the section 2.1.7 Pin Assignment for COM1 & COM2 Serial Ports for the pin assignments.

2.4.1 Clearing CMOS Data (JP2)

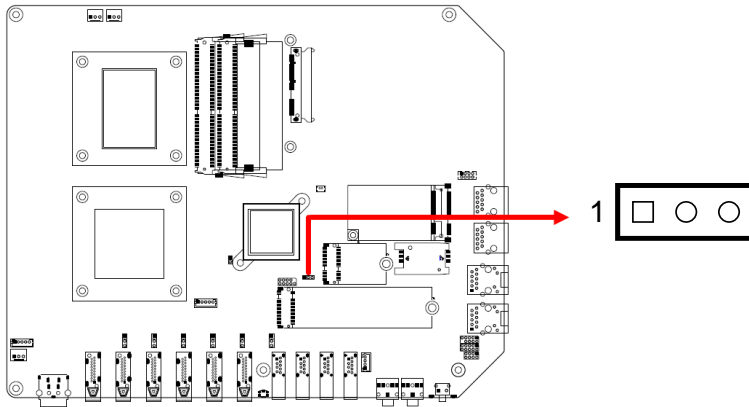

Function	Pin closed	Illustration
Normal (default)	1-2	1
Clear CMOS	2-3	1

2.4.2 DC Power Input (CN17)

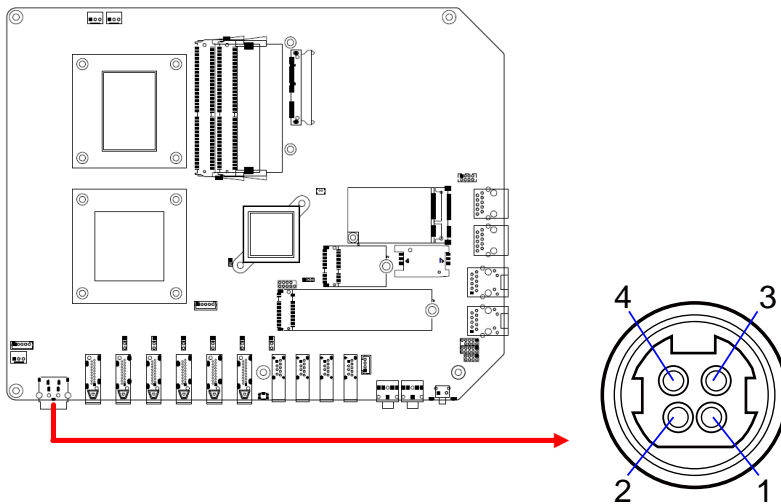

Pin	Signal	Pin	Signal
1	Ground	3	+12V
2	Ground	4	+12V

2.4.3 CPU Fan Power Connector (J1, J2, J3)

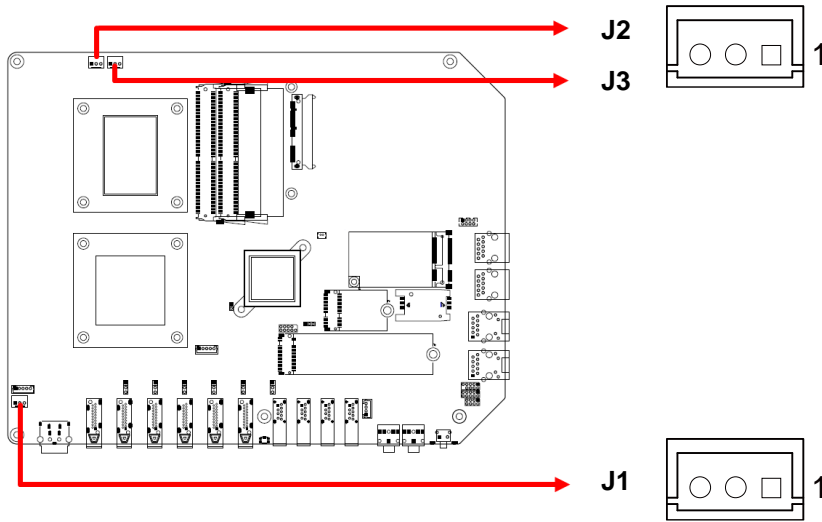

Pin	Signal Name	Pin	Signal Name
1	Ground	3	Rotation detection
2	+12V		

2.4.4 USB 2.0 Ports Header (J7)

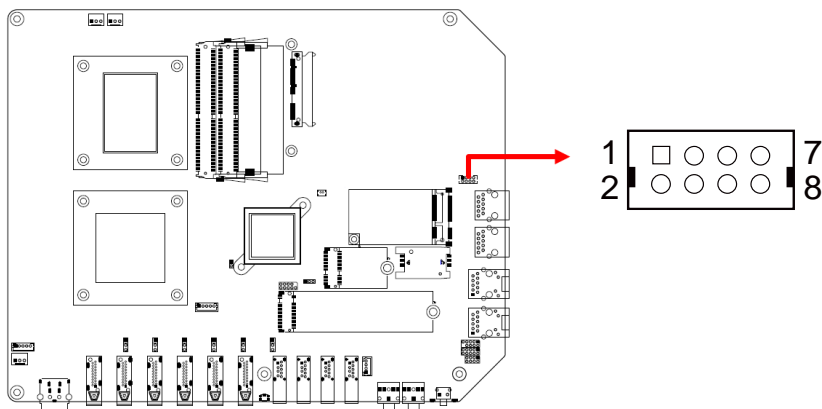

Pin	Signal Name	Pin	Signal Name
1	+5V	2	+5V
3	Data-	4	Data-
5	Data+	6	Data+
7	Ground	8	Ground

2.4.5 System Function Connector (J18)

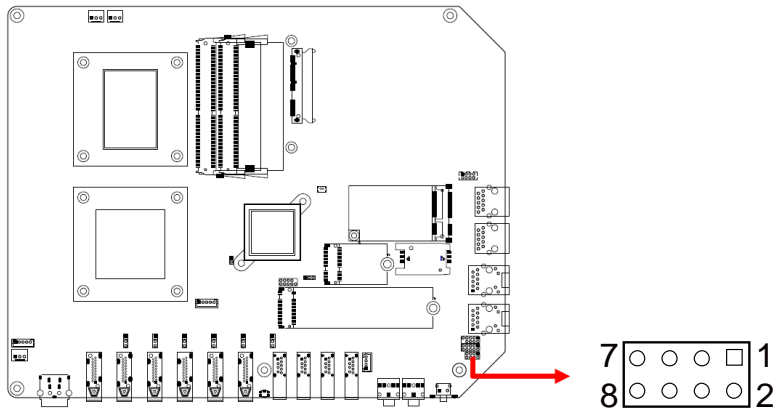

Pin	Signal Name	Pin	Signal Name
1	Power BTN	2	Power BTN
3	HDD LED+	4	HDD LED-
5	Reset BTN	6	Reset BTN
7	+5V	8	+5VSB

2.4.6 Digital I/O Connector (J17)

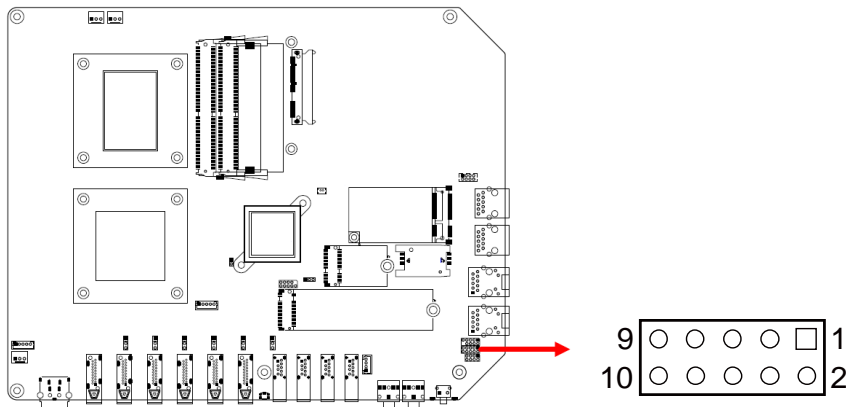

Pin	Signal Name	Pin	Signal Name
1	Ground	2	+5V
3	OUT3	4	OUT1
5	OUT2	6	OUT0
7	IN3	8	IN1
9	IN2	10	IN0

2.4.7 Battery Connector (JBAT1)

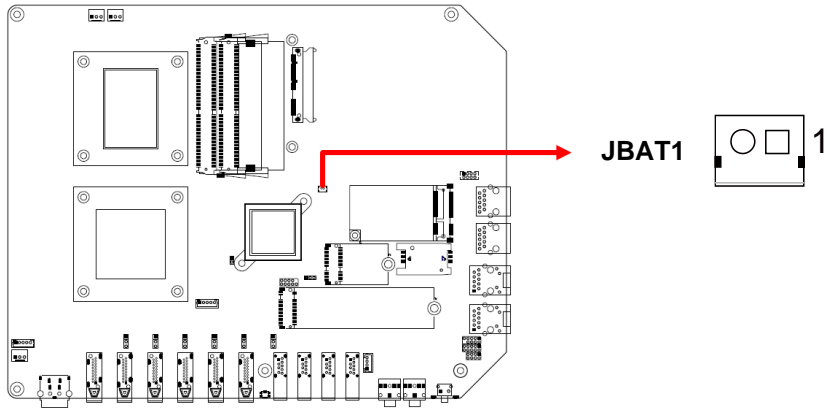

Pin	Signal Name	Pin	Signal Name
1	Battery+	2	Ground

Chapter 3

Driver Installation

The information provided in this chapter includes:

- Intel® Chipset Software Installation Utility
- HD Audio Driver Installation
- LAN Driver Installation
- Intel® Management Engine Driver Installation
- USB 3.1 Driver Installation

3.1 Introduction

This section describes the installation procedures for software drivers. The software drivers are available on IBASE website www.ibase.com.tw. Go to the download page of the product. Copy the compressed drivers file to your computer. Double click the file to decompress it. Run “CDGuide” to go to the main drivers page.

Note: After installing your Windows operating system, you must install the Intel® Chipset Software Installation Utility first before proceeding with the drivers installation.

3.2 Intel® Chipset Software Installation Utility

The Intel® Chipset drivers should be installed first before the software drivers to install INF files for Plug & Play function for the chipset components. Follow the instructions below to complete the installation.

1. Run the **Setup.exe** file.
2. When the *Welcome* screen to the Intel® Chipset Device Software appears, click **Next** to continue.



3. Accept the license agreement and proceed with the installation process.

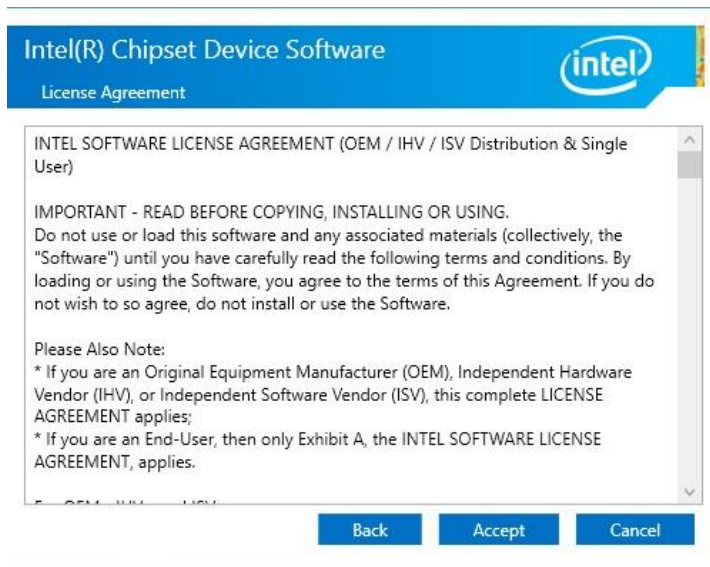

4. On the *Readme File Information* screen, click **Install**.

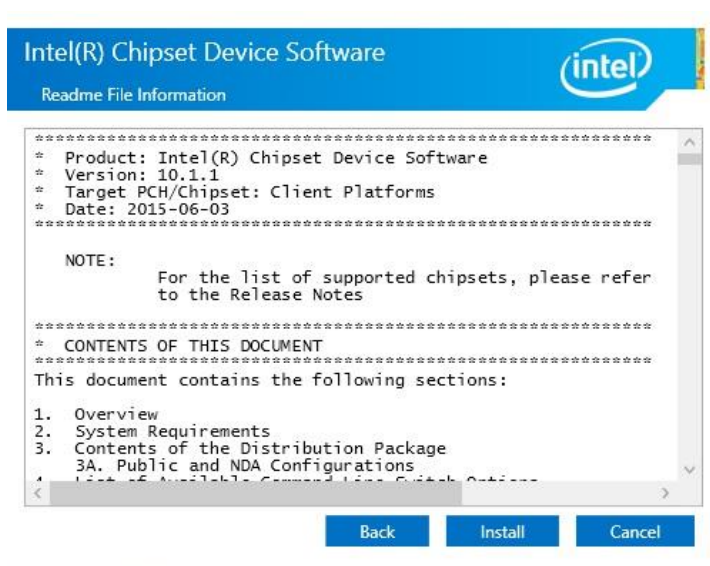

5. Installation is now complete. Restart the system for changes to take effect.

3.3 Intel® Graphics Driver Installation

1. Run the **Setup.exe** file.
2. When the *Welcome* screen appears, click **Next** to continue.

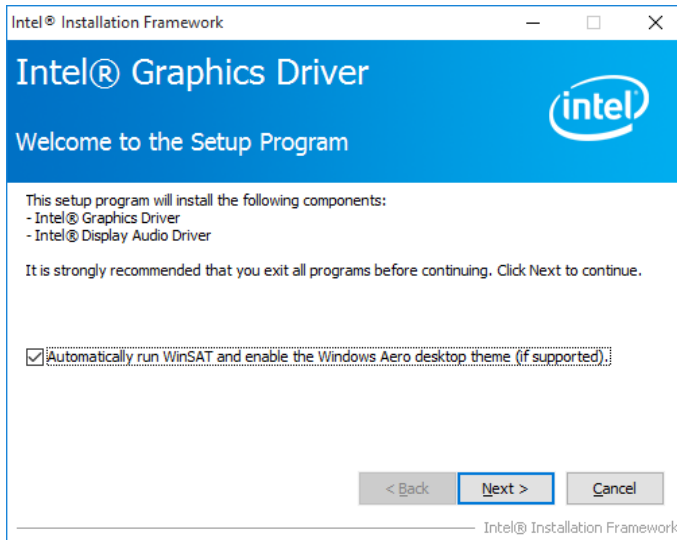

3. Click **Yes** to agree with the license agreement and continue the installation.

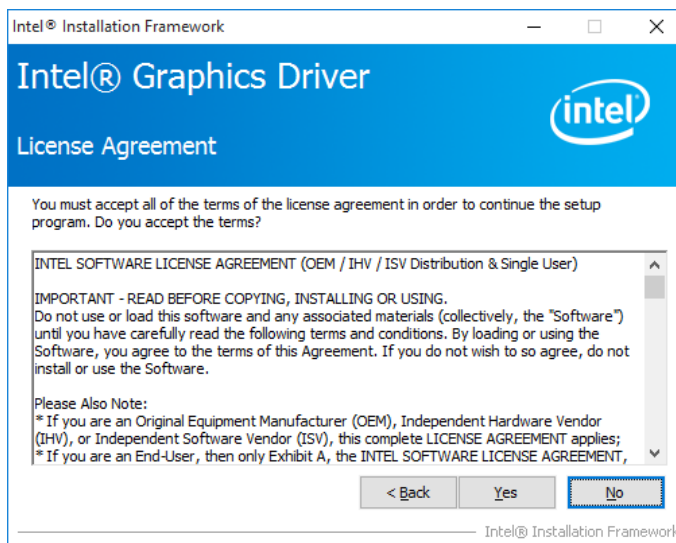

4. On the *Readme File Information* and *Setup Progress* screen, click **Next**.

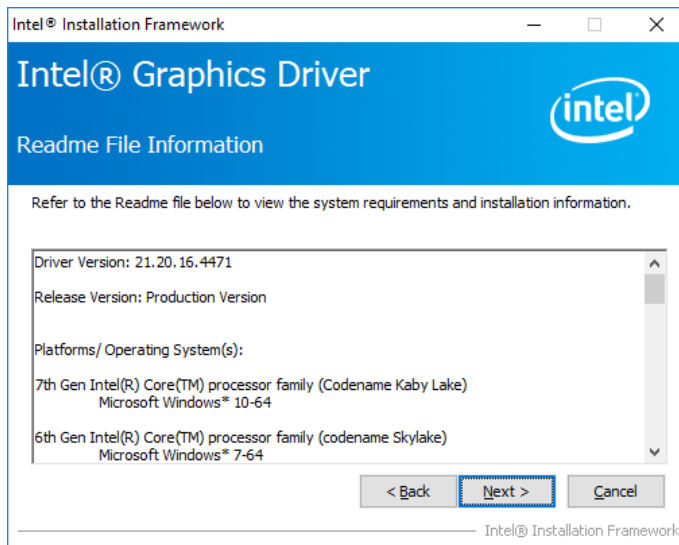

5. Choose a destination folder for installation.
6. Installation is now complete. Restart the system for changes to take effect.

3.4 HD Audio Driver Installation

1. Run the **Setup.exe** file and the wizard starts.

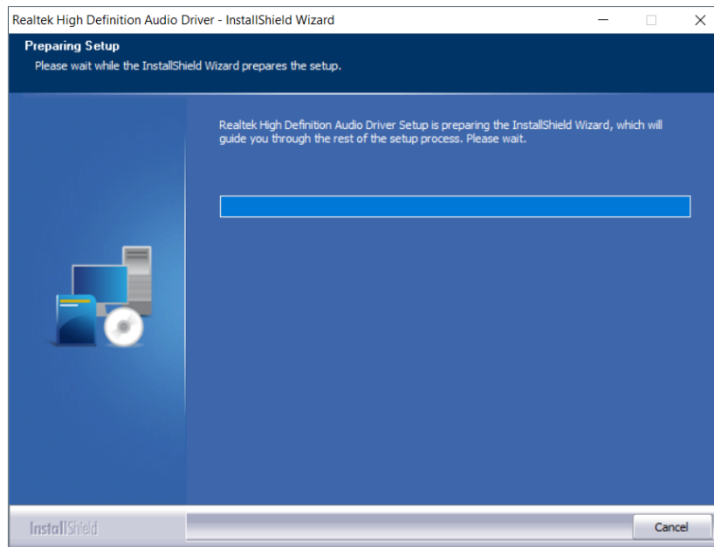

2. On the *Welcome* screen of the InstallShield Wizard, click **Next** to start installing the audio driver on your system.

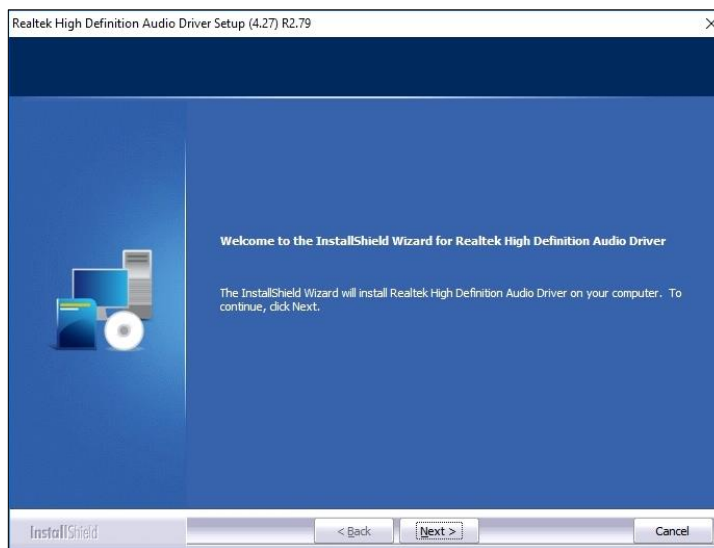

3. Installation is now complete. Restart the system for changes to take effect.

3.5 LAN Driver Installation

1. Run the **Setup.exe** file.
2. On the *Welcome* screen of the InstallShield Wizard, click **Next** to continue.

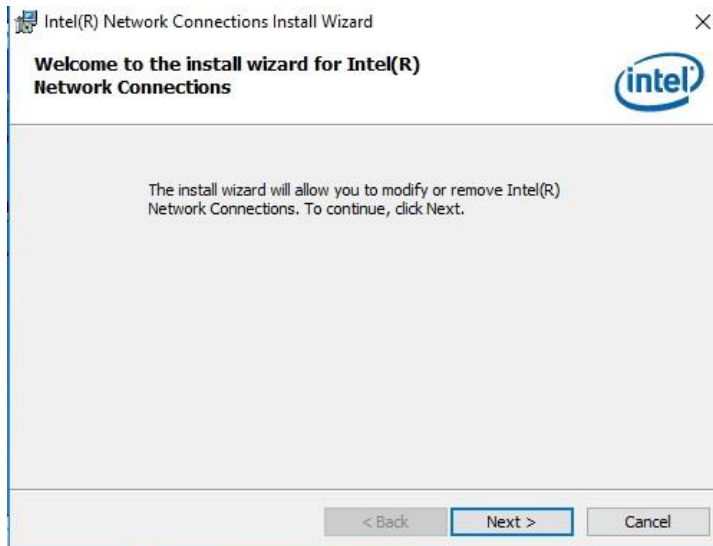

3. Accept the license agreement and click **Next**.
4. On the *Setup Options* screen, tick the checkbox to select the desired driver(s) and click **Next**.

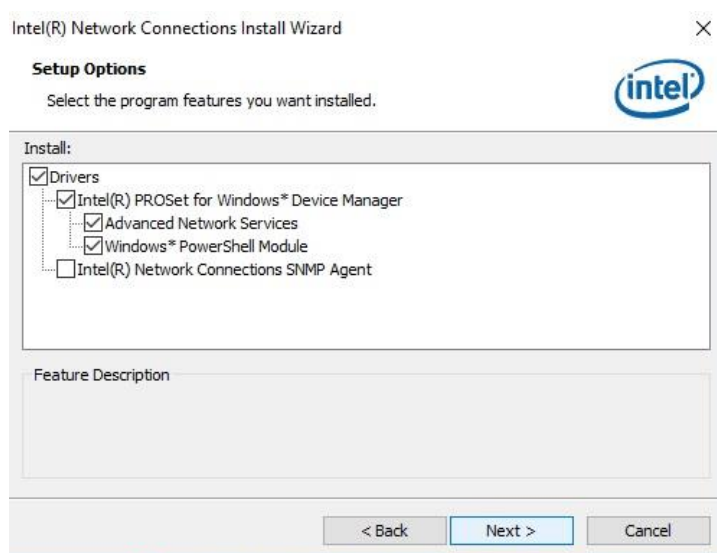

5. When the wizard is ready for installation, click **Install**.
6. Installation is now complete. Restart the system for changes to take effect.

3.6 Intel® Management Engine Components Drivers Installation

1. Run the **Setup.exe** file.
2. When the *Welcome* screen appears, click **Next**.

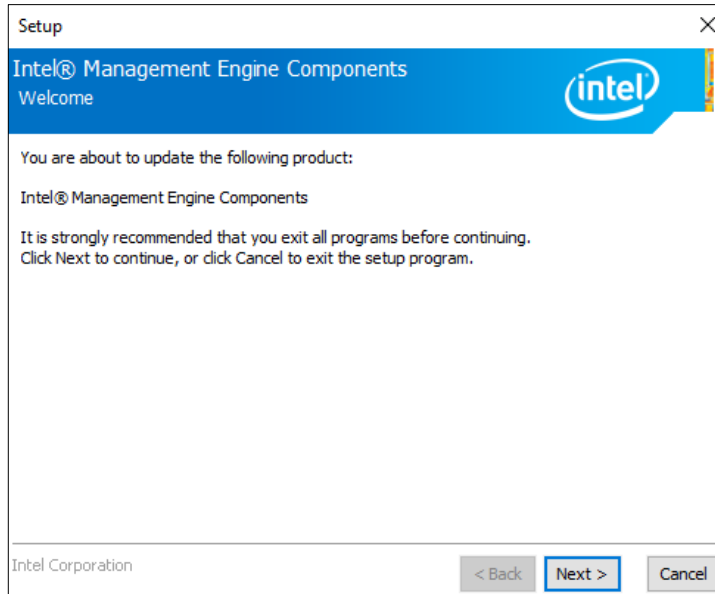

3. Accept the license agreement and click **Next** for installation.

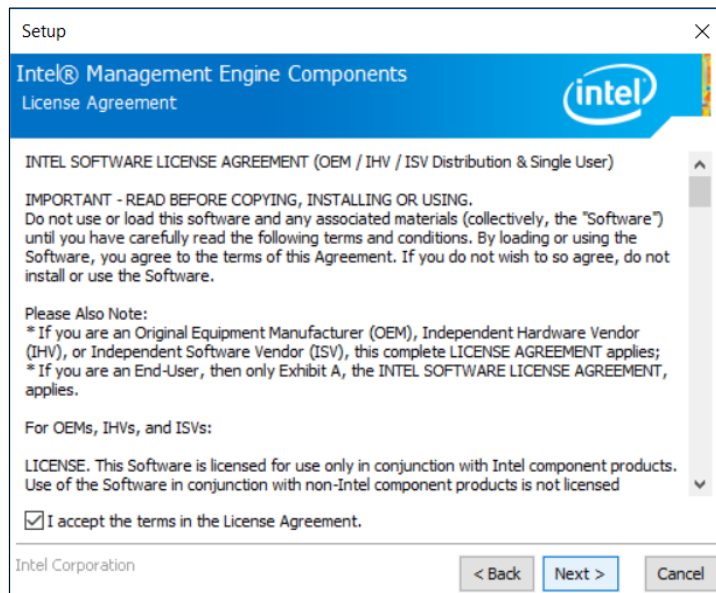

4. Installation is now complete. Restart the system for changes to take effect.

Chapter 4

BIOS Setup

This chapter describes the different settings available in the AMI BIOS that comes with the board. The topics covered in this chapter are as follows:

- Main Settings
- Advanced Settings
- Chipset Settings
- Security Settings
- Boot Settings
- Save & Exit

4.1 Introduction

The BIOS (Basic Input/Output System) installed in the ROM of your computer system supports Intel® processors. The BIOS provides critical low-level support for standard devices such as disk drives, serial ports and parallel ports. It also provides password protection as well as special support for detailed fine-tuning of the chipset controlling the entire system.

4.2 BIOS Setup

The BIOS provides a Setup utility program for specifying the system configurations and settings. The BIOS ROM of the system stores the Setup utility. When you turn on the computer, the BIOS is immediately activated. Press the key immediately allows you to enter the Setup utility. If you are a little bit late pressing the key, POST (Power On Self Test) will continue with its test routines, thus preventing you from invoking the Setup.

If you still need to enter Setup, restart the system by pressing the "Reset" button or simultaneously pressing the <Ctrl>, <Alt> and <Delete> keys. You can also restart by turning the system Off and back On again.

The following message will appear on the screen:

```
Press <DEL> to Enter Setup
```

In general, press the arrow keys to highlight items, <Enter> to select, the <PgUp> and <PgDn> keys to change entries, <F1> for help, and <Esc> to quit.

When you enter the BIOS Setup utility, the *Main Menu* screen will appear on the screen. The Main Menu allows you to select from various setup functions and exit choices.

Warning: It is strongly recommended that you avoid making any changes to the chipset defaults.

These defaults have been carefully chosen by both AMI and your system manufacturer to provide the absolute maximum performance and reliability. Changing the defaults could make the system unstable and crash in some cases.

4.3 Main Settings

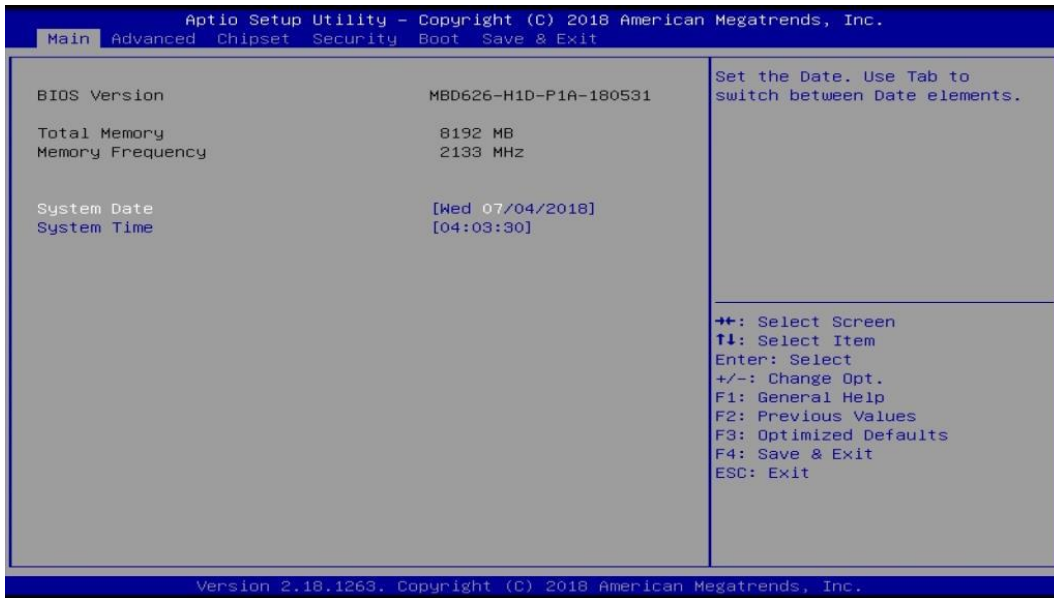

BIOS Setting	Description
System Date	Sets the date. Use the <Tab> key to switch between the data elements.
System Time	Set the time. Use the <Tab> key to switch between the data elements.

4.4 Advanced Settings

This section allows you to configure, improve your system and allows you to set up some system features according to your preference.

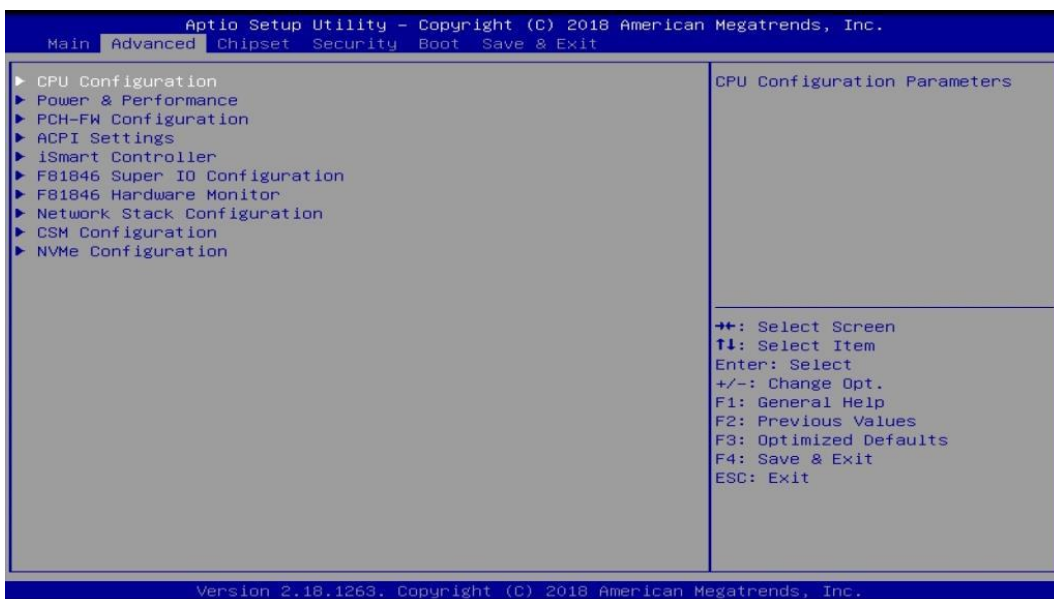

4.4.1 CPU Configuration

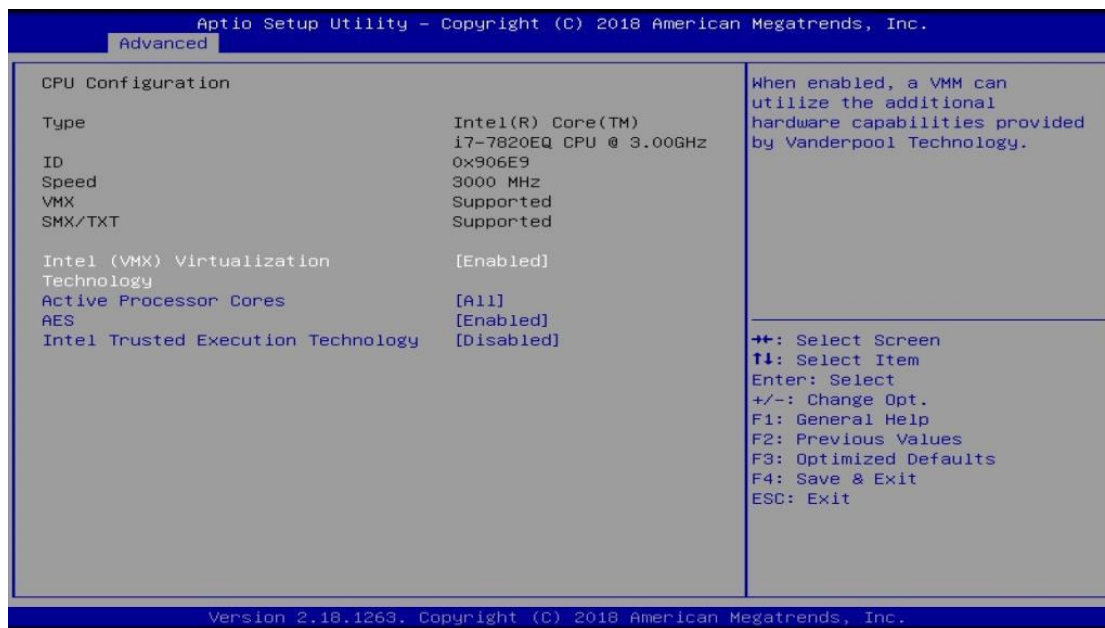

BIOS Setting	Description
Intel (VMX) Virtualization Technology	When the function is enabled, a VMM can utilize the additional hardware capabilities provided by Vanderpool Technology.
Active Processor Cores	Number of cores to enable in each processor package.
AES	Enables / Disables AES (Advanced Encryption Standard).
Intel Trusted Execution Technology	Enables utilization of additional hardware capabilities provided by Intel(R) Trusted Execution Technology. Changes require a full power cycle to take effect.

4.4.2 Power & Performance



BIOS Setting	Description
CPU Power Management Control	CPU – Power Management Control Options

4.4.2.1. CPU Power Management Control



BIOS Setting	Description
Intel Speed Step(tm)	Allows more than two frequency ranges to be supported.
Intel(R) Speed Shift Technology Turbo Mode	Enables / Disables Intel(R) Speed Shift Technology support. Enabling will expose the CPPC v2 interface to allows for hardware controlled P-states.
Turbo Mode	Enables / Disables processor Turbo Mode (requires EMTTM enabled too). Auto means enabled unless max. turbo ratio is bigger than 16 – SKL A0 W/A.

4.4.3 PCH-FW Configuration

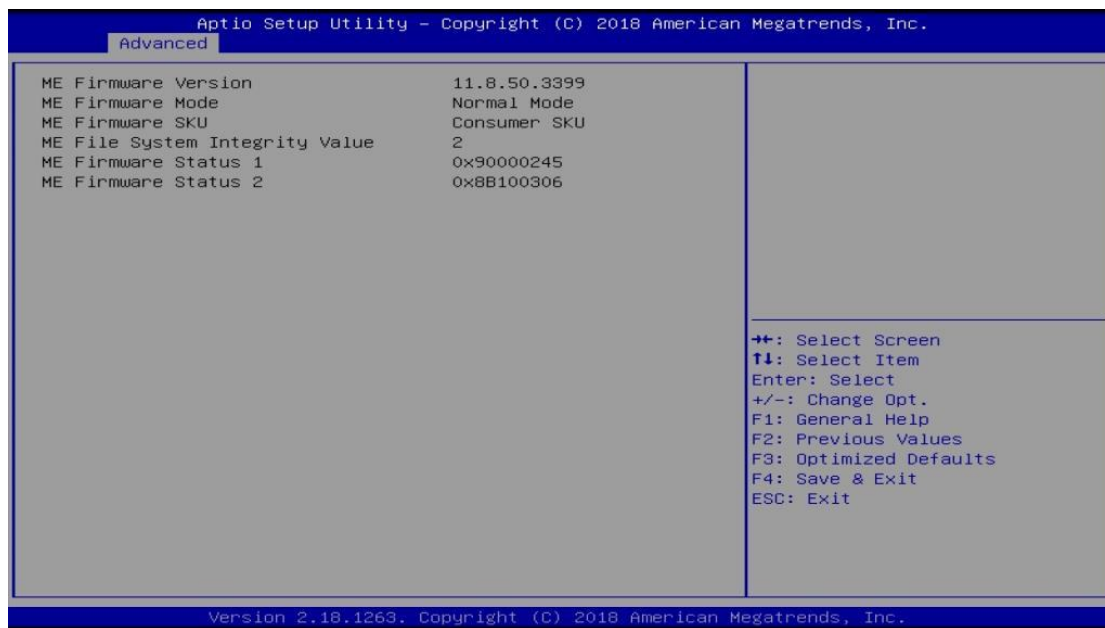

4.4.4 ACPI Settings



BIOS Setting	Description
Enable Hibernation	Enables / Disables System ability to hibernate (OS/S4 Sleep State). This option may not be effective with some operating systems.
ACPI Sleep State	Select the highest ACPI sleep state the system will enter when the Suspend button is pressed.
Lock Legacy Resources	Enables / Disables Lock of Legacy Resources.

4.4.5 iSmart Controller

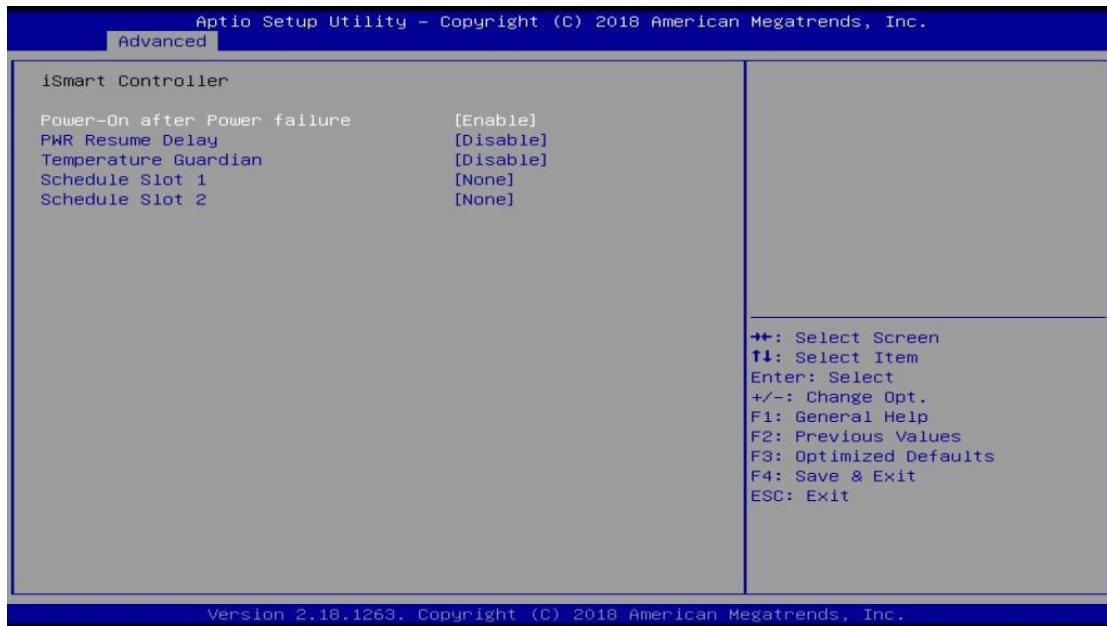

BIOS Setting	Description
Power-On after Power failure	Enables / Disables the system to be turned on automatically after a power failure.
PWR Resume Delay	Enables / Disables power-on resume delay.
Temperature Guardian	Generate the reset signal when system hands up on POST.
Schedule Slot 1 / 2	<p>Sets up the hour / minute for system power-on.</p> <p>Important: If you would like to set up a schedule between adjacent days, configure two schedule slots.</p> <p>For example, if setting up a schedule from Wednesday 5 p.m. to Thursday 2 a.m., configure two schedule slots. But if setting up a schedule from 3 p.m to 5 p.m. on Wednesday, configure only a schedule slot.</p>

4.4.6 F81846 Super IO Configuration

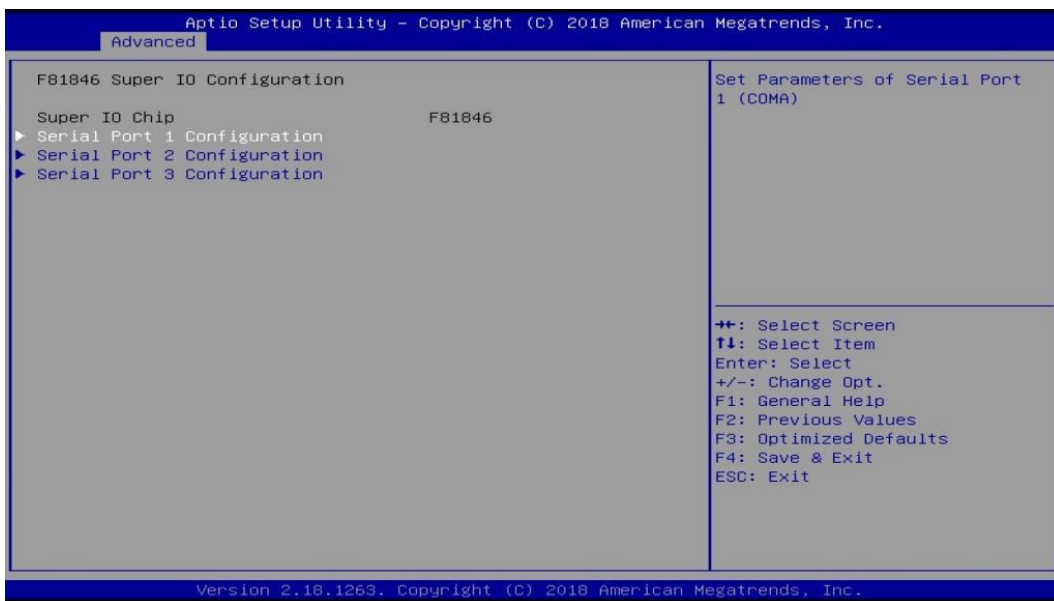

BIOS Setting	Description
Serial Port Configuration	Sets parameters of Serial Ports (COMA). Enables / Disables the serial port and select an optimal setting for the Super IO device.

4.4.7 Hardware Monitor

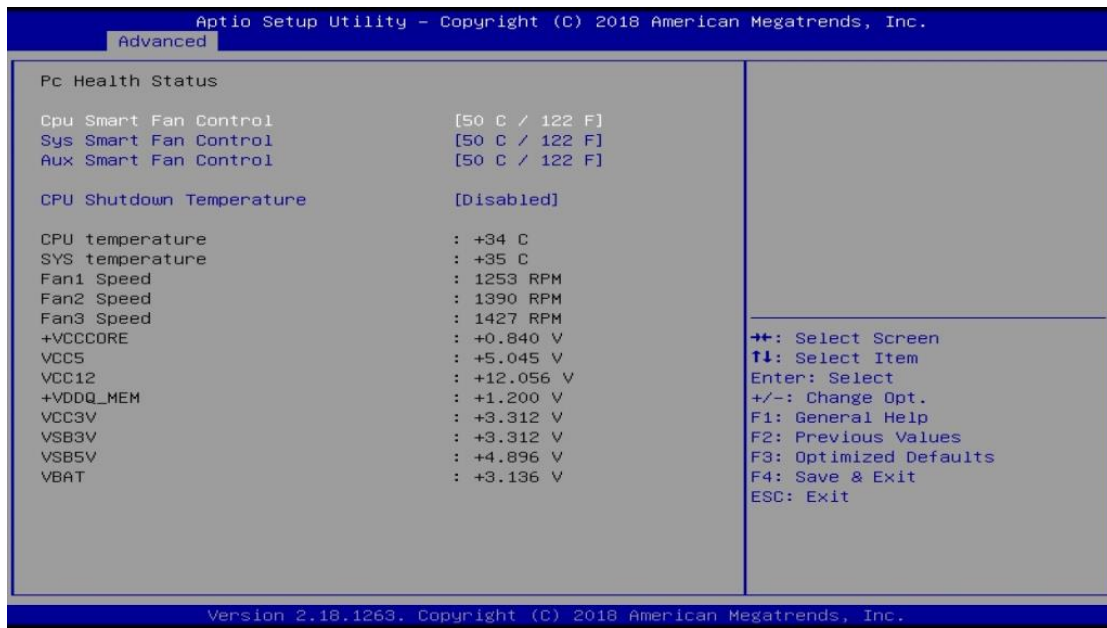

BIOS Setting	Description
CPU / System / Aux Smart Fan Control	Controls the temperter limit of CPU or system.
CPU Shutdown Temperature	This field enables or disables the Shutdown Temperature
Temperatures / Voltages	These fields are the parameters of the hardware monitoring function feature of the motherboard. The values are read-only values as monitored by the system and show the PC health status.

4.4.8 Network Stack Configuration

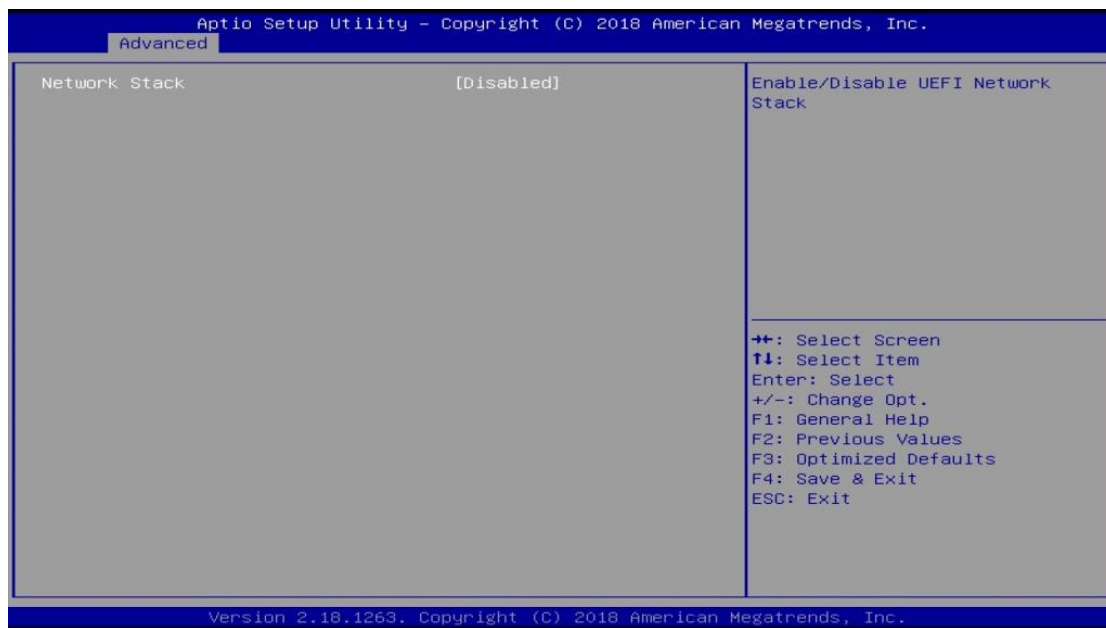

BIOS Setting	Description
Network Stack	Enables / Disables UEFI network stack.
IPv4 PXE Support	Enables / Disables IPv4 PXE Boot Support. If disabled, Ipv4 PXE boot option will not be created.
IPv4 HTTP Support	Enables / Disables IPv4 HTTP Boot Support. If disabled, Ipv4 HTTP boot option will not be created.
IPv6 PXE Support	Enables / Disables IPv6 PXE Boot Support. If disabled, Ipv4 PXE boot option will not be created.
IPv6 HTTP Support	Enables / Disables IPv6 HTTP Boot Support. If disabled, Ipv4 HTTP boot option will not be created.
PXE boot wait time	Assigns a period of time to press ESC key to abort the PXE boot.
Media detect count	Assigns a number of times to check the presence of media.

4.4.9 CSM Configuration

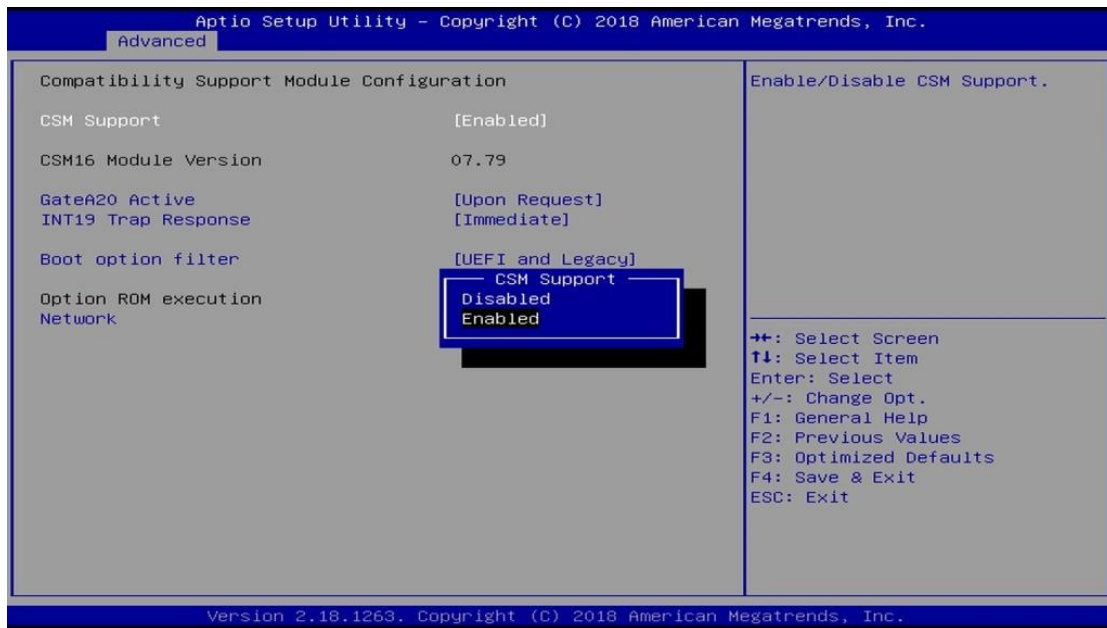

BIOS Setting	Description
CSM Support	Enables / Disables CSM support.
GateA20 Active	<ul style="list-style-type: none"> The option Upon Request disables GA20 when using BIOS services. The option Always cannot disable GA20, but is useful when any RT code is executed above 1 MB.
INT19 Trap Response	Selects the way that BIOS reacts on INT19 trapping by Option ROM. <ul style="list-style-type: none"> Immediate executes the trap right away Postponed executes the trap during legacy boot.
Boot option filter	Controls the priority of Legacy and UEFI.
Network	Controls the execution of UEFI and Legacy PXE OpROM.

4.4.10 NVMe Configuration

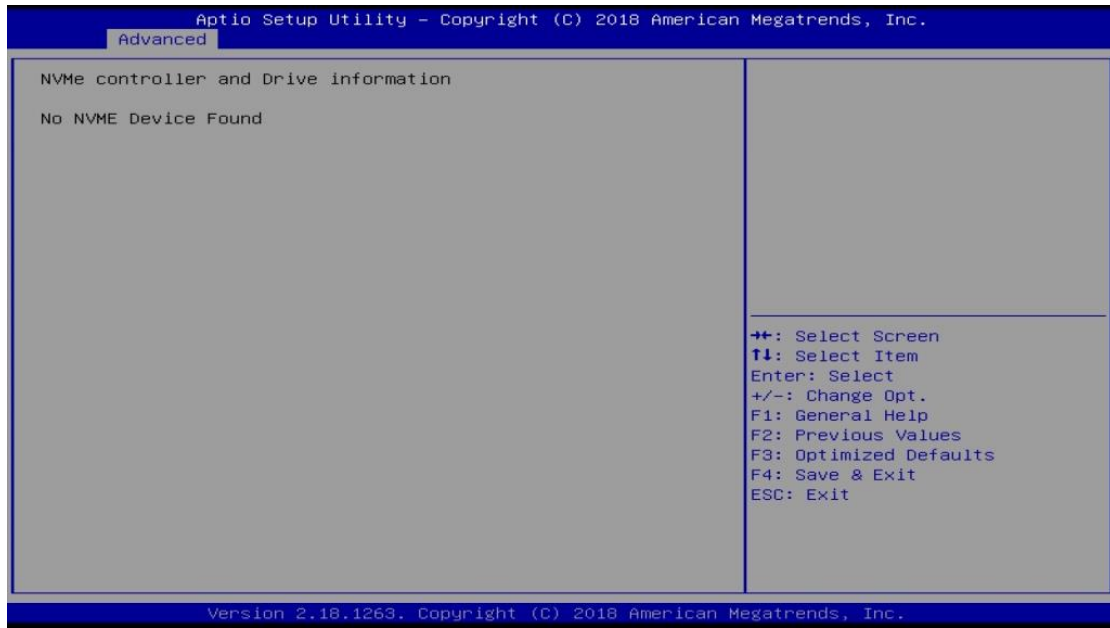

4.5 Chipset Settings

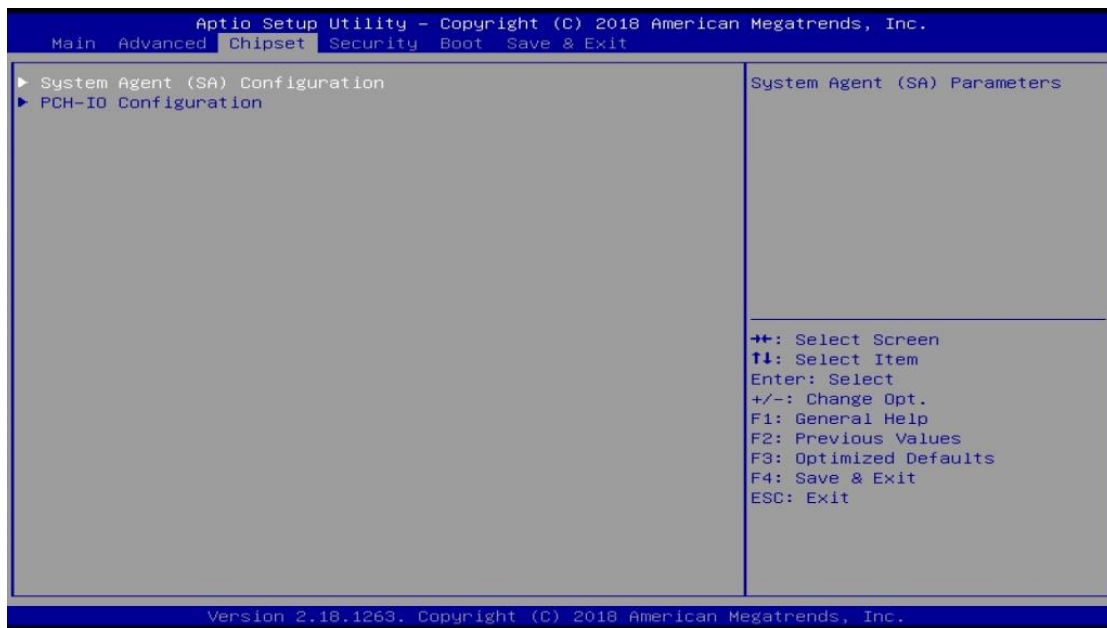

BIOS Setting	Description
System Agent (SA) Configuration	System Agent parameters
PCH-IO Configuration	PCH parameters

4.5.1 System Agent Configuration

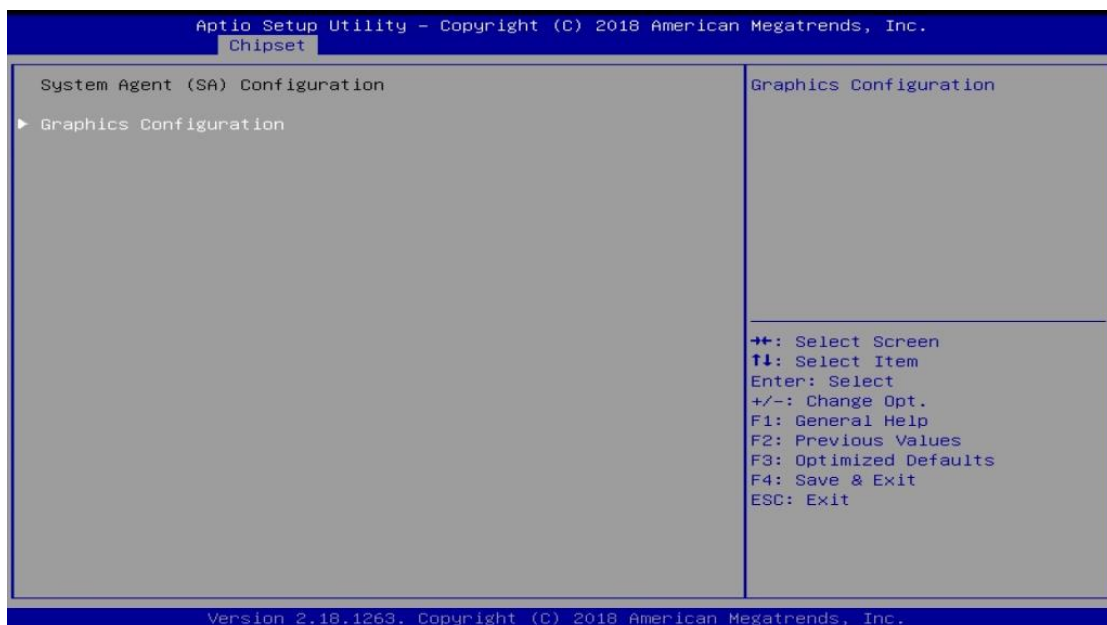

4.5.2 PCH-IO Configuration

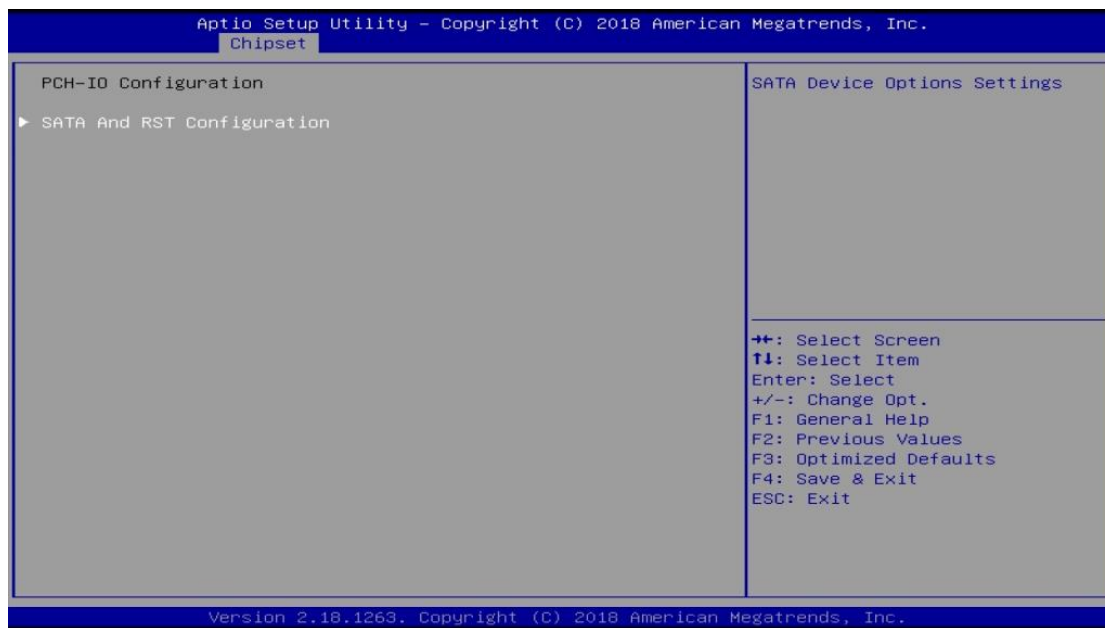

BIOS Setting	Description
SATA and RST Configuration	SATA device options settings

4.5.2.1 SATA and RST Configuration

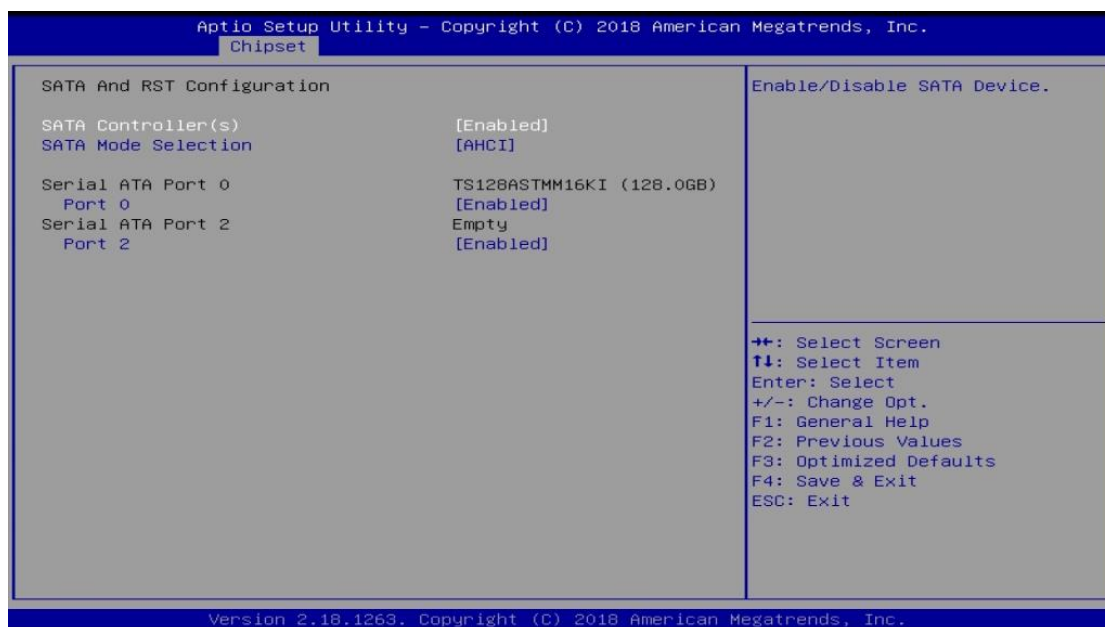

BIOS Setting	Description
SATA Controller(s)	Enables / Disables the SATA device.

4.6 Security Settings

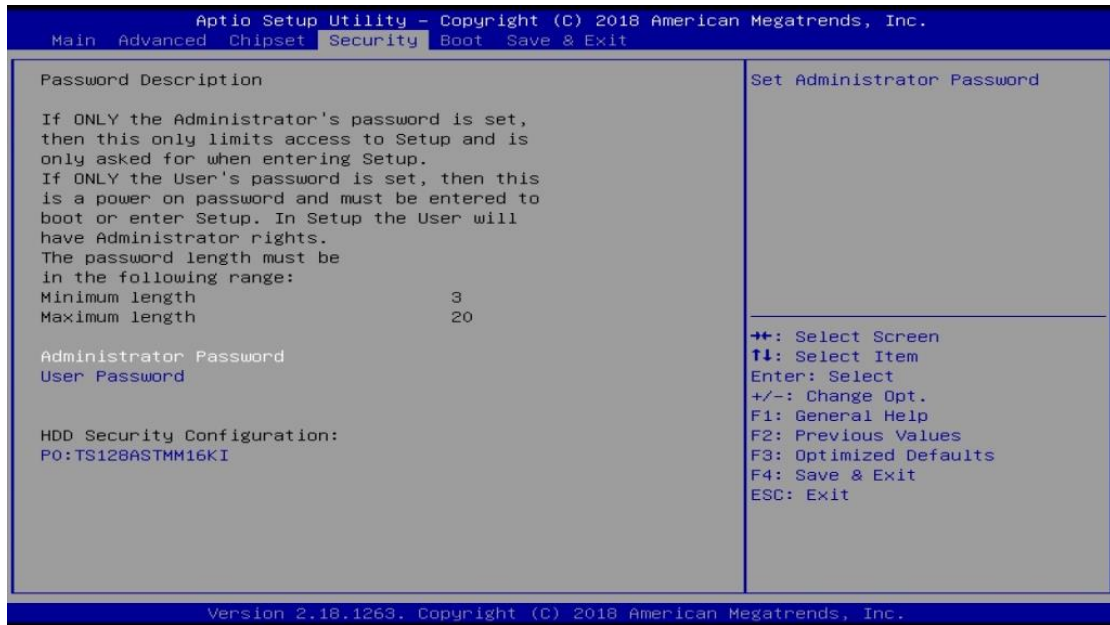

BIOS Setting	Description
Administrator Password	Sets an administrator password for the setup utility.
User Password	Sets a user password.

4.7 Boot Settings

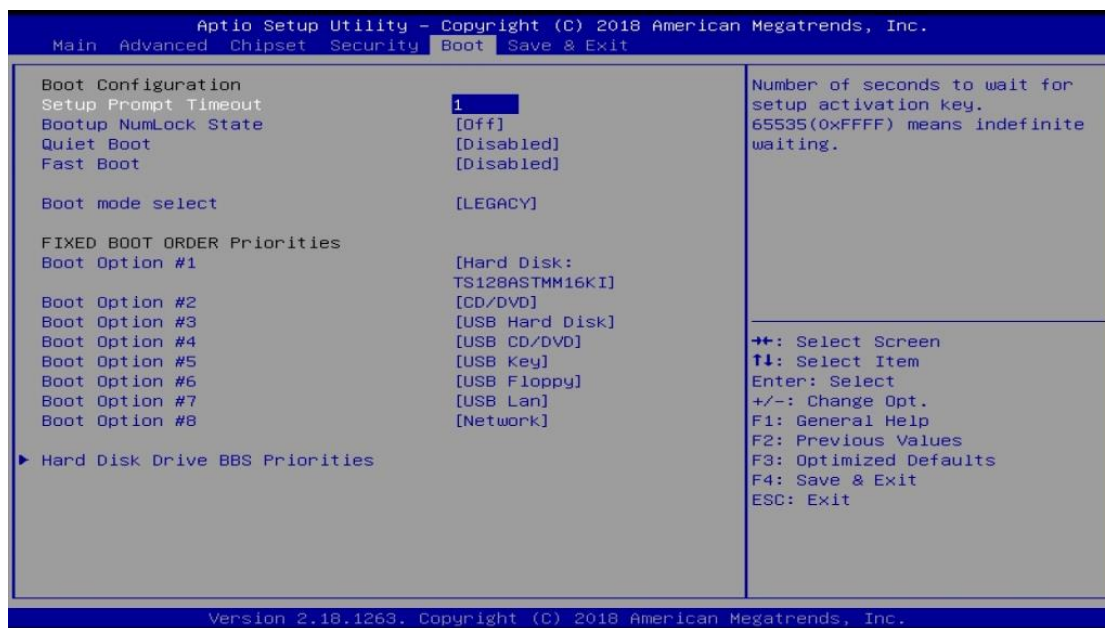

BIOS Setting	Description
Setup Prompt Timeout	Number of seconds to wait for setup activation key. 65535 (0xFFFF) means indefinite waiting.
Bootup NumLock State	Selects the keyboard NumLock state.
Quiet Boot	Enables / Disables Quiet Boot option.
Fast Boot	Enables / Disables boot with initialization of a minimal set of devices required to launch the active boot option. There no effect for BBS boot options.
Boot Mode Select	Selects a Boot mode.
Boot Option Priorities	Sets the system boot order priorities for hard disk, CD/DVD, USB, Network.

4.8 Save & Exit Settings

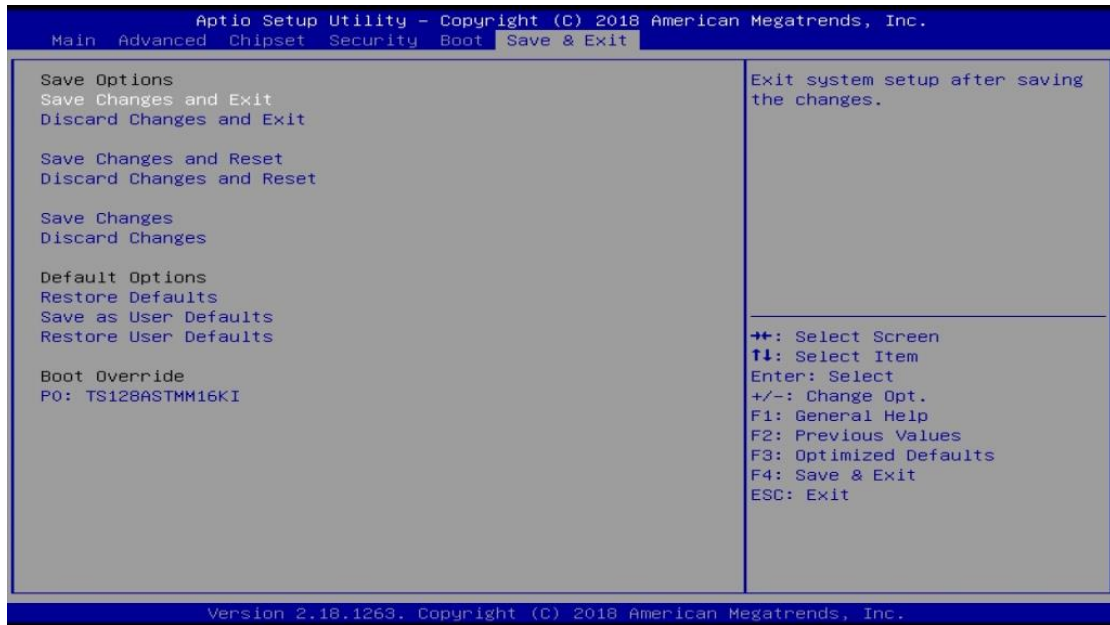

BIOS Setting	Description
Save Changes and Exit	Exits system setup after saving the changes.
Discard Changes and Exit	Exits system setup without saving any changes.
Save Changes and Reset	Resets the system after saving the changes.
Discard Changes and Reset	Resets system setup without saving any changes.
Save Changes	Saves changes done so far to any of the setup options.
Discard Changes	Discards changes done so far to any of the setup options.
Restore Defaults	Restores / Loads defaults values for all the setup options.
Save as User Defaults	Saves the changes done so far as user defaults.
Restore User Defaults	Restores the user defaults to all the setup options.

Appendix

This section provides the mapping addresses of peripheral devices and the sample code of watchdog timer configuration.

- AMD Eyefinity Multiple Displays
- I/O Port Address Map
- Interrupt Request Lines (IRQ)
- Watchdog Timer Configuration

A. AMD Eyefinity Multiple Displays Configuration

AMD Eyefinity is applicable to SI-61S; it is a technology that allows two or more displays to be grouped together to form a single large desktop. Once AMD Eyefinity is configured, the final resolution is the horizontal and/or vertical sum of the individual monitors.

The following AMD embedded configurations are used for the demonstration of AMD Eyefinity configuration in this section.

Platform: AMD Embedded V1000 Reference Platform

APU: AMD Embedded V1000 Processor with AMD Radeon Vega Graphics

AMD Driver: 17.40.3775.1003.180508a-328988C-AES

A.1 Setting Up AMD Eyefinity Using Quick Setup

A.1.1 AMD Eyefinity Quick Setup with All Displays

This section describes how to set up AMD Eyefinity with the Quick Setup option, where all the connected displays will be part of the AMD Eyefinity Display Group created.

As AMD Eyefinity Quick Setup creates an Eyefinity Display Group based on the current (default) display configuration, ensure that the displays are arranged in the desired supported order first under extended desktop in the Operating System's display settings.

In the below example, Eyefinity Quick Setup is used to create a 3x1 AMD Eyefinity Display Group. So, arrange the displays in a 3x1 configuration in extended desktop before configuring AMD Eyefinity with Quick Setup.

To set up AMD Eyefinity with Quick Setup:

1. Open AMD Radeon Settings: Right-click on the desktop and select **AMD Radeon Settings**.

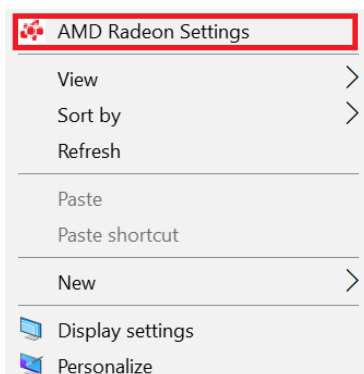

2. Click **Eyefinity** once **AMD Radeon Settings** opens.



3. Click **Quick Setup** to automatically create an AMD Eyefinity Display Group based on the current (default) display configuration.

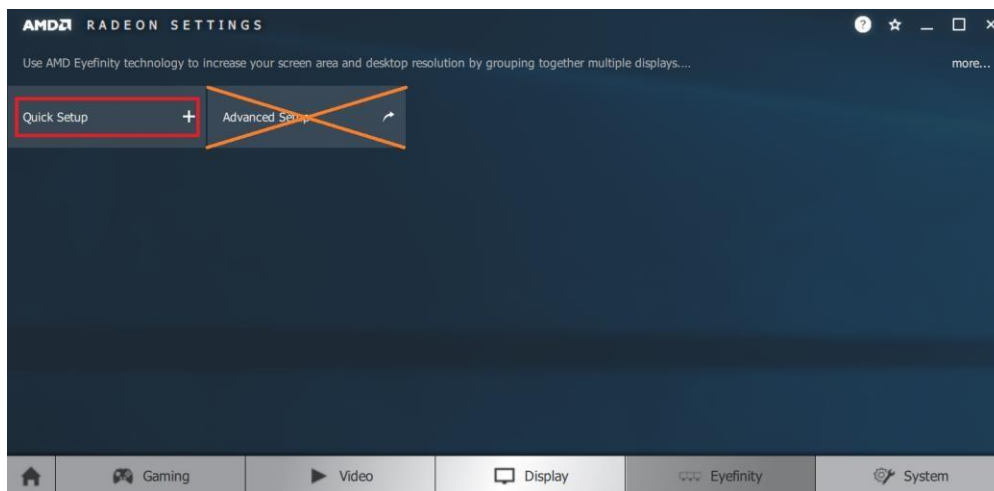

Note: At the time of writing, **Advanced Setup** for configuring Eyefinity is available. However, this feature is not supported. Do not confuse with **Try Advanced Setup** (see below picture), which becomes available after Eyefinity Quick Setup is complete. The **Try Advanced Setup** option is used to customize the Eyefinity Display Group created after Eyefinity Quick Setup is complete.

4. In this example, a 3x1 Eyefinity Display Group is created as shown below.

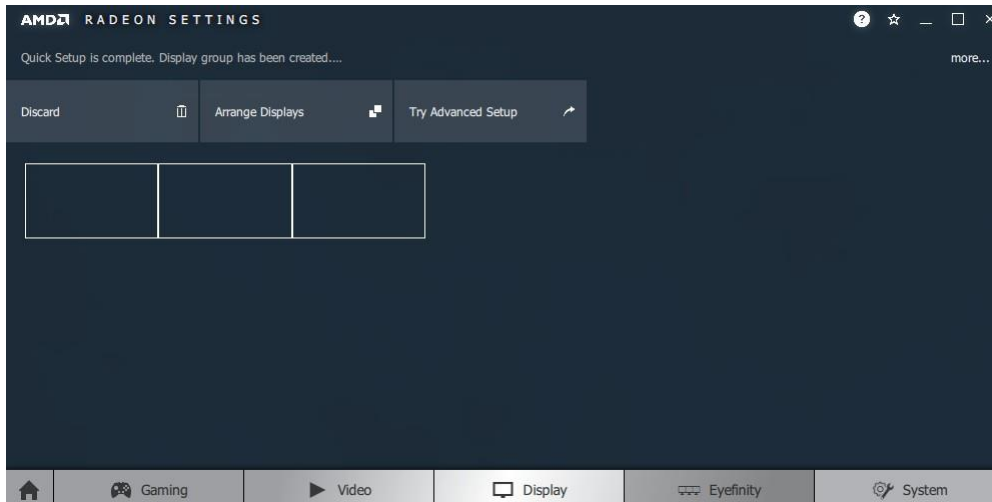

5. Once the AMD Eyefinity Display Group is created, the following options become available:
- **Discard** – Removes the AMD Eyefinity setup and restores the previous display configuration.
 - **Arrange Displays** – Arrange the position of each display in the AMD Eyefinity Display Group. Refer to the next section *Arrange Displays after Eyefinity Quick Setup* for details.
 - **Try Advanced Setup** – Additional settings to customize the AMD Eyefinity Display Group. Refer to *A.2 Customizing AMD Eyefinity Using Try Advanced Setup* for details.

Arrange Displays after Eyefinity Quick Setup

To arrange displays in desired positions (optional):

1. Click **Arrange Displays** after Eyefinity Quick Setup is complete.

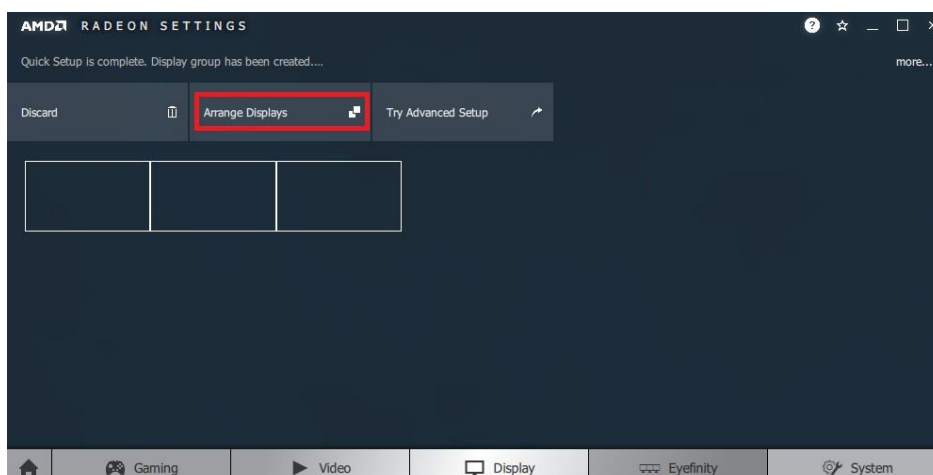

- The onscreen guide will show a grid representation of the Eyefinity Display Group and one of the physical displays will have a blue background.

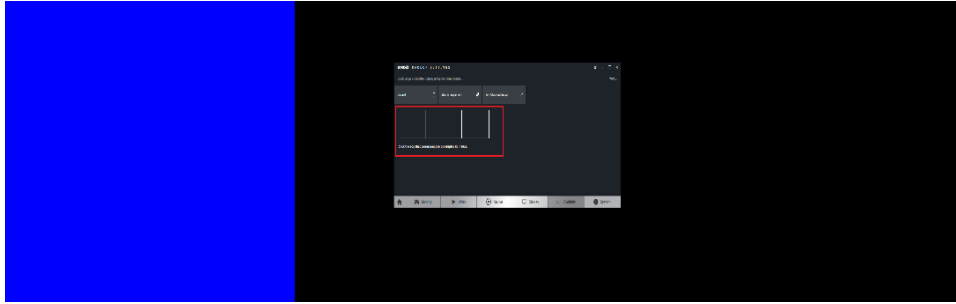

- Click on the box in the grid that matches the desired location of the highlighted display in blue.

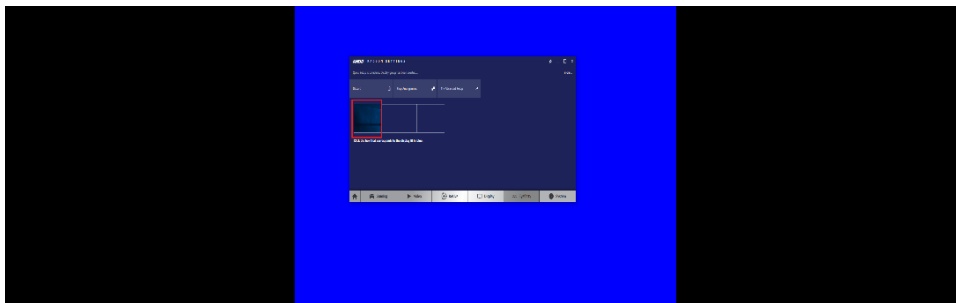

- Repeat Step #3 with the rest of displays to complete the **Arrange Displays** setup.

A.1.2 AMD Eyefinity Quick Setup with Part of All Displays

As mentioned previously, since Eyefinity Quick Setup uses the current (default) display configuration which involves all the connected displays, configuring Eyefinity with only a portion of the connected displays is not allowed.

For example, setting up 3 x 1 Eyefinity with 4 connected displays is not possible with Eyefinity Quick Setup.

The following example, which sets up 3 x 1 Eyefinity (Quick Setup) with a total of 4 x 4k connected displays, demonstrates the method to work around the limitation:

- Physically connect the displays to be used for the Eyefinity Display Group. In this setup, the number of displays for Eyefinity should be less than the total number of displays to be used in the overall setup (i.e. Eyefinity Display Group + Extended Desktop Displays).

In this example, physically connect 3 of the 4 displays first and arrange them in 3 x 1 extended desktop in the Operating System's display settings.

iBASE

2. Follow the steps in Section 2.1, “AMD Eyefinity Quick Setup with All Displays” to configure Eyefinity.

In this example, a 3 x 1 Eyefinity Display Group has been created with 3 x 4k displays after Eyefinity Quick Setup is complete.

3. Once the 3 x 1 Eyefinity Display Group is created, connect (hotplug) the fourth display to the AMD graphics device.

The resulting setup consists of a 3 x 1 Eyefinity Display Group (11520 x 2160 resolution) + 1 x 4k (3840 x 2160 resolution) (in extended desktop).

A.2 Customizing AMD Eyefinity Using Try Advanced Setup

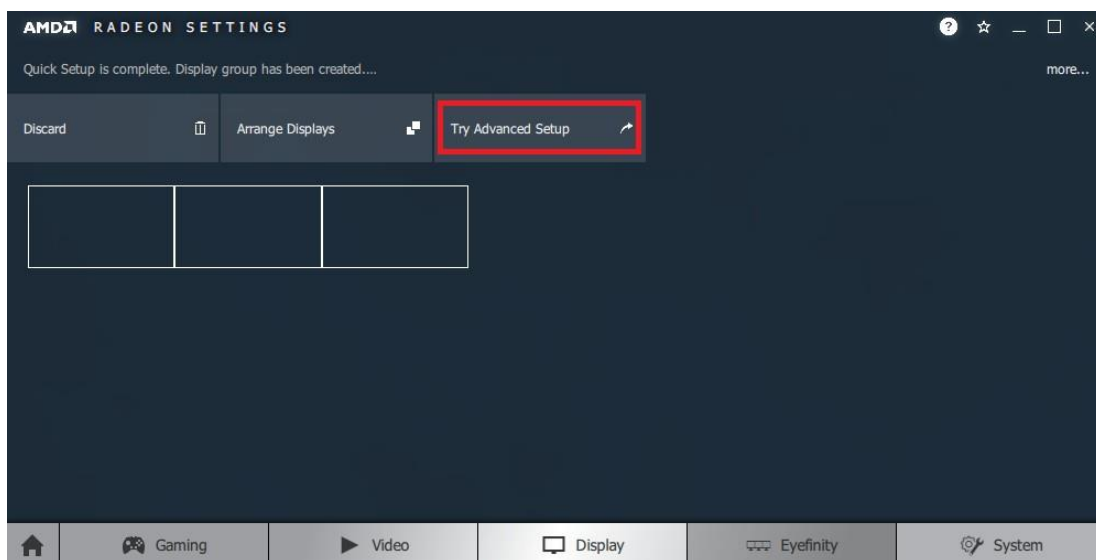

Try Advanced Setup becomes available after Eyefinity Quick Setup is complete (see above picture). It offers customization for the Eyefinity Display Group created, with options such as:

- Position Windows Taskbar
- Arrange Eyefinity Display Group
- Resize Desktop
- Disable Eyefinity Display Group
- Adjust Bezel Compensation
- Customize Eyefinity Desktop Resolution

A.2.1 Position Windows Taskbar

The **Position Windows Taskbar** option allows adjusting the Taskbar across all displays in the Eyefinity Display Group or in one preferred display. By default, the Taskbar extends across all displays in a single row AMD Eyefinity Display Group. In a multi-row AMD Eyefinity Display Group, it extends across the bottom row of displays.

To set the Taskbar position:

1. Click **Try Advanced Setup** (under **Eyefinity** tab in AMD Radeon Settings) after Eyefinity Quick Setup is complete.
2. Click **Position Windows Taskbar** once Radeon Additional Settings launches.
3. Check the **Position the Windows taskbar on a single display** option and click **Continue**.



4. To move the Taskbar, simply drag and drop it to the desired display. Ensure that the Taskbar setting is not set to "locked".
5. To have the Taskbar running across multiple displays again, uncheck the **Position the Windows taskbar on a single display** option and click **Continue**.

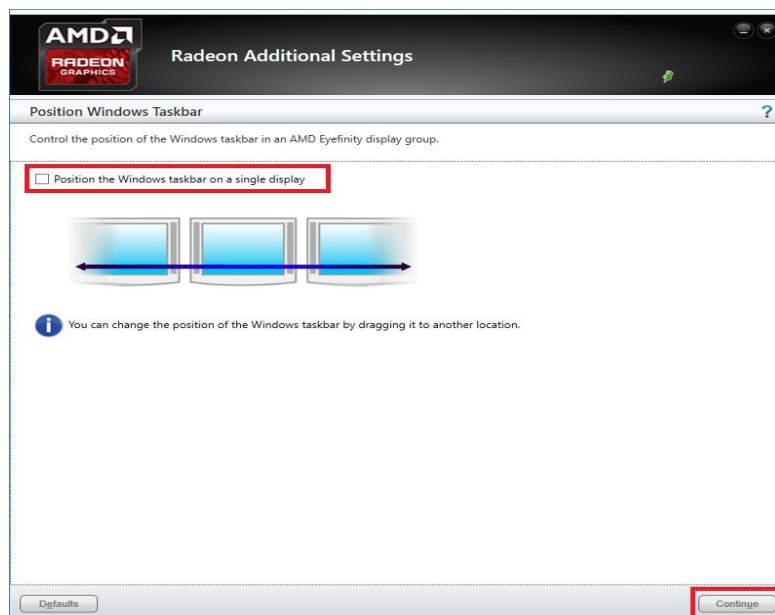

A.2.2 Arrange Eyefinity Display Group

The **Arrange Eyefinity Display Group** option allows re-arranging the order of the displays in an AMD Eyefinity Display Group if needed.

To re-arrange the displays in an Eyefinity Display Group:

1. Click **Try Advanced Setup** (under **Eyefinity** tab in AMD Radeon Settings) after Eyefinity Quick Setup is complete.
2. Click **Arrange Eyefinity Display Group** once Radeon Additional Settings launches.
3. Use the same method as described in Section 2.1.1, “Arrange Displays after Eyefinity Quick Setup” (Step #2 to #4) to complete re-arranging the displays in an Eyefinity Display Group.

A.2.3 Resize Desktop

When displays in an AMD Eyefinity Display Group are configured to use different resolutions, rotations, or alignments, the desktop image may appear stretched or cropped. In an AMD Eyefinity Group consisting of displays with mixed dimensions (different sizes, resolutions, orientations), the **Resize Desktop** option changes how the desktop image is shown across the displays by resizing it.

To resize the desktop:

1. Click **Try Advanced Setup** (under **Eyefinity** tab in AMD Radeon Settings) after Eyefinity Quick Setup is complete.
2. Click **Resize Desktop** once Radeon Additional Settings launches.

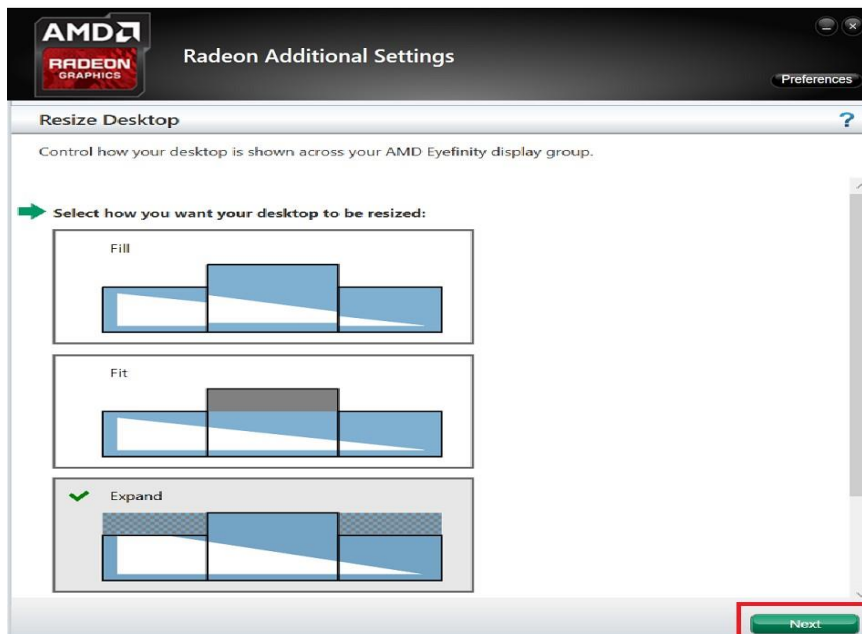

3. Choose one of the following options:
 - **Fill** - Fill the entire area of each display with its portion of the desktop. The desktop may appear stretched on certain displays.
 - **Fit** - Resize the desktop to the height of the shortest display. Show the entire desktop across all displays without cropping or stretching the desktop. Certain areas of your displays may appear blank.
 - **Expand** - Resize the desktop to the height of the tallest display. Portions of the desktop, for example, the Taskbar, may appear cropped or missing on certain displays.
4. Click **Next** to complete and save the setup.

A.2.4 Disable Eyefinity Display Group

The **Disable Eyefinity Display Group** option disables an already configured Eyefinity Display Group to return all displays in the group to the original display configuration.

To disable the Eyefinity Display Group:

1. Click **Try Advanced Setup** (under **Eyefinity** tab in AMD Radeon Settings) after Eyefinity Quick Setup is complete.
2. Click **Disable Eyefinity Display Group** once Radeon Additional Settings launches.

A.2.5 Adjust Bezel Compensation

In an AMD Eyefinity Display Group the edges (bezels) of the displays may cause the image to appear disjointed or not continuous. The **Adjust Bezel Compensation** feature provides alignment functions that allow the desktop to appear continuous across all displays in an Eyefinity Display Group.

To adjust bezel compensation:

1. Click **Try Advanced Setup** (under **Eyefinity** tab in AMD Radeon Settings) after Eyefinity Quick Setup is complete.
2. Click **Adjust Bezel Compensation** once Radeon Additional Settings launches.
3. Use the Chevrons (arrow heads) to move the triangle test pattern until it is properly aligned (as shown in below picture).

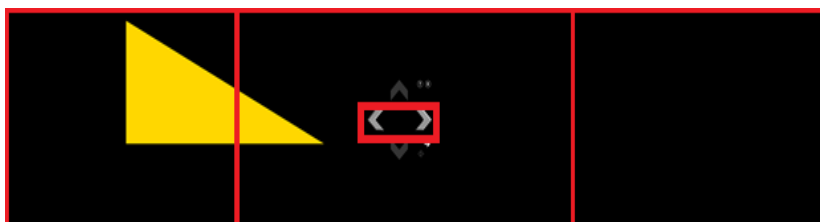

4. Click on the directional arrow:



Then click **No** for the “Are the test patterns correct?” box to repeat Step #3 for the next set of bezels.

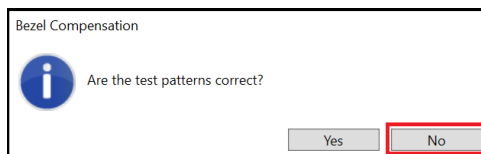

5. When complete, click the **X** button and Yes to save the changes and close the tool.

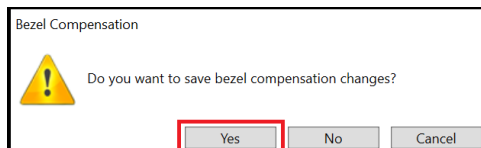

A.2.6 Customize Eyefinity Desktop Resolution

The **Customize Eyefinity Desktop Resolution** option allows the desktop size of an AMD Eyefinity Display Group to be changed to any resolution that is listed in the Custom Resolution drop-down menu. Once the desired Custom Resolution is chosen in **Customize Eyefinity Desktop Resolution**, this particular resolution becomes available in the Operating System’s display settings menu for selection.

To customize Eyefinity desktop resolution:

1. Click **Try Advanced Setup** (under **Eyefinity** tab in AMD Radeon Settings) after Eyefinity Quick Setup is complete.
2. Click **Customize Eyefinity Desktop Resolution** once Radeon Additional Settings launches.

3. In the **Customize Eyefinity Desktop Resolution** menu, the minimum and maximum resolutions are automatically determined based on your displays and cannot be changed. Use the **Custom Resolution** drop-down menu to select from a list of supported resolutions.

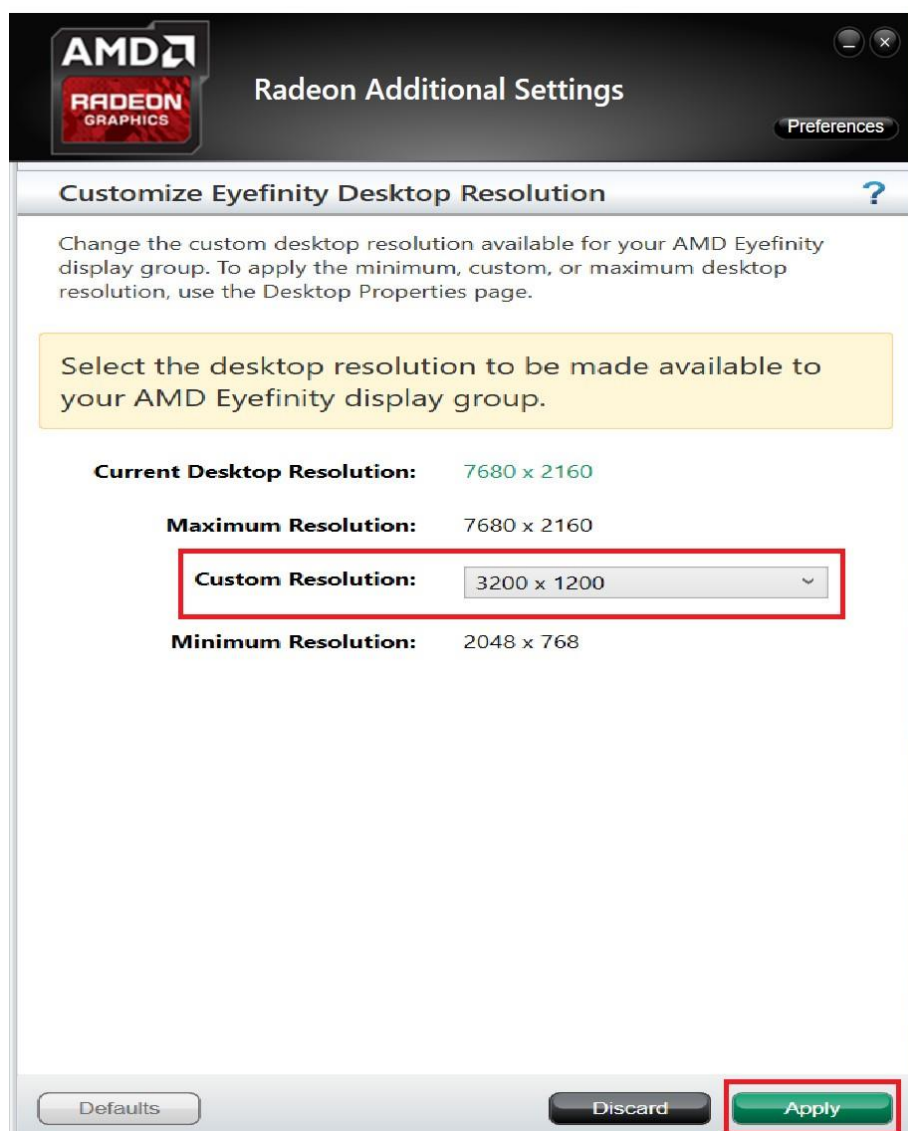

4. Select the preferred resolution from the **Custom Resolution** drop-down menu, and click **Apply** to save the setting.
5. Open the Operating System's display settings menu to change the resolution to the Custom Resolution selected in Step #4.

A.3 Video Wall Layouts Applicable to SI-626

Configure the matrix grid layouts of video walls with AMD Eyefinity per the following display arrangement.

For 3 displays output:

- 3 x 1 Landscape Display Group



- 3 x 1 Portrait Display Group



- 1 x 3 Landscape Display Group

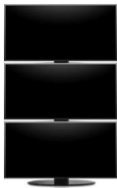

- 1 x 3 Portrait Display Group



For 4 displays output:

- 4 x 1 Landscape Display Group



- 4 x 1 Portrait Display Group



- 1 x 4 Landscape Display Group

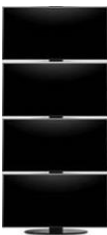

- 1 x 4 Portrait Display Group



- 2 x 2 Landscape Display Group



- 2 x 2 Portrait Display Group



For 5 displays output:

- 5 x 1 Landscape Display Group



- 5 x 1 Portrait Display Group



- 1 x 5 Landscape Display Group

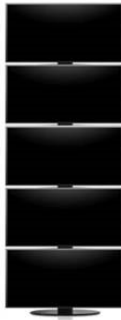

For 6 displays output:

- 3 x 2 Landscape Display Group



- 2 x 3 Landscape Display Group



B. I/O Port Address Map

Each peripheral device in the system is assigned a set of I/O port addresses which also becomes the identity of the device. The following table lists the I/O port addresses used.

Address	Device Description
0x00000A00-0x00000A0F	Motherboard resources
0x00000A10-0x00000A1F	Motherboard resources
0x00000A20-0x00000A2F	Motherboard resources
0x0000002E-0x0000002F	Motherboard resources
0x0000004E-0x0000004F	Motherboard resources
0x00000061-0x00000061	Motherboard resources
0x00000063-0x00000063	Motherboard resources
0x00000065-0x00000065	Motherboard resources
0x00000067-0x00000067	Motherboard resources
0x00000070-0x00000070	Motherboard resources
0x00000070-0x00000070	System CMOS/real time clock
0x00000080-0x00000080	Motherboard resources
0x00000092-0x00000092	Motherboard resources
0x000000B2-0x000000B3	Motherboard resources
0x00000680-0x0000069F	Motherboard resources
0x0000FFFF-0x0000FFFF	Motherboard resources
0x0000FFFF-0x0000FFFF	Motherboard resources
0x0000FFFF-0x0000FFFF	Motherboard resources
0x00001800-0x000018FE	Motherboard resources
0x0000164E-0x0000164F	Motherboard resources
0x0000D000-0x0000D0FF	Realtek PCIe GBE Family Controller #2
0x0000D000-0x0000D0FF	Intel(R) 100 Series/C230 Series Chipset Family PCI Express Root Port #4 - A113
0x0000E000-0x0000EFFF	Intel(R) Xeon(R) E3 - 1200/1500 v5/6th Gen Intel(R) Core(TM) PCIe Controller (x16) - 1901
0x0000E000-0x0000EFFF	AMD Radeon E8860

Address	Device Description
0x000003B0-0x000003BB	Intel(R) Xeon(R) E3 - 1200/1500 v5/6th Gen Intel(R) Core(TM) PCIe Controller (x16) - 1901
0x000003B0-0x000003BB	AMD Radeon E8860
0x000003C0-0x000003DF	Intel(R) Xeon(R) E3 - 1200/1500 v5/6th Gen Intel(R) Core(TM) PCIe Controller (x16) - 1901
0x000003C0-0x000003DF	AMD Radeon E8860
0x00000800-0x0000087F	Motherboard resources
0x00000020-0x00000021	Programmable interrupt controller
0x00000024-0x00000025	Programmable interrupt controller
0x00000028-0x00000029	Programmable interrupt controller
0x0000002C-0x0000002D	Programmable interrupt controller
0x00000030-0x00000031	Programmable interrupt controller
0x00000034-0x00000035	Programmable interrupt controller
0x00000038-0x00000039	Programmable interrupt controller
0x0000003C-0x0000003D	Programmable interrupt controller
0x000000A0-0x000000A1	Programmable interrupt controller
0x000000A4-0x000000A5	Programmable interrupt controller
0x000000A8-0x000000A9	Programmable interrupt controller
0x000000AC-0x000000AD	Programmable interrupt controller
0x000000B0-0x000000B1	Programmable interrupt controller
0x000000B4-0x000000B5	Programmable interrupt controller
0x000000B8-0x000000B9	Programmable interrupt controller
0x000000BC-0x000000BD	Programmable interrupt controller
0x000004D0-0x000004D1	Programmable interrupt controller
0x000003F8-0x000003FF	Communications Port (COM1)
0x000002F8-0x000002FF	Communications Port (COM2)
0x000003E8-0x000003EF	Communications Port (COM3)
0x00001854-0x00001857	Motherboard resources
0x0000C000-0x0000C0FF	Realtek PCIe GBE Family Controller
0x0000C000-0x0000C0FF	Intel(R) 100 Series/C230 Series Chipset Family PCI Express Root Port #5 - A114

Address	Device Description
0x00000000-0x00000CF7	PCI Express Root Complex
0x00000D00-0x0000FFFF	PCI Express Root Complex
0x000000F0-0x000000F0	Numeric data processor
0x0000FF00-0x0000FFFE	Motherboard resources
0x0000F000-0x0000F01F	Intel(R) 100 Series/C230 Series Chipset Family SMBus - A123
0x00000060-0x00000060	Standard PS/2 Keyboard
0x00000064-0x00000064	Standard PS/2 Keyboard
0x00000040-0x00000043	System timer
0x00000050-0x00000053	System timer
0x0000F050-0x0000F057	Standard SATA AHCI Controller
0x0000F040-0x0000F043	Standard SATA AHCI Controller
0x0000F020-0x0000F03F	Standard SATA AHCI Controller

C. Interrupt Request Lines (IRQ)

Peripheral devices use interrupt request lines to notify CPU for the service required. The following table shows the IRQ used by the devices on board.

Level	Function
IRQ 14	Motherboard resources
IRQ 4294967288	Realtek PCIe GBE Family Controller #2
IRQ 4294967294	Intel(R) Xeon(R) E3 - 1200/1500 v5/6th Gen Intel(R) Core(TM) PCIe Controller (x16) - 1901
IRQ 8	System CMOS/real time clock
IRQ 4	Communications Port (COM1)
IRQ 3	Communications Port (COM2)
IRQ 5	Communications Port (COM3)
IRQ 4294967287	Realtek PCIe GBE Family Controller
IRQ 54 ~ IRQ 204	Microsoft ACPI-Compliant System
IRQ 256 ~ IRQ 511	Microsoft ACPI-Compliant System
IRQ 4294967292	Intel(R) 100 Series/C230 Series Chipset Family PCI Express Root Port #5 - A114
IRQ 13	Numeric data processor
IRQ 17	High Definition Audio Controller
IRQ 4294967286	Intel(R) Management Engine Interface
IRQ 4294967289	Intel(R) USB 3.0 eXtensible Host Controller - 1.0 (Microsoft)
IRQ 11	Intel(R) 100 Series/C230 Series Chipset Family SMBus - A123
IRQ 11	Intel(R) 100 Series/C230 Series Chipset Family Thermal subsystem - A131
IRQ 1	Standard PS/2 Keyboard
IRQ 12	Microsoft PS/2 Mouse
IRQ 0	System timer
IRQ 16	High Definition Audio Controller
IRQ 4294967291	Standard SATA AHCI Controller
IRQ 4294967293	Intel(R) 100 Series/C230 Series Chipset Family PCI Express Root Port #4 - A113
IRQ 4294967290	AMD Radeon E8860

D. Watchdog Timer Configuration

The Watchdog Timer (WDT) is used to generate a variety of output signals after a user programmable count. The WDT is suitable for the use in the prevention of system lock-up, such as when software becomes trapped in a deadlock. Under these sorts of circumstances, the timer will count to zero and the selected outputs will be driven.

Under normal circumstance, you will need to restart the WDT at regular intervals before the timer counts to zero.

Sample Code:

```
//-----  
//  
// THIS CODE AND INFORMATION IS PROVIDED "AS IS" WITHOUT WARRANTY OF ANY  
// KIND, EITHER EXPRESSED OR IMPLIED, INCLUDING BUT NOT LIMITED TO THE  
// IMPLIED WARRANTIES OF MERCHANTABILITY AND/OR FITNESS FOR A PARTICULAR  
// PURPOSE.  
//  
//-----  
#include <dos.h>  
#include <conio.h>  
#include <stdio.h>  
#include <stdlib.h>  
#include "F81846.H"  
//-----  
int main (int argc, char *argv[]); void EnableWDT(int);  
void DisableWDT(void);  
//-----  
int main (int argc, char *argv[])  
{  
    unsigned char bBuf; unsigned char bTime; char **endptr;  
  
    char SIO;  
    printf("Fintek 81846 watch dog program\n"); SIO = Init_F81846();  
    if (SIO == 0)  
    {  
        printf("Can not detect Fintek 81846, program abort.\n"); return(1);  
    }/if (SIO == 0)  
  
    if (argc != 2)  
    {  
        printf(" Parameter incorrect!!\n"); return (1);  
    }  
  
    bTime = strtol (argv[1], endptr, 10);  
    printf("System will reset after %d seconds\n", bTime);  
  
    if (bTime)  
    {    EnableWDT(bTime); } else  
    {    DisableWDT(); } return 0;  
}
```

```

//-----
void EnableWDT(int interval)
{
unsigned char bBuf;

bBuf = Get_F81846_Reg(0x2B); bBuf &= (~0x20);
Set_F81846_Reg(0x2B, bBuf); //Enable WDTO

Set_F81846_LD(0x07); //switch to logic device 7
Set_F81846_Reg(0x30, 0x01); //enable timer

bBuf = Get_F81846_Reg(0xF5); bBuf &= (~0x0F);
bBuf |= 0x52;
Set_F81846_Reg(0xF5, bBuf); //count mode is second Set_F81846_Reg(0xF6,
interval); //set timer
bBuf = Get_F81846_Reg(0xFA); bBuf |= 0x01;
Set_F81846_Reg(0xFA, bBuf); //enable WDTO output

bBuf = Get_F81846_Reg(0xF5); bBuf |= 0x20;
Set_F81846_Reg(0xF5, bBuf); //start counting
}
//-----
void DisableWDT(void)
{
unsigned char bBuf;
Set_F81846_LD(0x07); //switch to logic device 7 bBuf = Get_F81846_Reg(0xFA);
bBuf &= ~0x01;
Set_F81846_Reg(0xFA, bBuf); //disable WDTO output

bBuf = Get_F81846_Reg(0xF5); bBuf &= ~0x20;
bBuf |= 0x40;
Set_F81846_Reg(0xF5, bBuf); //disable WDT
}
//-----

```

```
//-----  
//  
// THIS CODE AND INFORMATION IS PROVIDED "AS IS" WITHOUT WARRANTY OF ANY  
// KIND, EITHER EXPRESSED OR IMPLIED, INCLUDING BUT NOT LIMITED TO THE  
// IMPLIED WARRANTIES OF MERCHANTABILITY AND/OR FITNESS FOR A PARTICULAR  
// PURPOSE.  
//  
//-----  
#include "F81846.H"  
#include <dos.h>  
//-----  
unsigned int F81846_BASE; void Unlock_F81846 (void); void Lock_F81846 (void);  
//-----  
unsigned int Init_F81846(void)  
{  
    unsigned int result; unsigned char ucDid;  
  
    F81846_BASE = 0x4E;  
    result = F81846_BASE;  
  
    ucDid = Get_F81846_Reg(0x20);  
    if (ucDid == 0x07) //Fintek 81846  
    {    goto Init_Finish; }  
  
    F81846_BASE = 0x2E;  
    result = F81846_BASE;  
  
    ucDid = Get_F81846_Reg(0x20);  
    if (ucDid == 0x07) //Fintek 81846  
    {    goto Init_Finish; }  
  
    F81846_BASE = 0x00;  
    result = F81846_BASE;  
  
    Init_Finish:  
    return (result);  
}  
//-----  
void Unlock_F81846 (void)  
{  
    outportb(F81846_INDEX_PORT, F81846_UNLOCK); outportb(F81846_INDEX_PORT,  
    F81846_UNLOCK);  
}  
//-----  
void Lock_F81846 (void)  
{  
    outportb(F81846_INDEX_PORT, F81846_LOCK);  
}  
//-----  
void Set_F81846_LD( unsigned char LD)  
{  
    Unlock_F81846();  
    outportb(F81846_INDEX_PORT, F81846_REG_LD);  
    outportb(F81846_DATA_PORT, LD); Lock_F81846();  
}
```

```

}
//-----
void Set_F81846_Reg( unsigned char REG, unsigned char DATA)
{
Unlock_F81846(); outportb(F81846_INDEX_PORT, REG); outportb(F81846_DATA_PORT,
DATA); Lock_F81846();
}
//-----
unsigned char Get_F81846_Reg(unsigned char REG)
{
unsigned char Result; Unlock_F81846();
outportb(F81846_INDEX_PORT, REG); Result = inportb(F81846_DATA_PORT);
Lock_F81846();
return Result;
}
//-----

//-----
//
// THIS CODE AND INFORMATION IS PROVIDED "AS IS" WITHOUT WARRANTY OF ANY
// KIND, EITHER EXPRESSED OR IMPLIED, INCLUDING BUT NOT LIMITED TO THE
// IMPLIED WARRANTIES OF MERCHANTABILITY AND/OR FITNESS FOR A PARTICULAR
// PURPOSE.
//
//-----
#ifndef F81846_H
#define F81846_H 1
//-----
#define F81846_INDEX_PORT (F81846_BASE)
#define F81846_DATA_PORT (F81846_BASE+1)
//-----
#define F81846_REG_LD 0x07
//-----
#define F81846_UNLOCK 0x87
#define F81846_LOCK 0xAA
//-----
unsigned int Init_F81846(void);
void Set_F81846_LD( unsigned char);
void Set_F81846_Reg( unsigned char, unsigned char); unsigned char
Get_F81846_Reg( unsigned char);
//-----
#endif // F81846_H

```