

MPT-7000V

Multi-Purpose In-Vehicle System

User's Manual

Version 1.1
(Sep. 2018)



Copyright

© 2018 IBASE Technology, Inc. All rights reserved.

No part of this publication may be reproduced, copied, stored in a retrieval system, translated into any language or transmitted in any form or by any means, electronic, mechanical, photocopying, or otherwise, without the prior written consent of IBASE Technology, Inc. (hereinafter referred to as "IBASE").

Disclaimer

IBASE reserves the right to make changes and improvements to the products described in this document without prior notice. Every effort has been made to ensure the information in the document is correct; however, IBASE does not guarantee this document is error-free. IBASE assumes no liability for incidental or consequential damages arising from misapplication or inability to use the product or the information contained herein, nor for any infringements of rights of third parties, which may result from its use.

Trademarks

All the trademarks, registrations and brands mentioned herein are used for identification purposes only and may be trademarks and/or registered trademarks of their respective owners.

Compliance

CE

This product has passed CE tests for environmental specifications and limits. This product is in accordance with the directives of the Union European (EU). If users modify and/or install other devices in this equipment, the CE conformity declaration may no longer apply.

FCC

This product has been tested and found to comply with the limits for a Class B device, pursuant to Part 15 of the FCC Rules. These limits are designed to provide reasonable protection against harmful interference in a residential installation. This equipment generates, uses and can radiate radio frequency energy and, if not installed and used in accordance with manufacturer's instructions, may cause harmful interference to radio communications.

WEEE



This product must not be disposed of as normal household waste, in accordance with the EU directive of for waste electrical and electronic equipment (WEEE - 2012/19/EU). Instead, it should be disposed of by returning it to a municipal recycling collection point. Check local regulations for disposal of electronic products.

Green IBASE



This product is compliant with the current RoHS restrictions and prohibits use of the following substances in concentrations exceeding 0.1% by weight (1000 ppm) except for cadmium, limited to 0.01% by weight (100 ppm).

- Lead (Pb)
- Mercury (Hg)
- Cadmium (Cd)
- Hexavalent chromium (Cr6+)
- Polybrominated biphenyls (PBB)
- Polybrominated diphenyl ether (PBDE)

Important Safety Information

Carefully read the precautions before using the device.

Environmental conditions:

- Lay the device horizontally on a stable and solid surface in case the device may fall, causing serious damage.
- Leave plenty of space around the device and do not block the openings for ventilation. NEVER DROP OR INSERT ANY OBJECTS OF ANY KIND INTO THE VENTILATION OPENINGS.
- Slots and openings on the chassis are for ventilation. Do not block or cover these openings. Make sure you leave plenty of space around the device for ventilation. NEVER INSERT OBJECTS OF ANY KIND INTO THE VENTILATION OPENINGS.
- Use this product in environments with ambient temperatures between -30°C and 55°C for SSD.
- DO NOT LEAVE THIS DEVICE IN AN ENVIRONMENT WHERE THE STORAGE TEMPERATURE MAY GO BELOW -35°C OR ABOVE 85°C. This could damage the device. The device must be used in a controlled environment.

Care for your iBASE products:

- Before cleaning the device, turn it off and unplug all cables such as power in case a small amount of electrical current may still flow.
- Use neutral cleaning agents or diluted alcohol to clean the device chassis with a cloth. Then wipe the chassis with a dry cloth.
- Vacuum the dust with a computer vacuum cleaner to prevent the air vent or slots from being clogged.



WARNING

Attention during use:

- DO NOT connect a DC source to be used as the UPS voltage input. This could damage system. Refer to *2.1.8 Pinout for COM Ports, Power Input & GPIO Connectors* for information related to the DC power connectors and UPS battery connector.
- Do not use this product near water.
- Do not spill water or any other liquids on your device.
- Do not place heavy objects on the top of the device.
- Operate this device from the type of power indicated on the marking label. If you are not sure of the type of power available, consult your distributor or local power company.
- Do not walk on the power cord or allow anything to rest on it.
- If you use an extension cord, make sure that the total ampere rating of the product plugged into the extension cord does not exceed its limits.

Avoid Disassembly

You are not suggested to disassemble, repair or make any modification to the device. Disassembly, modification, or any attempt at repair could generate hazards and cause damage to the device, even bodily injury or property damage, and will void any warranty.



CAUTION

Danger of explosion if internal lithium-ion battery is replaced by an incorrect type. Replace only with the same or equivalent type recommended by the manufacturer. Dispose of used batteries according to the manufacturer's instructions.

Warranty Policy

- **IBASE standard products:**

24-month (2-year) warranty from the date of shipment. If the date of shipment cannot be ascertained, the product serial numbers can be used to determine the approximate shipping date.
- **3rd-party parts:**

12-month (1-year) warranty from delivery for the 3rd-party parts that are not manufactured by IBASE, such as CPU, memory, SSD/HDD, power adapter, panel and touchscreen.
- * PRODUCTS, HOWEVER, THAT FAILS DUE TO MISUSE, ACCIDENT, IMPROPER INSTALLATION OR UNAUTHORIZED REPAIR SHALL BE TREATED AS OUT OF WARRANTY AND CUSTOMERS SHALL BE BILLED FOR REPAIR AND SHIPPING CHARGES.

Technical Support & Services

1. Visit the IBASE website at www.ibase.com.tw to find the latest information about the product.
2. If you need any further assistance from your distributor or sales representative, prepare the following information of your product and elaborate upon the problem.
 - Product model name
 - Product serial number
 - Detailed description of the problem
 - The error messages in text or in screenshots if there is any
 - The arrangement of the peripherals
 - Software in use (such as OS and application software, including the version numbers)
3. If repair service is required, you can download the RMA form at <http://www.ibase.com.tw/english/Supports/RMAService/>. Fill out the form and contact your distributor or sales representative.

Table of Contents

Compliance.....	iii
Important Safety Information	iv
WARNING	iv
CAUTION	v
Warranty Policy.....	v
Technical Support & Services	v
Chapter 1 General Information.....	1
1.1 Introduction	2
1.2 Features.....	2
1.3 Packing List	3
1.4 Optional Accessories	3
1.5 Specifications.....	4
1.6 Overview.....	6
1.7 Device Dimensions	8
1.8 Fuse Dimensions	8
Chapter 2 Hardware Configuration	9
2.1 Essential Installations.....	10
2.1.1 Memory Installation	10
2.1.2 Storage Installation.....	12
2.1.3 CFast & Micro-SIM Card Installation.....	15
2.1.4 Mini-PCIe & M.2 Network Cards Installation	16
2.1.5 WiFi / 3G / 4G Antenna Installation.....	17
2.1.6 PCIe (x16) Expansion Card Installation	18
2.1.7 Mounting Brackets Installation	20
2.1.8 Pinout for COM Ports, Power Input & GPIO Connectors.....	22
2.2 Setting the Jumpers	24
2.2.1 How to Set Jumpers	24
2.3 Jumper & Connector Locations on Motherboard	25
2.4 Jumpers Quick Reference.....	27
2.4.1 COM1 & COM2 Voltage Selection (JP1, JP2).....	27
2.4.2 ME Register Clearance (J12).....	28
2.4.3 CMOS Data Clearance (J14)	28

2.4.4	Flash Descriptor Security Override Selection (J15)	29
2.5	Connectors Quick Reference	30
2.5.1	PCIe (x4) Slot (PCIE1)	31
2.5.2	Power Module Interface (PCIE2)	31
2.5.3	COM Port (COM1, COM2, COM3, COM4)	32
2.5.4	Digital I/O Connector (CN1)	32
2.5.5	DVI-D Port (CN2)	33
2.5.6	Audio Jack (CN6, CN15, CN16)	33
2.5.7	SATA III Connector (CN7, CN8)	33
2.5.8	CFast Connector (CN10)	34
2.5.9	USB 3.0 Ports (CN11, CN12)	34
2.5.10	SIM Card Slot (CN13, CN14)	34
2.5.11	GbE LAN Ports (CN3, CN4)	35
2.5.12	USB 2.0 Ports (CN5)	35
2.5.13	SATA HDD Power Connector (J4, J21)	35
2.5.14	CRT Connector (J5)	36
2.5.15	M.2 M2280 SATA Interface (J6)	36
2.5.16	M.2 E2230 USB2.0 / PCIe (x1) Interface (J8)	37
2.5.17	DDR4 SO-DIMM Socket (J9, J10)	37
2.5.18	Future Connector for CAN Module Connection (J11)	38
2.5.19	M.2 B3042 USB2.0 Interface (J17)	38
2.5.20	Half-Size Mini-PCIe USB2.0 Connector (J19)	39
2.5.21	Full-Size Mini-PCIe USB2.0 / PCIe (x1) Connector (J20)	39
2.5.22	Reset Button (SW2)	39
2.5.23	Digital IO Pull High to +5V Switch (SW1)	40
Chapter 3 Driver Installation		41
3.1	Introduction	42
3.2	Intel® Chipset Software Installation Utility	42
3.3	VGA Driver Installation	44
3.4	HD Audio Driver Installation	46
3.5	LAN Driver Installation	48
3.6	Intel® Management Engine Driver Installation	51
3.7	USB 3.0 Driver Installation	53
Chapter 4 BIOS Setup		55
4.1	Introduction	56
4.2	BIOS Setup	56
4.3	Main Settings	57
4.4	Advanced Settings	58
4.4.1	ACPI Settings	59

4.4.2	Power Board Configuration.....	60
4.4.3	Super IO Configuration	61
4.4.4	Hardware Monitor	67
4.4.5	NVMe Configuration	68
4.4.6	USB Configuration.....	68
4.4.7	CPU Configuration.....	70
4.4.8	SATA Configuration.....	71
4.4.9	CSM Configuration	72
4.5	Security Settings	73
4.6	Boot Settings.....	74
4.7	Save & Exit Settings.....	75
Appendix		76
A.	I/O Port Address Map.....	77
B.	Interrupt Request Lines (IRQ)	77
C.	Watchdog Timer Configuration.....	78
D.	Software Development Kit for WDT.DLL	82
E.	Motherboard MCU ISP Specifications	88

Chapter 1

General Information

The information provided in this chapter includes:

- Features
- Packing List
- Specifications
- Overview
- Dimensions

1.1 Introduction

The MPT-7000V is a vehicle-mounted product iBASE embedded computing system. It is a robust, rugged and fanless design with an Intel® Core™ i7/i3 processor and an Intel® I210 Ethernet controller. This product provides high-speed data transmission and reliable connection when subject to shock or vibration. It can be operated at the ambient operating temperature ranging from -40 ~ 70 °C if SSD is used, and even from -40 ~ 85 °C for storage.





1.2 Features

- In-vehicle fanless design box PC with E-mark
- Intel® Core™ i7/i3 processor and I210 Ethernet Controller
- Dual micro-SIM slots for WWAN redundancy
- Dual RJ45 Gigabit Ethernet ports
- Dual removable 2.5" drive bays and a CFast slot
- Rich I/O interfaces for wireless, SSD, GPS, WWAN and add-on card expansion
- Fully car battery power control
- Wide-range voltage GPIO interface
- One PCIe (x4) expansion

1.3 Packing List

Your MPT-7000V package should include the items listed below. If any of the items below is missing, contact the distributor or the dealer from whom you purchased the product.

Item	Q'ty	IBASE P/N
MPT-7000V	1	--
Mounting Bracket	2	--
DC-Input Connector (DINKLE terminal block, 3 pins)	1	C12165ESD03105200P
GPIO Matching Connector (DINKLE terminal block, 8 pins)	1	C1216EC3508103000P
Thermal Pad (35 x 20 x 1.5 mm) * Longer, for M.2 SSD module card	1	C1401035020150000P
Thermal Pad (20 x 20 x 5.5 mm) * Shorter, for M.2 WiFi module card	1	C1401020020055000P
Round Head Screw (1 for M.2 network Module Card, 1 for spare)	 2	H02306110122001N0P
Flat Head Screw for Mini PCIe Card	 2	H02203511122000N0P
Flat Head Screw (8 for SSD / HDD if not pre-installed, 4 for mounting brackets)	 12	H0230561B710BN000P

1.4 Optional Accessories

IBASE provide optional accessories as follows. Please contact us or your dealer if you need any.

Item	IBASE P/N
Thermal Pad (35 x 20 x 1.5 mm)	C1401035020150000P
Thermal Pad (20 x 20 x 5.5 mm)	C1401020020055000P
RTC Battery	C272113012020B100P
Fuse for MPT-7000V	C2309001151058000P
2.5" MLC SSD (64 GB)	A002SSDSA064G2524P
M.2 MLC SSD (128 GB)	A002SSDM2S128G200P
MLC CFast (8 GB)	A008CFG0080400200P

1.5 Specifications

Product Name	MPT-7000V
System	
Motherboard	MBT-7001V
Operating System	<ul style="list-style-type: none"> • Windows 10 (64-bit) • Windows Embedded Standard 7 (64-bit) • Linux Kernel 3.8.0 or above (64-bit)
CPU	<ul style="list-style-type: none"> • Intel® 6th Gen. Core™ i7-6600U processor at 2.6 GHz • Intel® 6th Gen. Core™ i3-6100U processor at 2.3 GHz
Cache	Level 2
Chipset	Integrated
Memory	2 x 4 GB DDR4-2133 SO-DIMM (default), upgradable to 32 GB (non-ECC)
Graphics	Intel® HD graphics Gen. 9 LP with up to 72 EUs
Network	2 x Intel® I210IT
Super I/O	Fintek F81866AD-I
Storage	2 x 2.5" SSD drive bay
Audio Codec	Realtek ALC662, two channels of input and output
Power Supply	9~36V with IGN control
Fuse	Littlefuse® TAC ATO® Style Blade 15A, 58V DC
RTC Battery	Panasonic BR2032 3V
BIOS	AMI BIOS
Watchdog	Watchdog Timer 256 segments, 0, 1, 2...255 sec/min
Chassis	Aluminum, black
Mounting	Custom mounting rail
Dimensions (W x H x D)	256 x 83 x 182 mm (10.08" x 3.27" x 7.17")
Net Weight	3.6 kg (7.94 lb)
Certificate	CE, FCC Class B, E-Mark
I/O Ports	
LAN	2 x GbE LAN
USB	<ul style="list-style-type: none"> • 2 x USB 3.0 • 2 x USB 2.0
SSD	2 x 2.5" drive bay
SATA	2 x SATA III ports

Serial	<p>3 x COM ports:</p> <ul style="list-style-type: none"> • COM1: RS-232/422/485 • COM2 & COM3: RS-232 only <p>* COM3 is optional with CAN.</p>
Display	<ul style="list-style-type: none"> • 1 x DVI-D, up to 1920 x 1080 • 1 x VGA, up to 1920 x 1080
Digital I/O	<p>6 In/Out with 24V input tolerance</p> <p>* You can use IBASE's software development kit (SDK) to configure GPIO in the operating system. For further information about the SDK, refer to Appendix D Software Development Kit for WDT.DLL in this manual.</p>
CFast	1 x CFast connector
SIM	2 x Micro-SIM card slot
Audio Jack	<ul style="list-style-type: none"> • 2 x Microphone Input • 2 x Line-out
Expansion	<ul style="list-style-type: none"> • 1 x Mini PCIe slot (full-sized) with USB 2.0 & PCIe • 1 x Mini PCIe slot (half-sized) with USB2.0 • 1 x M.2 slot (M2280) with SATA for SSD only • 1 x M.2 slot (E2230) with PCIe & USB for WLAN • 1 x M.2 slot (B3042) with PCIe & USB for WWAN
Environment	
Temperature	<ul style="list-style-type: none"> • Operating: SSD: -30 ~ 55 °C (-22 ~ 131 °F) SSD: -40 ~ 70 °C (-40 ~ 158 °F) if there is no card installed in the system • Storage: -35 ~ 85 °C (-31 ~ 185 °F)
Relative Humidity	10 ~ 95% (non-condensing)
Vibration Protection	<p>Operating / Non-operating:</p> <ul style="list-style-type: none"> • For SSD: 2.26 grms, 5 ~ 500 Hz (Z-axis) • For HDD: 1.04 grms, 5 ~ 500 Hz (Z-axis)
Shock Protection	<ul style="list-style-type: none"> • Operating: 20G, 11 msec (Z-axis) • Non-operating: 40G, 11 msec (Z-axis)

All specifications are subject to change without prior notice.

1.6 Overview

Front View



No.	Name	No.	Name
1	LED Indicators	5	USB 3.0 Receptacles
2	Reset Button	6	CFast / SIM Card Slot Door
3	Secondary Microphone Input	7	Antenna Holes
4	Secondary Line-out	8	SSD Drive Bays

Rear View

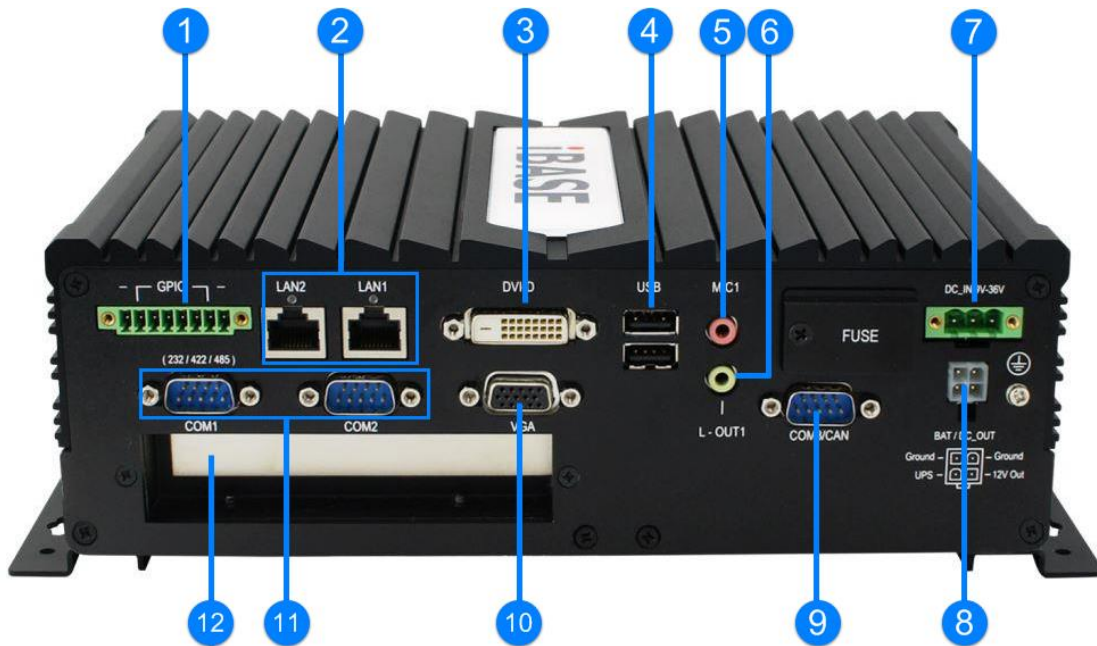

No.	Name	No.	Name
1	GPIO Connector	7	DC Input Connector
2	LAN Ports with LED Indicators	8	UPS Battery / DC 12V Output
3	DVI-D Port	9	COM3 / CAN (Optional)
4	USB 2.0 Ports	10	VGA Port
5	First Microphone Input	11	COM1 & COM2 Ports
6	First Line-out	12	Expansion Card Slot

Oblique View



1.7 Device Dimensions

Unit: mm

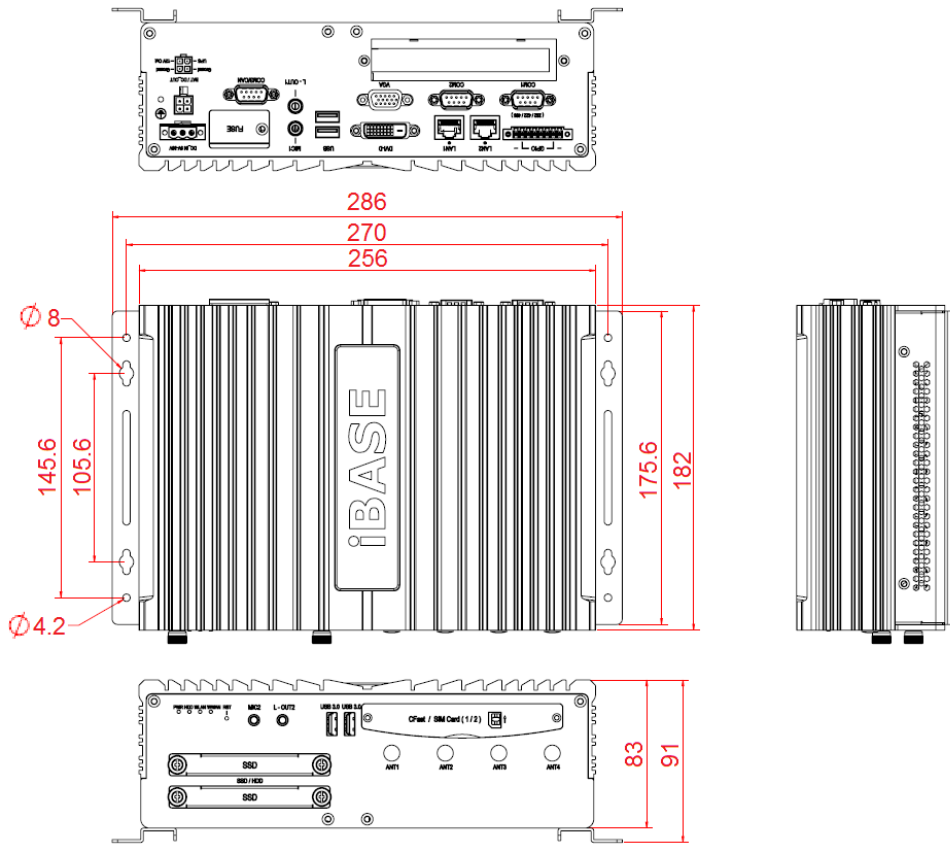

1.8 Fuse Dimensions

Littlefuse® TAC ATO® Style Blade 15A, 58V DC

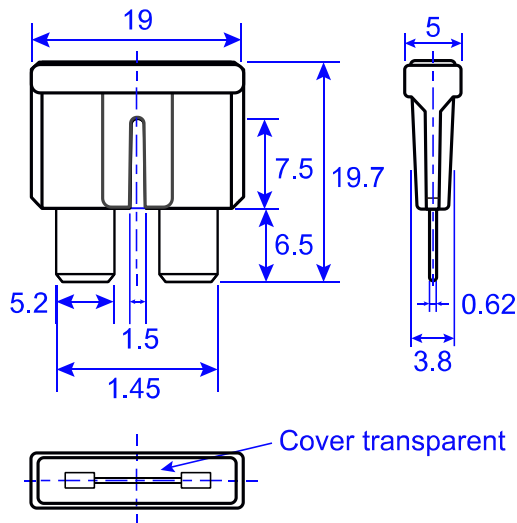

Chapter 2

Hardware Configuration

The information provided in this chapter includes:

- Essential installations
- Information and locations of connectors

2.1 Essential Installations

2.1.1 Memory Installation

If you need to replace or install the modules, perform the following steps:

1. Loosen the following 4 screws to pull out the SSD trays.

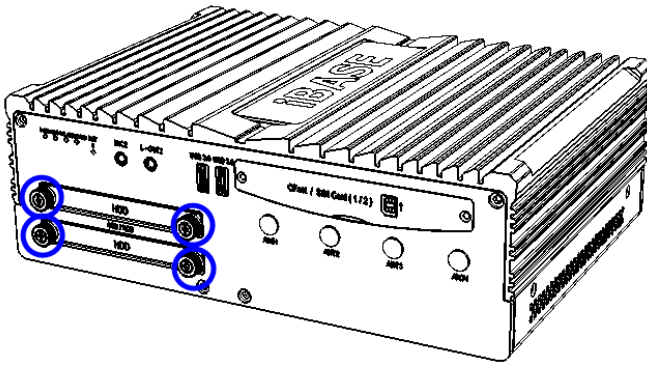

2. Turn your MPT-7000V upside down. Remove the following 4 screws to open the front I/O cover.

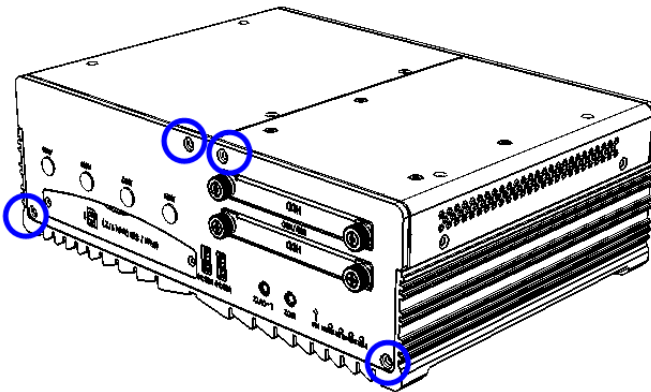

3. Release the following 6 screws to half open the bottom cover.

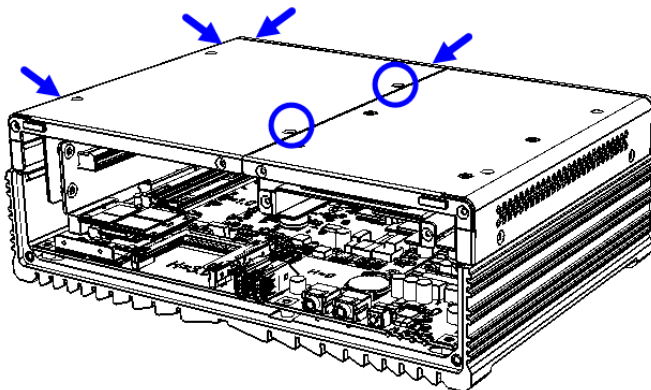

4. Locate the memory slot and align the keys of the memory module with that on the memory slot.
5. Insert the module slantwise and gently push the module straight down until the clips of the slot close to hold the module in place when the module touches the bottom of the slot.

To remove the module, press the clips outwards with both hands.

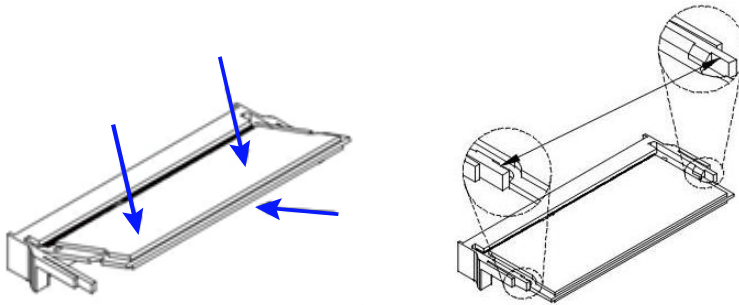

After installation, tighten the 8 screws mentioned in Step 2 to secure the device.

2.1.2 Storage Installation

You can use either SSD or M.2 SATA card, or use both for storage. For SSD or M.2 SATA card replacement or installation, follow the instructions below.

Installation for 2.5" SSD

1. Release 2 screws to pull out an SSD tray (4 screws for 2 trays).

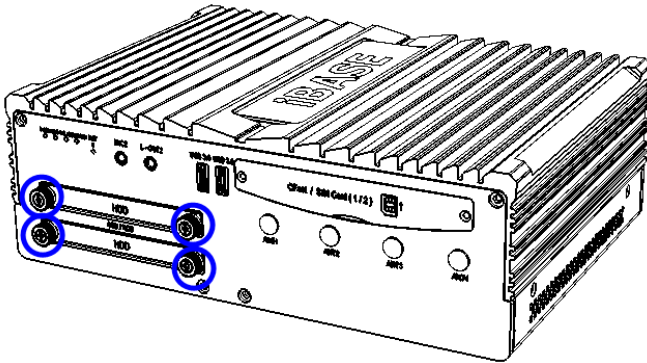

2. Put your 2.5" SSD onto the tray(s), and secure the SSD with the supplied 4 screws for each tray.

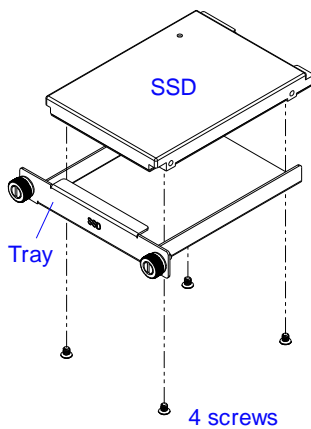

3. Put and secure the tray(s) back to the device.

Installation for M.2 SATA Card

1. Release the following 4 screws to pull out the SSD trays.

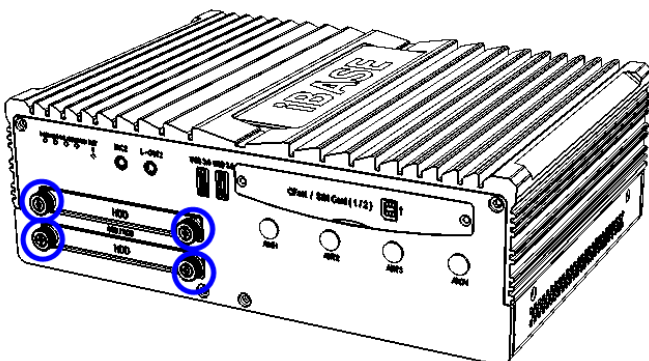

2. Turn your device upside down. Remove 4 screws to remove the front I/O cover.

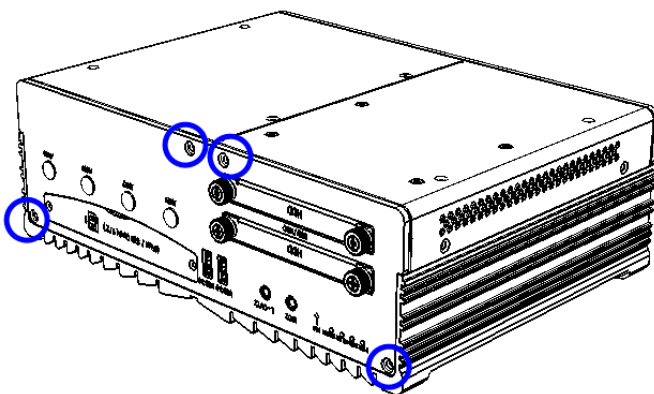

3. Remove the following 8 screws to open the whole bottom cover.

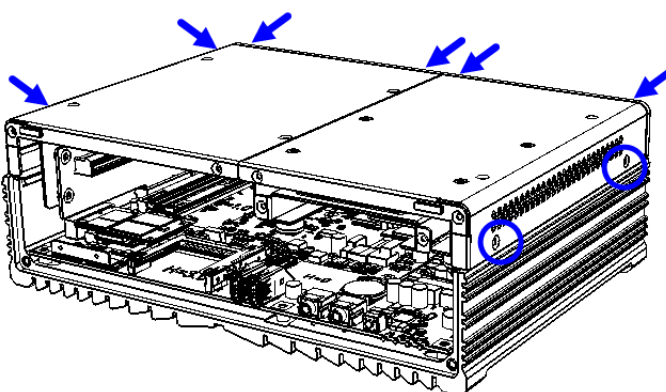

4. Install the M.2 SATA card .

- a.) Take out the heatsink by releasing 4 screws and remove the brass standoff.
- b.) Align the key of the M.2 card to the M.2 interface, and insert the card slantwise.

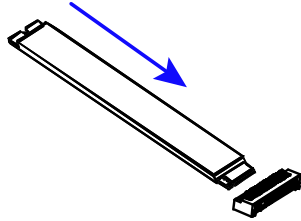

- c.) Push the M.2 card down and fix the card with the brass standoff you just released.
- d.) Put the supplied thermal pad (the thin one) onto the M.2 card and secure the heatsink back with 4 round head screws.

After installation, secure the bottom cover and front I/O cover and put back the SSD trays.

2.1.3 CFast & Micro-SIM Card Installation

1. Remove 2 screws as shown below to open the CFast & Micro-SIM card slot door.

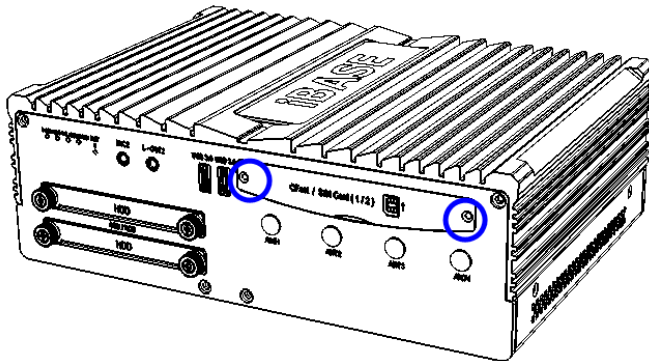

2. **For CFast card**, insert the card as below.
To remove the CFast card, push the card again.

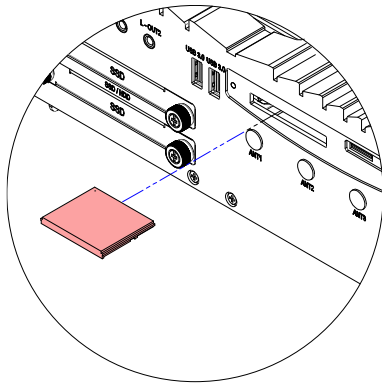

3. **For micro-SIM card**, insert the card to one of the micro-SIM card slot with the chip up and push the card by using your fingernail or a corner of the CFast & micro-SIM card door. Then refer to 2.1.4 *Mini-PCIe & M.2 Network Cards Installation* for further installation.

To remove the micro-SIM card, push the card again.

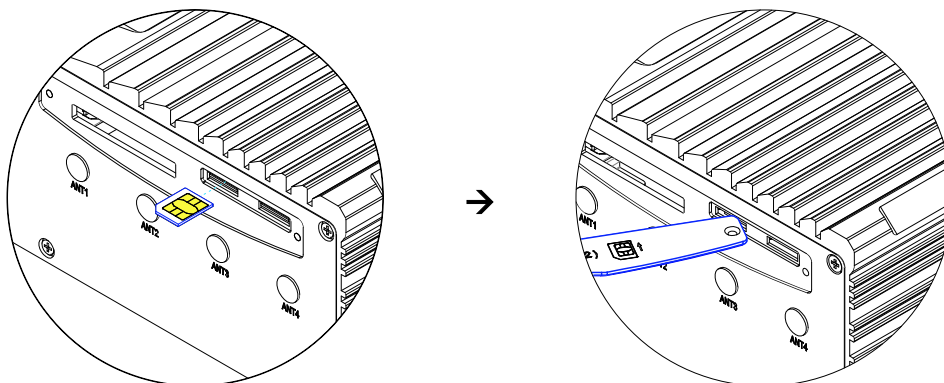

2.1.4 Mini-PCle & M.2 Network Cards Installation

Before installation, firstly pay attention to the interrelation among the micro-SIM card slots, mini-PCle slot, and M.2 slot as below.



For mini-PCle card installation, release the following 6 screws to half open the bottom cover after you remove the front I/O cover.

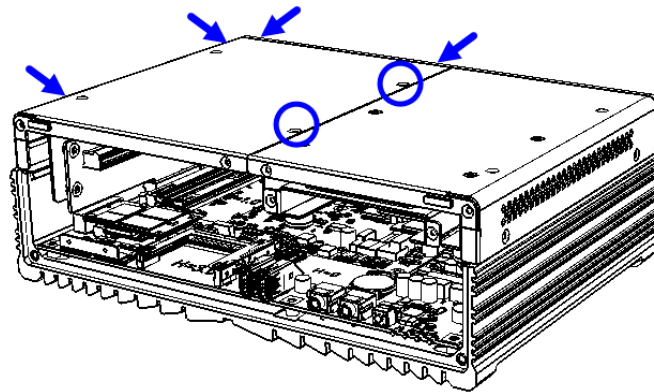

For M.2 card installation, you need to remove the whole bottom cover by referring to the section *Installation for M.2 SATA Card* in 2.1.2 *Storage Installation*. If the device is half open already, open the other half by removing 4 screws below.

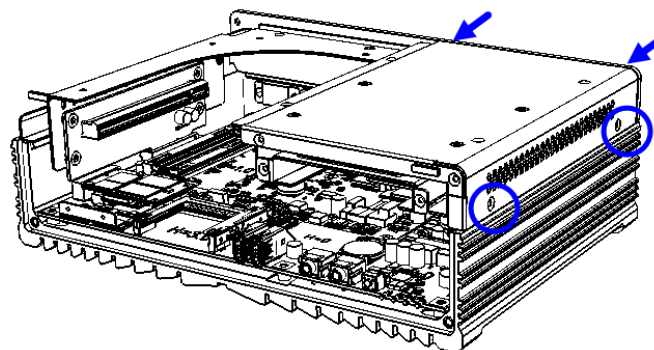

1. Locate the mini-PCIe slot, align the key of the mini-PCIe card to the interface, and insert the card slantwise.

(Insert the M.2 network card in the same way.)

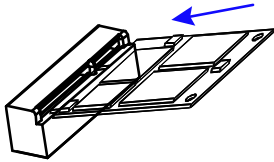

2. Push the mini-PCIe card down, fix it with the supplied 2 flat head screws for full-sized card and with one screw for half-sized card.

(Fix the M.2 network card with a supplied round head screw.)

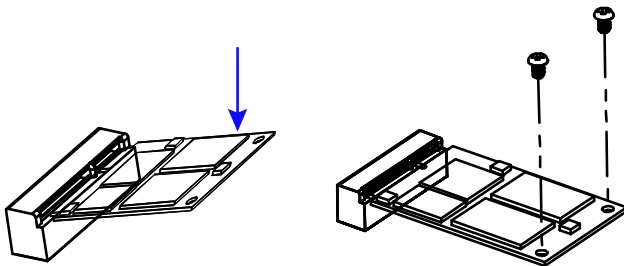

2.1.5 WiFi / 3G / 4G Antenna Installation

Thread the WiFi / 3G / 4G antenna extension cable through an antenna hole of the front I/O cover and fasten the antenna as shown below. Then apply adhesive to the edge of the hex nut behind the front I/O cover to prevent the extension cable from falling if the cable becomes loose.

1. Thread and fasten the hex nut and the washer. Then install the antenna.

2. Apply adhesive around here.



Info: The diameter of the nut is around 6.35 mm (0.25"-36UNC).

2.1.6 PCIe (x16) Expansion Card Installation

1. Remove the following 6 screws to half open the bottom cover after you remove the front I/O cover.

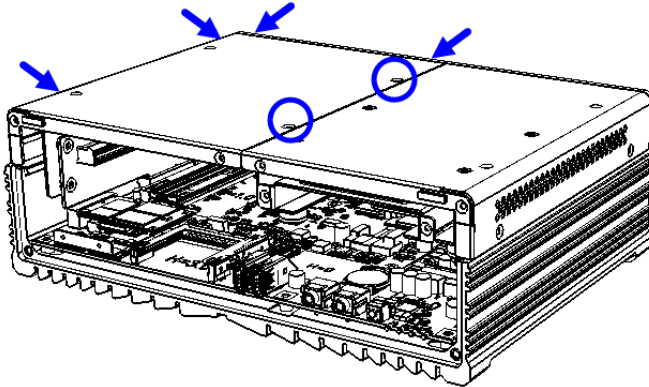

2. Remove 2 screws on the rear I/O cover to take out the PCIe expansion bracket. Then remove a screw to separate the PCIe expansion bracket and its shield.

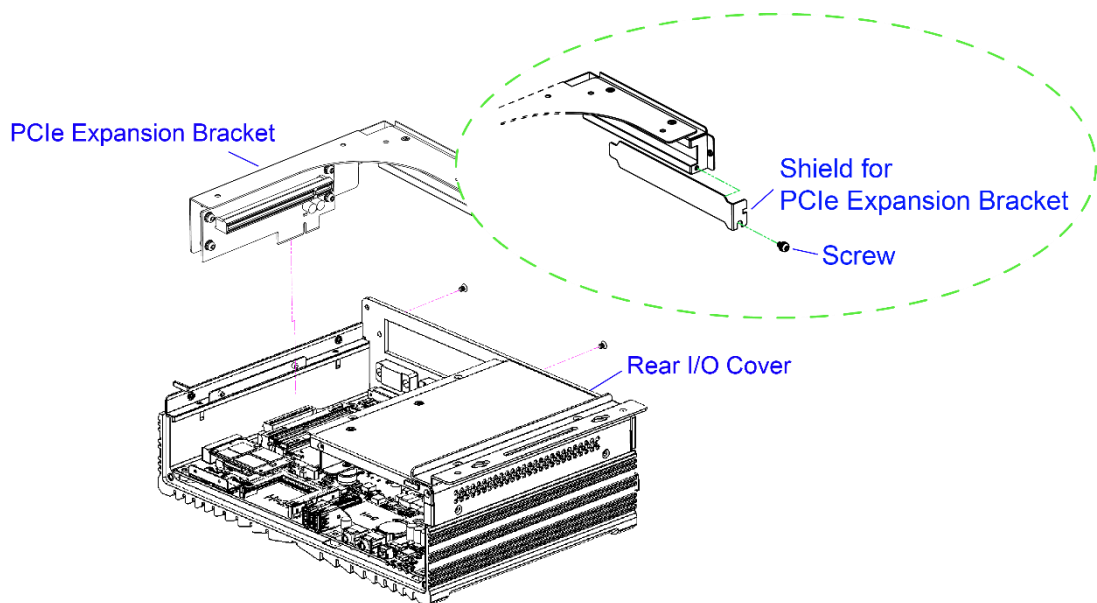

3. Install the PCIe (x16) expansion card and fix the card to the bracket by tightening the screw as below.

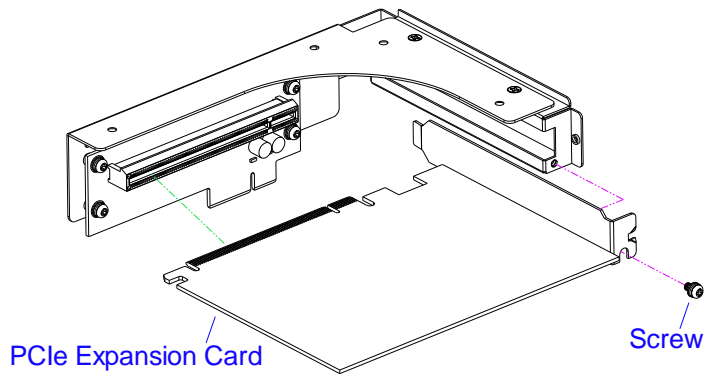

4. Install the bracket with the card back to the device and tighten 2 screws on the rear I/O cover to fix the bracket.

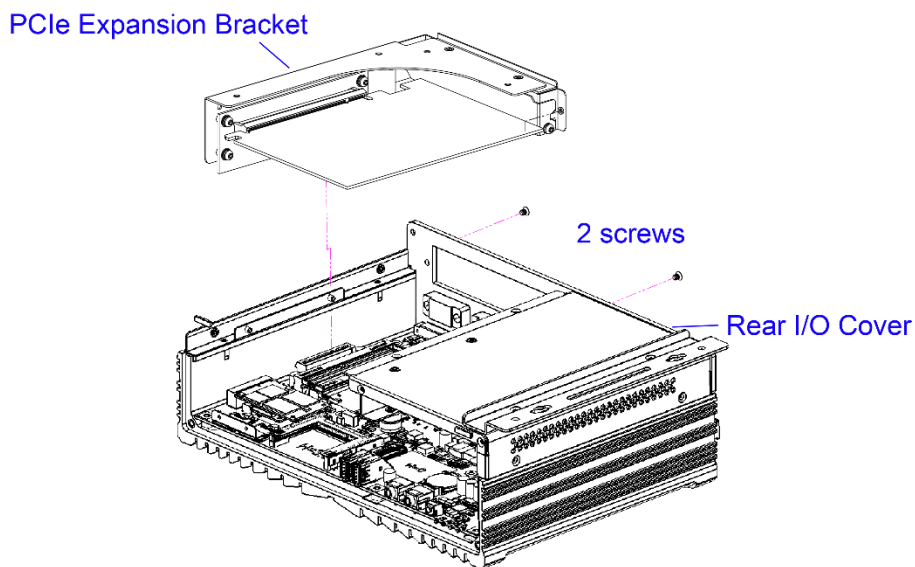

After installation, tighten 7 screws mentioned in Step 1 to secure the half bottom cover.

2.1.7 Mounting Brackets Installation

Note: Before mounting the system on wall, ensure that you are following all applicable building and electric codes.

Requirements

When mounting, ensure that you have enough room for power and signal cable routing. And have good ventilation for power adapter. The method of mounting must be able to support weight of the MPT-7000V plus the suspend weight of all the cables to be attached to the system. Use the following methods for mounting your system:

Selecting the Location

Plan the mounting location thoroughly. Locations such as walkway areas, hallways, and crowded areas are not recommended. Mount the product to a flat, sturdy, structurally sound column or wall surface.

The best mounting surface is a standard countertop, cabinet, table, or other structure that is minimally the width and length of the product. This will reduce the risk that someone may accidentally wall into and damage the product. Local laws governing the safety of individuals might require this type of consideration.

Selecting the type of wall construction

1. Mounting on a hollow wall

- **Wood surface**

Use construction-grade wood and the recommended minimum thickness is 38 x 25.4 mm (1.5" x 10").

Note: This method provides the most reliable attachment for the product with little risk that the product may come loose or require ongoing maintenance.

- **Drywall**

Drywall over wood studs is acceptable.

2. Mounting on a solid concrete or brick wall with flat and smooth surface

Installation instructions:

1. Turn your MPT-7000V upside down, attach the mounting brackets to MPT-7000V, and secure with the supplied 4 screws as below.

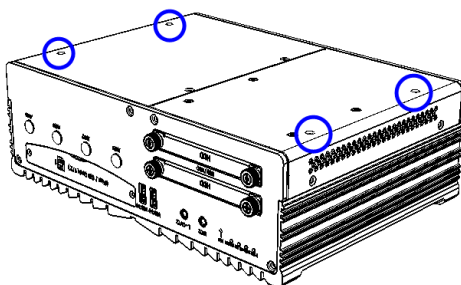

2. Prepare at least 4 screws (M3, 6 mm) to mount MPT-7000V on wall .

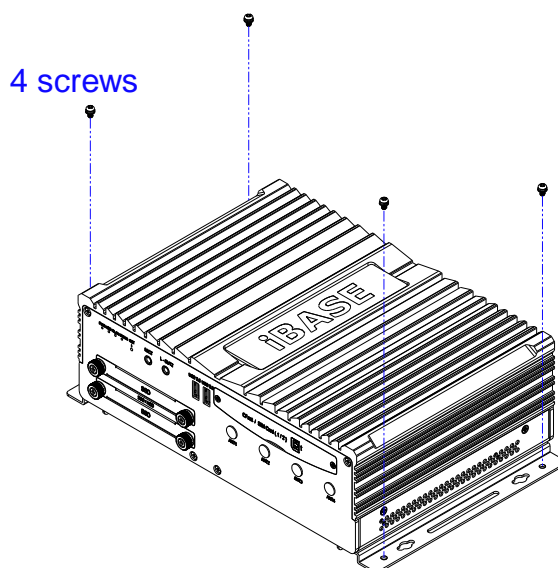

You can install MPT-7000V on plastic (LCD monitor), wood, drywall surface over studs, or a solid concrete or metal plane directly. The types of fasteners required are dependent on the type of wall construction.

Fasteners are not supplied in the product package. You will need to prepare the fasteners. Choose fasteners that are rated either **Medium Duty** or **Heavy Duty**. To assure proper fastener selection and installation, follow the fastener manufacturer's recommendations.

2.1.8 Pinout for COM Ports, Power Input & GPIO Connectors

- COM1 RS232/422/485 Port**

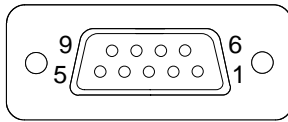

Pin	Assignment	Pin	Assignment
1	DCD, Data carrier detect	6	DSR, Data set ready
2	RXD, Receive data	7	RTS, Request to send
3	TXD, Transmit data	8	CTS, Clear to send
4	DTR, Data terminal ready	9	RI, Ring indicator
5	Ground		

Pin	Assignment		
	RS-232	RS-422	RS-485
1	DCD	TX-	DATA-
2	RX	TX+	DATA+
3	TX	RX+	NC
4	DTR	RX-	NC
5	Ground	Ground	Ground
6	DSR	NC	NC
7	RTS	NC	NC
8	CTS	NC	NC
9	RI	NC	NC

- COM2 / COM3 RS-232 Ports**

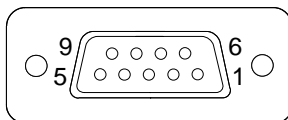

Pin	Assignment	Pin	Assignment
1	DCD, Data carrier detect	6	DSR, Data set ready
2	RXD, Receive data	7	RTS, Request to send
3	TXD, Transmit data	8	CTS, Clear to send
4	DTR, Data terminal ready	9	RI, Ring indicator
5	Ground		

- **DC Power 9 ~ 36V Input Connector (Terminal Block)**

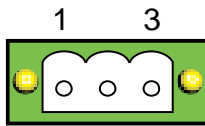

The system is designed for vehicle application powered by a battery. To prevent the car battery from being damaged at the system startup, a protection scheme that the input voltage level should be above 12.5V is designed for the system.

If you would like to run the system without the protection scheme (the input voltage level higher than 12.5V), please contact your distributor or sales representative.

Pin	Assignment	Pin	Assignment
1	Ignition	3	Ground
2	DC-Input		

- **UPS Battery / DC Power 12V Output Connector (ATX Jack)**

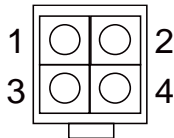

Make sure the UPS battery voltage level is above 12.5V before using the battery in order to prolong the life of the UPS battery.

Use only lead-acid batteries for the system.

DO NOT connect a DC source to be used as the UPS voltage input. This could damage the system. This connector has a charging feature.

Pin	Assignment	Pin	Assignment
1	Ground	2	Ground
3	UPS	4	12V Out

- **GPIO Connector (terminal block)**

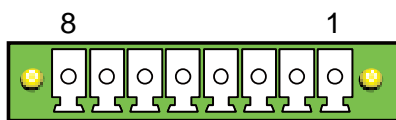

Pin	Assignment	Pin	Assignment
1	Ground	5	DIO4
2	DIO1	6	DIO5
3	DIO2	7	DIO6
4	DIO3	8	Ground

2.2 Setting the Jumpers

Set up and configure your device by using jumpers for various settings and features according to your needs and applications. Contact your supplier if you have doubts about the best configuration for your use.

2.2.1 How to Set Jumpers

Jumpers are short-length conductors consisting of several metal pins with a non-conductive base mounted on the circuit board. Jumper caps are used to have the functions and features enabled or disabled. If a jumper has 3 pins, you can connect either PIN1 to PIN2 or PIN2 to PIN3 by shorting.

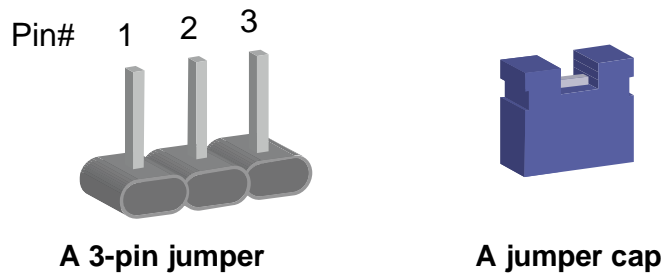

Refer to the illustration below to set jumpers.

Pin closed	Oblique view	Schematic illustration in the manual
Open		
1-2		
2-3		

When two pins of a jumper are encased in a jumper cap, this jumper is **closed**, i.e. turned **On**.

When a jumper cap is removed from two jumper pins, this jumper is **open**, i.e. turned **Off**.

2.3 Jumper & Connector Locations on Motherboard

Motherboard: MBT-7001V

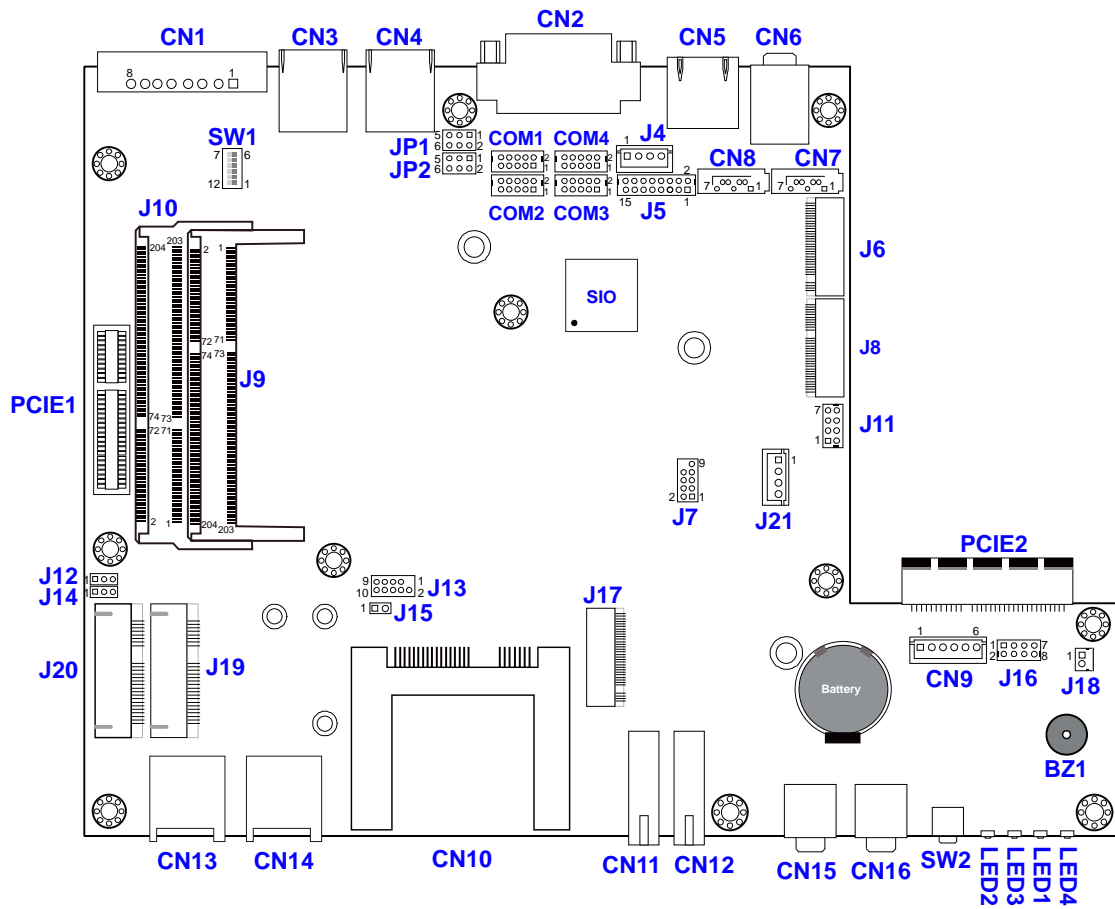

MBT-7001V - top

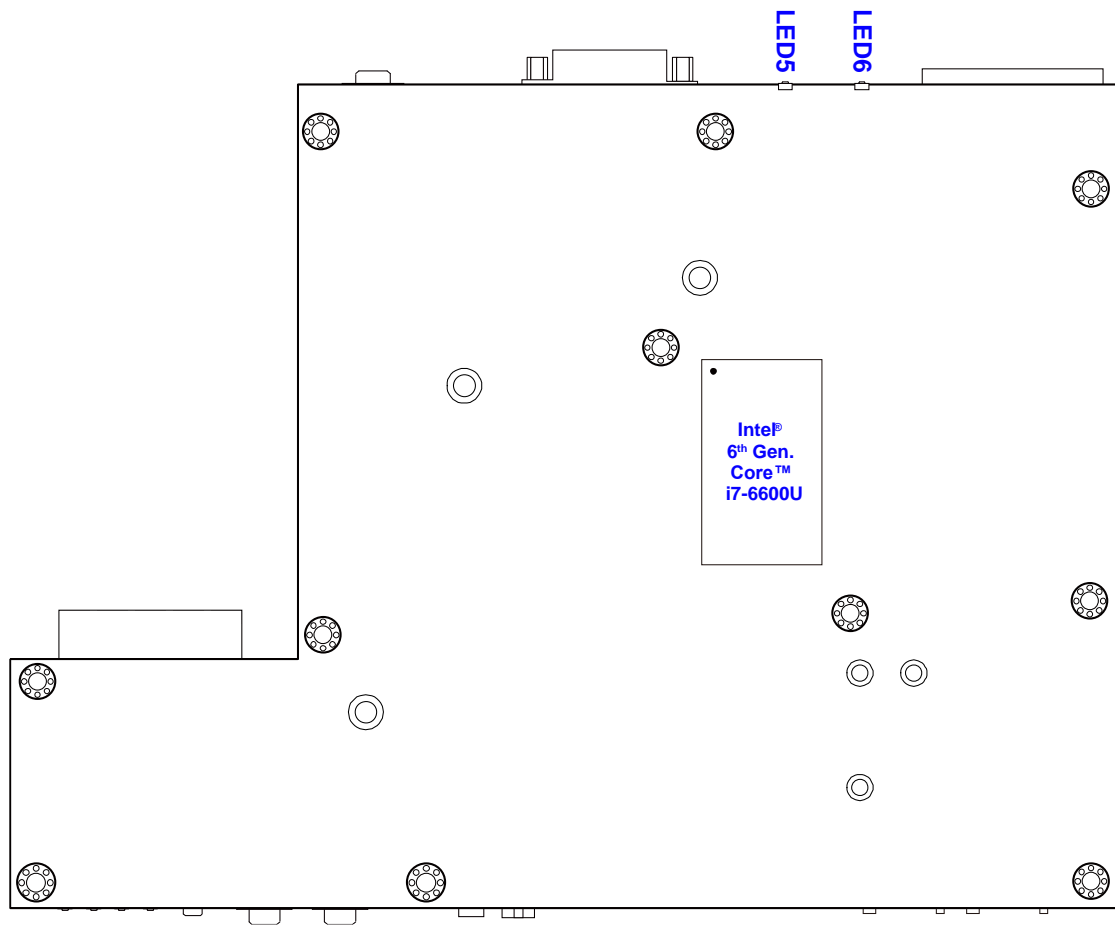

MBT-7001V - bottom

2.4 Jumpers Quick Reference

Function	Connector Name	Page
COM1 & COM2 Voltage Selection	JP1, JP2	27
ME Register Clearance	J12	28
CMOS Data Clearance	J14	28
Flash Descriptor Security Override Selection	J15	29

2.4.1 COM1 & COM2 Voltage Selection (JP1, JP2)

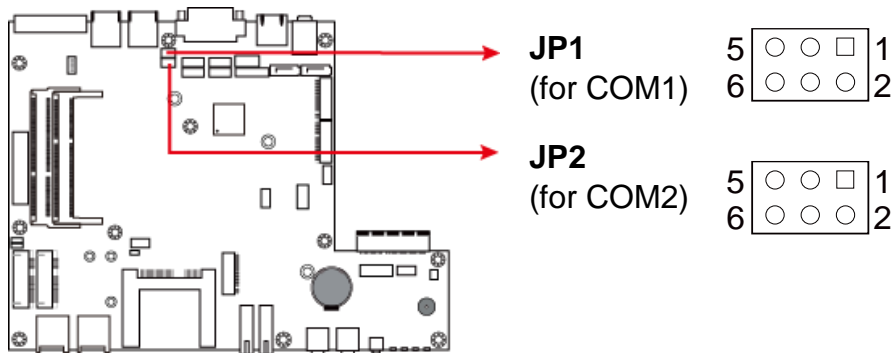

Function	Pin closed	Illustration										
12V	1-3	<table border="1"> <tr> <td>5</td> <td>○</td> <td>●</td> <td>□</td> <td>1</td> </tr> <tr> <td>6</td> <td>○</td> <td>○</td> <td>○</td> <td>2</td> </tr> </table>	5	○	●	□	1	6	○	○	○	2
5	○	●	□	1								
6	○	○	○	2								
RI (default)	3-4	<table border="1"> <tr> <td>5</td> <td>○</td> <td>○</td> <td>□</td> <td>1</td> </tr> <tr> <td>6</td> <td>○</td> <td>●</td> <td>○</td> <td>2</td> </tr> </table>	5	○	○	□	1	6	○	●	○	2
5	○	○	□	1								
6	○	●	○	2								
5V	3-5	<table border="1"> <tr> <td>5</td> <td>○</td> <td>○</td> <td>□</td> <td>1</td> </tr> <tr> <td>6</td> <td>○</td> <td>○</td> <td>○</td> <td>2</td> </tr> </table>	5	○	○	□	1	6	○	○	○	2
5	○	○	□	1								
6	○	○	○	2								

2.4.2 ME Register Clearance (J12)

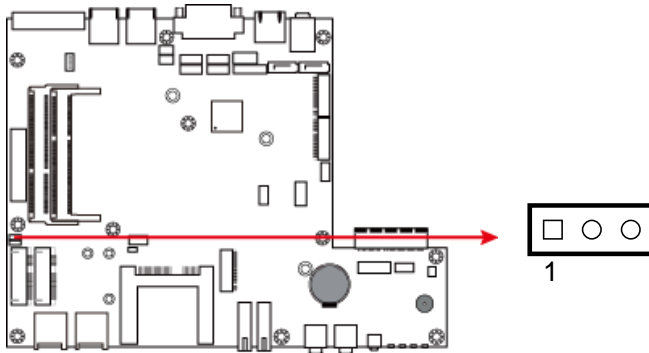

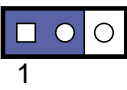
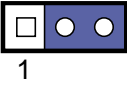
Function	Pin closed	Illustration
Normal (default)	1-2	
Clear ME Register	2-3	

2.4.3 CMOS Data Clearance (J14)

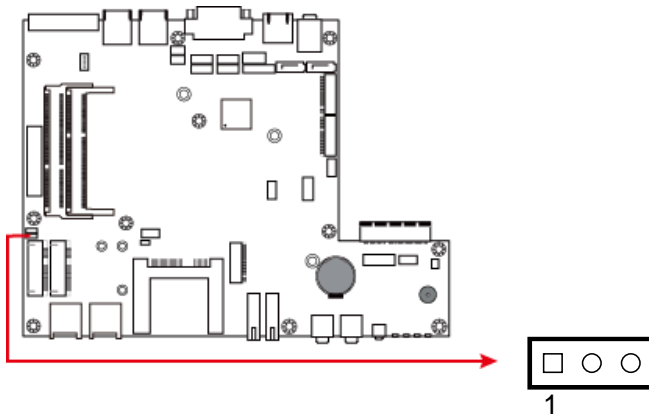

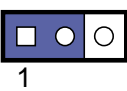
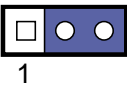
Function	Pin closed	Illustration
Normal (default)	1-2	
Clear CMOS	2-3	

2.4.4 Flash Descriptor Security Override Selection (J15)

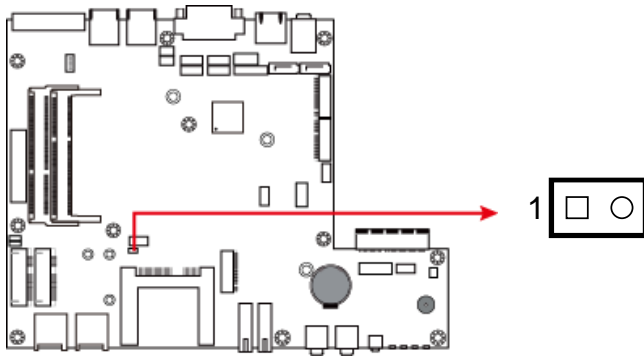

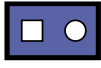
Function	Pin closed	Illustration
No override (default)	Open	1 
Override	Close	1 

2.5 Connectors Quick Reference

Function	Connector Name	Page
PCIe (x4) Slot	PCIE1	31
DC Power Input 12V Connector	PCIE2	31
COM Port	COM1, COM2, COM3, COM4	32
Digital I/O Connector	CN1	32
DVI-D Port	CN2	33
Audio Jacks	CN6 (system rear), CN15, CN16 (system front)	33
SATA III Connector	CN7, CN8	33
CFast Connector	CN10	34
USB 3.0 Port	CN11, CN12	34
SIM Card Slot	CN13 (interrelated with J20), CN14 (interrelated with J17)	34
GbE LAN Port	J1, J2	35
USB 2.0 Port	J3	35
SATA HDD Power Connector	J4, J21	35
CRT Connector	J5	36
M.2 M2280 SATA Interface	J6	36
M.2 E2230 USB2.0 / PCIe (x1) Interface	J8	37
DDR4 SO-DIMM Socket	J9 (channel A), J10 (channel B)	37
Future Connector for CAN Module Connection	J11	38
M.2 B3042 USB2.0 Interface	J17 (interrelated with CN14)	38
Half-Size Mini-PCIe USB2.0 Connector	J19	39
Full-Size Mini-PCIe USB2.0 / PCIe (x1) Connector	J20 (interrelated with CN13)	39
Reset Button	SW2	39
Digital IO Pull High to +5V Switch	SW1	40

Function	Connector Name	Page
LED Indicators	LED1 (for storage, white), LED2 (for WWAN, amber) LED3 (for WLAN, blue) LED4 (for MB Power, green) LED5 (for LAN, green) LED6 (for LAN, green)	--
Power Board +12V Connector (Reserved)	CN9	--
Power Connector (Reserved)	J16	--
Motherboard Power Button Connector	J18	--
Factory Use Only	J7, J13	--

2.5.1 PCIe (x4) Slot (PCIE1)

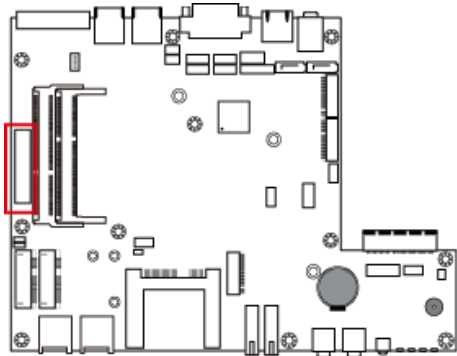

2.5.2 Power Module Interface (PCIE2)

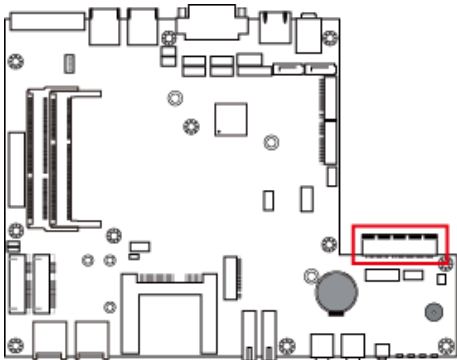

2.5.3 COM Port (COM1, COM2, COM3, COM4)

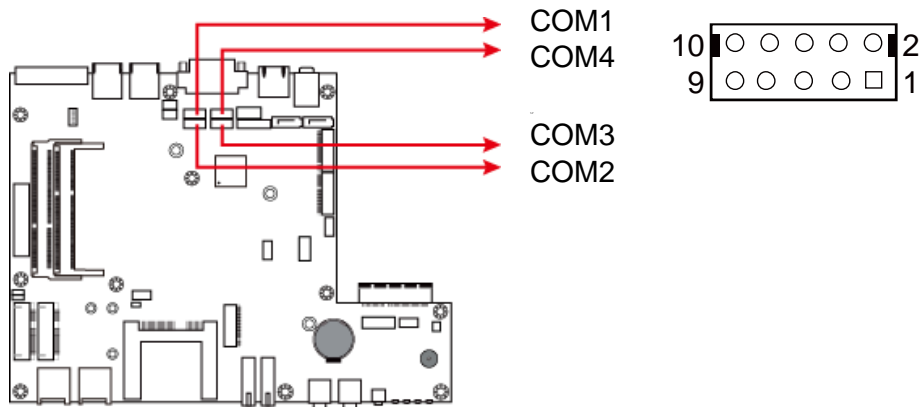

Pin	Assignment	Pin	Assignment
1	DCD	2	RXD
3	TXD	4	DTR
5	Ground	6	DSR
7	RTS	8	CTS
9	RI	10	NC

2.5.4 Digital I/O Connector (CN1)

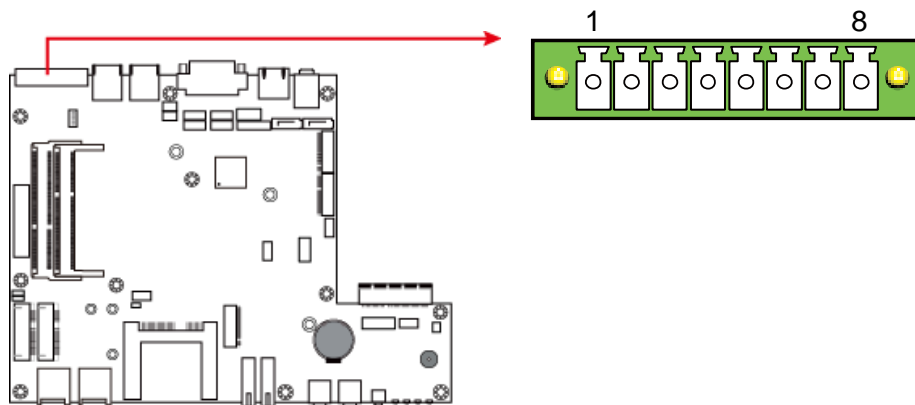

Pin	Assignment	Pin	Assignment
1	Ground	5	DIO4
2	DIO1	6	DIO5
3	DIO2	7	DIO6
4	DIO3	8	Ground

2.5.5 DVI-D Port (CN2)

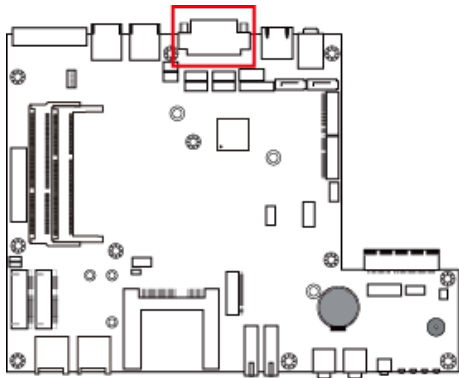

2.5.6 Audio Jack (CN6, CN15, CN16)

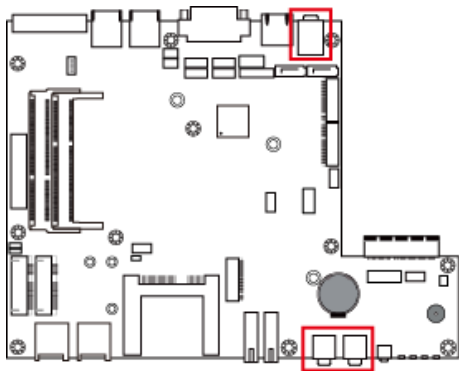

2.5.7 SATA III Connector (CN7, CN8)

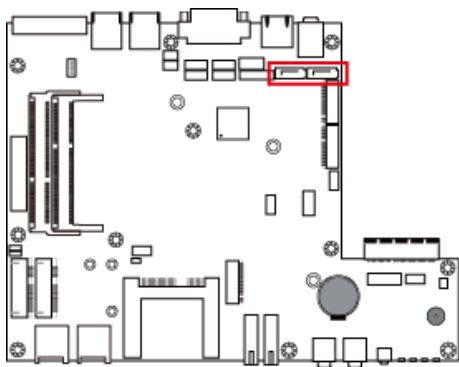

2.5.8 CFast Connector (CN10)

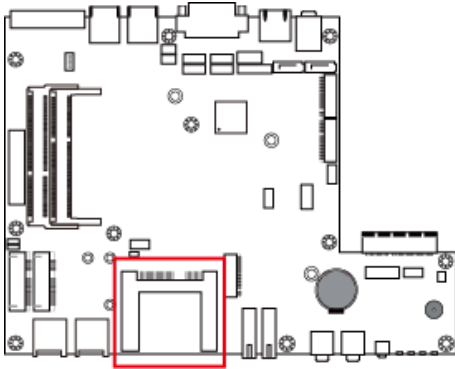

2.5.9 USB 3.0 Ports (CN11, CN12)

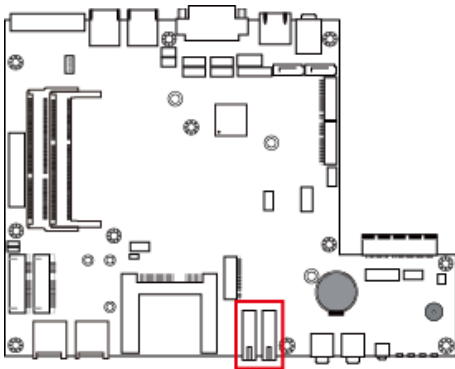

2.5.10 SIM Card Slot (CN13, CN14)

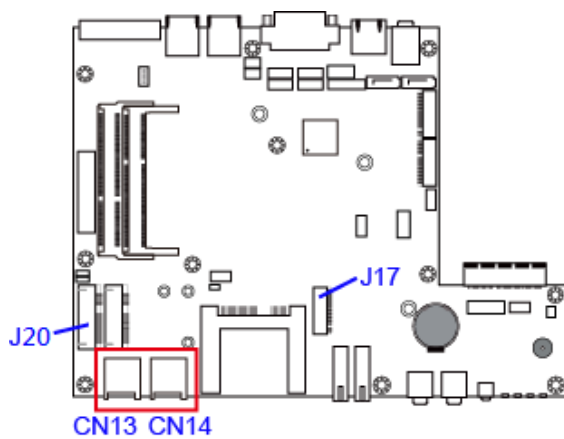

CN13 is interrelated with the mini-PCIe slot J20.
CN14 is interrelated with the M.2 slot J17.

2.5.11 GbE LAN Ports (CN3, CN4)

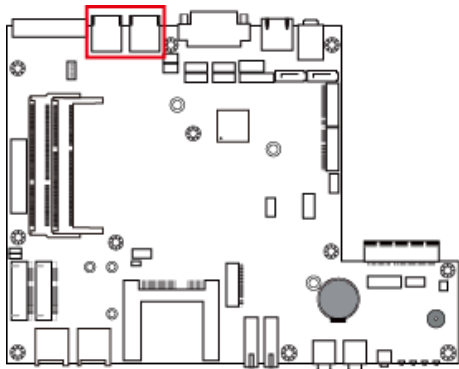

2.5.12 USB 2.0 Ports (CN5)

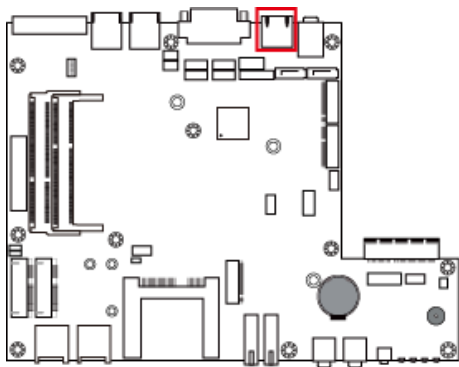

2.5.13 SATA HDD Power Connector (J4, J21)

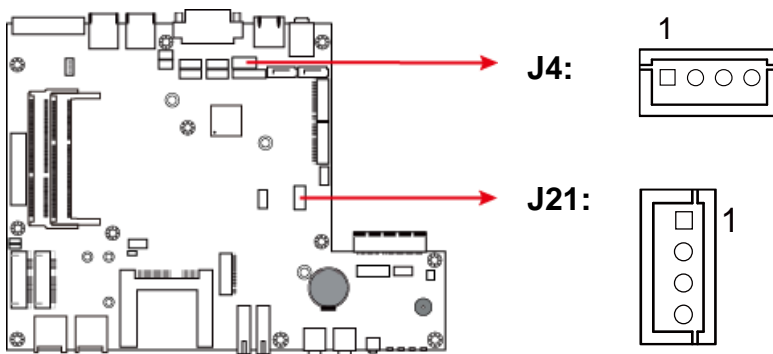

Pin	Assignment	Pin	Assignment
1	+5V	3	Ground
2	Ground	4	+12V

2.5.14 CRT Connector (J5)

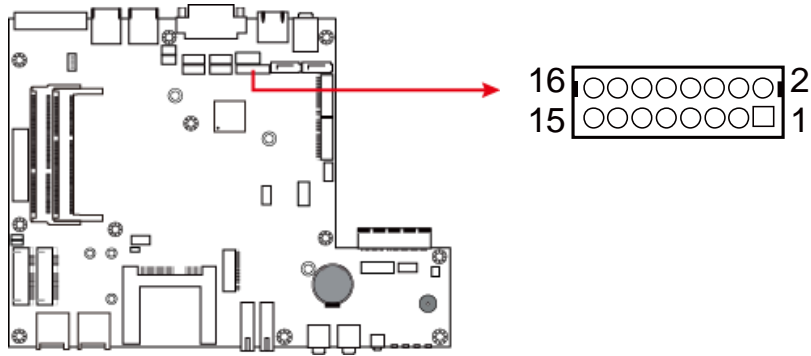

Pin	Assignment	Pin	Assignment
1	Red	2	VCC
3	Green	4	Ground
5	Blue	6	NC
7	NC	8	DDCDATA
9	Ground	10	HSYNC
11	Ground	12	VSYNC
13	Ground	14	DDCCLK
15	Ground	16	NC

2.5.15 M.2 M2280 SATA Interface (J6)

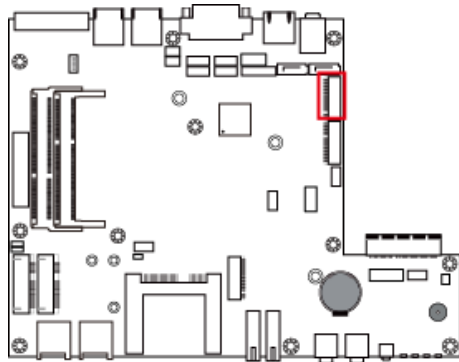

2.5.16 M.2 E2230 USB2.0 / PCIe (x1) Interface (J8)

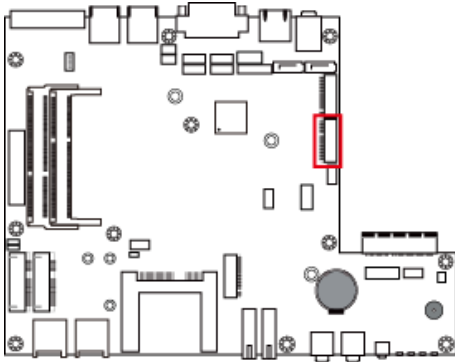

2.5.17 DDR4 SO-DIMM Socket (J9, J10)

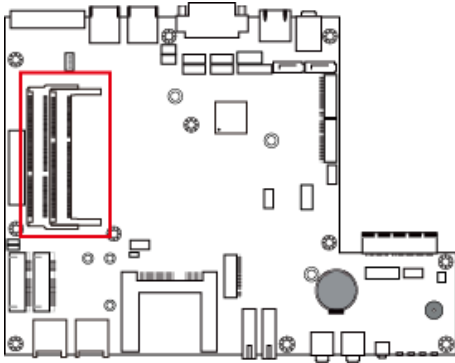

2.5.18 Future Connector for CAN Module Connection (J11)

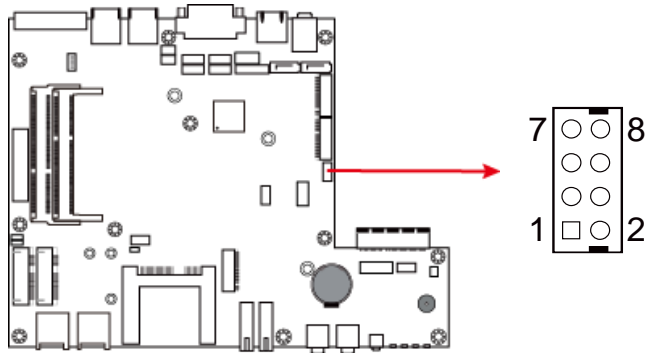

Pin	Assignment	Pin	Assignment
1	+5V	2	Ground
3	USB-	4	COM6_TX
5	USB+	6	COM6_RX
7	Ground	8	+5V

2.5.19 M.2 B3042 USB2.0 Interface (J17)

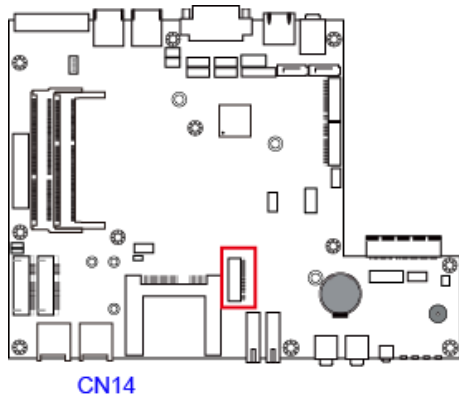

J17 is interrelated with the SIM card slot CN14.

2.5.20 Half-Size Mini-PCle USB2.0 Connector (J19)

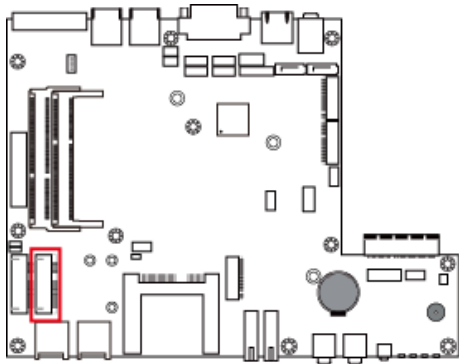

2.5.21 Full-Size Mini-PCle USB2.0 / PCIe (x1) Connector (J20)

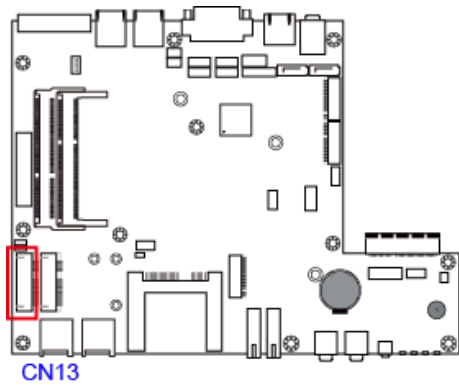

J20 is interrelated with the SIM card slot CN13.

2.5.22 Reset Button (SW2)

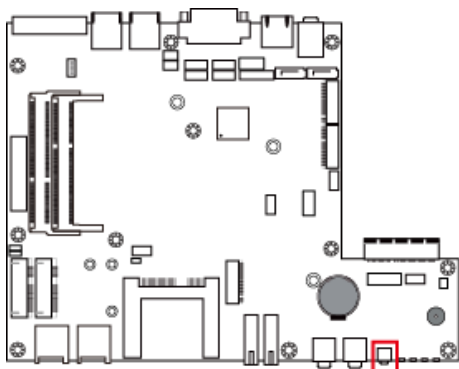

2.5.23 Digital IO Pull High to +5V Switch (SW1)

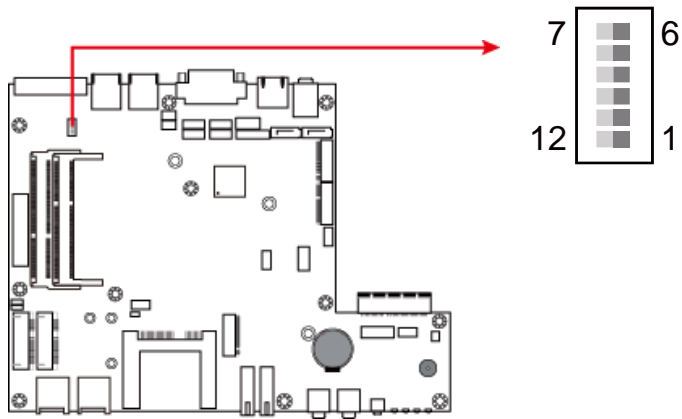

Switch to **ON** to pull high to 5V.

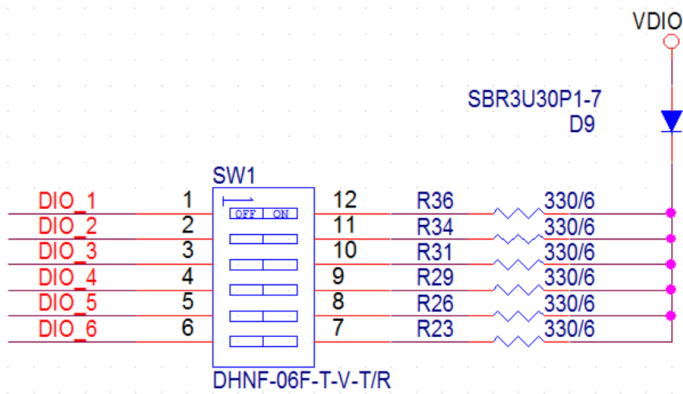

Pin	Assignment	Pin	Assignment
1	DIO1	7	5V
2	DIO2	8	5V
3	DIO3	9	5V
4	DIO4	10	5V
5	DIO5	11	5V
6	DIO6	12	5V

Chapter 3

Driver Installation

The information provided in this chapter includes:

- Intel® Chipset Software Installation Utility
- VGA Driver Installation
- HD Audio Driver Installation
- LAN Driver Installation
- Intel® Management Engine Driver Installation
- USB 3.0 Driver Installation

3.1 Introduction

This section describes the installation procedures for software drivers.

Note: After installing your Windows operating system, you must install the Intel® Chipset Software Installation Utility first before proceeding with the drivers installation.

3.2 Intel® Chipset Software Installation Utility

The Intel® Chipset drivers should be installed first before the software drivers to install INF files for Plug & Play function for the chipset components. Follow the instructions below to complete the installation.

1. Go to the download page of the product. Copy the compressed drivers file to your computer. Double click the file to decompress it. Run “CDGuide” to go to the main drivers page as shown. Click **Intel** and then **Intel(R) Skylake-U Chipset Drivers**.



2. Click **Intel(R) Chipset Software Installation Utility**.

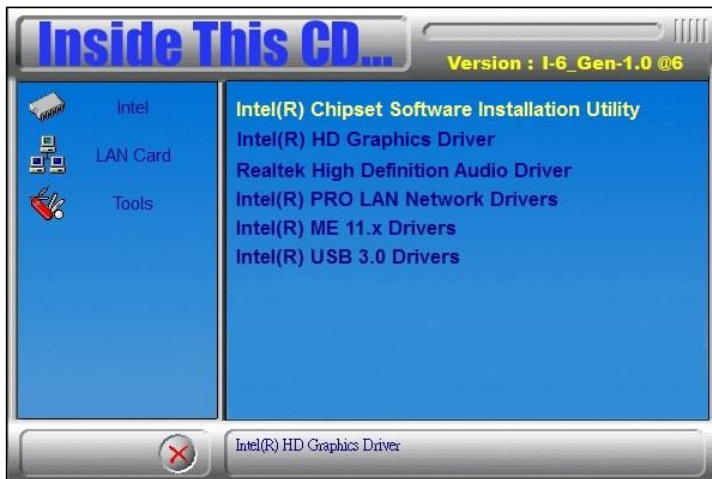

3. When the *Welcome* screen to the Intel® Chipset Device Software appears, click **Next** to continue.
4. Click **Yes** to accept the software license agreement and proceed with the installation process.
5. On the *Readme File Information* screen, click **Next** for installation.
6. The driver has been completely installed. You are suggested to restart the computer changes to take effect.

3.3 VGA Driver Installation

1. Click **Intel** and then **Intel(R) Skylake-U Chipset Drivers**.



2. Click **Intel(R) HD Graphics Driver**.



3. When the *Welcome* screen appears, click **Next** to continue.

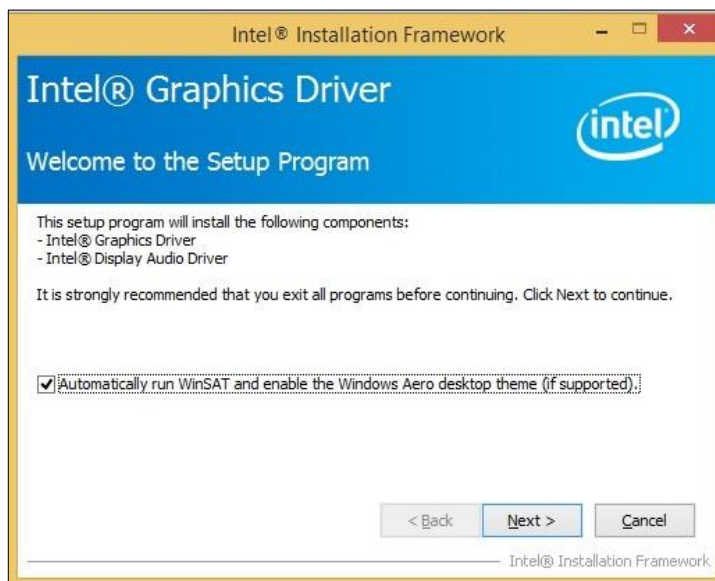

4. Click **Yes** to agree with the license agreement and then click **Install** for installation.
5. The driver has been completely installed. You are suggested to restart the computer for changes to take effect.

3.4 HD Audio Driver Installation

1. Click **Intel** and then **Intel(R) Skylake-U Chipset Drivers**.



2. Click **Realtek High Definition Audio Driver**.



3. On the *Welcome* screen of the InstallShield Wizard, click **Next** for installation.

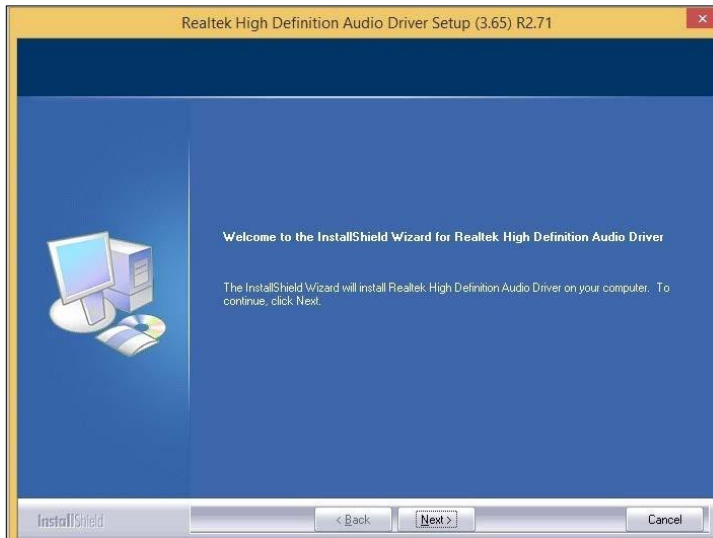

4. The driver has been completely installed. You are suggested to restart the computer for changes to take effect.

3.5 LAN Driver Installation

1. Click **LAN Card** and then **Intel(R) Skylake-U Chipset Drivers**



2. Click **Intel(R) PRO LAN Network Drivers..**



3. On the screen of Intel® Network Connections, click **Install Drivers and Software**.

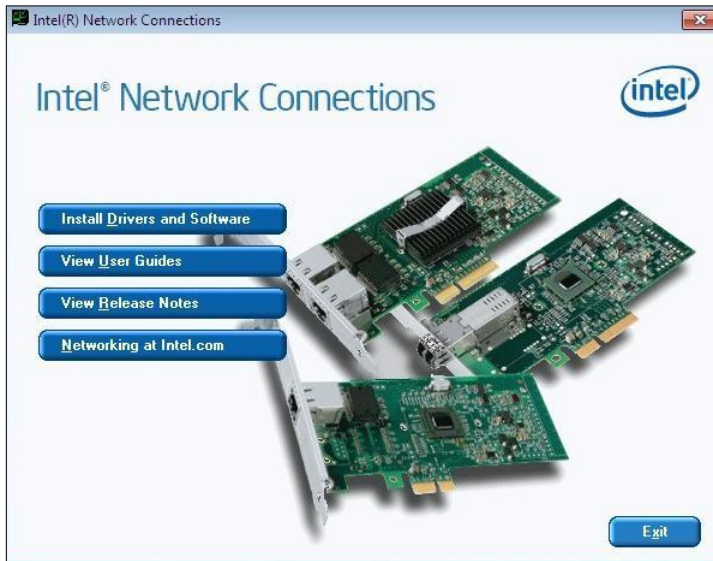

4. When the *Welcome* screen appears, click **Next** to continue.

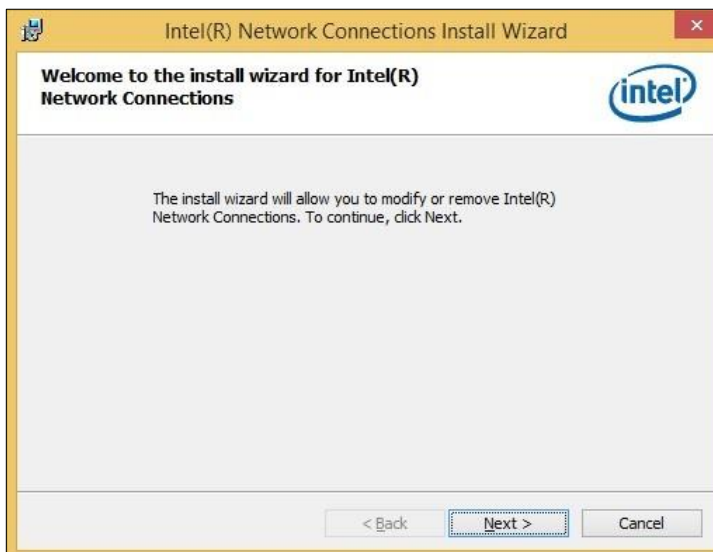

5. Accept the license agreement and click **Next** to continue.

6. Tick the checkbox for **Drivers** to select the related drivers and click **Next**.

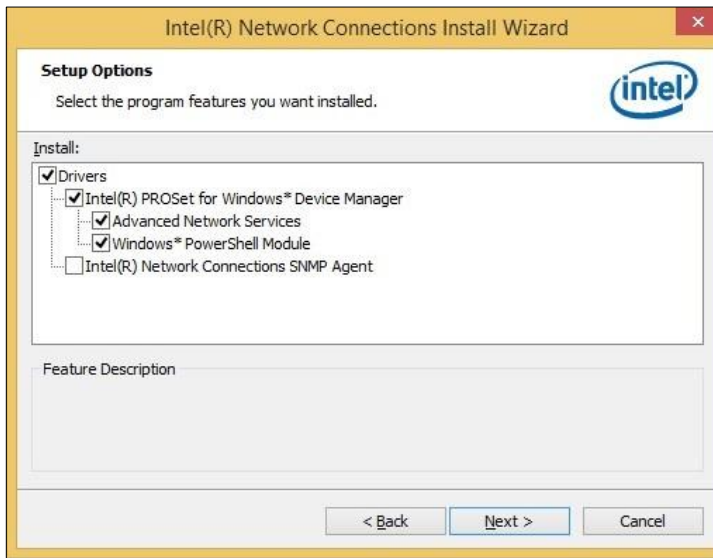

7. When the wizard is ready for installation, click **Install**.
8. The driver has been completely installed. You are suggested to restart the computer for changes to take effect.

3.6 Intel® Management Engine Driver Installation

1. Click **Intel** and then **Intel(R) Skylake-U Chipset Drivers**.



2. Click **Intel(R) ME 11.x Drivers**.



3. When the *Welcome* screen appears, click **Next** to continue.



4. Accept the licence agreement and click **Next** until the installation starts.
5. The driver has been completely installed. You are suggested to restart the computer for changes to take effect.

3.7 USB 3.0 Driver Installation

1. Click **Intel** and then **Intel(R) Skylake-U Chipset Drivers**.



2. Click **Intel(R) USB 3.0 Drivers**.



3. When the *Welcome* screen appears, click **Next** to continue.

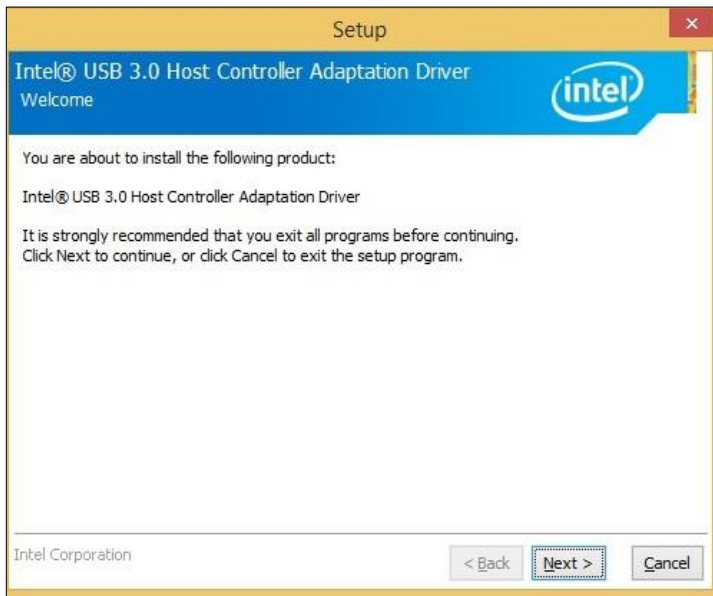

4. Accept the license agreement and click **Next** to continue.
5. On the *Readme File Information* screen, click **Next** for installation.
6. The driver has been completely installed. You are suggested to restart the computer for changes to take effect.

Chapter 4

BIOS Setup

This chapter describes the different settings available in the AMI BIOS that comes with the board. The topics covered in this chapter are as follows:

- Main Settings
- Advanced Settings
- Security Settings
- Boot Settings
- Save & Exit

4.1 Introduction

The BIOS (Basic Input/Output System) installed in the ROM of your computer system supports Intel® processors. The BIOS provides critical low-level support for standard devices such as disk drives, serial ports and parallel ports. It also provides password protection as well as special support for detailed fine-tuning of the chipset controlling the entire system.

4.2 BIOS Setup

The BIOS provides a Setup utility program for specifying the system configurations and settings. The BIOS ROM of the system stores the Setup utility. When you turn on the computer, the BIOS is immediately activated. Press the key immediately allows you to enter the Setup utility. If you are a little bit late pressing the key, POST (Power On Self Test) will continue with its test routines, thus preventing you from invoking the Setup.

If you still need to enter Setup, restart the system by pressing the "Reset" button or simultaneously pressing the <Ctrl>, <Alt> and <Delete> keys. You can also restart by turning the system Off and back On again.

The following message will appear on the screen:

```
Press <DEL> to Enter Setup
```

In general, press the arrow keys to highlight items, <Enter> to select, the <PgUp> and <PgDn> keys to change entries, <F1> for help, and <Esc> to quit.

When you enter the BIOS Setup utility, the *Main Menu* screen will appear on the screen. The Main Menu allows you to select from various setup functions and exit choices.

Warning: It is strongly recommended that you avoid making any changes to the chipset defaults.

These defaults have been carefully chosen by both AMI and your system manufacturer to provide the absolute maximum performance and reliability. Changing the defaults could make the system unstable and crash in some cases.

4.3 Main Settings

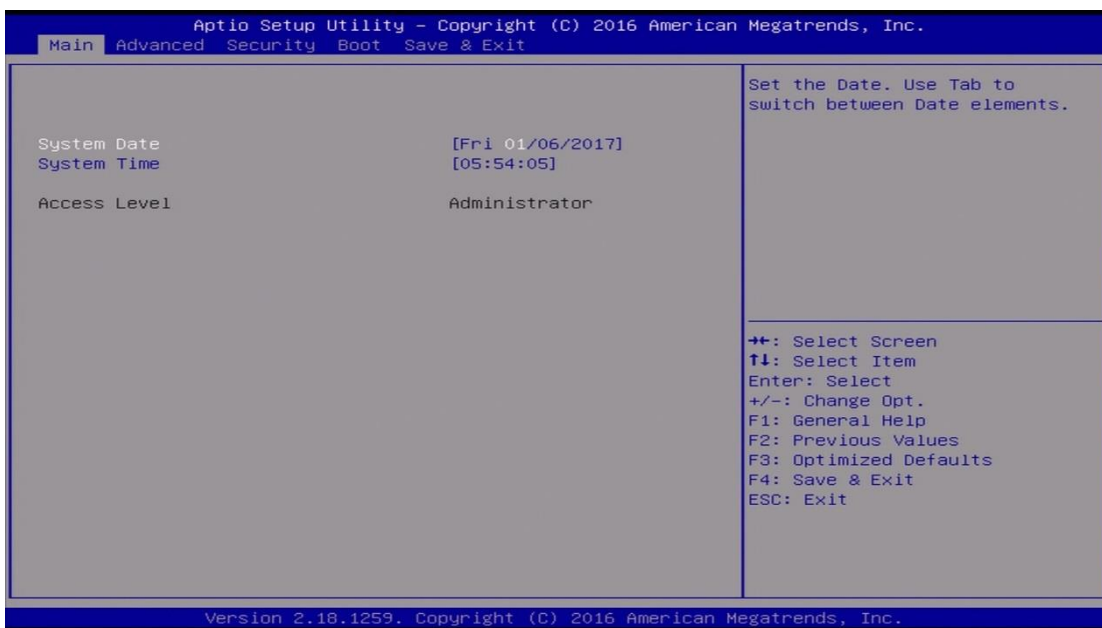

BIOS Setting	Description
System Date	Sets the date. Use the <Tab> key to switch between the date elements.
System Time	Set the time. Use the <Tab> key to switch between the time elements.

4.4 Advanced Settings

This section allows you to configure, improve your system and allows you to set up some system features according to your preference.

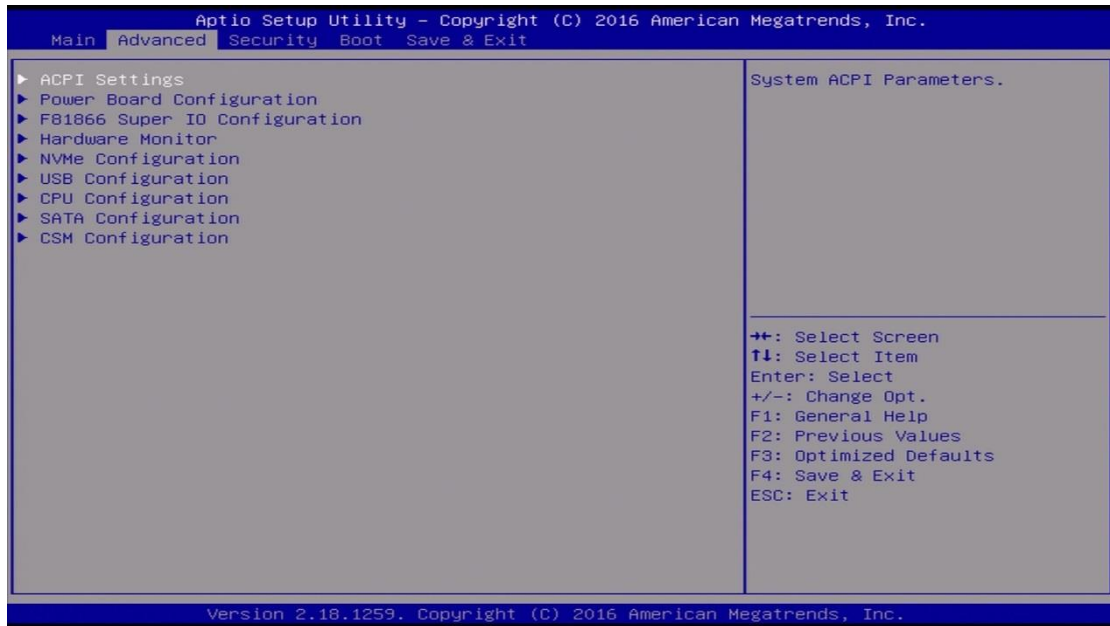

4.4.1 ACPI Settings

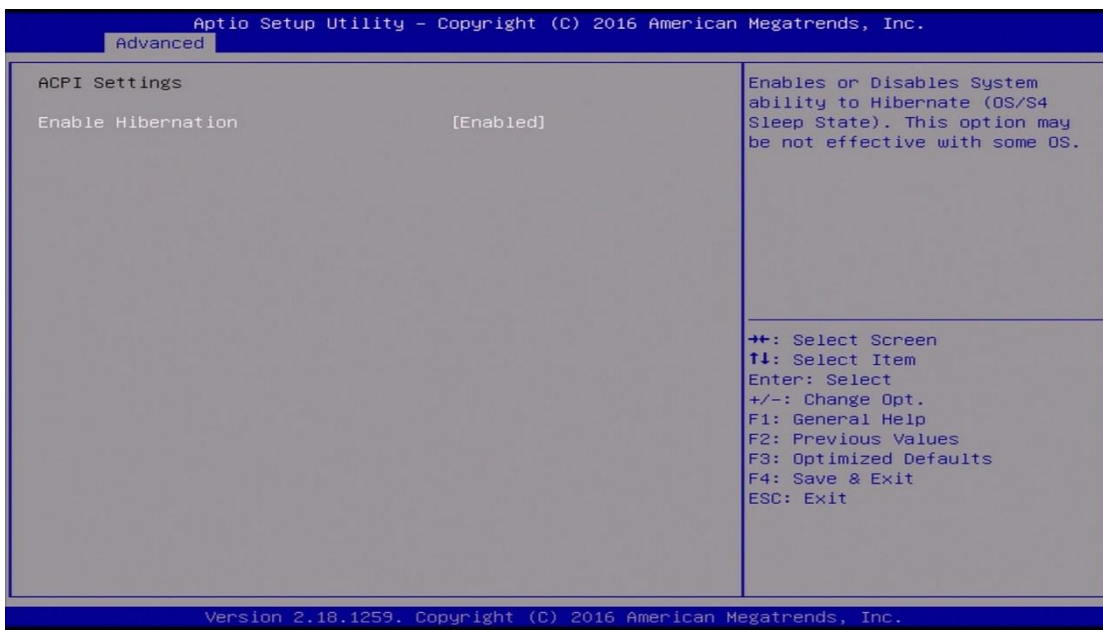

BIOS Setting	Description
Enable Hibernation	Enables or disables the System ability to Hibernate (OS/S4 Sleep State). This option may not be effective with some OS.

4.4.2 Power Board Configuration

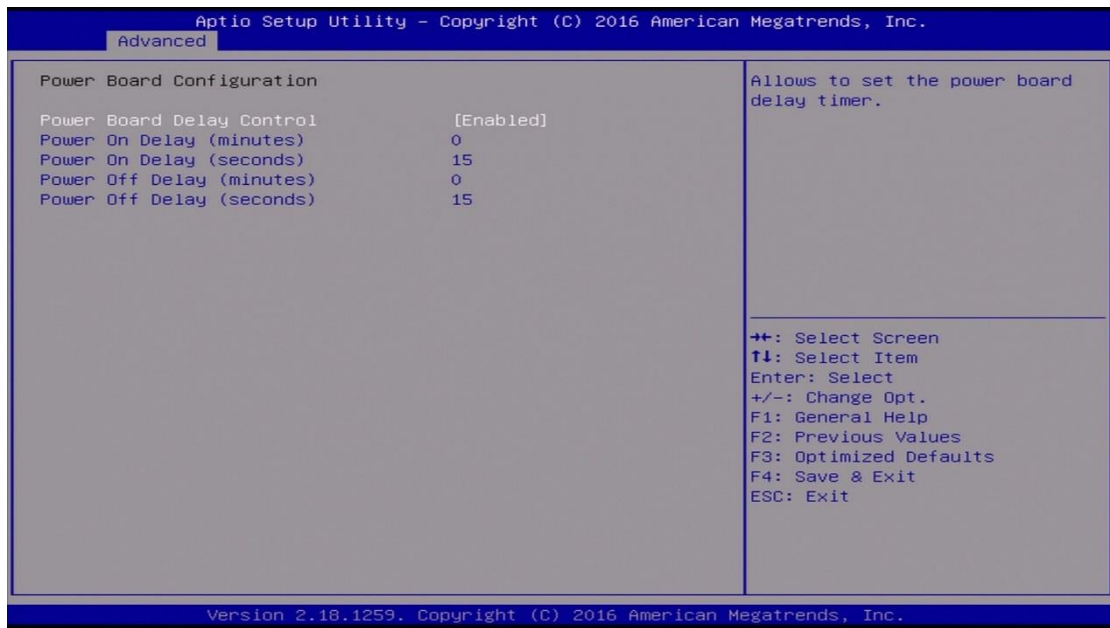

BIOS Setting	Description
Power Board Delay Control	Allows to set the delay timer for turning on or off the power board.
Power On Delay (minutes) / (seconds)	Sets the power-on-delay timer for minutes / seconds.
Power Off Delay (minutes) / (seconds)	Sets the power-off-delay timer for minutes / seconds.

4.4.3 Super IO Configuration

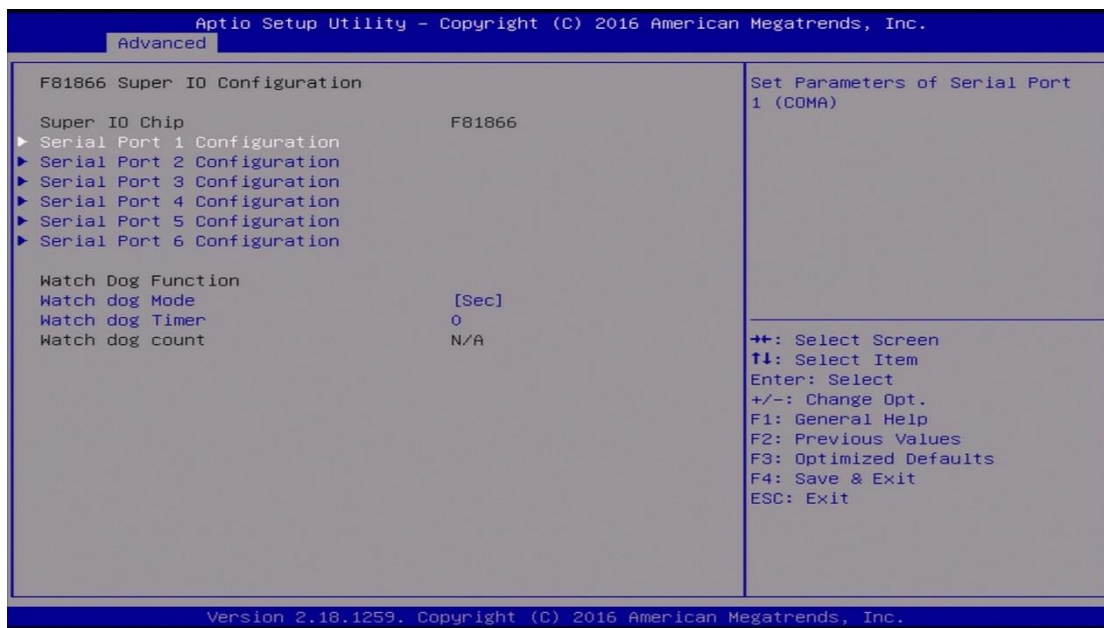

BIOS Setting	Description
Serial Port Configuration	<p>Sets parameters of serial ports.</p> <p>You can enable / disable the serial port and select an optimal settings for the Super IO device.</p> <p>* COM5 is for internal use only. COM6 sigals come from the on-board connector J11, and is reserved for future use to connect to CAN module.</p>
Watchdog Mode	Sets the Watchdog mode as Second or Miniute.
Watchdog Timer	Sets the Watchdog timer. 00 disables the timer.

4.4.3.1. Serial Port 1 Configuration

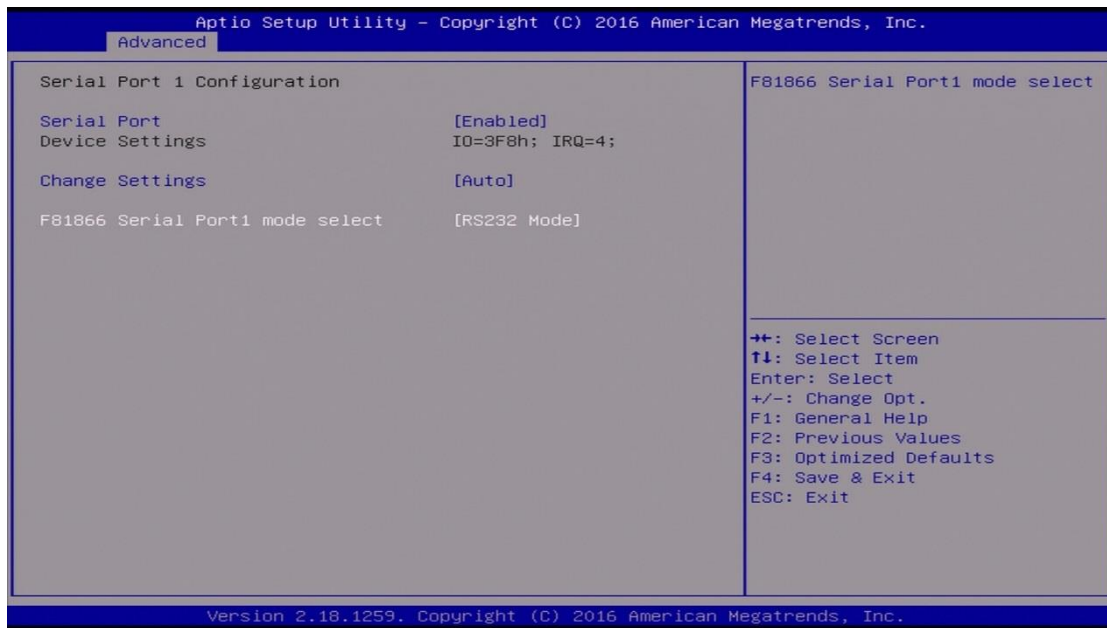

BIOS Setting	Description
Serial Port	Enables / Disables the serial port (COM).
Change Settings	Selects an optimal settings for the Super I/O device.
F81866 Serial Port1 Mode Seelct	Changes the mode of serial port.

4.4.3.2. Serial Port 2 Configuration

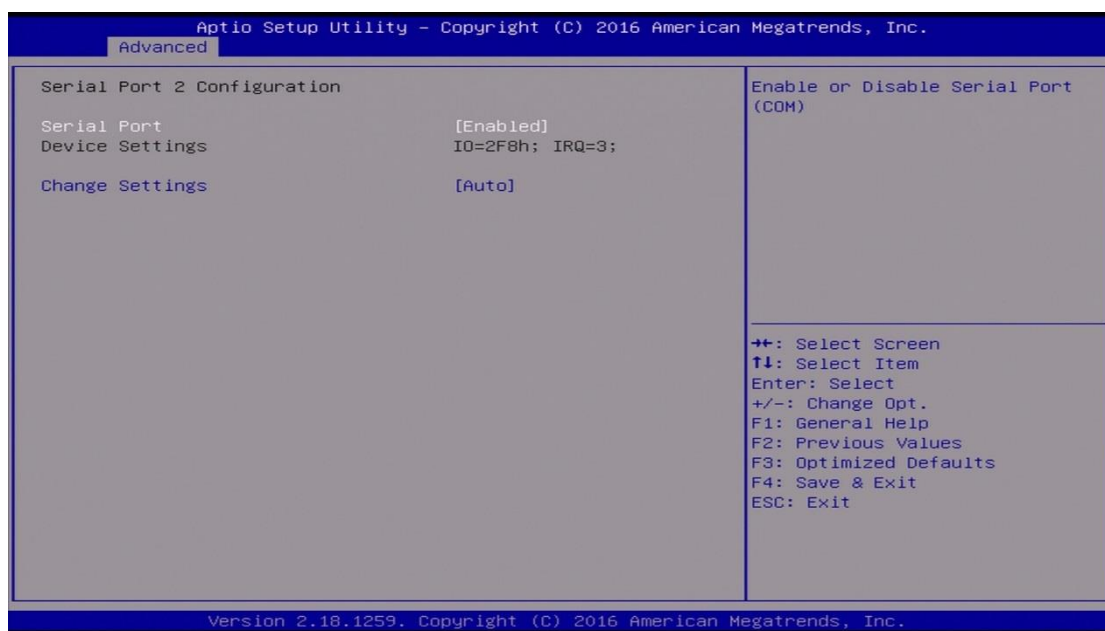

BIOS Setting	Description
Serial Port	Enables / Disables the serial port (COM).
Change Settings	Selects an optimal settings for the Super I/O device.

4.4.3.3. Serial Port 3 Configuration

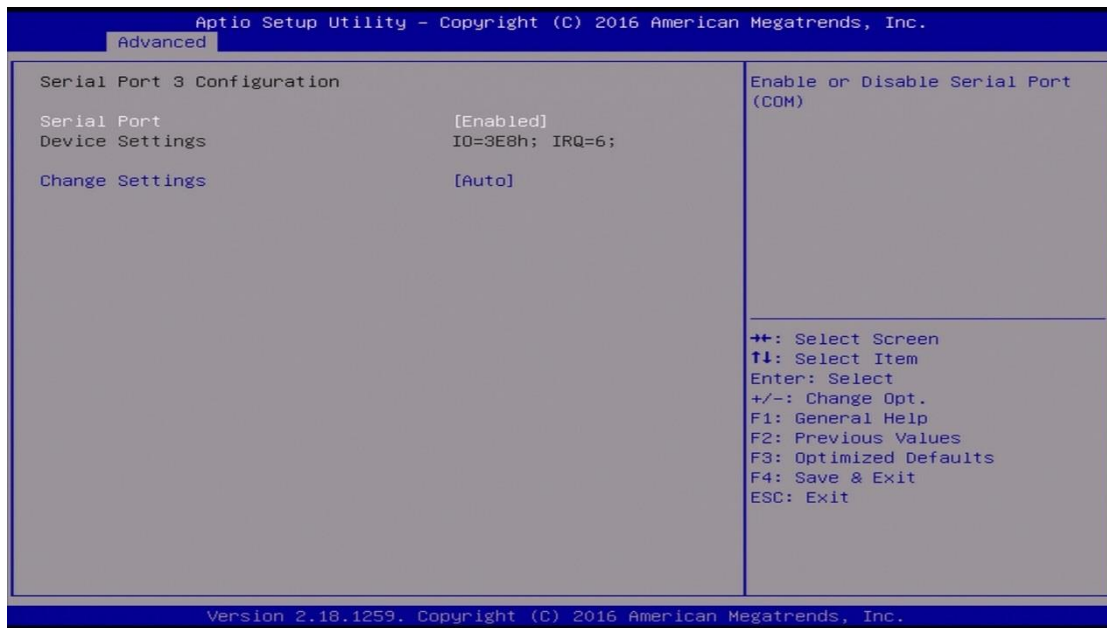

BIOS Setting	Description
Serial Port	Enables / Disables the serial port (COM).
Change Settings	Selects an optimal settings for the Super I/O device.

4.4.3.4. Serial Port 4 Configuration

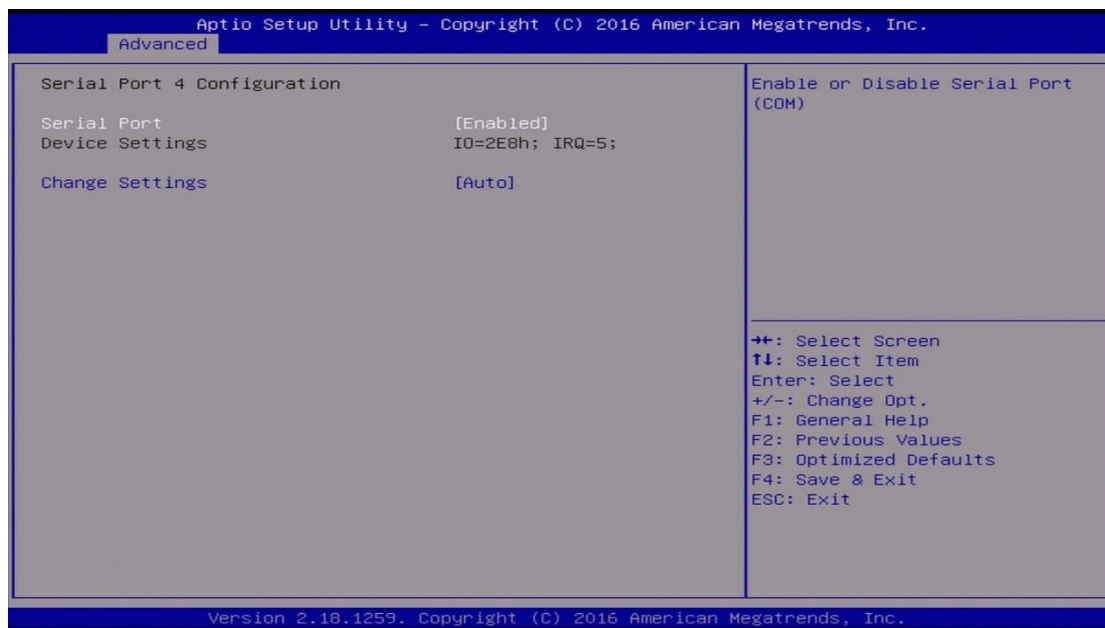

BIOS Setting	Description
Serial Port	Enables / Disables the serial port (COM).
Change Settings	Selects an optimal settings for the Super I/O device.

4.4.3.5. Serial Port 5 Configuration

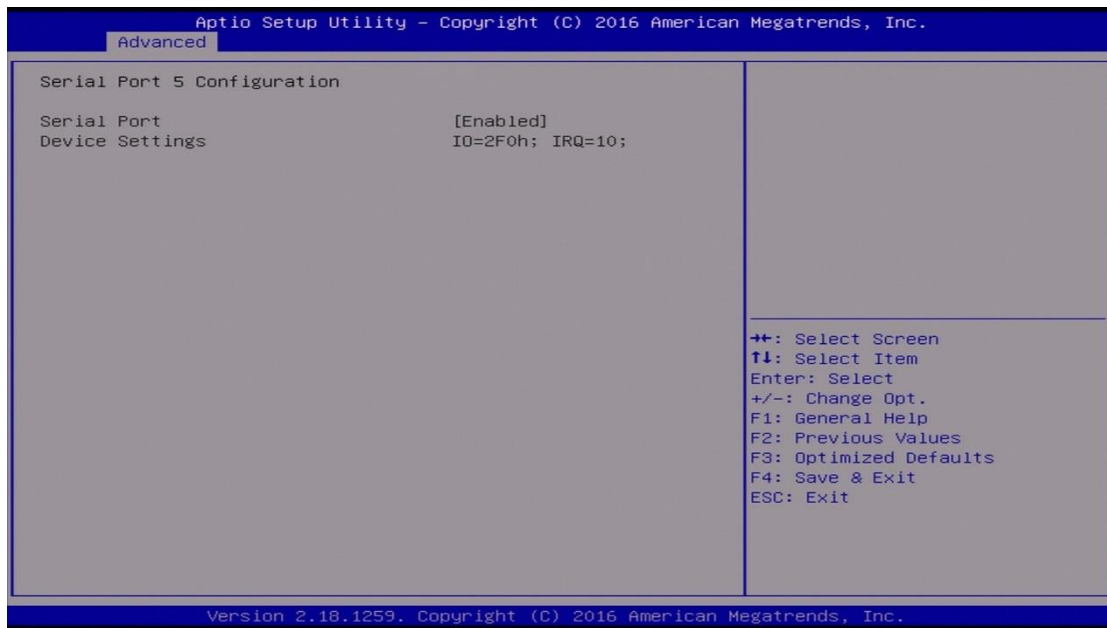

4.4.3.6. Serial Port 6 Configuration

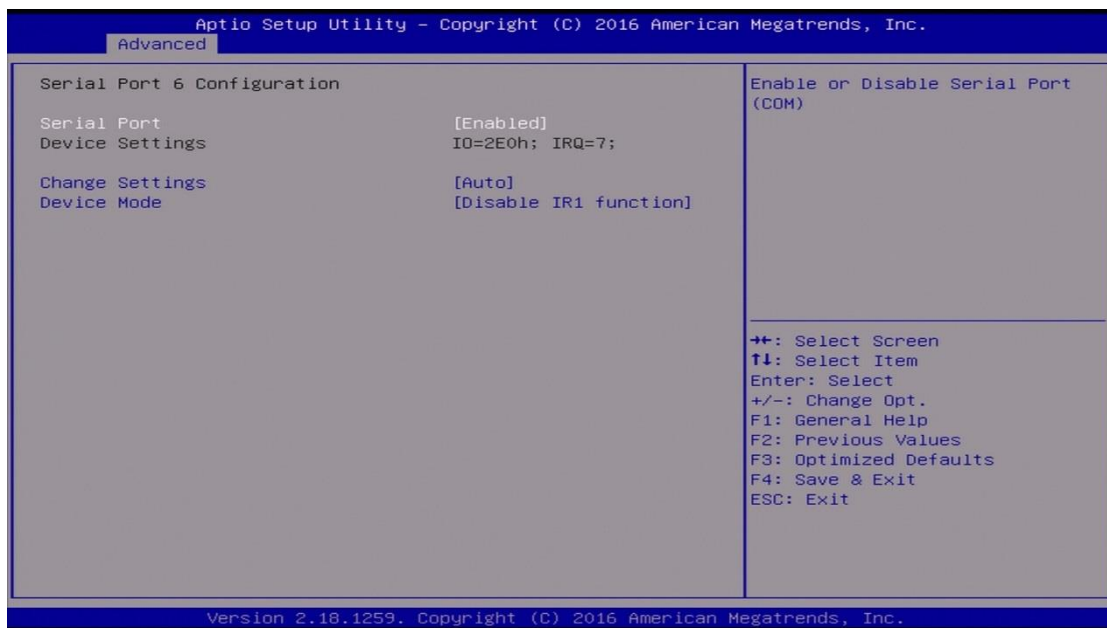

BIOS Setting	Description
Serial Port	Enables / Disables the serial port (COM).
Change Settings	Selects an optimal settings for the Super I/O device.
Device Mode	Changes the mode of serial port.

4.4.4 Hardware Monitor

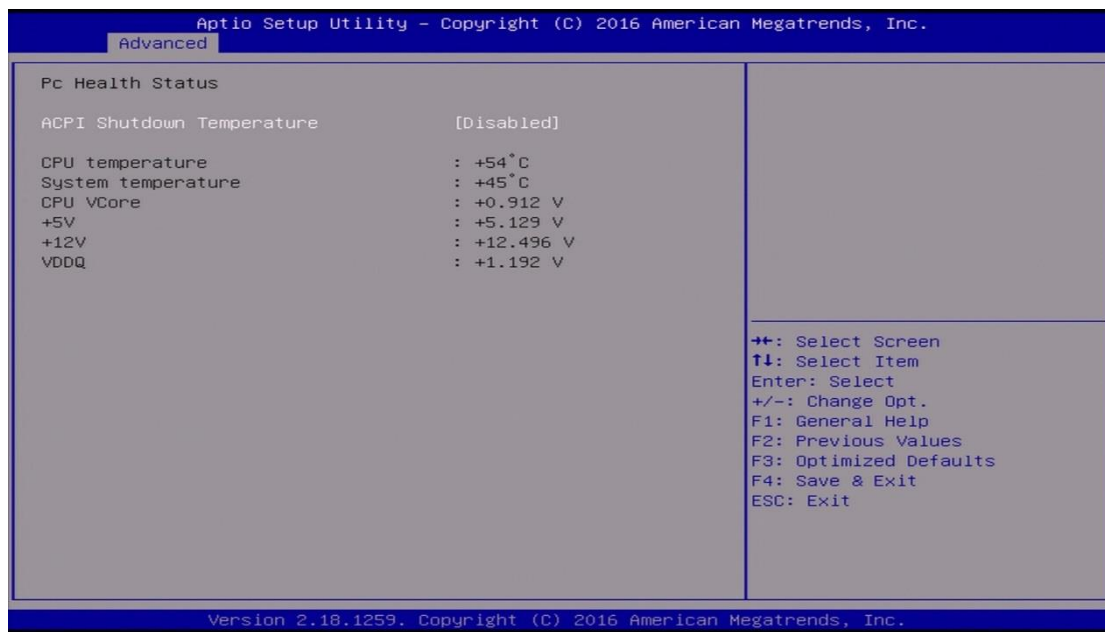

BIOS Setting	Description
ACPI Shutdown Temperature	This field enables or disables the Shutdown Temperature Options: Disabled (default). 70 °C, 80 °C, 90 °C
Temperatures / Voltages	These fields are the parameters of the hardware monitoring function feature of the motherboard. The values are read-only values as monitored by the system and show the PC health status

4.4.5 NVMe Configuration

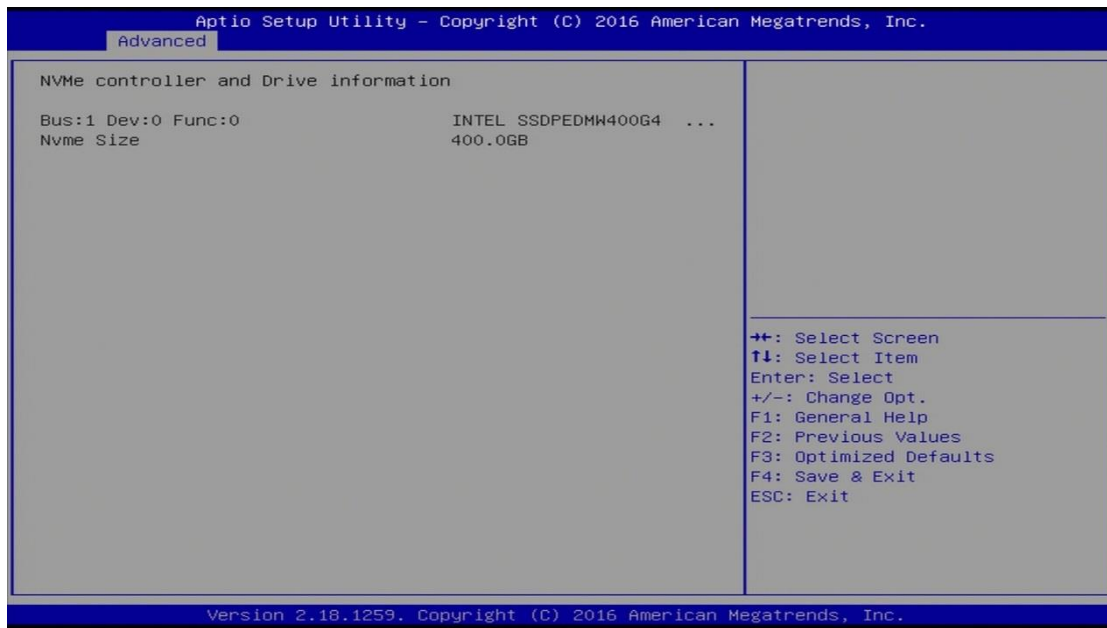

4.4.6 USB Configuration

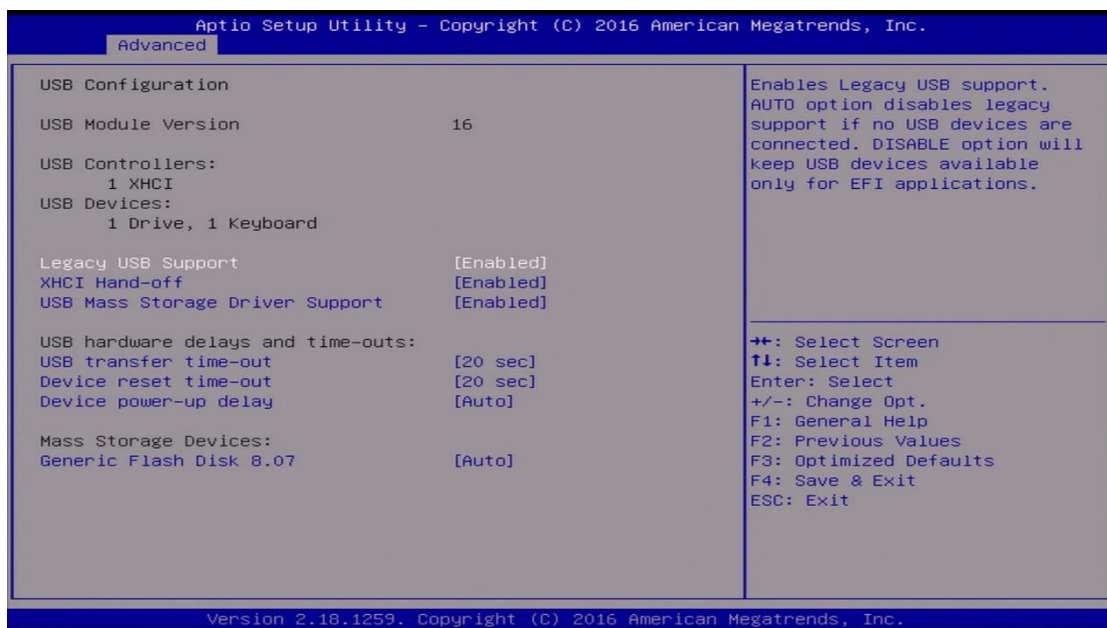

BIOS Setting	Description
Legacy USB Support	<p>Enables / Disables Legacy USB support.</p> <ul style="list-style-type: none"> • Auto disables legacy support if there is no USB device connected. • Disable keeps USB devices available only for EFI applications.

BIOS Setting	Description
XHCI Hand-pff	This is a workaround for OSES without XHCI hand-off support. The XHCI ownership change should be claimed by XHCI driver.
USB Mass Storage Driver Support	Enables / Disables USB mass storage driver support.
USB Transfer time-out	Sets the time-out value 1, 5, 10 or 20 sec(s) for Control, Bulk, and Interrupt transfers.
Device reset time-out	Sets the seconds (10, 20, 30, 40 secs) of delaying execution of start unit command to USB mass storage device.
Device power-up delay	The maximum time the device will take before it properly reports itself to the Host Controller. Auto uses default value. For a Root port, it is 100 ms. For a Hub port, the delay is taken from Hub descriptor.
Generic Flash Disk 8.07	Mass storage device emulation type. Auto enumerates devices according to their media format. Optical drives are emulated as "CD-ROM", drives with no media will be emulated according to a drive type.

4.4.7 CPU Configuration

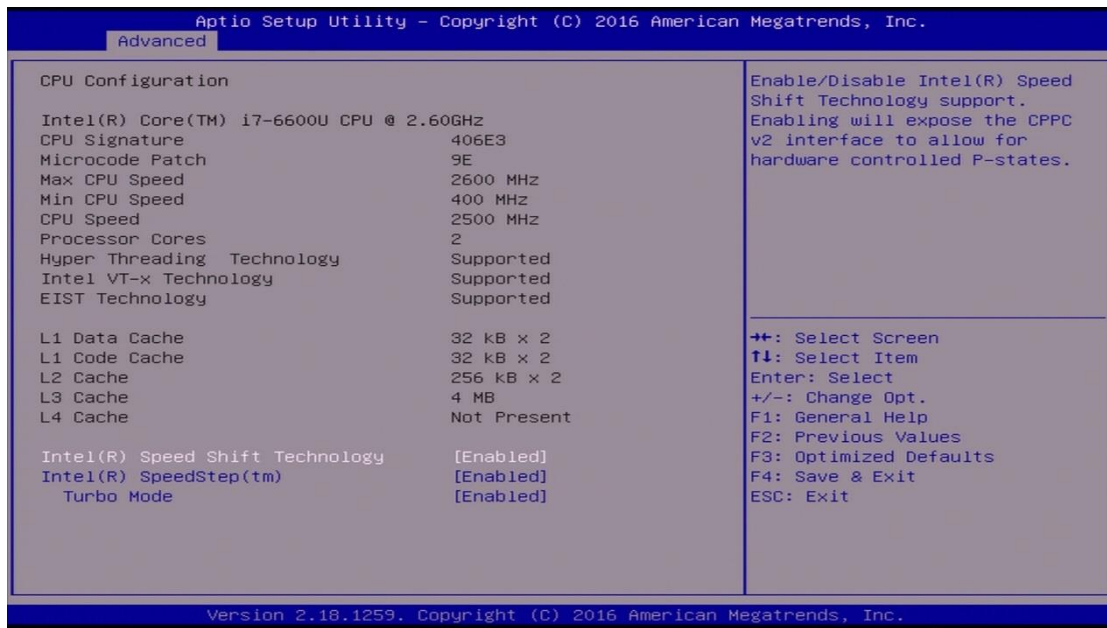

BIOS Setting	Description
Intel(R) Speed Shift Technology	Enables / Disables the support for Intel(R) Speed Shift Technology. If enabled, it will expose the CPPC v2 interface to allow for hardware controlled P states.
Intel(R) SpeedStep(tm)	Enables / Disables to support more than two frequency ranges.
Turbo Mode	Enables / Disables the turbo mode.

4.4.8 SATA Configuration

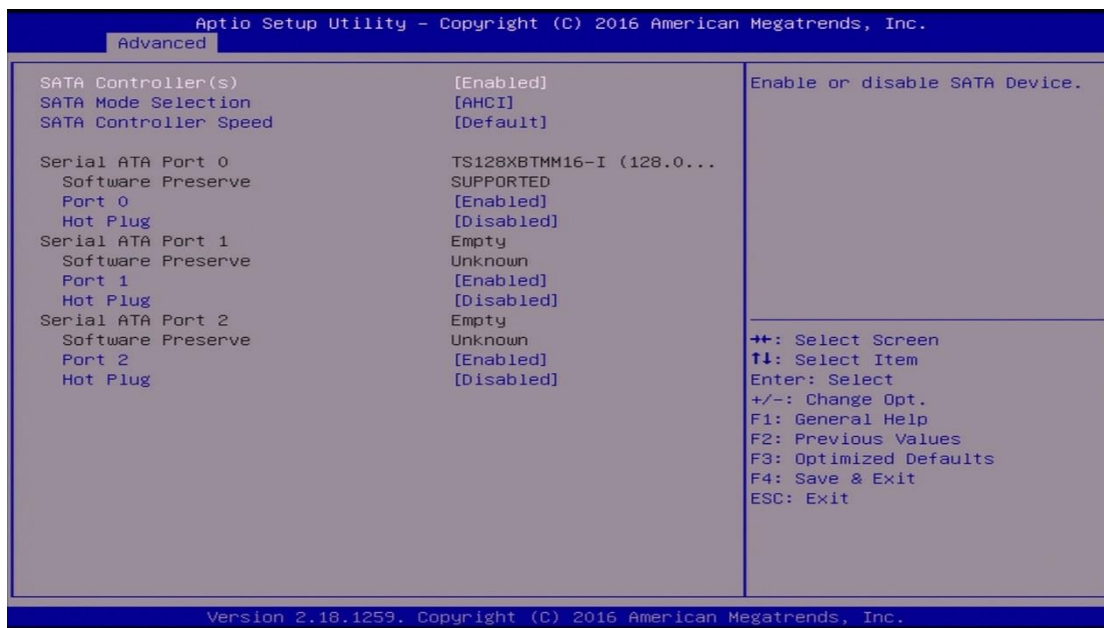

BIOS Setting	Description
SATA Controller(s)	Enables / Disables SATA devices.
SATA Mode Selection	Selects AHCI / RAID Mode.
SATA Controller Speed	Indicates the maximum speed that the SATA controller supports.
Serial ATA Port 0/1/2	Enables / Disables Serial Port 0/1/2.
HotPlug	Designates the SATA port as hot pluggable.

4.4.9 CSM Configuration

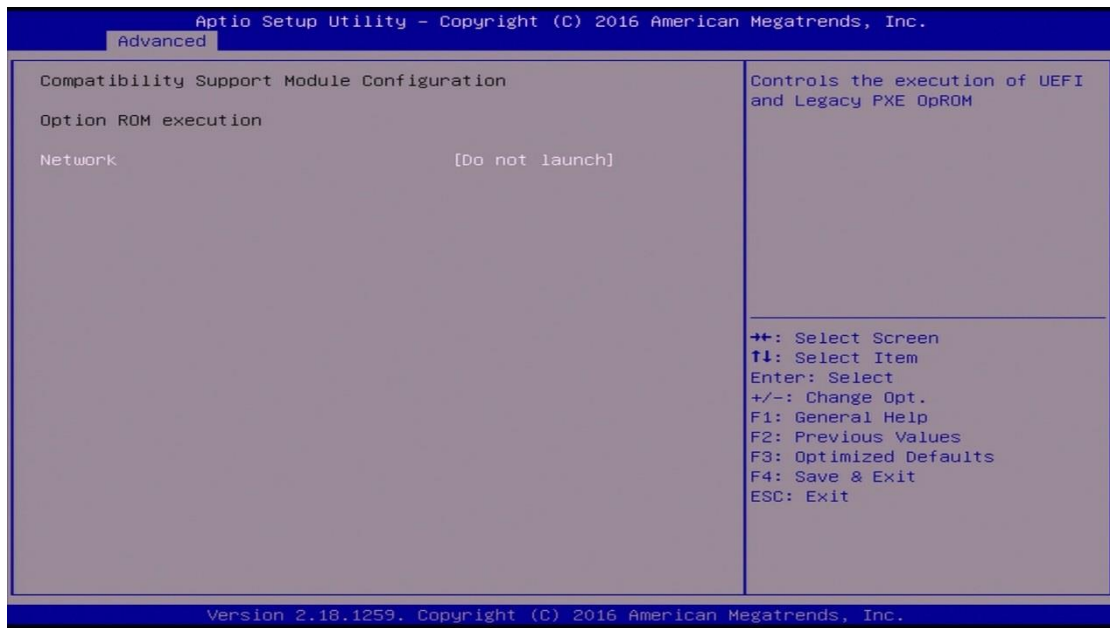

BIOS Setting	Description
Network	Controls the execution of UEFI and Legacy PXE OpROM.

4.5 Security Settings

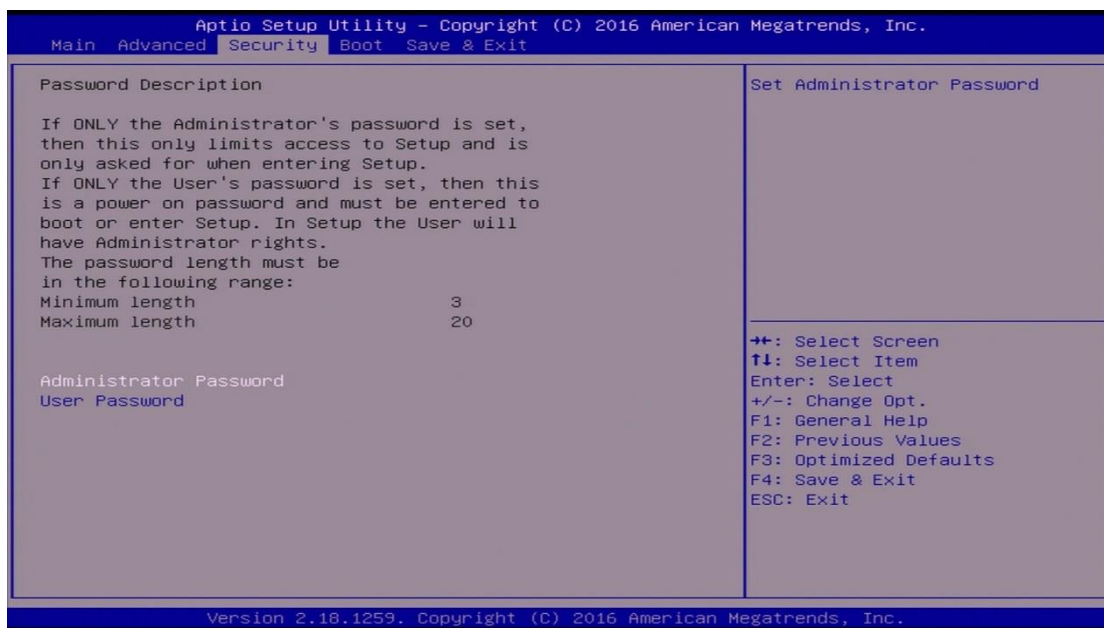

BIOS Setting	Description
Administrator Password	Sets an administrator password for the setup utility.
User Password	Sets a user password.

4.6 Boot Settings

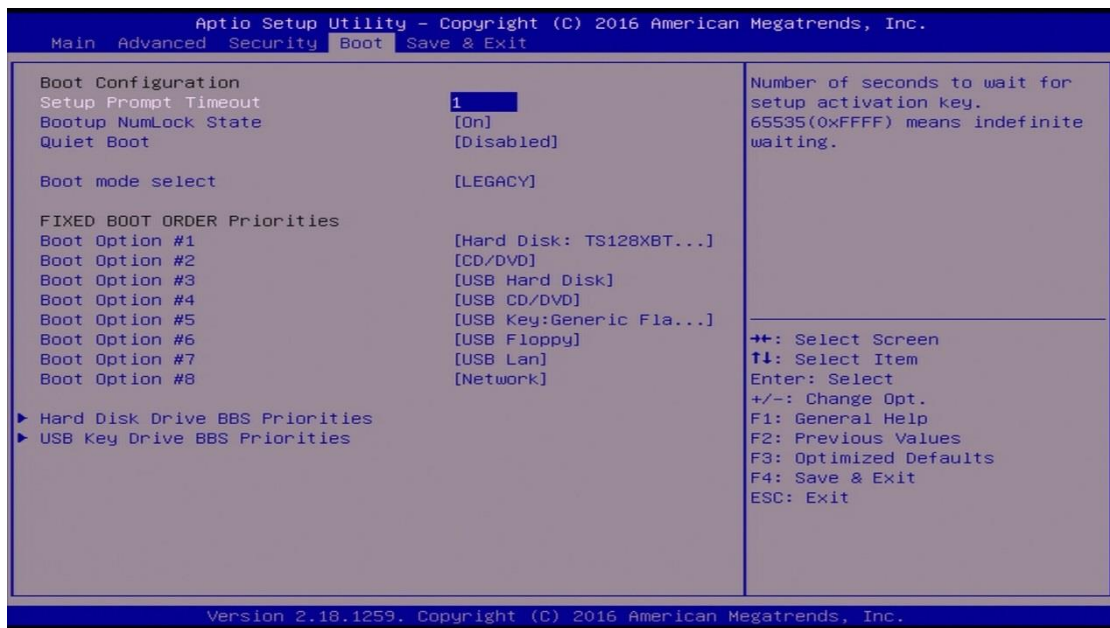

BIOS Setting	Description
Setup Prompt Timeout	Number of seconds to wait for setup activation key. 65535 (0xFFFF) means indefinite waiting.
Bootup NumLock State	Selects the keyboard NumLock state.
Quiet Boot	Enables / Disables Quiet Boot option.
Boot Mode Select	Selects the boot mode as Legacy or UEFI.
Boot Option Priorities	Sets the system boot order.
Hard Disk Drive BBS Priorities	Specifies the boot device priority sequence from available Hard Disk Drives.
USB Key Drive BBS Priorities	Specifies the boot device priority sequence from available USB key drives.

4.7 Save & Exit Settings

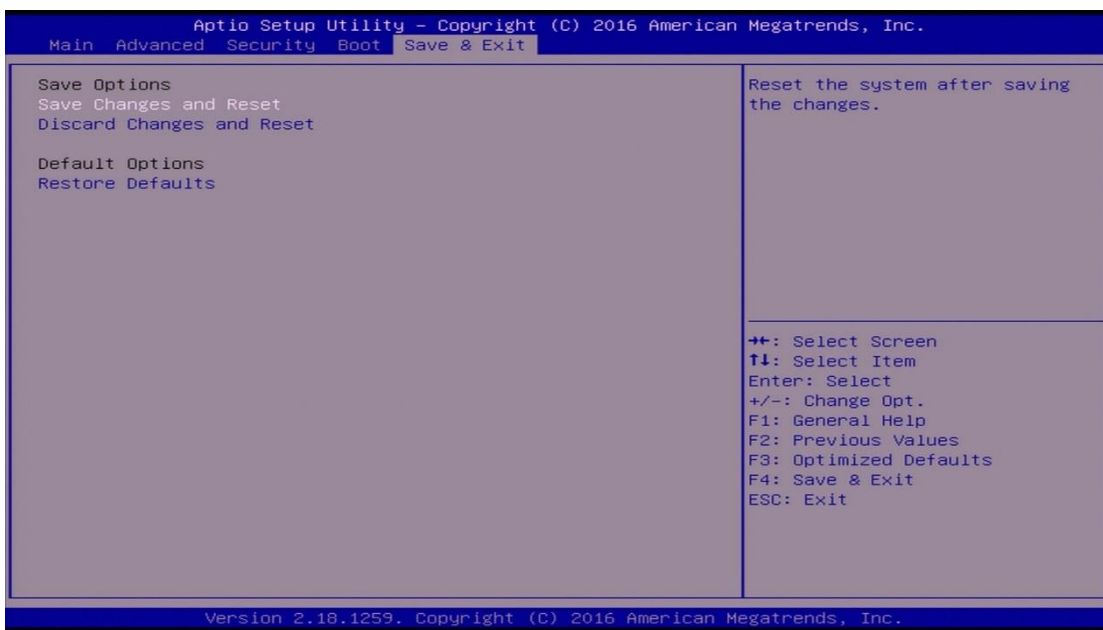

BIOS Setting	Description
Save Changes and Reset	Resets the system after saving the changes.
Discard Changes and Reset	Resets system setup without saving any changes.
Restore Defaults	Restores the user defaults to all the setup options.

Appendix

This section provides the mapping addresses of peripheral devices and the sample code of watchdog timer configuration.

- I/O Port Address Map
- Interrupt Request Lines (IRQ)
- Watchdog Timer Configuration
- Software Development Kit for WDT.DLL

A. I/O Port Address Map

Each peripheral device in the system is assigned a set of I/O port addresses which also becomes the identity of the device. The following table lists the I/O port addresses used.

Address	Device Description
070h – 077h	Real Time Clock
2E0h – 2E7h	Serial Port #6(COM6) * COM6 sigals come from the on-board connector J11, and is reserved for future use to connect to CAN module.
2E8h – 2EFh	Serial Port #4(COM4)
2F0h – 2F7h	Serial Port #3(COM5) * COM5 is for internal use only.
2F8h – 2FFh	Serial Port #2(COM2)
3B0h – 3DFh	Intel(R) HD Graphics
3E8h – 3EFh	Serial Port #5(COM3)
3F8h – 3FFh	Serial Port #1(COM1)
0D00 – FFFF	PCI-e Root Complex

B. Interrupt Request Lines (IRQ)

Peripheral devices use interrupt request lines to notify CPU for the service required. The following table shows the IRQ used by the devices on board.

Level	Function
IRQ0	System Timer
IRQ3	Serial Port #2
IRQ4	Serial Port #1
IRQ5	Serial Port #4
IRQ6	Serial Port #3
IRQ7	Serial Port #6
IRQ8	System CMOS/real time clock
IRQ10	Serial Port #5
IRQ18	High Definition Audio Controller

C. Watchdog Timer Configuration

The Watchdog Timer (WDT) is used to generate a variety of output signals after a user programmable count. The WDT is suitable for the use in the prevention of system lock-up, such as when software becomes trapped in a deadlock. Under these sorts of circumstances, the timer will count to zero and the selected outputs will be driven.

Under normal circumstance, you will need to restart the WDT at regular intervals before the timer counts to zero.

Sample Code:

```
//-----  
//  
// THIS CODE AND INFORMATION IS PROVIDED "AS IS" WITHOUT WARRANTY OF ANY  
// KIND, EITHER EXPRESSED OR IMPLIED, INCLUDING BUT NOT LIMITED TO THE  
// IMPLIED WARRANTIES OF MERCHANTABILITY AND/OR FITNESS FOR A PARTICULAR  
// PURPOSE.  
//  
//-----  
#include <dos.h>  
#include <conio.h>  
#include <stdio.h>  
#include <stdlib.h>  
#include "F81866.H"  
//-----  
int main (int argc, char *argv[]); void EnableWDT(int);  
void DisableWDT(void);  
//-----  
int main (int argc, char *argv[])  
{  
    unsigned char bBuf; unsigned char bTime; char **endptr;  
  
    char SIO;  
    printf("Fintek 81866 watch dog program\n"); SIO = Init_F81866();  
    if (SIO == 0)  
    {  
        printf("Can not detect Fintek 81866, program abort.\n"); return(1);  
    }/if (SIO == 0)  
  
    if (argc != 2)  
    {  
        printf(" Parameter incorrect!!\n"); return (1);  
    }  
  
    bTime = strtol (argv[1], endptr, 10);  
    printf("System will reset after %d seconds\n", bTime);  
  
    if (bTime)  
    {    EnableWDT(bTime); } else  
    {    DisableWDT(); } return 0;
```

```

}
//-----
void EnableWDT(int interval)
{
unsigned char bBuf;

bBuf = Get_F81866_Reg(0x2B); bBuf &= (~0x20);
Set_F81866_Reg(0x2B, bBuf); //Enable WDTO

Set_F81866_LD(0x07); //switch to logic device 7
Set_F81866_Reg(0x30, 0x01); //enable timer

bBuf = Get_F81866_Reg(0xF5); bBuf &= (~0x0F);
bBuf |= 0x52;
Set_F81866_Reg(0xF5, bBuf); //count mode is second Set_F81866_Reg(0xF6,
interval); //set timer
bBuf = Get_F81866_Reg(0xFA); bBuf |= 0x01;
Set_F81866_Reg(0xFA, bBuf); //enable WDTO output

bBuf = Get_F81866_Reg(0xF5); bBuf |= 0x20;
Set_F81866_Reg(0xF5, bBuf); //start counting
}
//-----
void DisableWDT(void)
{
unsigned char bBuf;
Set_F81866_LD(0x07); //switch to logic device 7 bBuf = Get_F81866_Reg(0xFA);
bBuf &= ~0x01;
Set_F81866_Reg(0xFA, bBuf); //disable WDTO output

bBuf = Get_F81866_Reg(0xF5); bBuf &= ~0x20;
bBuf |= 0x40;
Set_F81866_Reg(0xF5, bBuf); //disable WDT
}
//-----

```

```
//-----  
//  
// THIS CODE AND INFORMATION IS PROVIDED "AS IS" WITHOUT WARRANTY OF ANY  
// KIND, EITHER EXPRESSED OR IMPLIED, INCLUDING BUT NOT LIMITED TO THE  
// IMPLIED WARRANTIES OF MERCHANTABILITY AND/OR FITNESS FOR A PARTICULAR  
// PURPOSE.  
//  
//-----  
#include "F81866.H"  
#include <dos.h>  
//-----  
unsigned int F81866_BASE; void Unlock_F81866 (void); void Lock_F81866 (void);  
//-----  
unsigned int Init_F81866(void)  
{  
    unsigned int result; unsigned char ucDid;  
  
    F81866_BASE = 0x4E;  
    result = F81866_BASE;  
  
    ucDid = Get_F81866_Reg(0x20);  
    if (ucDid == 0x07) //Fintek 81866  
    {    goto Init_Finish; }  
  
    F81866_BASE = 0x2E;  
    result = F81866_BASE;  
  
    ucDid = Get_F81866_Reg(0x20);  
    if (ucDid == 0x07) //Fintek 81866  
    {    goto Init_Finish; }  
  
    F81866_BASE = 0x00;  
    result = F81866_BASE;  
  
    Init_Finish:  
    return (result);  
}  
//-----  
void Unlock_F81866 (void)  
{  
    outportb(F81866_INDEX_PORT, F81866_UNLOCK); outportb(F81866_INDEX_PORT,  
    F81866_UNLOCK);  
}  
//-----  
void Lock_F81866 (void)  
{  
    outportb(F81866_INDEX_PORT, F81866_LOCK);  
}  
//-----  
void Set_F81866_LD( unsigned char LD)  
{  
    Unlock_F81866();  
    outportb(F81866_INDEX_PORT, F81866_REG_LD);  
    outportb(F81866_DATA_PORT, LD); Lock_F81866();  
}
```

```

}
//-----
void Set_F81866_Reg( unsigned char REG, unsigned char DATA)
{
Unlock_F81866(); outportb(F81866_INDEX_PORT, REG); outportb(F81866_DATA_PORT,
DATA); Lock_F81866();
}
//-----
unsigned char Get_F81866_Reg(unsigned char REG)
{
unsigned char Result; Unlock_F81866();
outportb(F81866_INDEX_PORT, REG); Result = inportb(F81866_DATA_PORT);
Lock_F81866();
return Result;
}
//-----

//-----
//
// THIS CODE AND INFORMATION IS PROVIDED "AS IS" WITHOUT WARRANTY OF ANY
// KIND, EITHER EXPRESSED OR IMPLIED, INCLUDING BUT NOT LIMITED TO THE
// IMPLIED WARRANTIES OF MERCHANTABILITY AND/OR FITNESS FOR A PARTICULAR
// PURPOSE.
//
//-----
#ifndef F81866_H
#define F81866_H 1
//-----
#define F81866_INDEX_PORT (F81866_BASE)
#define F81866_DATA_PORT (F81866_BASE+1)
//-----
#define F81866_REG_LD 0x07
//-----
#define F81866_UNLOCK 0x87
#define F81866_LOCK 0xAA
//-----
unsigned int Init_F81866(void);
void Set_F81866_LD( unsigned char);
void Set_F81866_Reg( unsigned char, unsigned char); unsigned char
Get_F81866_Reg( unsigned char);
//-----
#endif // F81866_H

```

D. Software Development Kit for WDT.DLL

1. OS Supported

Windows XP (32-bit / 64-bit) or above

2. Driver Installation

- **For 32-bit environment:**

Step 1:

Copy the file **KMUI32_1K.SYS** to <%WINDIR%>\SYSTEM32\DRIVERS.

Step 2:

The following parameters must be written to your registry.

```
HKLM,"System\CurrentControlSet\Services\KMUI32_1K","ErrorControl",%REG_DWORD%,0x00000001
```

```
HKLM,"System\CurrentControlSet\Services\KMUI32_1K","Type",%REG_DWORD%,0x00000001
```

```
HKLM,"System\CurrentControlSet\Services\KMUI32_1K","Start",%REG_DWORD%,0x00000000
```

```
HKLM,"System\CurrentControlSet\Services\KMUI32_1K","DisplayName",%REG_SZ%,"KMUI32_1K"
```

Step 3:

Restart the system.

- **For 64-bit environment:**

Step 1:

Copy "KMUI64_1K.SYS" file to <%WINDIR%>\SYSTEM32\DRIVERS

Step 2:

The following parameters must be written to your registry.

```
HKLM,"System\CurrentControlSet\Services\KMUI64_1K","ErrorControl",%REG_DWORD%,0x00000001
```

```
HKLM,"System\CurrentControlSet\Services\KMUI64_1K","Type",%REG_DWORD%,0x00000001
```

```
HKLM,"System\CurrentControlSet\Services\KMUI64_1K","Start",%REG_DWORD%,0x00000000
```

```
HKLM,"System\CurrentControlSet\Services\KMUI64_1K","DisplayName",%REG_SZ%,"KMUI64_1K"
```

Step 3:

Restart the system.

Note: Do not install both of the 32-bit and 64-bit drivers on an operating system.

3. Exportion from IB_WDT.DLL / IB_WDT.64.DLL

```
extern "C" __declspec(dllexport) int __stdcall InstallDriver(void);
extern "C" __declspec(dllexport) int __stdcall RemoveDriver(void);
extern "C" __declspec(dllexport) char* __stdcall GetWDTInfo(void);
extern "C" __declspec(dllexport) int __stdcall EnableWDT(int);
extern "C" __declspec(dllexport) int __stdcall DisableWDT(int);
extern "C" __declspec(dllexport) int __stdcall IsDioAvailable(int);
extern "C" __declspec(dllexport) int __stdcall SetDioInputMask(int);
extern "C" __declspec(dllexport) int __stdcall SetDioOutputMask(int);
extern "C" __declspec(dllexport) int __stdcall GetDioInput(int);
extern "C" __declspec(dllexport) int __stdcall SetDioOutput(int);
```

Note:

1. The **IB_WDT.DLL** is of 32-bit and works on 32-bit and 64-bit Windows operating system. The "IB_WDT.64.DLL" is for 64bit Windows only.
 2. The routines are not thread-safe. Your software engineers should take the responsibility to avoid multi-entry condition.
-

● Driver Initialization & Deinitialization

```
extern "C" __declspec(dllexport) int __stdcall InstallDriver(void);
```

Input : None

Output : Return 1 if device driver loads successfully; otherwise return 0.

Note: This function should be invoked before Watchdog and Digital I/O routines.

```
extern "C" __declspec(dllexport) int __stdcall RemoveDriver(void);
```

Input : None

Output : Always return 1.

Note: This function should be invoked before the program closes and it will release the device driver and memory for **ib_wdt.dll**. If the program is closed without calling this routine, resource leak may occur.

- **Watchdog**

```
extern "C" __declspec(dllexport) char * __stdcall GetWDTInfo(void);
```

Input : None

Output : Return a string that describes the module information.

```
extern "C" __declspec(dllexport) int __stdcall EnableWDT(int);
```

Input : Timer interval, depending on the WDT chip

Output : Always return "0"

For further information, refer to the datasheet for WDT or contact your sales representative.

```
extern "C" __declspec(dllexport) int __stdcall DisableWDT(int);
```

Input : Dummy data and will be ignored.

Output : Always return "0"

- **Digital I/O**

```
extern "C" __declspec(dllexport) int __stdcall IsDioAvailable(int);
```

Input : Dummy data and will be ignored

Output : Return 1 if the digital I/O is available, otherwise return 0.

```
extern "C" __declspec(dllexport) int __stdcall SetDioInputMask(int);
```

Input: : Hardware parameter for digital I/O input function call.

For example, the 6 GPIO functions:

GPIO_0 to GPIO_2 are mapped as the input functions, and GPIO_4 to GPIO_6 are mapped as the output functions.

In this case, the parameter for “SetDioInputMask” is 0x07 and it indicates that GPIO_0 to GPIO_2 are the input functions.

The parameter for “SetDioOutputMask” is 0x70 and it indicates that GPIO_4 to GPIO_6 are the output functions.

Output : Dummy data and should be ignored.

```
extern "C" __declspec(dllexport) int __stdcall SetDioOutputMask(int);
```

Input : Hardware parameter for digital I/O output function call

For further information, refer to the following explanation of “SetDioInputMask” routine.

SetDioInputMask:

```

if ((*lpIsDioAvailable)(0))
    {
        int DioInput;
        printf(" Test for digital IO ....\n");

        //Please check digital IO setting in BIOS setup utility
        //Here example as follow:
        // Digital GPIO [1..3] = Input
        // Digital GPIO [4..6] = Output

        //set hardware information for GPIO chip
        //bit 0..2 : input for GPIO_0 to GPIO_2
        //bit 4..6 : output for GPIO_4 to GPIO_6
        (*lpSetDioInputMask)(0x07);
        (*lpSetDioOutputMask)(0x70);

        DioInput = (*lpGetDioInput)(0);
        printf(" Current GPIO_0 to GPIO_2 is 0x%X\n", DioInput);

    while(1)
    {
        (*lpSetDioOutput)(0x00);
        printf(" Set GPIO_4 to GPIO_6 to LOW\n");
        (*lpSetDioOutput)(0x70);
        printf(" Set GPIO_4 to GPIO_6 to HIGH\n");
        (*lpSetDioOutput)(0x30);
        printf(" Set GPIO_4 to GPIO_5 to HIGH\n");
        (*lpSetDioOutput)(0x60);
        printf(" Set GPIO_5 to GPIO_6 to HIGH\n");

        Sleep(500);
        if (_kbhit())
            {
                break;
            }
    }//if (kbhit())
    }//while(1)
} //if ((*lpIsDioAvailable)(0))

```

Note: Be sure to set up the input / output for GPIO bits in BIOS identically with the GPIO hardware information above.

E. Motherboard MCU ISP Specifications

1. Description

Security MCU provides following functionality

- **Getting Firmware Version**
Software can get the firmware version, MCU provides commands to get current major Version, minor version and build version.
- **Setting Power-On-Delay Timer**
MCU provides command to set power on delay timer, when arrived the setting time, MCU will send power button to let the system power on.
- **Setting Power-Off-Delay Timer**
MCU provides command to set power off delay timer, when arrived the setting time, MCU will send power button to let the system power off.
- **Setting DC-Off Delay Timer**
MCU provides command to set DC off delay timer, when arrived the setting time, MCU will cut off system power.
- **Setting Low Delay Timer**
MCU provides command to set low delay timer, when car battery or UPS battery voltage is lower than UVP setting voltage, start low delay timer, when arrived the setting time, MCU will send power button to let the system power off.
- **Setting THL Delay Timer**
MCU provides command to set low delay timer, when system temperature is lower than THL low setting temperature or higher than THL max setting temperature, start THL delay timer, when arrived the setting time, MCU will send power button to let the system power off.
- **Setting THL Max Temperature**
MCU provides command to set high temperature protection, when system temperature is higher than THL max setting value, MCU trigger THL delay timer.
- **Setting THL Low Temperature**
MCU provides command to set low temperature protection, when system temperature is lower than THL low setting value, MCU trigger THL delay timer.

- **Setting CB UVP Voltage**
MCU provides command to set under voltage protection of car battery, when car battery voltage is lower than CB UVP setting value, MCU will check the voltage of UPS battery whether change power source to UPS battery or not.
- **Setting PB UVP Voltage**
MCU provides command to set under voltage protection of UPS battery, when UPS battery voltage lower than PB UVP setting value, MCU will check the voltage of car battery whether change power source to car battery or not.
- **Setting CB Good Voltage**
MCU provides command to set CB good voltage protection of car battery, when CB voltage level higher than CB good voltage start charging UPS battery.
- **Setting PB Good Voltage**
MCU provides command to set PB good voltage protection of UPS battery, when system on and car battery voltage lower than CB good and UPS battery voltage higher than PB good. System will change power source to UPS battery.
- **Getting current CB & PB Voltage**
MCU provides command to get current car battery voltage and UPS battery voltage.
- **Setting CHG STV Voltage**
MCU provides command to set high of UPS battery charging voltage range, when system on and UPS battery voltage higher than CHG STV. System will charge UPS battery.
- **Setting CHG SPV Voltage**
MCU provides command to set UPS battery charging range, when system on and UPS battery voltage lower than CHG SPV. System discharge UPS battery.
- **Setting Temperature Offset**
MCU provides command to set temperature offset. It can adjust temperature disparity between system and power board.
- **Setting CB Voltage Offset**
MCU provides command to set car battery voltage offset. It can adjust this voltage disparity between actual measurement and detected from MCU.

iBASE

- **Setting PB Voltage Offset**

MCU provides command to set UPS battery voltage offset. It can adjust this voltage disparity between actual measurement and detected form MCU.

- **Getting status**

MCU provides command to get current status which includes the power on delay timer setting, power off delay timer setting, low delay setting value, DC off timer value, temperature protect setting value, voltage protect setting value, Car battery & UPS battery voltage offset setting value, UPS battery charge voltage setting value and current Car battery (CB) & UPS battery(PB) voltage and current temperature of power board.

Note: Before using the ISP, your software engineer has to make sure the firmware version (GET_FORMWARE_VERSION) MUST be as follows to make the ISP function workable.

Major version is 0.

Minor version is 0.

Build version is 5 (or above).

2. Protocol

- **Signal transmit format**

Bandwidth

Baud rate: 19200 bps

Data Format

Parity: No Parity

1 start bit

8 data bits

1 stop bit

- **Packet Format**

Header	Size	Command	Data	CRC
2 bytes	1 byte	1 byte	0 – 64 bytes	2 bytes

Header bytes indicate start of the packet.

Size specifies number of bytes for data field.

Command identifies action, which is required to be performed on the data.

CRC verifies data integrity for header, size, command and data bytes.

- **CRC**

Protocol uses 16-bit CCITT CRC to verify data integrity.

$$P(x) = X^{16} + X^{12} + X^5 + 1$$

```

unsigned calc_crc(unsigned char *data, unsigned n, unsigned start) {
    unsigned l, k, q, c, crcval;
    crcval=start;
    for (l=0; l<n; l++) {
        c=data(l) & 0xFF;
        q=(crcval^c) & 0x0F;
        crcval=(crcval>>4)^(q*0x1081);
        q=(crcval^(c>>4)) & 0x0F;
        crcval=(crcval>>4)^(q*0x1081);
    }
    return crcval;
}

```

- **Communications flow**

Communication between PC and Security MCU utilizes Master-Slave model, where PC is a master, and Security MCU is a slave. Master sends requests to the slave, and slave has to reply to them. Slave acts like a passive device and cannot send any requests to the master.

3. Command and Reply Codes

- **Summary**

Code	Value	Description
GET_FIRMWARE_VERSION	0x01	Get Firmware version
SET_POWER_ON_DELAY_TIMER	0x04	Power on delay timer setting
SET_POWER_OFF_DELAY_TIMER	0x05	Power off delay timer setting
GET_STATUS	0x10	Get Current Status

- **Getting Firmware Version**

Parameter: GET_FIRMWARE_VERSION

Reads version number of the security MCU firmware.

Request:

Header	Size	Command	Data	CRC
0xFF 0xEE	0x00	GET_FIRMWARE_VERSION	None	

Reply:

Header	Size	Command	Data	CRC
0xFF 0xEE	Size of Version structure	GET_FIRMWARE_VERSION	BSL Version Structure	

BSL Version Structure

Field	Type	Description
Major Version	Byte	Major version number
Minor Version	Byte	Minor version number
Build	Byte	Build version number

- **Setting Power-On Delay Timer**

Parameter: SET_POWER_ON_DELAY_TIMER

Sets power on delay timer.

Request:

Header	Size	Command	Data0	Data1	CRC
0xFF 0xEE	0x02	SET_POWER_ON_DELAY_TIMER	N (mins)	N (secs)	

Reply

Header	Size	Command	Data	CRC
0xFF 0xEE	0x00	SET_POWER_ON_DELAY_TIMER	None	

- **Setting Power-Off Delay Timer**

Parameter: SET_POWER_OFF_DELAY_TIMER

Sets power off delay timer.

Request:

Header	Size	Command	Data0	Data1	CRC
0xFF 0xEE	0x02	SET_POWER_OFF_DELAY_TIMER	N (mins)	N (secs)	

Reply

Header	Size	Command	Data	CRC
0xFF 0xEE	0x00	SET_POWER_OFF_DELAY_TIMER	None	

- **Getting Status**

Get the power-on-delay timer and power-off-delay timer.

Request:

Header	Size	Command	Data	CRC
0xFF 0xEE	0x00	GET_STATUS	None	

Reply:

Header	Size	Command	Data	CRC
0xFF 0xEE	0x04	GET_STATUS	Status structure	

BSL Version Structure

Field	Type	Description
Power on delay timer	Word	Byte4+ Byte5
Power off delay timer	Word	Byte6+ Byte7