

MBB1002

**eATX Motherboard
with AMD EPYC™
Embedded 8004
Series Processors**

User Manual

Version 1.0A
March 2026



Copyright

© 2026 IBASE Technology, Inc. All rights reserved.

No part of this publication may be reproduced, copied, stored in a retrieval system, translated into any language or transmitted in any form or by any means, electronic, mechanical, photocopying, or otherwise, without the prior written consent of IBASE Technology, Inc. (hereinafter referred to as "IBASE").

Disclaimer

IBASE reserves the right to make changes and improvements to the products described in this document without prior notice. Every effort has been made to ensure the information **in this document** is correct; however, IBASE does not guarantee that it is error-free.

IBASE assumes no liability for incidental or consequential damages arising from misapplication or inability to use the product or the information contained herein, nor for any infringements of rights of third parties, which may result from its use.

Trademarks

All the trademarks, registered trademarks and brands mentioned herein are used for identification purposes only and may be trademarks and/or registered trademarks of their respective owners.

Compliance



This product has passed CE compliance testing and conforms to applicable EU directives. In a domestic environment, it may cause radio interference, requiring users to take appropriate measures.



This product complies with the limits for a Class B digital device, pursuant to Part 15 of the FCC Rules. It generates, uses, and can radiate radio frequency energy. If not installed and used according to the manufacturer's instructions, it may cause harmful interference to radio communications.

WEEE



This product must not be disposed of as normal household waste, in accordance with the EU directive on Waste Electrical and Electronic Equipment (WEEE - 2012/19/EU). Instead, it should be disposed of by returning it to a municipal recycling collection point. Check local regulations for disposal of electronic products.

RoHS Compliance



This product complies with RoHS 2 restrictions, which prohibit the use of certain hazardous substances in electrical and electronic equipment. The following substances must not exceed the specified concentrations:

- Hexavalent chromium: 1,000 ppm
- Polybrominated biphenyls (PBBs): 1,000 ppm
- Polybrominated diphenyl ethers (PBDEs): 1,000 ppm
- Cadmium: 100 ppm
- Mercury: 1,000 ppm
- Lead: 1,000 ppm
- Bis(2-ethylhexyl) phthalate (DEHP): 1,000 ppm
- Butyl benzyl phthalate (BBP): 1,000 ppm
- Dibutyl phthalate (DBP): 1,000 ppm
- Diisobutyl phthalate (DIBP): 1,000 ppm

Important Safety Information

Carefully read the precautions before using the board.

Care and Handling Guidelines:

- Before cleaning the PCB, ensure the device is unplugged and powered off.
- If cleaning is required, use approved electronic circuit board cleaner and ensure the board is completely dry before reconnecting power.
- Use a computer-grade vacuum cleaner designed for electronic equipment to remove dust.



Warning

Attention during use:

- Do not use this product near water.
- Do not spill water or any other liquids on this product.
- Do not place heavy objects on the product, as this may damage internal components or affect performance.

Anti-static precautions

- Wear an anti-static wrist strap to avoid electrostatic discharge.
- Place the board on an anti-static mat.
- Handle the board by its edges and avoid touching components or circuitry.
- Ground yourself by touching a grounded metal object, such as a metal pipe or grounded equipment, to discharge static.

Caution:

Risk of explosion if the battery is replaced by an incorrect type. Replace only with the same or equivalent type recommended by the manufacturer. Dispose of used batteries according to the manufacturer's instructions or recycle them at a local recycling facility or battery collection point.

Warranty Policy

- **IBASE standard products:**

24-month (2-year) warranty from the date of shipment. If the shipment date cannot be determined, the product serial number will be used to estimate the shipping date.

- **Third-party components:**

12-month (1-year) warranty from delivery for the third-party components that are not manufactured by IBASE, such as CPU, CPU cooler, memory, storage devices, power adapter, panel and touchscreen.

- * Products that fail due to misuse, accident, improper installation or unauthorized repair shall be treated as out of warranty and customers shall be billed for repair and shipping charges.

Technical Support & Services

1. Visit the IBASE website at www.ibase.com.tw to find the latest information about the product.
2. If you need any further assistance from your distributor or sales representative, prepare the following product information and provide a detailed description of the issue.
 - Product model name
 - Product serial number
 - Detailed description of the problem
 - Any error messages (text or screenshots)
 - The arrangement of the peripherals
 - Software in use (such as OS and application software, including the version numbers)
3. If repair service is required, please visit the IBASE website to apply for an RMA number.

Table of Contents

Chapter 1	General Information.....	1
1.1	Introduction	2
1.2	Features.....	2
1.3	Packing List.....	3
1.4	Specifications	3
1.5	Block Diagram.....	5
1.6	Product View	6
1.7	Dimensions	8
Chapter 2	Hardware Configuration	9
2.1	Essential Installations	10
2.1.1	Installing the Memory	10
2.2	Setting the Jumpers.....	11
2.3	Jumper & Connector Locations.....	12
2.4	Jumpers Quick Reference	13
2.4.1	JP1: Clear CMOS Contents.....	13
2.4.2	JP2: ATX/AT Mode Setting (Debug use)	14
2.5	Connectors Quick Reference.....	15
2.5.1	U1: CPU Socket	16
2.5.2	U37, U38, U39, U40, U41, U42: RDIMM Socket.....	17
2.5.3	PCIE1, PCIE2, PCIE3, PCIE4, PCIE5: PCIE x16 slot.....	17
2.5.4	J2: Front Panel Header	18
2.5.5	J3: Dual-port USB 2.0 Header	19
2.5.6	J8, J9, J18: ATX Power Connector	20
2.5.7	J10, J13: MCIO Connector	21
2.5.8	J12: M.2 M-Key 2280 Slot	21
2.5.9	CN3, CN4, CN7, CN8: SATA Connector	22
2.5.10	FAN1: CPU FAN Connector	22
2.5.11	FAN2, FAN3, FAN4: System Fan Connector	23
2.5.12	BT1: RTC Battery Socket	24
2.5.13	ATX1: ATX 24-pin Power Connector	25
2.5.14	SW4: Power Button	26
2.5.15	LED14 : Status/HDD/Power LED.....	26
2.5.16	CN9: Single Port 10 Gigabit LAN (Intel X710-AT2).....	27
2.5.17	CN10: Single Port 10 Gigabit LAN (Intel X710-AT2)	27
2.5.18	CN11: Dual Ports USB 3.2 Gen1 Connector.....	28

2.5.19	CN12: Console	29
2.5.20	J6: IDA101 PWR Connector (Debug use)	30
2.5.21	J7: VR Debug Header (Debug use)	31
2.5.22	SW1: Reset Button (Debug use)	32
2.5.23	SW2: Power Button (Debug use)	32
2.5.24	J11: CPU Debug Header (Debug use)	33
2.5.25	JP3: FPGA JTAG Header (Debug use)	33
2.5.26	J14: FPGA SPI Flash Connector (Debug use)	34
2.5.27	J15: eSPI 80 Port Debug connector (Debug use)	34
2.5.28	J16: X710-AT2 SPI Flash Connector (Debug use)	35
2.5.29	J17: X710-AT2 Debug Mode (Debug use)	35
2.5.30	J20: BIOS SPI Flash Connector (Debug use)	36

Chapter 3 BIOS Setup.....37

3.1	Introduction	38
3.2	BIOS Setup	38
3.3	Main Settings	39
3.4	Advanced Settings	40
3.5	Chipset Settings	55
3.6	Security Settings	56
3.7	Boot Settings	58
3.8	Save & Exit Settings	59

Chapter 1

General Information

The information provided in this chapter includes:

- Features
- Packing List
- Specifications
- Block Diagram
- Product View
- Dimensions

1.1 Introduction

MBB1002 is an eATX motherboard powered by AMD EPYC™ Embedded 8004 Series processors. Designed for server-class and embedded applications, it supports six DDR5 memory channels with up to 576GB ECC RDIMM memory, delivering high reliability and performance for mission-critical workloads.

The platform provides extensive expansion capability with five PCIe x16 slots and high-speed storage support, including one PCIe Gen5 M.2 slot (2280) and two MCIO x4 connectors. For networking, MBB1002 integrates dual 10 Gigabit Ethernet connectivity via Intel® X710-AT2 controllers. Additional I/O features include four SATA 6Gb/s ports and USB 3.2 Gen1 interfaces with PDPC (PDPC: Power Delivery Port Control) support, making the board well suited for data-intensive, edge computing, networking, and enterprise embedded applications.



1.2 Features

- AMD EPYC Embedded 8004 Series CPU
- 6x DDR5 RDIMM, up to 4800MT/s, up to 576GB ECC†
- 5x PCIe x16 slots
- 2x (USB 3.2 Gen1) with PDPC Support
- 4x SATA 6Gb/s
- 1x PCIe Gen5 2280, 2x MCIO x4
- 2x Intel® X710-AT2 (Dual 10GbE port)

1.3 Packing List

Your MBB1002 package should include the items listed below. If any item is missing, contact the distributor or dealer from whom you purchased the product.

- MBB1002 x 1
- IO Shield x 1
- SATA cable x 1
- COM cable x 1

1.4 Specifications

Model	MBB1002
Form Factor	eATX Motherboard
Dimensions	330mm x 304mm (12.9 in x 12 in)
CPU Socket	AMD SP6 LGA 4844 (EPYC SP6 processors)
CPU Type	AMD EPYC Embedded 8004 series
PCH	N/A
Memory	Six-channel DDR5, 6 x RDIMM slots, supports ECC, up to 576GB, DDR5-3600/4000/4F x 710400/4800, 16GB/32GB/64GB/96GB RDIMM
BIOS	AMI
Watchdog Timer	256 levels
H/W Monitor	Yes
Storage Device Interface	<ul style="list-style-type: none"> • 4x SATA (6Gb/s) • NVMe: 1x 2280 (PCIe Gen5) • NVMe: 2x M.2 x4 (tested with Gen5 SSD)
Graphics	N/A
Display	N/A
Image Capture Interface	N/A
Video Codec	N/A
I/O Chipset	N/A
External I/O	<ul style="list-style-type: none"> • 3x LED (Power, HDD, Status) • 1x RS-232 (Console) • 2x Intel X710-AT2 • 2x USB 3.2 Gen1 with PDPC support

Internal I/O	<ul style="list-style-type: none">• 2x USB 2.0 (pin header)• 4x SATA 6Gb/s; 1x M.2 2280 (PCIe Gen5)• 1x 24-pin SSI power• 3x 8-pin SSI 12V power• 4x 4-pin fan headers (3 system + 1 CPU)• 1x SMBus
Expansion I/O	5x PCIe x16 slots (Gen5.0)
TPM	TPM 2.0
OS Support	<ul style="list-style-type: none">• Ubuntu 22.04; Windows Server 2022• Windows Server 2025 <i>Note: Supported operating systems include Ubuntu 22.04 and Windows Server 2022/2025. Drivers are included within the supported OS distributions.</i>
Certification	CE, FCC Class B, LVD, RoHS 2.0

Environment	
Operating Temperature	0°C ~ 60°C (32°F ~ 140°F)
Storage Temperature	-20°C ~ 80°C (-4°F ~ 176°F)
Relative Humidity	0% ~ 90% (non-condensing @60°C)

All specifications are subject to change without prior notice.

1.5 Block Diagram

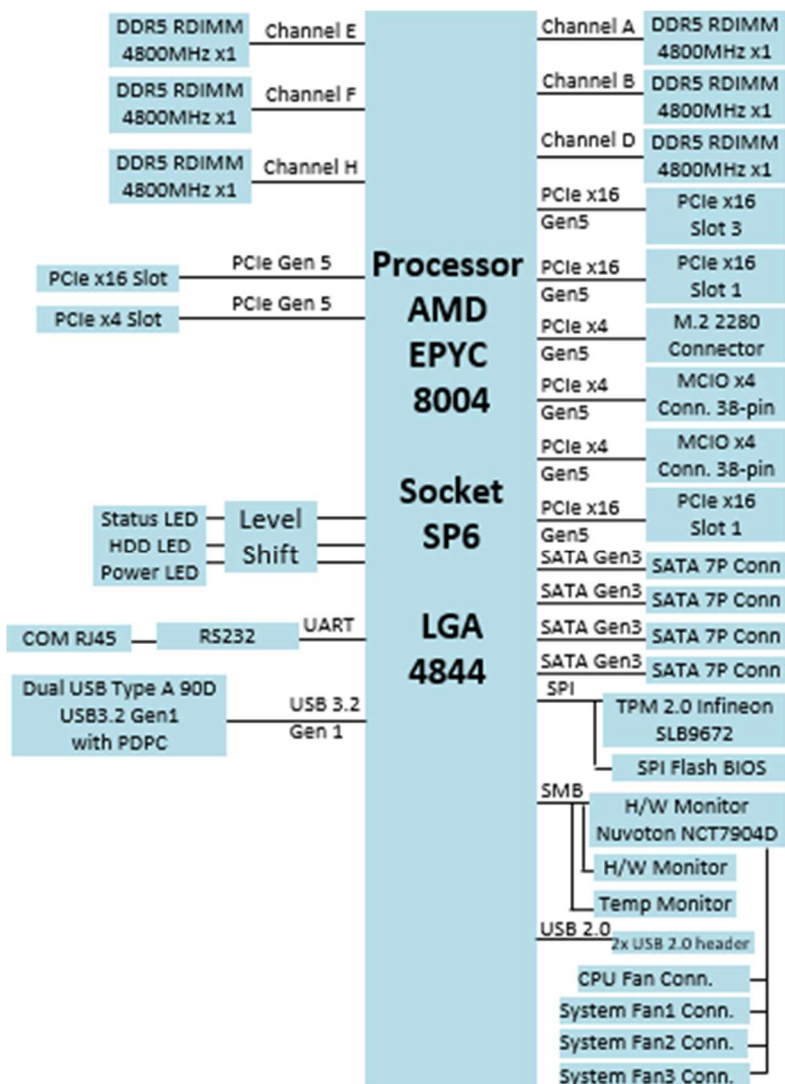

iBASE

1.6 Product View

Top View

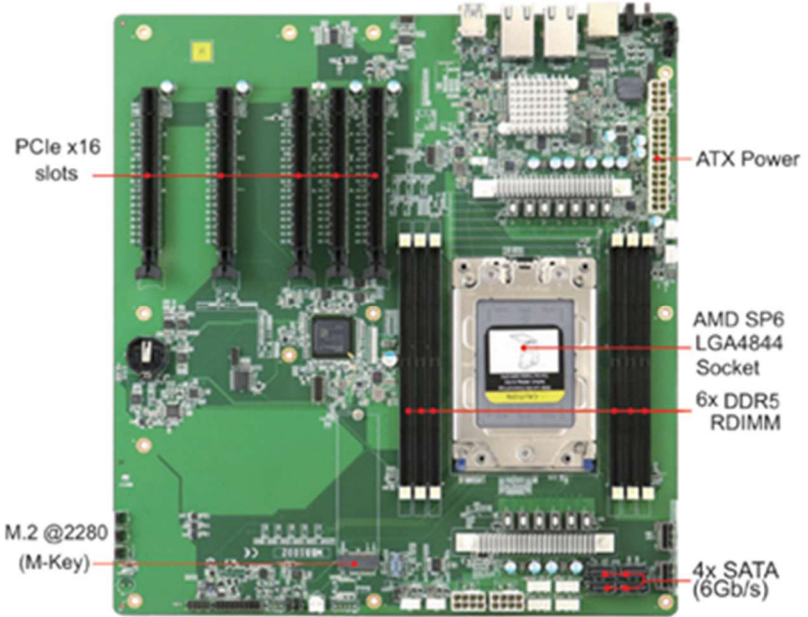

I/O View

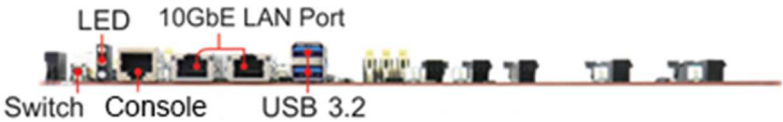

Oblique View



1.7 Dimensions

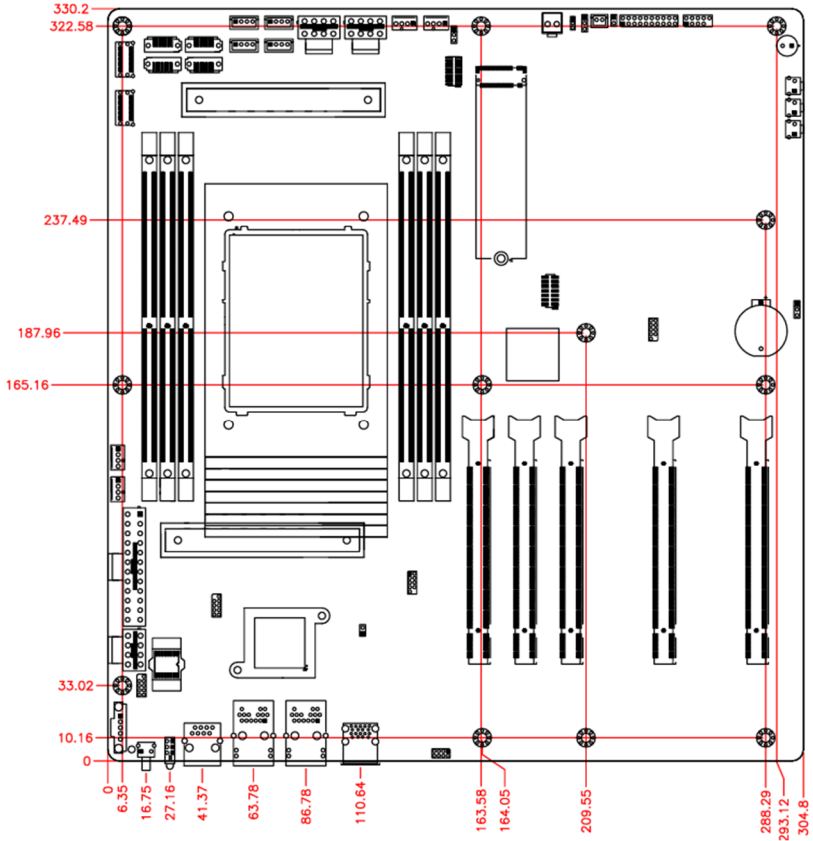

Chapter 2

Hardware Configuration

This section provides information on jumper settings and connectors on the MBB1002 and other installation information necessary for setting up a functional system. The topics covered are:

- Essential installations
- Jumper and connector locations
- Jumper settings and connector descriptions

2.1 Essential Installations

Follow the instructions below to install the memory modules.

2.1.1 Installing the Memory

To install the modules:

1. Locate the memory slots on board.
2. Align the key of the memory module with the ridge in the memory slot then insert the module at a slight angle.



3. Gently push the module in an upright position until the clips on both ends lock into place, securing the module when it is fully seated.

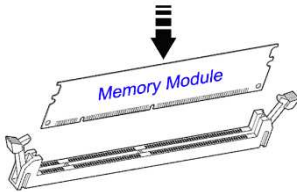

To remove the module, press both ejector tabs outwards to release the module from the slot.

2.2 Setting the Jumpers

Configure the MBB1002 by using jumpers for various settings and features. If you are unsure about the optimal configuration for your application, please consult your supplier or distributor.

Jumpers are short-length conductors made of metal pins mounted on a non-conductive base on the circuit board. Jumper caps are placed over the pins to either enable or disable specific functions. For 3-pin jumpers, you may connect: **Pin 1-2** or **Pin 2-3**.

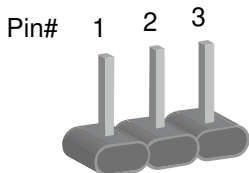

A 3-pin jumper

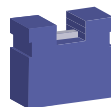

A jumper cap

Refer to the illustration below to set jumpers.

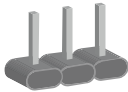
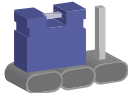
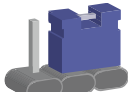
Jumper	Pin Configuration	Description
	Pins open	Jumper is open (function is disabled)
	Pins 1-2 closed	Jumper is closed on pins 1-2
	Pins 2-3 closed	Jumper is closed on pins 2-3

When two pins of a jumper are encased in a jumper cap, this jumper is **closed**, i.e., turned **On**.

When a jumper cap is removed from two jumper pins, this jumper is **open**, i.e., turned **Off**.

2.4 Jumpers Quick Reference

Jumper	Function
JP1	Clear CMOS Contents
JP2	ATX/AT Mode Setting

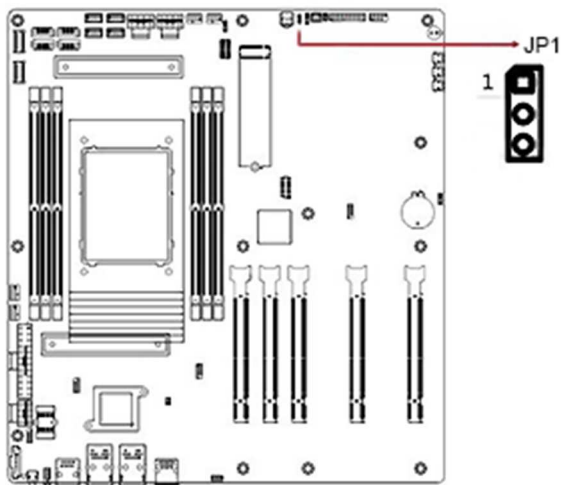

2.4.1 JP1: Clear CMOS Contents

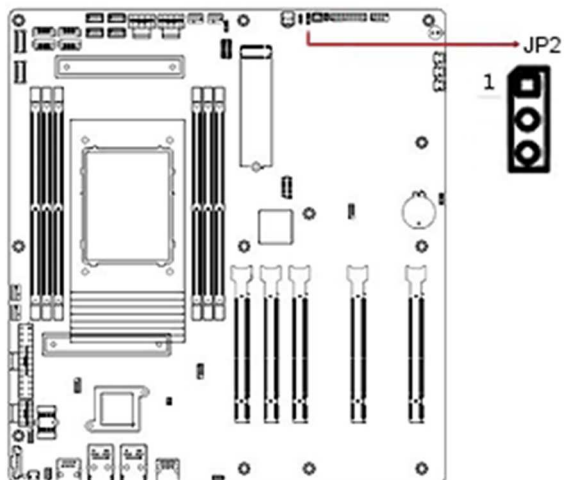

Function	Pin closed	Illustration
Normal (default)	1-2	1
Clear CMOS	2-3	1

2.4.2 JP2: ATX/AT Mode Setting (Debug use)



Mode	Pin closed	Illustration
AT(Default)	1-2	1 
ATX	2-3	1 

2.5 Connectors Quick Reference

Connector	Function
U1	CPU Socket
U37, U38, U39, U40, U41, U42	RDIMM Socket
PCIE1, PCIE2, PCIE3, PCIE4, PCIE5	PCIe x16 Slot
J2	Front Panel Header
J3	Dual Ports USB 2.0 Header
J8, J9, J18	ATX Power Connector
J10, J13	MCIO Connector
J12	M.2 M-Key 2280 Slot
CN3, CN4, CN7, CN8	SATA Connector
FAN1	CPU Fan Connector
FAN2, FAN3, FAN4	System Fan Connector
BT1	RTC Battery Socket
ATX1	ATX 24-pin Power Connector
SW4	Power Button
LED14	Status / HDD / Power LED
CN9	Single Port 10 Gigabit LAN (Intel X710-AT2)
CN10	Single Port 10 Gigabit LAN (Intel X710-AT2)
CN11	Dual Ports USB 3.2 Gen1 Connector
CN12	Console
J6	IDA101 PWR Connector (Debug use)
J7	VR Debug Header (Debug use)
SW1	Reset Button (Debug use)
SW2	Power Button (Debug use)
J11	CPU Debug Header (Debug use)
JP3	FPGA JTAG Header (Debug use)
J14	FPGA SPI Flash Connector (Debug use)
J15	eSPI 80 Port Debug Connector (Debug use)
J16	X710-AT2 SPI Flash Connector (Debug use)
J17	X710-AT2 Debug Mode (Debug use)
J20	BIOS SPI Flash Connector (Debug use)

2.5.1 U1: CPU Socket

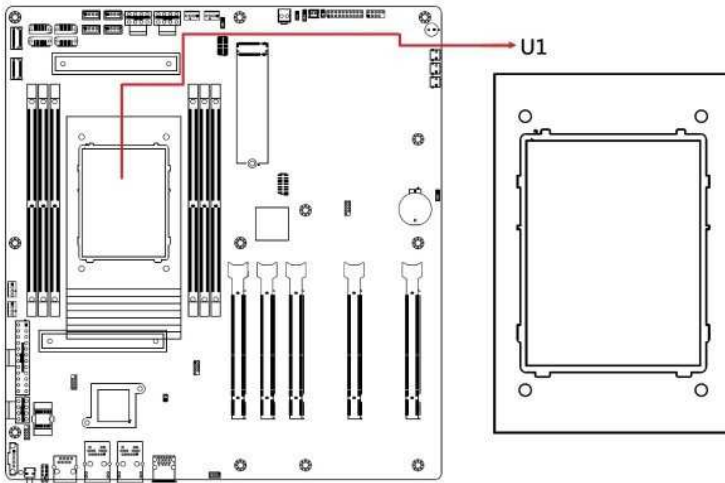

- **CPU Type**
- AMD SP6 LGA 4844 (EPYC SP6 Processor)
- 8534P (TDP 200W, 64 Cores, 2.3GHz~3.1GHz, 128MB L3 cache)
- 8434P (TDP 200W, 48 Cores, 2.5GHz~3.1GHz, 128MB L3 cache)
- 8324P (TDP 180W, 32 Cores, 2.65GHz~3.0GHz, 128MB L3 cache)
- 8224P (TDP 160W, 24 Cores, 2.55GHz~3.0GHz, 64MB L3 cache)
- 8124P (TDP 125W, 16 Cores, 2.45GHz~3.0GHz, 64MB L3 cache)
- 8C24P (TDP 100W, 12 Cores, 2.45GHz~3.0GHz, 32MB L3 cache)

2.5.2 U37, U38, U39, U40, U41, U42: RDIMM Socket

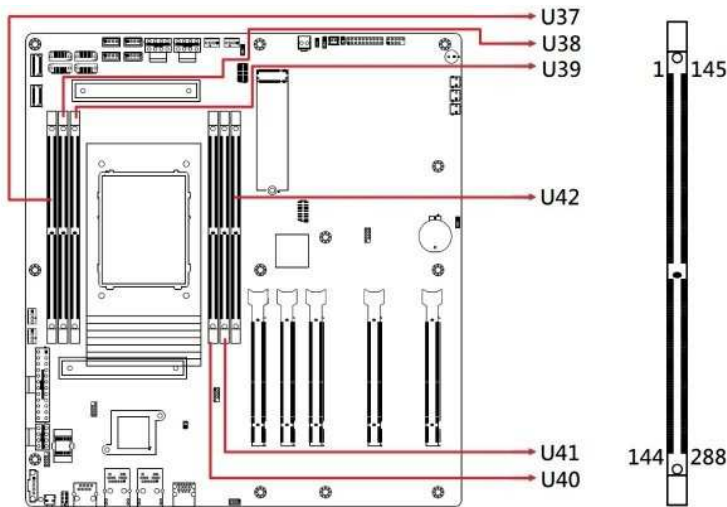

2.5.3 PCIE1, PCIE2, PCIE3, PCIE4, PCIE5: PCIE x16 slot

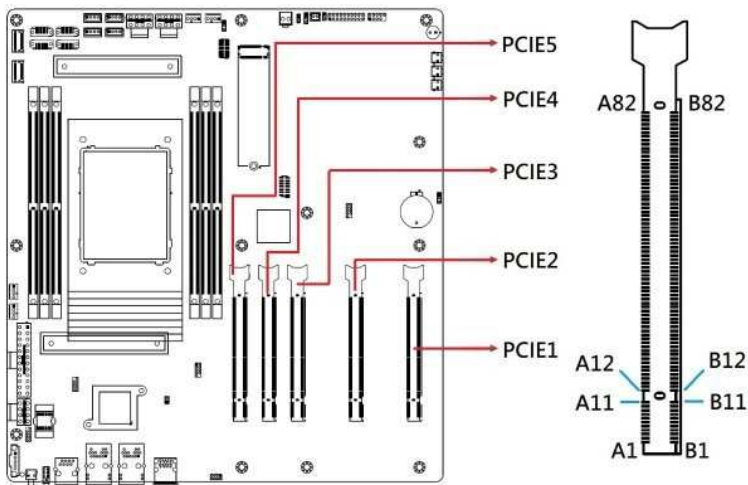

Note: Supports PCIe x16 GEN5

2.5.4 J2: Front Panel Header

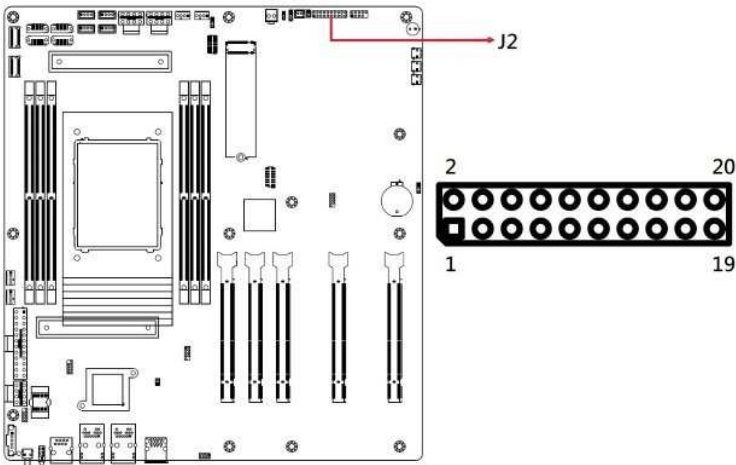

Signal Name	Pin	Pin	Signal Name
PU P5V	1	2	NC
GND	3	4	NC
GND	5	6	GND
NC	7	8	P5V
GND	9	10	NC
GND	11	12	NC
PW	13	14	FPW_OUT
SLED+(PU 5VDUAL)	15	16	SLED-
GND	17	18	FRST_OUT
HD+(PU P3V3)	19	20	-HDLED

Note1: 1-3 OR 1-5 Power LED

Note2: 13-14 Power Button

Note3: 17-18 Reset Button

Note4: 19-20 HDD LED

2.5.5 J3: Dual-port USB 2.0 Header

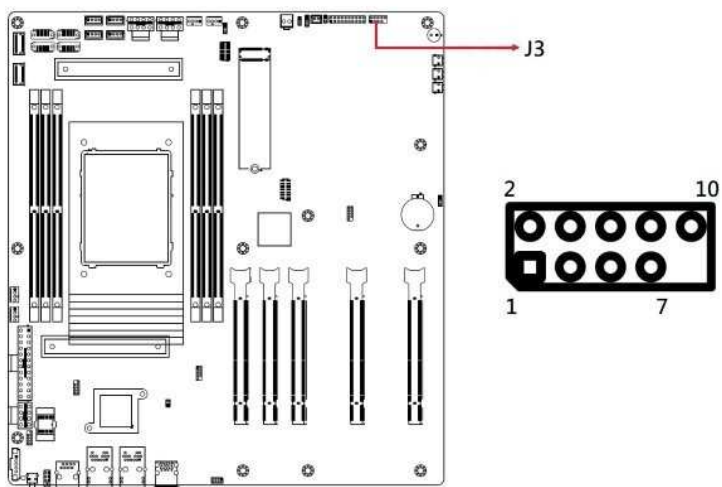

Signal Name	Pin	Pin	Signal Name
VCCCH3(5V)	1	2	VCCCH3(5V)
USB00_DATA_N	3	4	USB01_DATA_N
USB00_DATA_P	5	6	USB01_DATA_P
GND	7	8	GND
none	9	10	NC

2.5.6 J8, J9, J18: ATX Power Connector

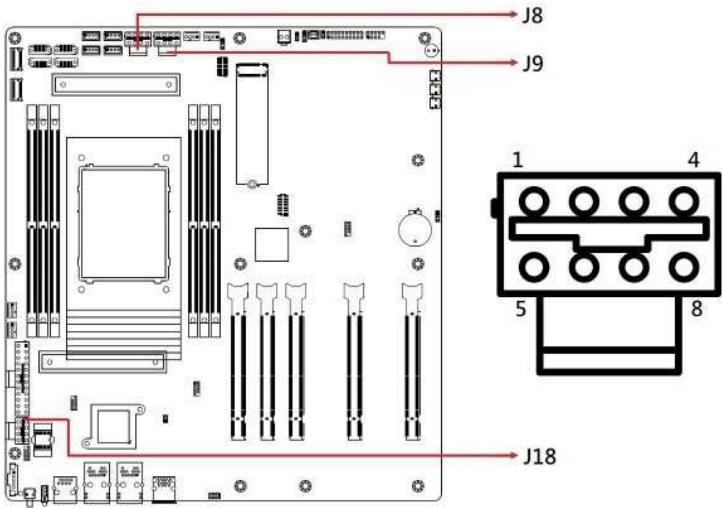

Pin	Signal Name
1	GND
2	GND
3	GND
4	GND
5	P12V
6	P12V
7	P12V
8	P12V

2.5.7 J10, J13: MCIO Connector

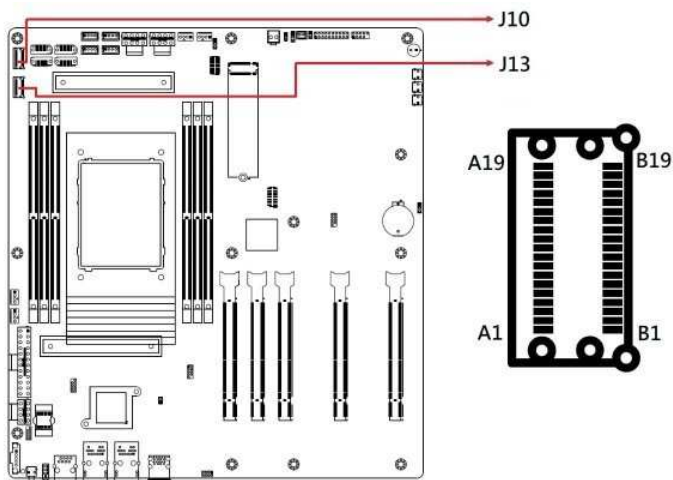

2.5.8 J12: M.2 M-Key 2280 Slot

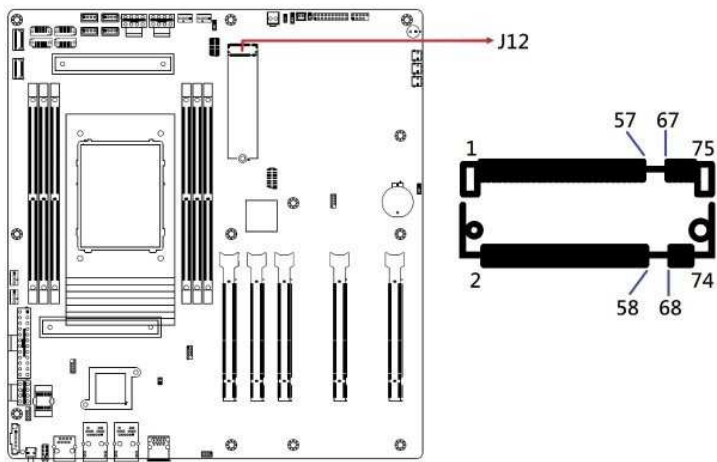

Note: Supports PCIE x4 GEN5

2.5.9 CN3, CN4, CN7, CN8: SATA Connector

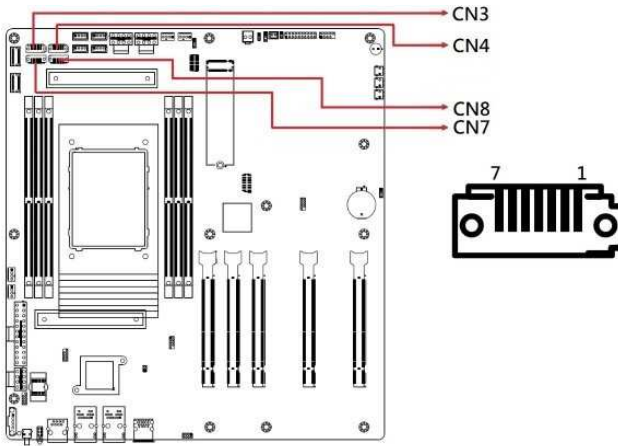

2.5.10 FAN1: CPU FAN Connector

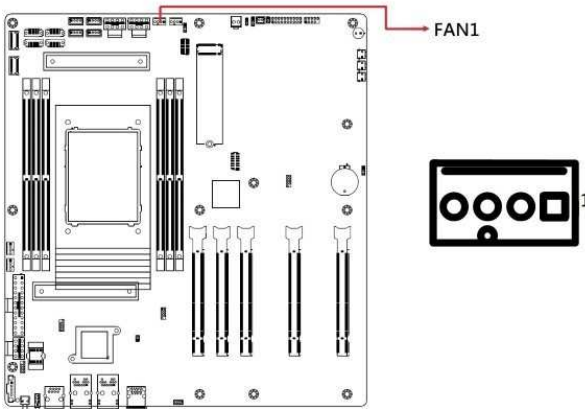

Pin	Signal Name
1	GND
2	12V
3	RPM
4	PWM

2.5.11 FAN2, FAN3, FAN4: System Fan Connector

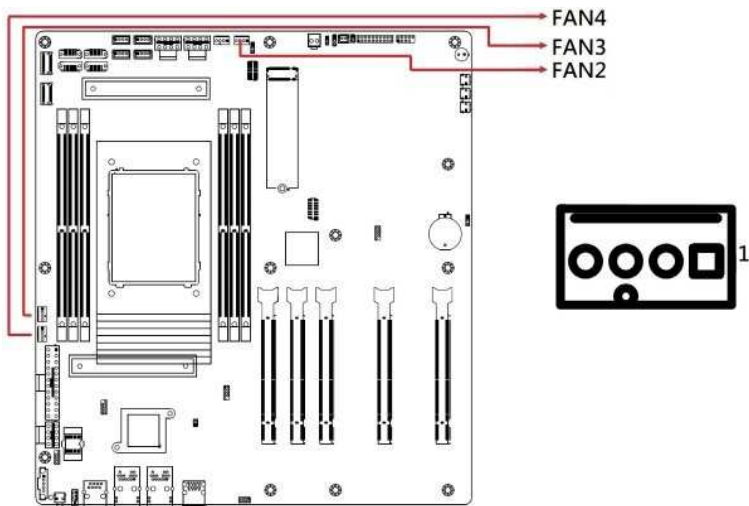

Pin	Signal Name
1	GND
2	12V
3	RPM
4	PWM

2.5.12 BT1: RTC Battery Socket

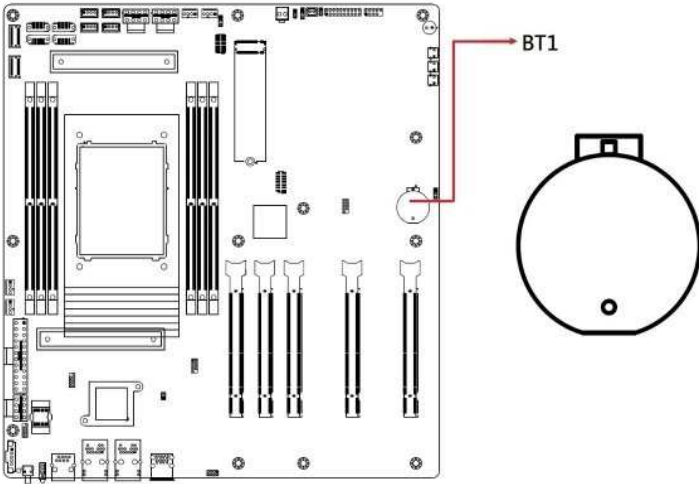

2.5.13 ATX1: ATX 24-pin Power Connector

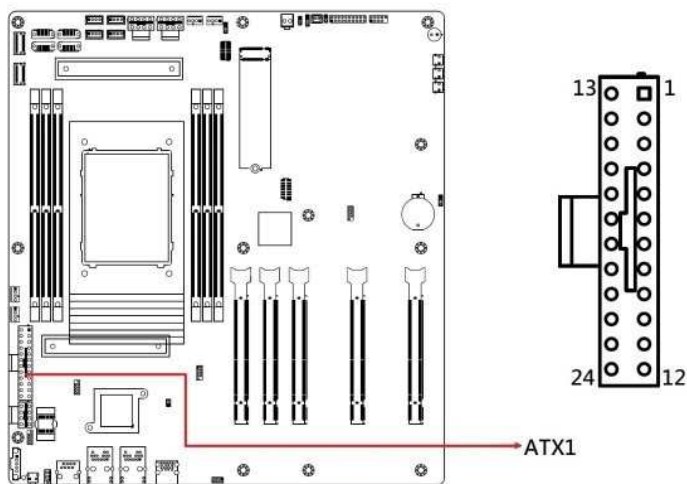

Signal Name	Pin	Pin	Signal Name
P3V3	1	13	P3V3
P3V3	2	14	-12V
GND	3	15	GND
P5V	4	16	PS_ON
GND	5	17	GND
P5V	6	18	GND
GND	7	19	GND
PW_OK	8	20	-12V
5VSB_PS	9	21	P5V
P12V	10	22	P5V
P12V	11	23	P5V
P3V3	12	24	GND

2.5.14 SW4: Power Button

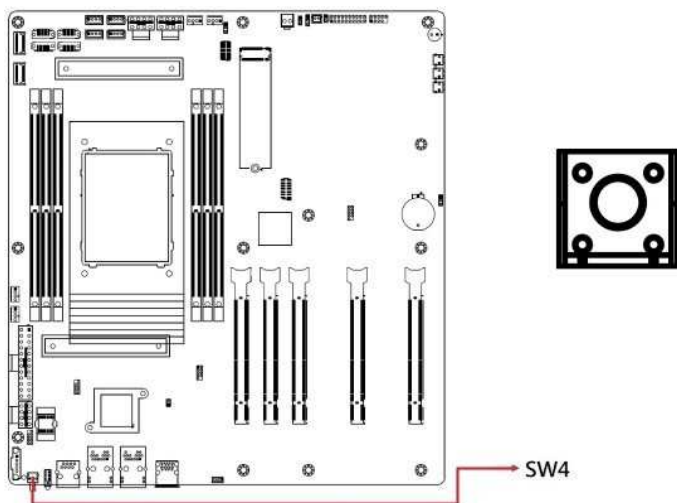

2.5.15 LED14 : Status/HDD/Power LED

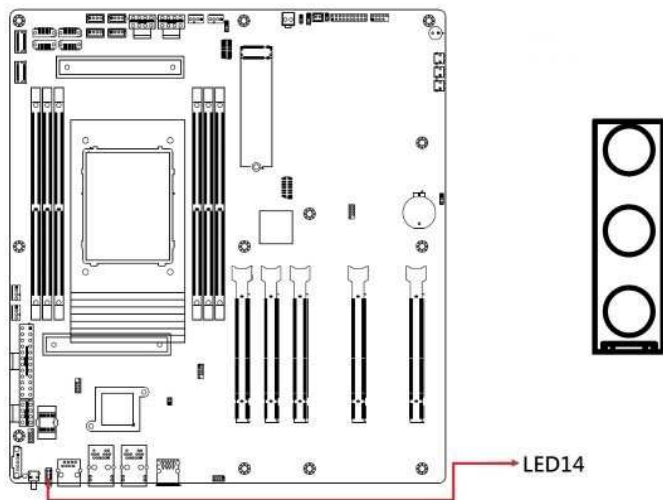

2.5.16 CN9: Single Port 10 Gigabit LAN (Intel X710-AT2)

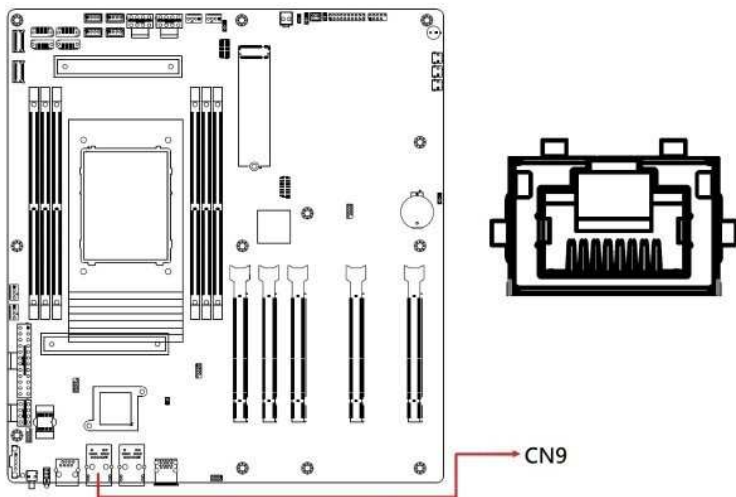

2.5.17 CN10: Single Port 10 Gigabit LAN (Intel X710-AT2)

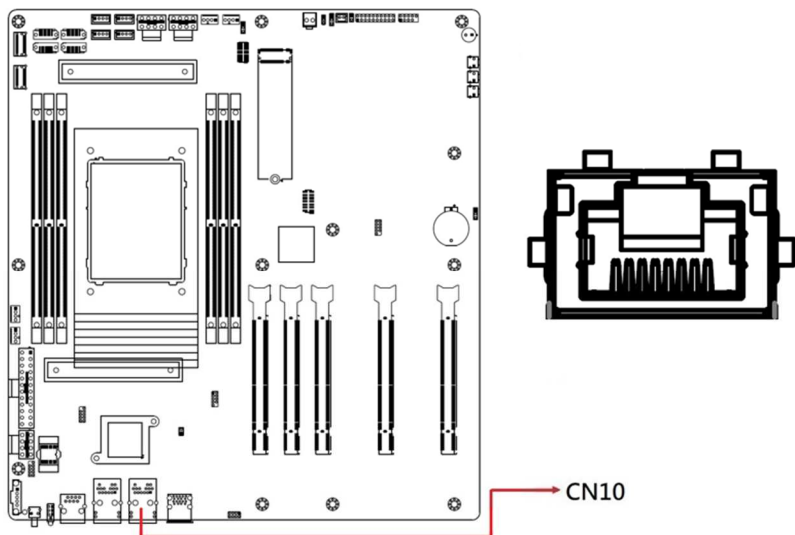

2.5.18 CN11: Dual Ports USB 3.2 Gen1 Connector

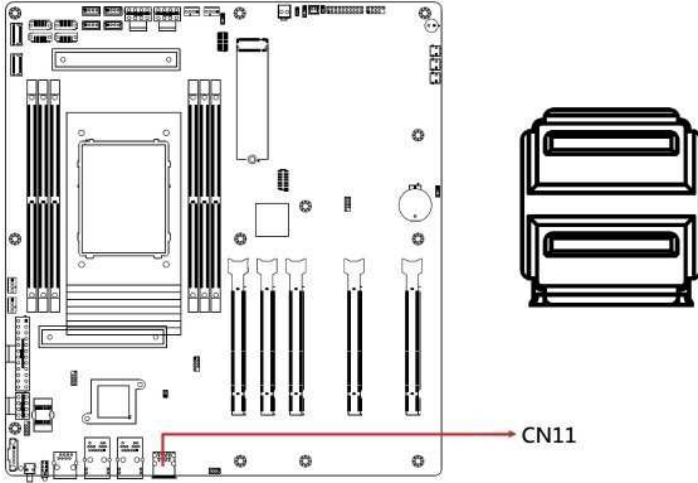

2.5.19 CN12: Console

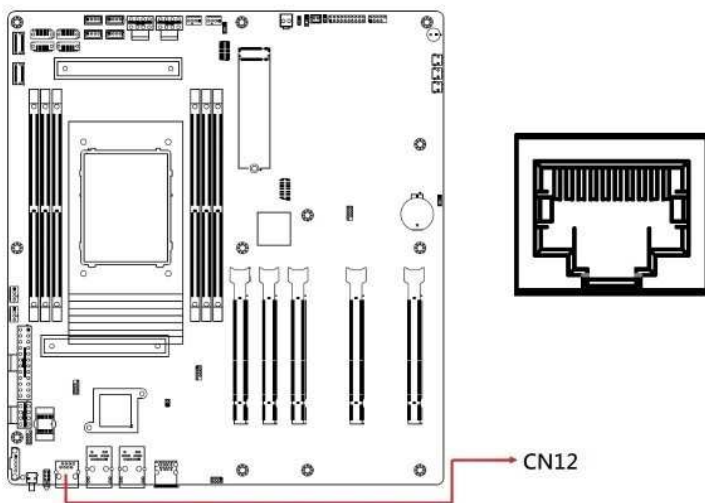

Pin	Signal Name
1	RTS
2	DTR
3	TXD
4	GND
5	GND
6	RXD
7	DSR
8	CTS

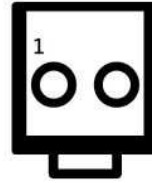
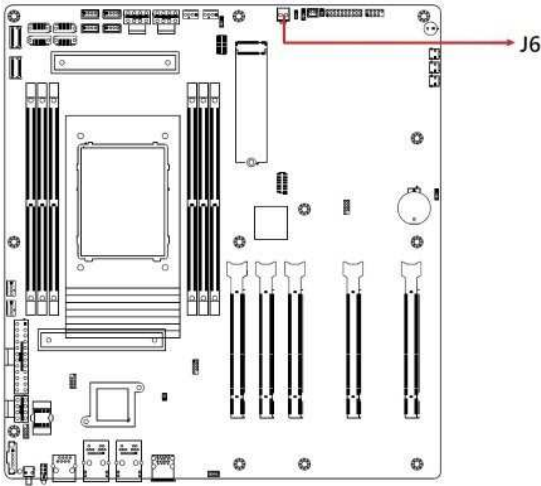
2.5.20 J6: IDA101 PWR Connector (Debug use)

Pin	Signal Name
1	GND
2	P12V

2.5.21 J7: VR Debug Header (Debug use)

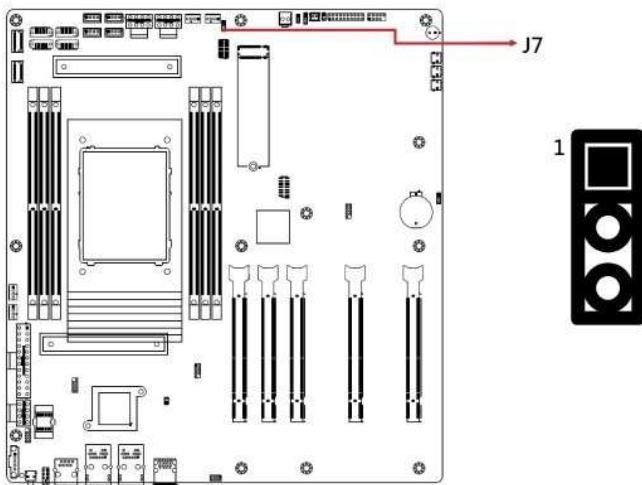

Pin	Signal Name
1	SDA
2	SCL
3	GND

2.5.22 SW1: Reset Button (Debug use)

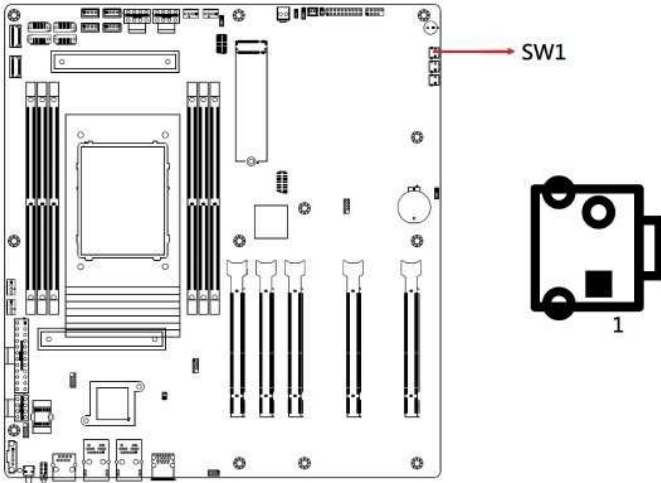

2.5.23 SW2: Power Button (Debug use)

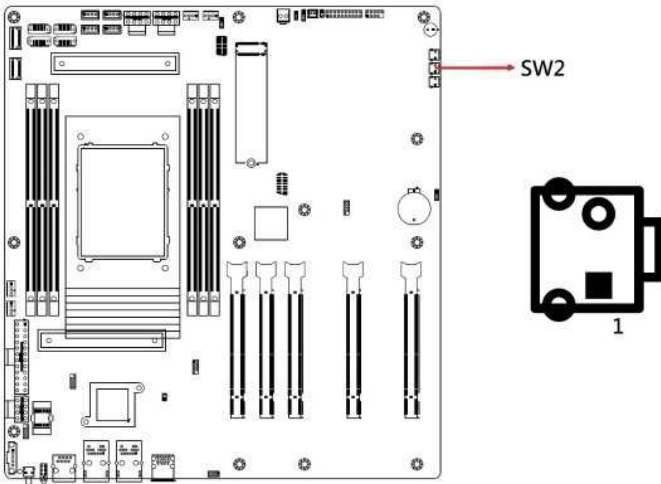

2.5.24 J11: CPU Debug Header (Debug use)

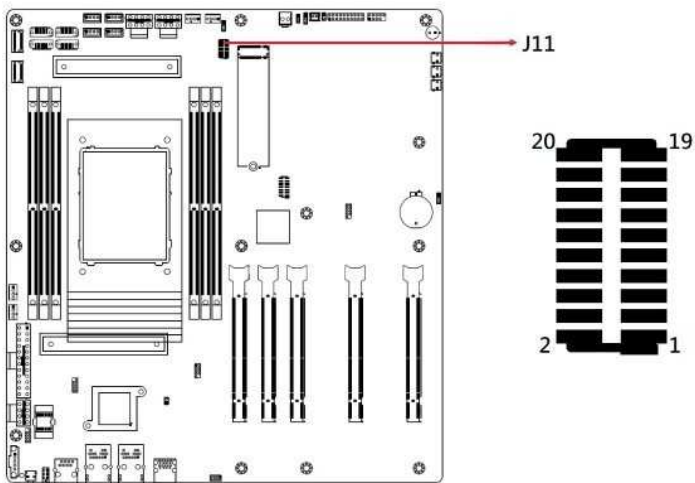

2.5.25 JP3: FPGA JTAG Header (Debug use)

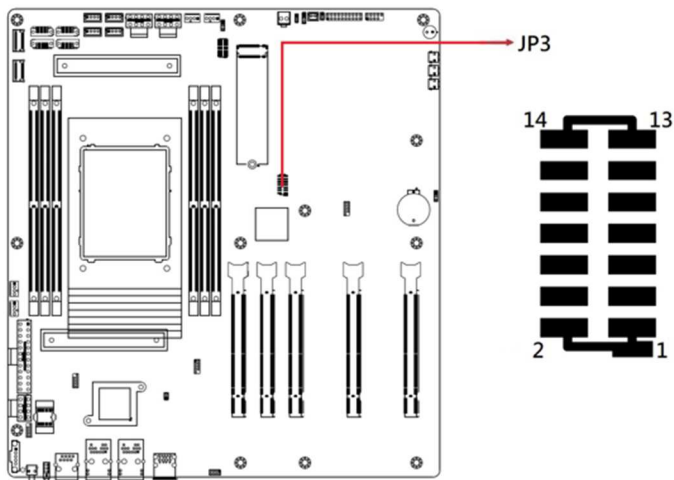

2.5.26 J14: FPGA SPI Flash Connector (Debug use)

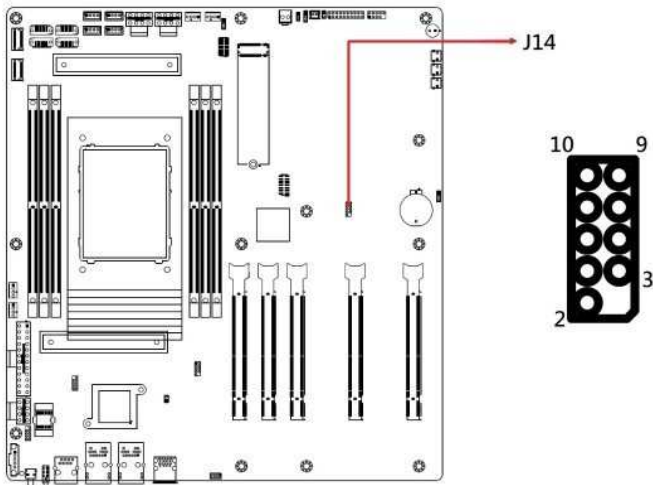

2.5.27 J15: eSPI 80 Port Debug connector (Debug use)

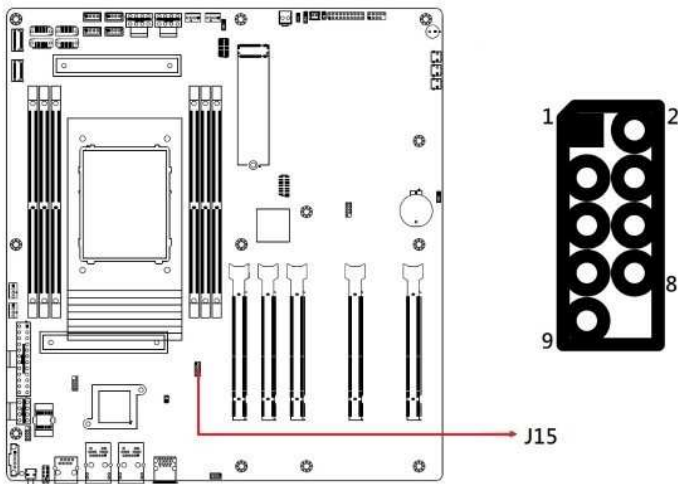

2.5.28 J16: X710-AT2 SPI Flash Connector (Debug use)

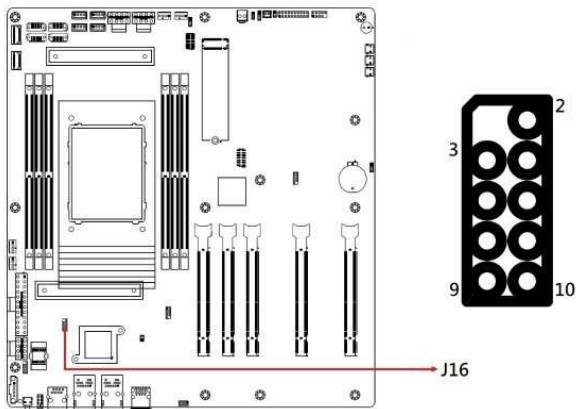

2.5.29 J17: X710-AT2 Debug Mode (Debug use)

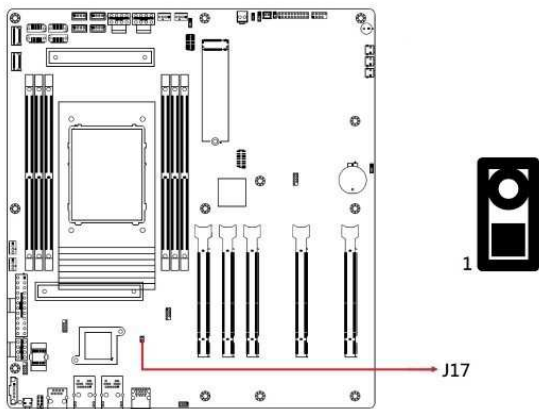

Mode	Pin closed	Illustration
Normal	None	
Debug	1-2	

2.5.30 J20: BIOS SPI Flash Connector (Debug use)

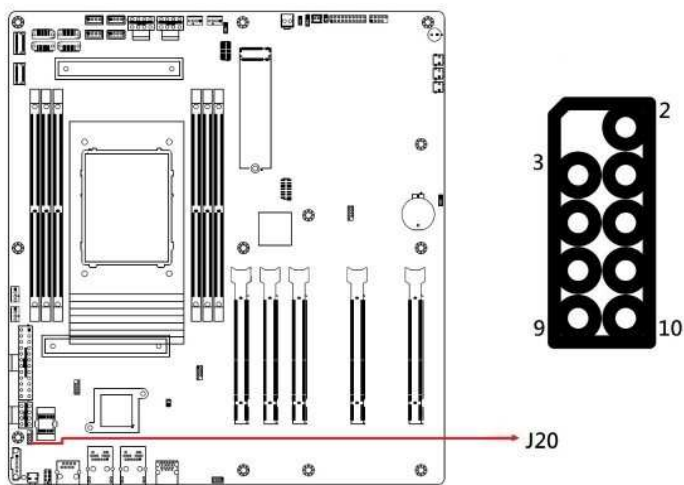

Chapter 3

BIOS Setup

This chapter describes the different settings available in the AMI BIOS that comes with the board. The topics covered in this chapter are as follows:

- Main Settings
- Advanced Settings
- Chipset Settings
- Security Settings
- Boot Settings
- Save & Exit

3.1 Introduction

The BIOS (Basic Input/Output System) installed in the ROM of your computer system provides critical low-level support for standard devices such as disk drives, and serial ports. It also provides password protection as well as special support for detailed fine-tuning of the chipset controlling the entire system.

3.2 BIOS Setup

The BIOS provides a Setup utility program for specifying the system configurations and settings. The BIOS ROM of the system stores the Setup utility. When you turn on the computer, the BIOS is immediately activated. Pressing the key immediately allows you to enter the Setup utility. If you are a little bit late pressing the key, POST (Power On Self Test) will continue with its test routines, thus preventing you from invoking the Setup.

If you still need to enter Setup, restart the system by pressing the "Reset" button or simultaneously pressing the <Ctrl>, <Alt> and <Delete> keys. You can also restart by turning the system Off and back On again.

The following message will appear on the screen:

```
Press <DEL> to Enter Setup
```

In general, press the arrow keys to highlight items, <Enter> to select, the <PgUp> and <PgDn> keys to change entries, <F1> for help, and <Esc> to quit.

When you enter the BIOS Setup utility, the *Main Menu* screen will appear on the screen. The Main Menu allows you to select from various setup functions and exit choices.

Warning: It is strongly recommended that you avoid making any changes to the chipset defaults.

These defaults have been carefully chosen by both AMI and your system manufacturer to provide the absolute maximum performance and reliability. Changing the defaults could make the system unstable and crash in some cases.

3.3 Main Settings



BIOS Setting	Description
System Date	Sets the date. Use the <Tab> key to switch between the data elements.
System Time	Set the time. Use the <Tab> key to switch between the data elements.

3.4 Advanced Settings

This section allows you to configure, improve your system and set up some system features according to your preference.

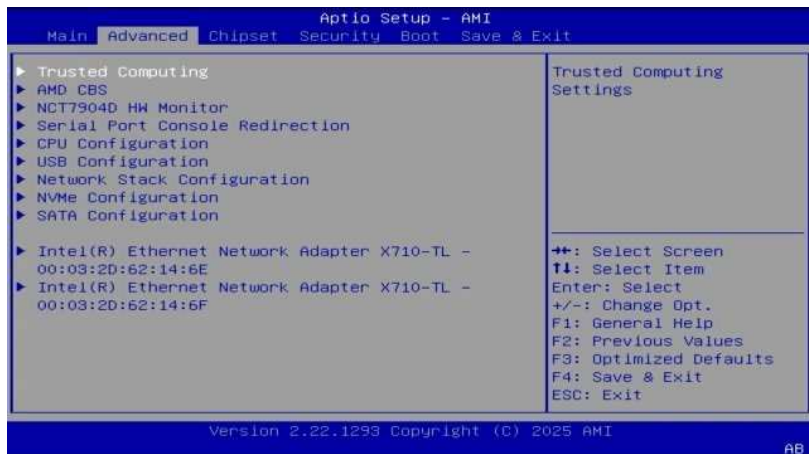

3.4.1 Trusted Computing

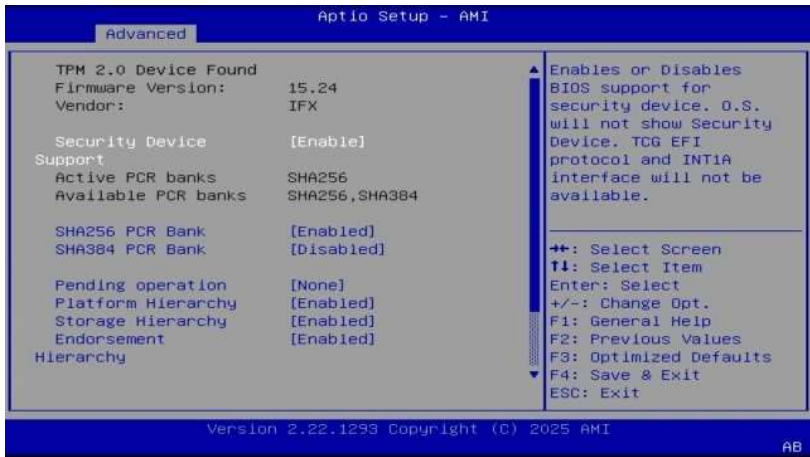

BIOS Setting	Description
Security Device Support	Enables / Disables BIOS support for security device. OS will not show security device. TCG EFI protocol and INTIA interface will not be available.
SHA256 PCR Bank	Enables / Disables SHA256 PCR Bank.
SHA384 PCR Bank	Enables / Disables SHA384 PCR Bank.
Pending operation	Schedule an operation for the security device. Note: Your computer will reboot during restart in order to change state of security device.
Platform / Storage/ Endorsement Hierarchy	Enables / Disables the hierarchy.
Physical Presence Spec Version	Selects to show the PPI Spec Version (1.2 or 1.3) that the OS supports. Note: Some HCK tests might not support 1.3.
PH Randomization	This option is intended for internal development and validation purposes only. Do not enable this setting on production systems.
Device Select	<ul style="list-style-type: none"> TPM 1.2 will restrict support to TPM 1.2 devices only. TPM 2.0 will restrict support to TPM 2.0 devices only. Auto will support both with the default being set to TPM 2.0 devices if not found, and TPM 1.2 device will be enumerated.

3.4.2 ACPI Settings



BIOS Setting	Description
Enable ACPI Auto Configuration	Enables or Disables BIOS ACPI Auto Configuration
Enable Hibernation	Enables / Disables the system ability to hibernate (OS/S4 Sleep State). This option may be not effective with some OS.

3.4.3 AMD CBS

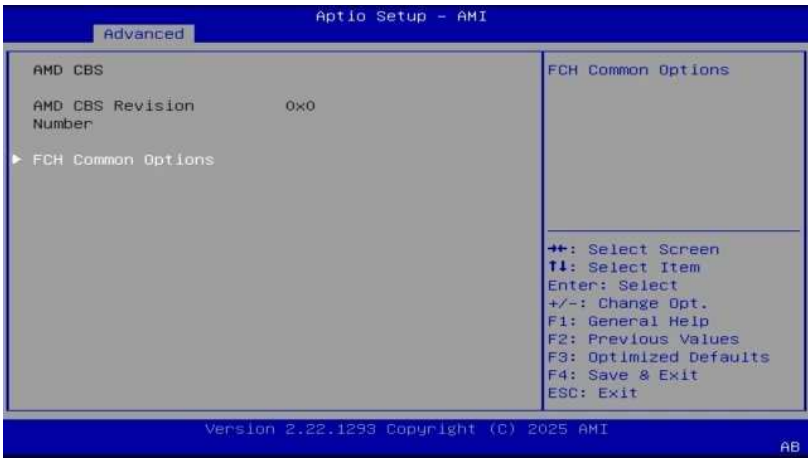

BIOS Setting	Description
FCH Common Options	FCH Common Options
AC Power Loss Options	AC Power Loss Options
Schedule Slot 1	Setup the hour/minute for system power on

3.4.4 NCT7904D HW Monitor

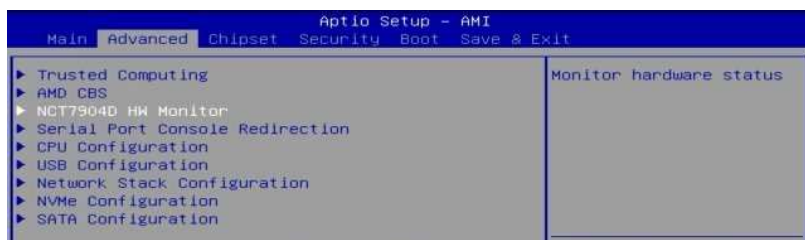

BIOS Setting	Description
Smart Fan Control	Enables / Disables the CPU Fan Control. Options: Disabled / 50 °C / 60 °C / 70 °C / 80 °C
Temperatures / Voltages	These fields are the parameters of the hardware monitoring function feature of the motherboard. The values are read-only values as monitored by the system and show the PC health status.

3.4.5 Serial Port Console Redirection

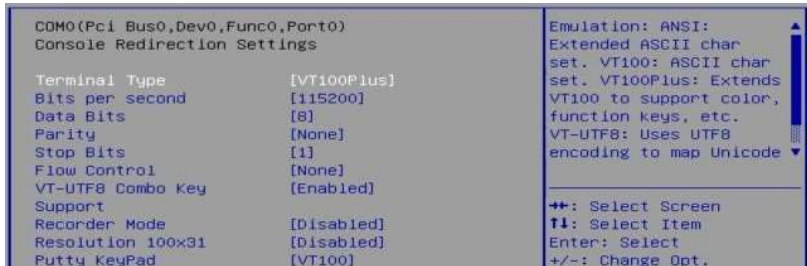

BIOS Setting	Description
Console Redirection	Console Redirection. Enable or Disable.
Terminal Type	Emulation: ANSI: Extended ASCII character set. VT100: ASCII character set. VT100Plus: Extends VT100 to support color, function keys, etc. VT-UTF8: uses UTF8 encoding to map Unicode characters onto 1 or more bytes.
Bits per second	Selects serial port transmission speed. The speed must be matched on the other side. Long or noisy lines may require lower speeds.
Data Bits	(AMI BIOS often leaves this description minimal or blank; this is normal.)

Parity	A parity bit can be sent with the data bits to detect some transmission errors. Even: parity bit is 0 if the number of 1's in the data bits is even. Odd: parity bit is 0 if the number of 1's in the data bits is odd. Mark: parity bit is always 1. Space: parity bit is always 0. Mark and Space parity do not allow for error detection. They can be used as an additional bit.
Stop Bits	Stop bits indicate the end of a serial data packet. (A start bit indicates the beginning.) The standard setting is 1 stop bit. Communication with slow devices may require more stop bits.
Flow Control	prevent data loss from buffer overflow when sending data, if the receiving buffers are full, a 'stop' signal can be sent to stop the data flow. Once the buffers are empty, a 'start' signal can be sent to re-start the flow. Hardware flow control uses two wires to send start/stop signals.
VT-UTF8 Combo Key Support	Enable VT-UTF8 Combination Key Support for ANSI/VT100 terminals.
Recorder Mode	With this mode enabled only text will be sent. This is to capture Terminal data.
Resolution 100x31	Enables or disables extended terminal resolution.
Putty KeyPad	Select FunctionKey and KeyPad on Putty.
Console Redirection Settings	The settings specify how the host computer and the remote computer exchange data.
Legacy Console Redirection Settings	Configure legacy console redirection behavior.
Redirection COM Port	Select a COM port to display redirection of Legacy OS and Legacy OPROM messages.
Resolution	On Legacy OS, the number of rows and columns supported for console redirection.
Redirect After POST	When Bootloader is selected, then Legacy Console Redirection is disabled before booting to legacy OS. When Always Enable is selected, then Legacy Console Redirection is enabled for legacy OS. Default setting for this option is set to Always Enable.
Console Redirection EMS	Console Redirection Enable or Disable

3.4.6 CPU Configuration

Aptio Setup - AMI	
Main Advanced Chipset Security Boot Save & Exit	
<ul style="list-style-type: none"> ▶ Trusted Computing ▶ AMD CBS ▶ NCT7904D HW Monitor ▶ Serial Port Console Redirection ▶ CPU Configuration ▶ USB Configuration 	CPU Configuration Parameters
Advanced Aptio Setup - AMI	
CPU Configuration SVM Mode [Enabled] ▶ Node 0 Information	View Memory Information related to Node 0
Advanced Aptio Setup - AMI	
CPU Configuration SVM Mode [Enabled] ▶ Node 0 Information	Enable/disable CPU Virtualization
Advanced Aptio Setup - AMI	
Node 0 Information AMD EPYC 8224P 24-Core Emb Processor 24 Cores 48 Threads Running @ 2568 MHz 900 mV Processor Family: 19h Processor Model: A0h-AFh Microcode Patch Level: AA00219 ----- Cache per Core ----- L1 Instruction Cache: 32 KB/8-way L1 Data Cache: 32 KB/8-way L2 Cache: 1024 KB/8-way L3 Cache per Socket: 64 MB/16-way	++: Select Screen ↑↓: Select Item Enter: Select +/-: Change Opt. F1: General Help F2: Previous Values F3: Optimized Defaults F4: Save & Exit ESC: Exit
Version 2.22.1293 Copyright (C) 2025 AMI	
AB	

BIOS Setting	Description
CPU Configuration	View Memory Information related to Node 0
SVM Mode	Enable/disable CPU virtualization
Node 0 Information	View detailed CPU and cache information for Node 0

3.4.7 USB Configuration

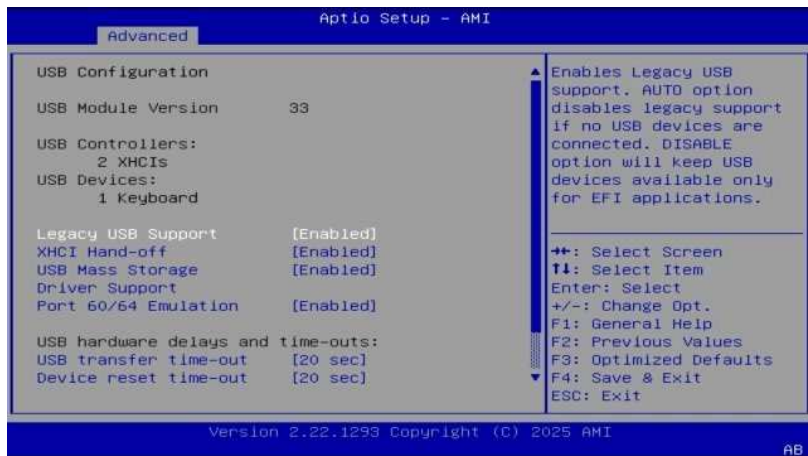

BIOS Setting	Description
Legacy USB Support	<ul style="list-style-type: none"> • Enabled enables Legacy USB support. • Auto disables legacy support if there is no USB device connected. • Disabled keeps USB devices available only for EFI applications.
XHCI Hand-off	This is a workaround for OSeS without XHCI hand-off support. The XHCI ownership change should be claimed by XHCI driver.
USB Mass Storage Driver Support	Enables / Disables the support for USB mass storage driver.
Port 60/64 EmulationDriver Support	Enables I/O port 60h/64h emulation for the complete USB keyboard legacy support for non-USB aware OSeS.
USB Transfer time-out	The time-out value (1 / 5 10 / 20 secs) for Control, Bulk, and Interrupt transfers.
Device reset time-out	Gives seconds (10 / 20 / 30 / 40 secs) to delay execution of Start Unit command to USB mass storage device.
Device power-up delay	The maximum time the device will take before it properly reports itself to the Host Controller. Auto uses default value for a Root port it is 100ms. But for a Hub port, the delay is taken from Hub descriptor.

3.4.8 Network Stack Configuration

Aptio Setup - AMI		
Advanced		
Network Stack	[Disabled]	Enable/Disable UEFI Network Stack

Aptio Setup - AMI		
Advanced		
Network Stack	[Enabled]	Enable/Disable UEFI Network Stack
IPv4 PXE Support	[Disabled]	
IPv4 HTTP Support	[Disabled]	
IPv6 PXE Support	[Disabled]	
IPv6 HTTP Support	[Disabled]	
PXE boot wait time	0	
Media detect count	1	

BIOS Setting	Description
Network Stack	Enables / Disables UEFI Network Stack.
IPv4 PXE Support	Enables / Disables IPv4 PXE Boot Support. If disabled, IPv4 PXE boot option will not be created.
IPv4 HTTP Support	Enables / Disables IPv4 HTTP Boot Support. If disabled, IPv4 HTTP boot option will not be created.
IPv6 PXE Support	Enables / Disables IPv6 PXE Boot Support. If disabled, Ipv6 PXE boot option will not be created.
IPv6 HTTP Support	Enables / Disables IPv6 HTTP Boot Support. If disabled, Ipv6 HTTP boot option will not be created.
PXE boot wait time	Assigns a period of time to press ESC key to abort the PXE boot.
Media detect count	Assigns a number of times to check the presence of media.

3.4.9 SATA Configuration

Aptio Setup - AMI

Advanced

<p>SATA Configuration</p> <p>SATA Controller (S:00 B:03 D:00 F:01)</p> <p>Port 0 Not Present</p> <p>Port 1 Not Present</p> <p>Port 2 Not Present</p> <p>Port 3 Not Present</p>	<p>⇐⇐: Select Screen</p> <p>⇐1: Select Item</p> <p>Enter: Select</p> <p>+/-: Change Opt.</p> <p>F1: General Help</p> <p>F2: Previous Values</p> <p>F3: Optimized Defaults</p> <p>F4: Save & Exit</p> <p>ESC: Exit</p>
--	---

Version 2.22.1293 Copyright (C) 2025 AMI

AB

Aptio Setup - AMI

Main **Advanced** Chipset Security Boot Save & Exit

<ul style="list-style-type: none"> ▶ Trusted Computing ▶ AMD CBS ▶ NCT7904D HW Monitor ▶ Serial Port Console Redirection ▶ CPU Configuration ▶ USB Configuration ▶ Network Stack Configuration ▶ NVMe Configuration ▶ SATA Configuration ▶ Intel(R) Ethernet Network Adapter X710-TL - 00:03:2D:62:14:6E ▶ Intel(R) Ethernet Network Adapter X710-TL - 00:03:2D:62:14:6F 	<p>SATA Devices Information.</p> <p>⇐⇐: Select Screen</p> <p>⇐1: Select Item</p> <p>Enter: Select</p> <p>+/-: Change Opt.</p> <p>F1: General Help</p> <p>F2: Previous Values</p> <p>F3: Optimized Defaults</p> <p>F4: Save & Exit</p> <p>ESC: Exit</p>
--	--

Version 2.22.1293 Copyright (C) 2025 AMI

AB

3.4.10 Intel(R) Ethernet Network Adapter

Aptio Setup - AMI

Main | **Advanced** | Chipset | Security | Boot | Save & Exit

<ul style="list-style-type: none"> ▶ Trusted Computing ▶ AMD CBS ▶ NCT7904D HW Monitor ▶ Serial Port Console Redirection ▶ CPU Configuration ▶ USB Configuration ▶ Network Stack Configuration ▶ NVME Configuration ▶ SATA Configuration 	Configure 10 Gigabit Ethernet device parameters.
<ul style="list-style-type: none"> ▶ Intel(R) Ethernet Network Adapter X710-TL - 00:03:2D:62:14:6E ▶ Intel(R) Ethernet Network Adapter X710-TL - 00:03:2D:62:14:6F 	++: Select Screen ↑↓: Select Item Enter: Select +/-: Change Opt.

Aptio Setup - AMI

Advanced

<ul style="list-style-type: none"> ▶ Firmware Image Properties ▶ NIC Configuration 	View device firmware version information.
Blink LEDs 0	
UEFI Driver Intel(R) 40GbE 5.0.20 Adapter PBA 000000-000 Device Name Intel(R) Ethernet Network Adapter X710-TL	
Chip Type Intel X710 PCI Device ID 15FF PCI Address 01:00:00	++: Select Screen ↑↓: Select Item Enter: Select +/-: Change Opt. F1: General Help F2: Previous Values F3: Optimized Defaults F4: Save & Exit ESC: Exit
Link Status [Disconnected]	
MAC Address 00:03:2D:62:14:6E Virtual MAC Address 00:00:00:00:00:00	

Version 2.22.1293 Copyright (C) 2025 AMI AB

Aptio Setup - AMI

Advanced

Option ROM version 1.3800.0 Unique NVM/EEPROM ID 0x8000FB80 NVM Version 9.54	
---	--

Aptio Setup - AMI

Advanced

<ul style="list-style-type: none"> ▶ Firmware Image Properties ▶ NIC Configuration 	Click to configure the network device port.
--	---

Aptio Setup - AMI

Advanced

Link Speed [Auto Negotiated] Wake On LAN [N/A] Legacy Virtual LAN ID 0 LLDP Agent [Enabled]	Specifies the VLAN ID used for PXE VLAN Mode. The valid VLAN ID range is from 0 to 4094. PXE VLAN is disabled if the VLAN ID is set to 0. Note that this setting is only applicable when
--	--

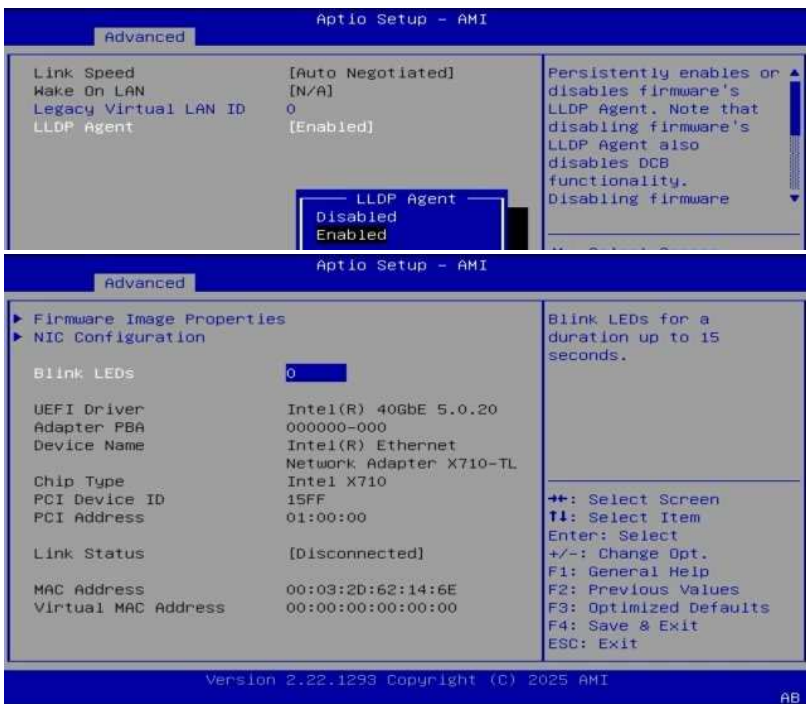

BIOS Setting	Description
Intel(R) Ethernet Network Adapter X710-TL - 00:03:2D:62:14:6E	Configure 10 Gigabit Ethernet device parameters.
Link Speed	Specifies the link speed. Auto Negotiated allows the adapter and link partner to determine the optimal speed automatically.
Firmware Image Properties	View device firmware version information.
NIC Configuration	Click to configure the network device port.
Legacy Virtual LAN ID	Specifies the VLAN ID used for PXE VLAN Mode. The valid VLAN ID range is from 0 to 4094. PXE VLAN is disabled if the VLAN ID is set to 0. Note that this setting is only applicable when PXE is enabled.
LLDP Agent	Persistently enables or disables firmware's LLDP Agent. Note that disabling firmware's LLDP Agent also disables DCB functionality.

Blink LEDs	Blink LEDs for a duration up to 15 seconds.
Intel(R) Ethernet Network Adapter X710-TL - 00:03:2D:62:14:6F	Identifies the Intel® Ethernet Network Adapter X710-TL and displays its MAC address.
Link Speed	Specifies the link speed. Auto Negotiated allows the adapter and link partner to determine the optimal speed automatically.
Firmware Image Properties	View device firmware version information.
NIC Configuration	Click to configure the network device port.
Legacy Virtual LAN ID	LLDP Agent also disables DCB functionality. Disabling firmware Agent allows LLDP packets from the switch to pass unobstructed to the OS. Some OS layer LLDP agents and software defined network layer LLDP agents need these packets to function.
LLDP Agent	Persistently enables or disables firmware's LLDP Agent. Disabling the LLDP Agent also disables DCB functionality.
Blink LEDs	Blink LEDs for a duration up to 15 seconds.

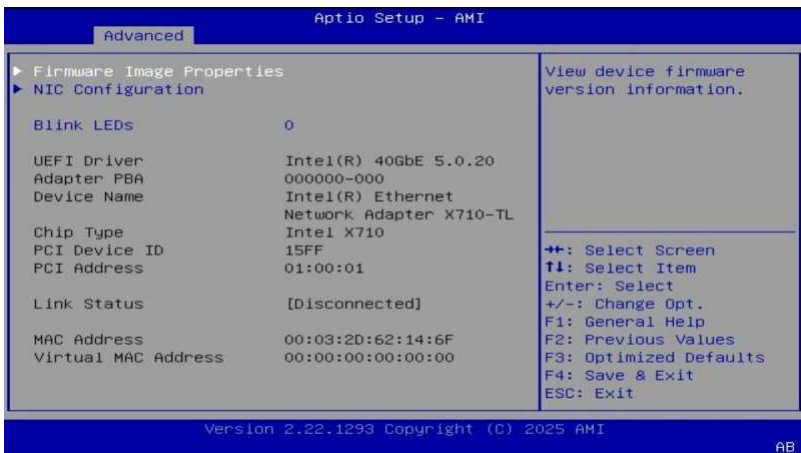

Aptio Setup - AMI	
Main Advanced Chipset Security Boot Save & Exit	
<ul style="list-style-type: none"> ▶ Trusted Computing ▶ AMD CBS ▶ NCT7904D HW Monitor ▶ Serial Port Console Redirection ▶ CPU Configuration ▶ USB Configuration ▶ Network Stack Configuration ▶ NVMe Configuration ▶ SATA Configuration 	Configure 10 Gigabit Ethernet device parameters.
<ul style="list-style-type: none"> ▶ Intel(R) Ethernet Network Adapter X710-TL - 00:03:2D:62:14:6E ▶ Intel(R) Ethernet Network Adapter X710-TL - 00:03:2D:62:14:6F 	++: Select Screen ↑↓: Select Item Enter: Select +/-: Change Opt. F1: General Help F2: Previous Values F3: Optimized Defaults F4: Save & Exit ESC: Exit

Version 2.22.1293 Copyright (C) 2025 AMI

AB

Aptio Setup - AMI	
Advanced	
Option ROM version	1.3800.0
Unique NVM/EEPROM ID	0x8000FB80
NVM Version	9.54

Aptio Setup - AMI	
Advanced	
<ul style="list-style-type: none"> ▶ Firmware Image Properties ▶ NIC Configuration 	Click to configure the network device port.

Aptio Setup - AMI		
Advanced		
Link Speed	[Auto Negotiated]	Specifies the VLAN ID used for PXE VLAN Mode. The valid VLAN ID range is from 0 to 4094. PXE VLAN is disabled if the
Wake On LAN	[N/A]	
Legacy Virtual LAN ID	0	
LLDP Agent	[Enabled]	

Aptio Setup - AMI		
Advanced		
Link Speed	[Auto Negotiated]	LLDP Agent. Note that disabling firmware's LLDP Agent also disables DCB
Wake On LAN	[N/A]	
Legacy Virtual LAN ID	0	
LLDP Agent	[Enabled]	

Aptio Setup - AMI	
Advanced	
<ul style="list-style-type: none"> ▶ Firmware Image Properties ▶ NIC Configuration 	Blink LEDs for a duration up to 15 seconds.
Blink LEDs	0
UEFI Driver Adapter PBA Device Name	Intel(R) 40GbE 5.0.20 000000-000 Intel(R) Ethernet Network Adapter X710-TL
Chip Type	Intel X710
PCI Device ID	15FF
PCI Address	01:00:01
Link Status	[Disconnected]
MAC Address	00:03:2D:62:14:6F
Virtual MAC Address	00:00:00:00:00:00
	++: Select Screen ↑↓: Select Item Enter: Select +/-: Change Opt. F1: General Help F2: Previous Values F3: Optimized Defaults

3.5 Chipset Settings

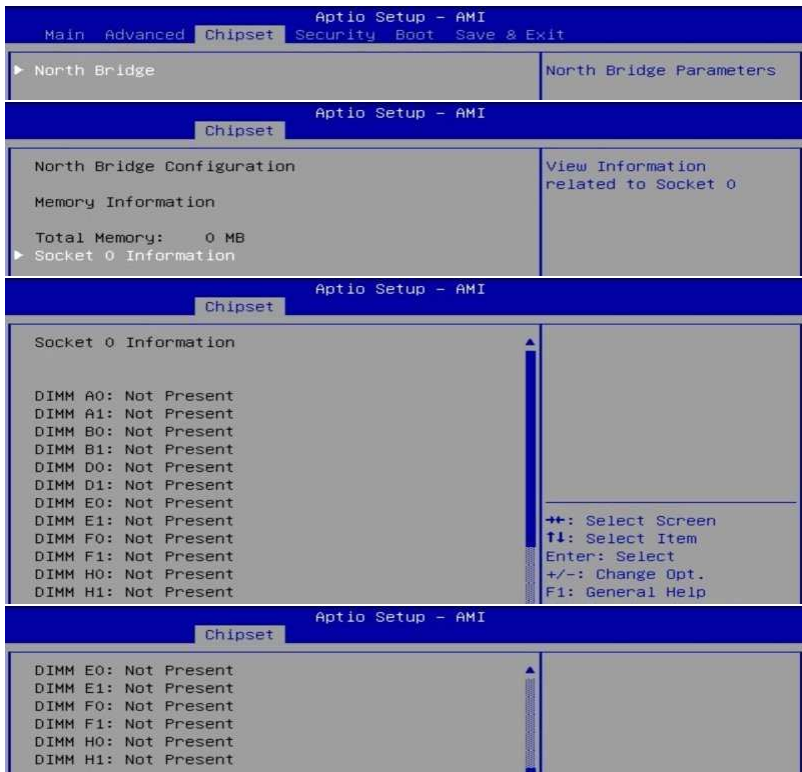

3.6 Security Settings

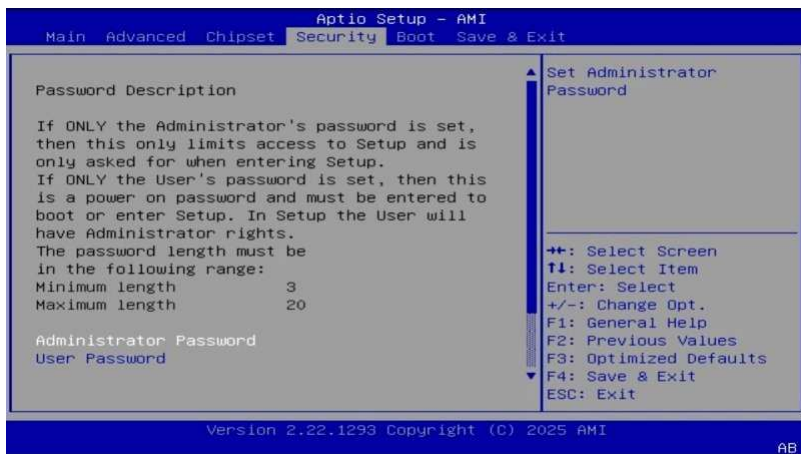

BIOS Setting	Description
Administrator Password	Set administrator password.
User Password	Set user password.
Secure Boot	Configures Secure Boot.

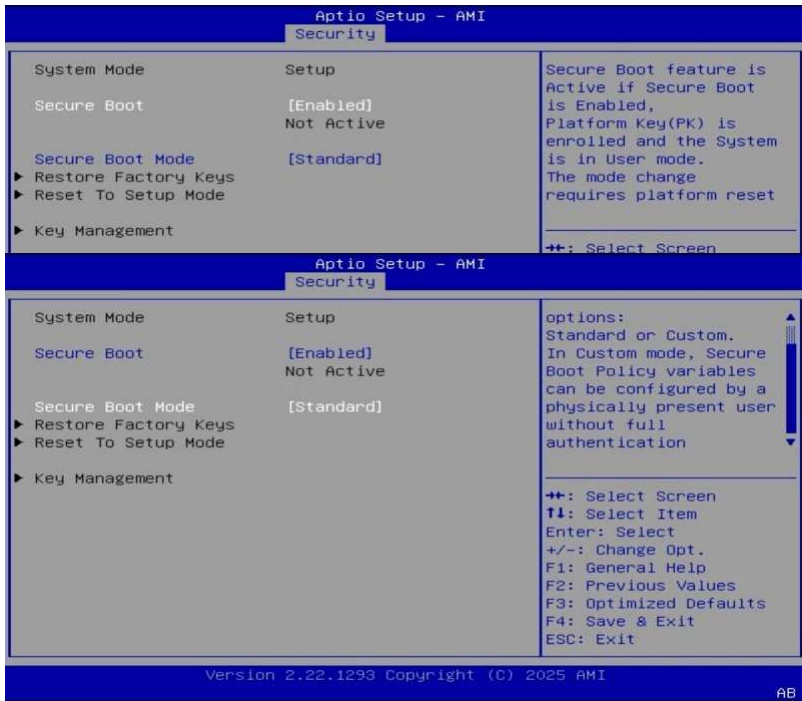

BIOS Setting	Description
Secure Boot	Secure Boot feature is Active if Secure Boot is enabled. Platform Key (PK) Is enrolled and the system is in User mode. The mode change requires platform reset.
Secure Boot Mode	Secure Boot mode options: Standard or Custom. In Custom mode, Secure Boot policy variables can be configured by a physically present user without full authentication.
Restore Factory Keys	Restores the default Secure Boot keys provided by the system manufacturer.
Reset to Setup Mode	Clears all Secure Boot keys and places the system into Setup Mode.
Key Management	Allows viewing, adding, or deleting Secure Boot keys and certificates.

3.7 Boot Settings

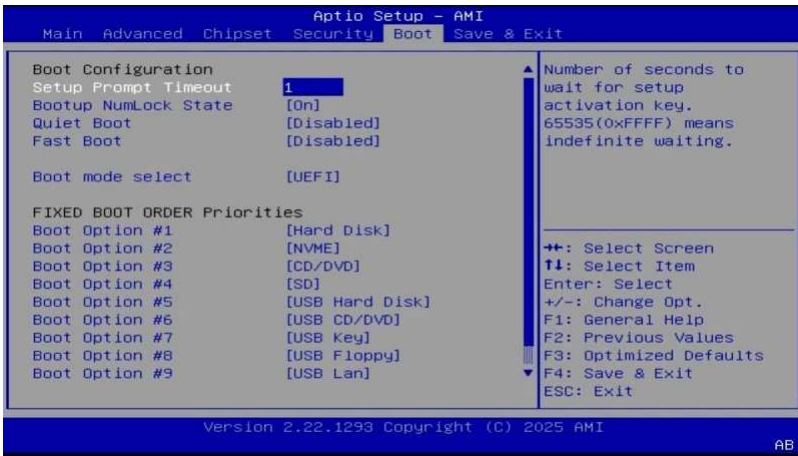

BIOS Setting	Description
Setup Prompt Timeout	Number of seconds to wait for setup activation key. 65535(0xFFFF) means indefinite waiting.
Bootup NumLock State	Selects the keyboard NumLock state.
Quiet Boot	Enables / Disables Quiet Boot option.
Fast Boot	Enables / Disables boot with initialization of a minimal set of devices required to launch active boot option. Has no effect for BBS boot options.
Boot mode select	Selects a Boot mode, Legacy / UEFI.
Boot Option Priorities	Sets the system boot order.

3.8 Save & Exit Settings



BIOS Setting	Description
Save Changes and Exit	Exits system setup after saving the changes.
Discard Changes and Exit	Exits system setup without saving any changes.
Save Changes and Reset	Resets the system after saving the changes.
Discard Changes and Reset	Resets system setup without saving any changes.
Save Changes	Saves changes done so far to any of the setup options.
Discard Changes	Discards changes done so far to any of the setup options.
Restore Defaults	Restores / Loads defaults values for all the setup options.
Save as User Defaults	Saves the changes done so far as User Defaults.
Restore User Defaults	Restores the user defaults to all the setup options.
Launch EFI Shell from filesystem device	Launches the EFI Shell from a filesystem device.

