

**IPPC1505-RE  
IPPC1705-RE  
IPPC1905-RE**

**Expandable Panel PC**

**User's Manual**

Version 1.0  
(Mar. 2019)



## **Copyright**

© 2019 IBASE Technology, Inc. All rights reserved.

No part of this publication may be reproduced, copied, stored in a retrieval system, translated into any language or transmitted in any form or by any means, electronic, mechanical, photocopying, or otherwise, without the prior written consent of IBASE Technology, Inc. (hereinafter referred to as "IBASE").

## **Disclaimer**

IBASE reserves the right to make changes and improvements to the products described in this document without prior notice. Every effort has been made to ensure the information in the document is correct; however, IBASE does not guarantee this document is error-free. IBASE assumes no liability for incidental or consequential damages arising from misapplication or inability to use the product or the information contained herein, nor for any infringements of rights of third parties, which may result from its use.

## **Trademarks**

All the trademarks, registrations and brands mentioned herein are used for identification purposes only and may be trademarks and/or registered trademarks of their respective owners.

## Compliance



This product may cause radio interference in which case users may be required to take adequate measures.



This product has been tested and found to comply with the limits for a Class B device, pursuant to Part 15 of the FCC Rules. These limits are designed to provide reasonable protection against harmful interference in a residential installation. This equipment generates, uses and can radiate radio frequency energy and, if not installed and used in accordance with manufacturer's instructions, may cause harmful interference to radio communications.

Operation is subject to the following two conditions:

- This product may not cause harmful interference
- This product must accept any interference received including interference that may cause undesired operation.

However, there is no guarantee that interference will not occur in a particular installation. If this equipment causes harmful interference to radio or television reception which can be determined by turning the equipment off and on, you may correct the interference by one or more of the following measures:

- Reorient or relocate the receiving antenna.
- Increase the separation between the equipment and the receiver.
- Connect the equipment to an outlet on a circuit different from that to which the receiver is connected.
- Consult the distributor or an experienced radio/TV technician for help.

## WEEE



This product must not be disposed of as normal household waste, in accordance with the EU directive of for waste electrical and electronic equipment (WEEE - 2012/19/EU). Instead, it should be disposed of by returning it to a municipal recycling collection point. Check local regulations for disposal of electronic products.

## Green iBASE



This product complies with the current RoHS restrictions that prohibit the use of the following substances in concentrations exceeding 0.1% by weight (1000 ppm) except for cadmium, limited to 0.01% by weight (100 ppm).

- Lead (Pb)
- Mercury (Hg)
- Cadmium (Cd)
- Hexavalent chromium (Cr6+)
- Polybrominated biphenyls (PBB)
- Polybrominated diphenyl ether (PBDE)

## Important Safety Information

Carefully read the precautions before using the device.

### Environmental conditions:

- Put the device horizontally on a stable and solid surface during installation in case the device may fall, causing serious damage.
- Leave plenty of space around the device for ventilation.
- Use this product in environments with ambient temperatures between 0°C and 40°C.
- DO NOT LEAVE THIS DEVICE IN AN ENVIRONMENT WHERE THE STORAGE TEMPERATURE MAY BE BELOW -20° C OR ABOVE 60° C. To prevent from damages, the device must be used in a controlled environment.
- Keep the device away from humidity to avoid fog or condensation from accumulating on the inner surface of the panel.

### Care for your iBASE products:

- Before cleaning the device, turn it off and unplug all cables in case a small amount of electrical current may still flow.
- Use neutral cleaning agents or diluted alcohol to clean the device chassis with a cloth. Then wipe the chassis with a dry cloth.
- Use a computer vacuum cleaner to remove dust to prevent the air vent or slots from getting clogged.



## WARNING

### Attention during use:

- Do not use this product near water.
- Do not spill water or any other liquids on your device.
- Do not place heavy objects on the top of the device.
- Operate this device from the type of power indicated on the marking label. If you are not sure of the type of power available, consult your distributor or local power company.
- Ensure to use the correct power supply voltage.
- Do not walk on the power cord or allow anything to rest on it.
- If you use an extension cord, make sure that the total ampere rating of the product plugged into the extension cord does not exceed its limits.

### Avoid Disassembly

Disassembly, modification, or any attempt at repair could generate hazards and cause damage to the device, even bodily injury or property damage, and will void any warranty on the product.



## CAUTION

Replace only with the same or equivalent type recommended by the manufacturer. Dispose of used batteries according to the manufacturer's instructions.

## Warranty Policy

- **IBASE standard products:**  
24-month (2-year) warranty from the date of shipment. If the date of shipment cannot be ascertained, the product serial numbers can be used to determine the approximate shipping date.
- **3<sup>rd</sup>-party parts:**  
12-month (1-year) warranty from delivery for the 3<sup>rd</sup>-party parts that are not manufactured by IBASE, such as CPU, CPU cooler, memory, storage devices, power adapter, panel and touch screen.
- \* Products, however, that fail due to misuse, accident, improper installation or unauthorized repair shall be treated as out of warranty and customers shall be billed for repair and shipping charges.

## Technical Support & Services

1. Visit the IBASE website at [www.ibase.com.tw](http://www.ibase.com.tw) to find the latest information about the product.
2. If you need any assistance from your distributor or sales representative concerning problems that you may have encountered, please prepare the following information:
  - Product model name
  - Product serial number
  - Detailed description of the problem
  - Error messages in text or in screenshots if there is any
  - The arrangement of the peripherals
  - Software used (such as OS and application software, including the version numbers)
3. For repair service, please download the RMA form from <http://www.ibase.com.tw/english/Supports/RMAService/>.  
Fill out the form and contact your distributor or sales representative.

# Table of Contents

---

Compliance.....	iii
Important Safety Information .....	iv
<b>WARNING</b> .....	v
<b>CAUTION</b> .....	v
Warranty Policy.....	v
Technical Support & Services .....	vi
<b>Chapter 1 General Information.....</b>	<b>1</b>
1.1 Introduction .....	2
1.2 Features.....	2
1.3 Packing List .....	3
1.4 Specifications.....	4
1.5 Overview.....	6
1.6 Dimensions .....	8
<b>Chapter 2 Hardware Configuration .....</b>	<b>11</b>
2.1 Installations.....	12
2.1.1 Rear Cover Disassembly .....	12
2.1.2 Memory Replacement.....	13
2.1.3 SSD Replacement .....	13
2.1.4 Mini-PCIe Installation.....	14
2.1.5 VESA Mounting Installation .....	14
2.2 Pin out for COM1 & COM2.....	15
2.3 Setting the Jumpers .....	16
2.3.1 How to Set the Jumpers .....	16
2.4 Jumper & Connector Locations .....	17
2.5 Jumpers Quick Reference.....	18
2.5.1 LVDS Power Selection (J16).....	18
2.5.2 PCIe (x16) Bifurcation Selection (J10 & J11).....	19
2.5.3 Clearing ME Register (J21) .....	20
2.5.4 Clearing CMOS Data (J22) .....	21
2.6 Connectors Quick Reference .....	22
2.6.1 COM1 & COM2 RS-232/422/485 Ports (CN1).....	23
2.6.2 COM3 ~ COM6 RS-232 Ports (J1, J2, J3, J4).....	24

2.6.3	20-pin ATX Power Connector (J5).....	25
2.6.4	Digital I/O Connector (J6).....	26
2.6.5	4-pin ATX 12V Power Connector (J7) .....	26
2.6.6	Battery Connector (J24).....	27
2.6.7	Front Panel Audio Connector (J23).....	27
2.6.8	Front Panel Settings Connector (J25) .....	28
2.6.9	LCD Backlight Connector (JP2).....	29
2.6.10	LVDS Connector (JP3, JP4).....	29
2.6.11	USB 2.0 Connector (JP6, JP8).....	30
2.6.12	CPU Fan Power Connector (CPU_FAN1).....	30
2.6.13	System Fan Power Connector (SYS_FAN1, SYS_FAN2).....	31
<b>Chapter 3 Driver Installation .....</b>		<b>32</b>
3.1	Introduction .....	33
3.2	Intel® Chipset Software Installation Utility.....	33
3.3	HD Graphics Driver Installation .....	34
3.4	HD Audio Driver Installation .....	35
3.5	LAN Driver Installation .....	36
3.6	Intel® Management Engine Driver Installation .....	38
<b>Chapter 4 BIOS Setup.....</b>		<b>40</b>
4.1	Introduction .....	41
4.2	BIOS Setup.....	41
4.3	Main Settings .....	42
4.4	Advanced Settings .....	43
4.4.1	CPU Configuration.....	44
4.4.2	PCH-FW Configuration.....	45
4.4.3	Trusted Computing .....	46
4.4.4	ACPI Settings .....	47
4.4.5	LVDS (eDP/DP) Configuration.....	48
4.4.6	iSmart Controller.....	49
4.4.7	Fintek Super IO Configuration .....	50
4.4.8	Fintek Super I/O Hardware Monitor .....	57
4.4.9	CSM Configuration .....	58
4.4.10	NVMe Configuration .....	59
4.4.11	USB Configuration.....	60
4.5	Chipset Settings.....	61
4.5.1	System Agent (SA) Configuration .....	61
4.5.2	PCH-IO Configuration.....	63
4.6	Security Settings .....	65
4.7	Boot Settings.....	66

4.8	Save & Exit Settings.....	67
<b>Appendix</b>	.....	<b>68</b>
A.	I/O Port Address Map.....	69
B.	Interrupt Request Lines (IRQ) .....	72
C.	Watchdog Timer Configuration.....	74

# Chapter 1

## General Information

The information provided in this chapter includes:

- Features
- Packing List
- Specifications
- Overview
- Dimensions

## 1.1 Introduction

IPPC1505-RE, IPPC1705-RE and IPPC1905-RE are 15", 17" and 19" expandable touch panel PC, ideal for industrial automation, factory automation applications. The three products are powered by Intel® Core™ i7/i5/i3 based processor, and come with the level of IP65 ingress protection for the front bezel to provide good quality of water-tight.



## 1.2 Features

- Resistive touch screen and fanless design
- Cost effective model & Low power consumption
- IP65-rated front bezel
- Front side accessible USB port and rich I/O interface
- Two PCIe (x8) expansion slots

### 1.3 Packing List

Your product package should include the items listed below. If any of the items below is missing, contact the distributor or the dealer from whom you have purchased the product.

#### **IPPC1505-RE:**

- IPPC1505-RE x 1
- Power Adapter x 1
- Power Cord x 1
- Panel Mounting Triangle Bracket x 8
- Short Screws x 16  
(M3\*6, for mounting the triangle brackets onto the device)
- Long Screws x 8  
(M4\*35, for mounting the device on wall)
- Rubber Spacer (D2.7mm) x 1
- Silicon Rubber x 1

#### **IPPC1705-RE:**

- IPPC1705-RE x 1
- Power Adapter x 1
- Power Cord x 1
- Panel Mounting Triangle Bracket x 8
- Short Screws x 16  
(M3\*6, for mounting the triangle brackets onto the device)
- Long Screws x 8  
(M4\*35, for mounting the device on wall)
- Rubber Spacer (D2.7mm) x 1
- Silicon Rubber x 1

#### **IPPC1905-RE:**

- IPPC-1905-RE x 1
- Power Adapter x 1
- Power Cord x 1
- Panel Mounting Triangle Bracket x 10
- Short Screws x 20  
(M3\*6, for mounting the triangle brackets onto the device)
- Long Screws x 10  
(M4\*35, for mounting the device on wall)
- Rubber Spacer (D2.7mm) x 1
- Silicon Rubber x 1

## 1.4 Specifications

Product Name	IPPC1505-RE	IPPC1705-RE	IPPC1905-RE
<b>Display &amp; Touch Screen</b>			
Display Size	15" TFT-LCD	17" TFT-LCD	19" TFT-LCD
Max. Resolution	1024 x 768	1280 x 1024	1280 x 1024
Luminance (cd/m <sup>2</sup> )	420	350	350
Contrast	600:1	800:1	1000:1
Max. Color	16.2M	16.7M	16.7M
View Angle (H°/V°)	160/160	160/140	170/160
Backlight Lifetime (hrs)	50,000		
Touch Type	Resistive		
Touch Interface	USB		
Light Transmission (%)	79		
Point of Touch	1		
<b>I/O Interface</b>			
USB 3.0	6		
USB 2.0	1 at front bezel		
RS-232/422/485 (Selectable under BIOS)	1		
RS-232	1		
LAN	2 x GbE		
Additional Graphics	<ul style="list-style-type: none"> <li>• 1 x DVI-D</li> <li>• 1 x DisplayPort</li> <li>• 1 x HDMI (1.4)</li> </ul>		
Audio	Line-In, Line-Out, Mic-In jacks (3.5 mm)		
Digital I/O	Optional 4-In/4-Out GPIO		
Power Connector	3-Pin Terminal Block		
Power Button	Rocker Switch		
<b>Mechanical</b>			
Dimensions (mm)	410 x 335 x 126.3	442 x 377 x 132.8	480 x 415 x 127.6
Net Weight (kg)	9.3	10	10.5

System	
Processor	Intel® Core™ <ul style="list-style-type: none"> <li>• i7-6822EQ</li> <li>• i5-6442EQ</li> <li>• i3-6102E</li> </ul>
Memory	2 x DDR4 SO-DIMM, up to 32 GB, default 4 GB
Thermal Design	Fanless
Membrane Control	N/A
Built-in Speaker / Mic	N/A
Motherboard	MI992
Operating System	Windows 10, 7 (32/64-bit) & Linux Kernel 3+
Expansion	
Internal Expansion Bus	<ul style="list-style-type: none"> <li>• 1 x M.2 M2280</li> <li>• 1 x Mini-PCIe full/half size with mSATA</li> </ul>
Expansion Slot	2 x PCIe (x8) slots
Wireless	Optional
Storage Space	
SSD	2 x 2.5" SATA3 SSD (One 64G SSD is included by default)
Removable	N/A
Power	
Power Input Range	12V / 24V DC Input
Construction	
Chassis Material	Aluminum & SGCC
Color (Front /Back)	Black / Black
IP Rating	IP65 for front panel
Mounting	VESA 75 x 75 mm / 100 x 100 mm
Environment	
Operating Temperature	<ul style="list-style-type: none"> <li>• <b>With SSD:</b> 0 ~ 50°C (32 ~ 122°F)</li> <li>• <b>With HDD:</b> 0 ~ 40°C (32 ~ 104°F)</li> </ul>
Storage Temperature	-20 ~ 70 °C (-4 ~ 158 °F)
Storage Humidity	10 ~ 90% (non-condensing) at 40 °C
Certification	CE, FCC Class B, LVD

All specifications are subject to change without prior notice.

## 1.5 Overview

### Front View



(with a USB 2.0 Port)

### Oblique View



**I/O View**

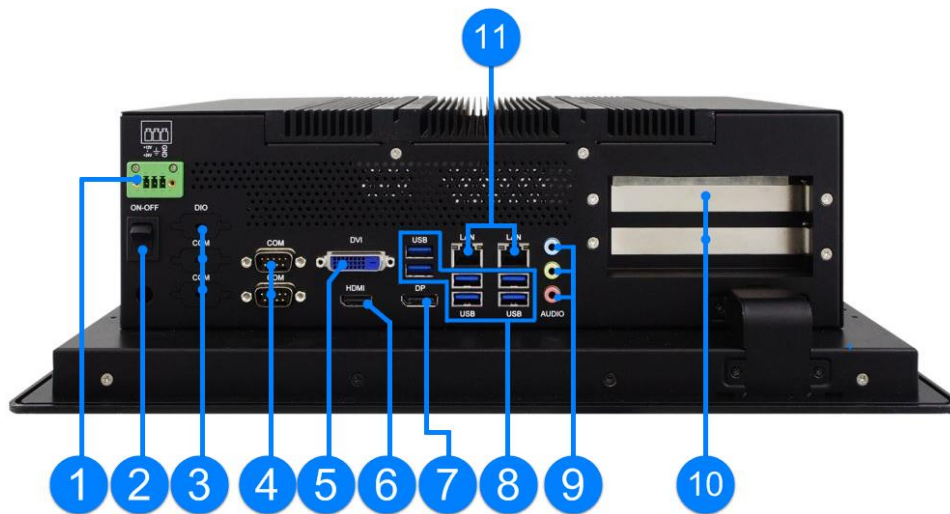

No.	Name	No.	Name
1	DC-In Power Connector (3-pin terminal block, 12 ~ 24V)	7	DisplayPort
2	Power Switch	8	USB 3.0 Ports
3	Reserved Shutoffs for Digital I/O and COM3/4 Ports	9	Audio Jacks (From top to bottom: Line-In, Line-Out, Mic-In)
4	COM1 RS-232/422/485 & COM2 RS-232 Ports	10	PCIe (x8) Expansion Card Slots
5	HDMI Port	11	GbE LAN Port
6	DVI-D Port		

## 1.6 Dimensions

Unit: mm

### IPPC1505-RE:

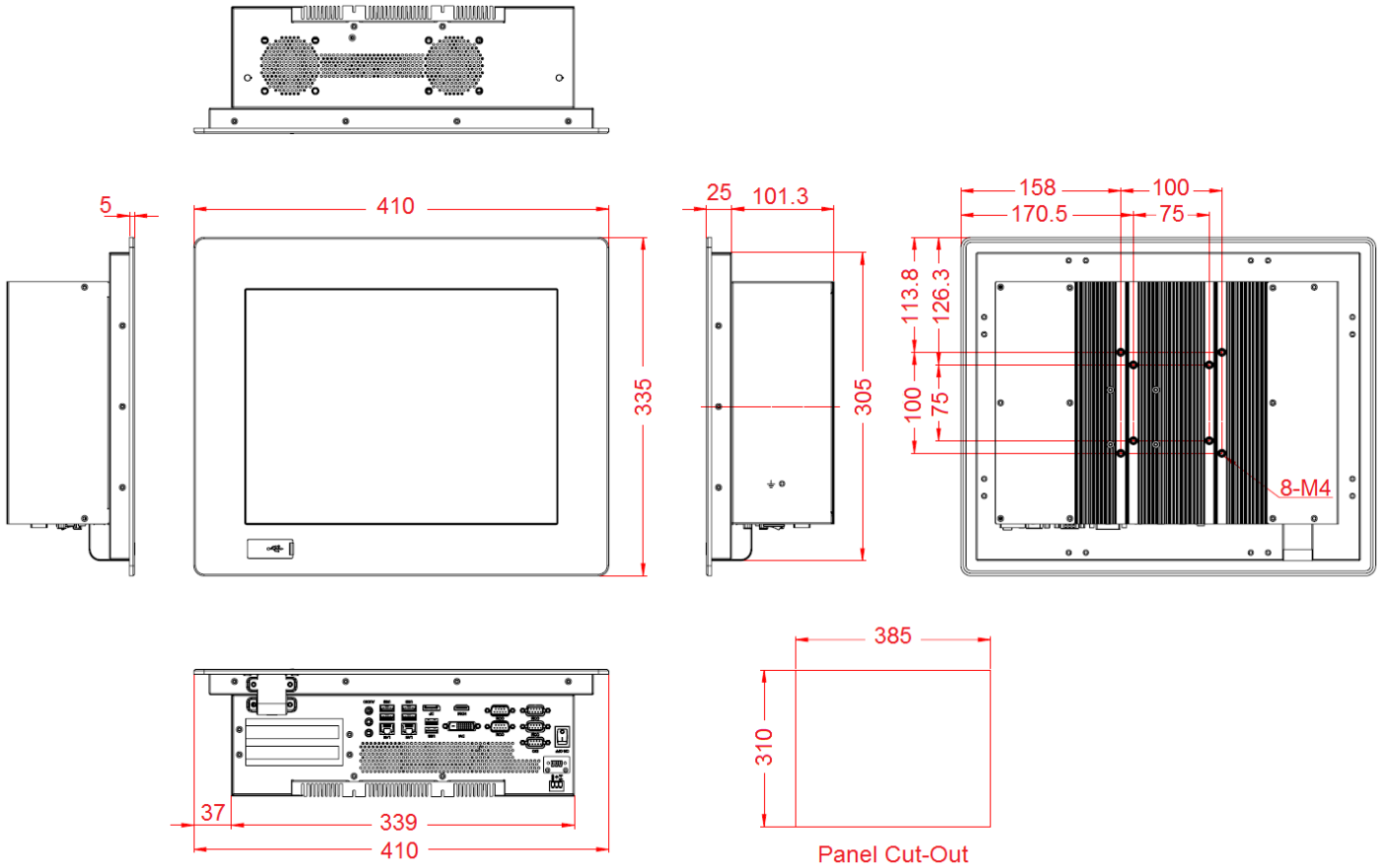

Unit: mm

IPPC1705-RE:

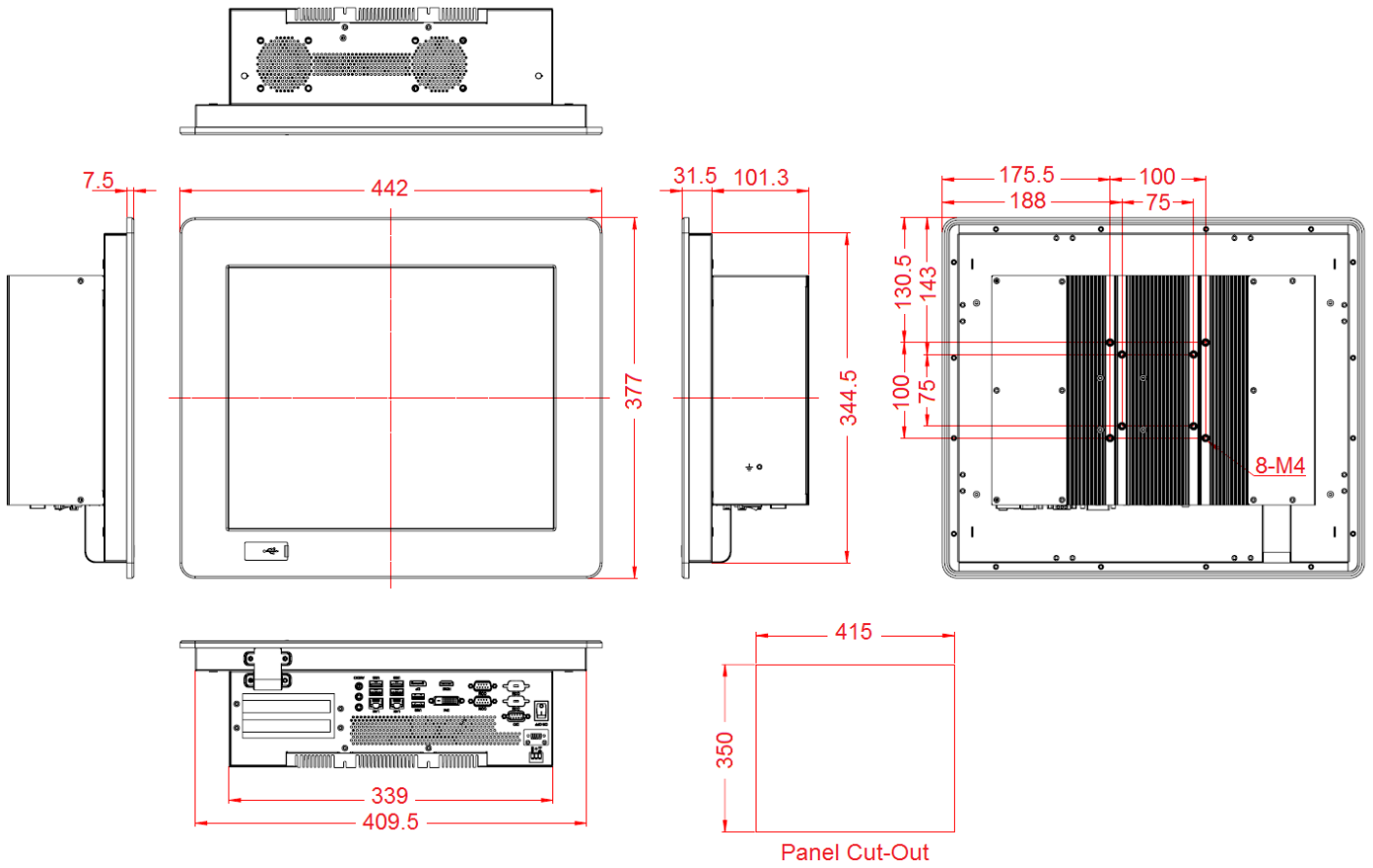

IPPC1905-RE:

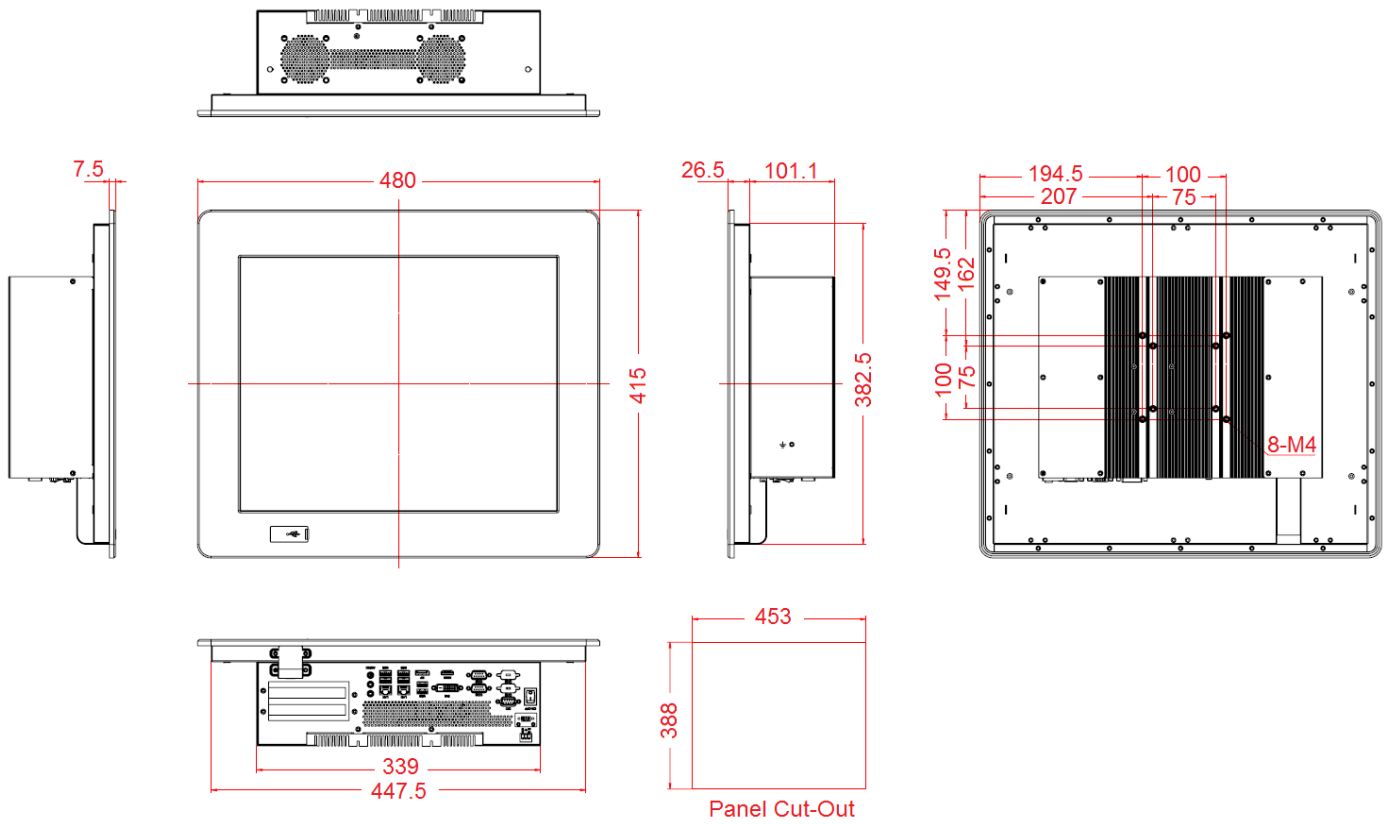

## Chapter 2

# Hardware Configuration

The information provided in this chapter includes:

- Memory installation and membrane keypad extension
- Information and locations of connectors

## 2.1 Installations

---

**Avoid device disassembly:** Disassembly, modification, or any attempt at repair could generate hazards and cause damage to the device, injury, or property damage, and will void any warranty. If you need to make any changes to the device, be sure to unplug the power cord of the device and have qualified engineers or technicians do the disassembly or installation.

---

### 2.1.1 Rear Cover Disassembly

In case you need to remove the rear cover to install a memory module, a mini-PCIe card or any expansion card, unscrew the 17 screws as shown below to remove the rear cover.

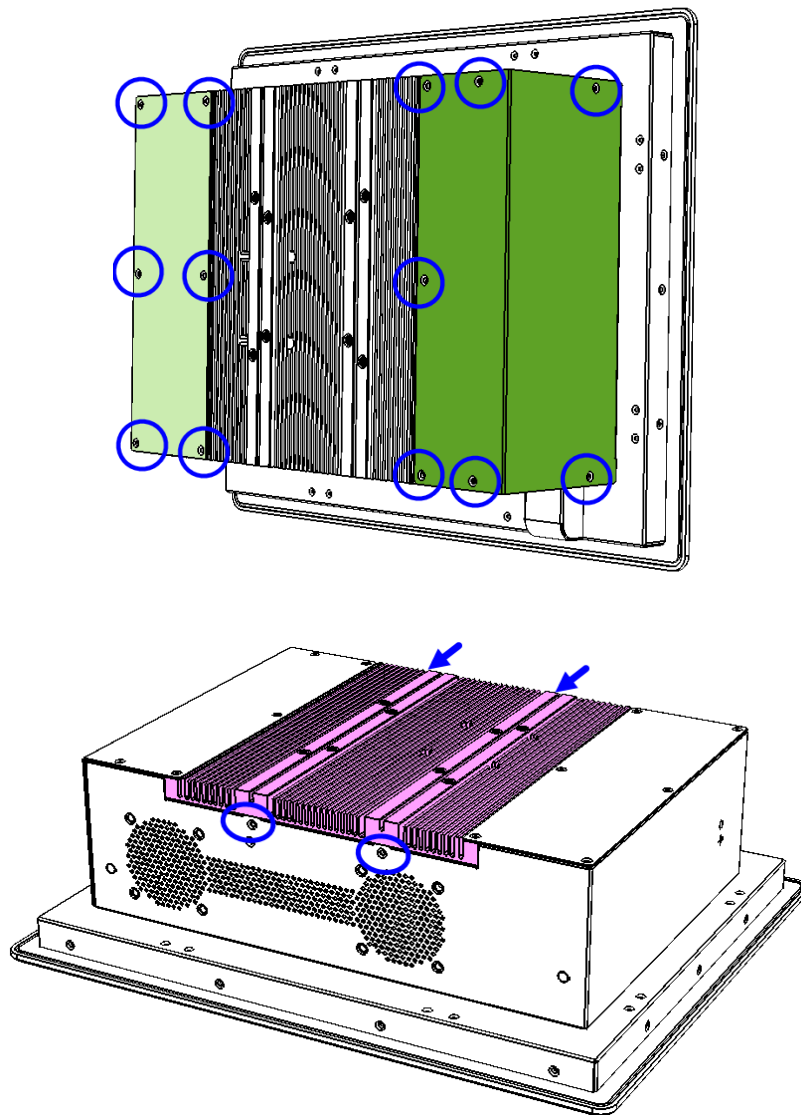

### 2.1.2 Memory Replacement

To replace or install memory modules, perform the following steps after removing the system rear cover.

1. Press the ejector tab of the memory slot outwards with your fingertips.



2. Hold the memory module and align the key of the module with that on the memory slot.
3. Gently push the module in an upright position until the ejector tabs of the memory slot close to hold the module in place when the module touches the bottom of the slot.

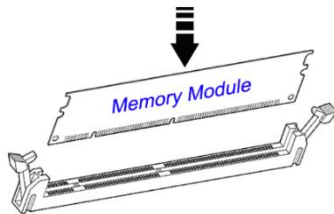

To remove the module, press the ejector tabs outwards with your fingertips to eject the module.

### 2.1.3 SSD Replacement

1. After removing the rear covers, unscrew the following 4 screws to remove an SSD tray.

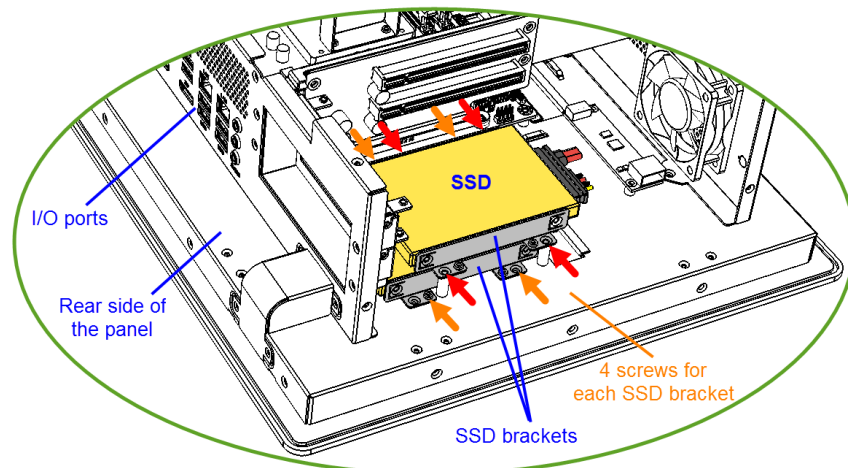

2. Unplug the cables of the SSD. Unscrew the 4 screws on the bottom of the tray to release the SSD and replace it with a new one.
3. Secure the new SSD to the tray, fix it onto the motherboard, and connect the cables.

## 2.1.4 Mini-PCle Installation

To replace or install a mini-PCle card, perform the following steps after removing the rear cover.

1. Locate the mini-PCle slot, align the key of the card to the interface, and insert the card slantwise.

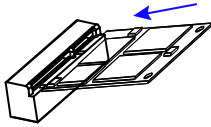

2. Push the card down and fix it with the supplied flat head screw.

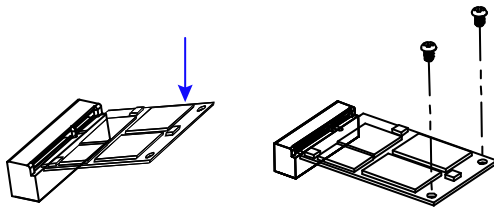

## 2.1.5 VESA Mounting Installation

You will need to prepare the VESA mount bracket in advance. Tighten 4 VESA screws as shown below to mount the device onto your VESA bracket.

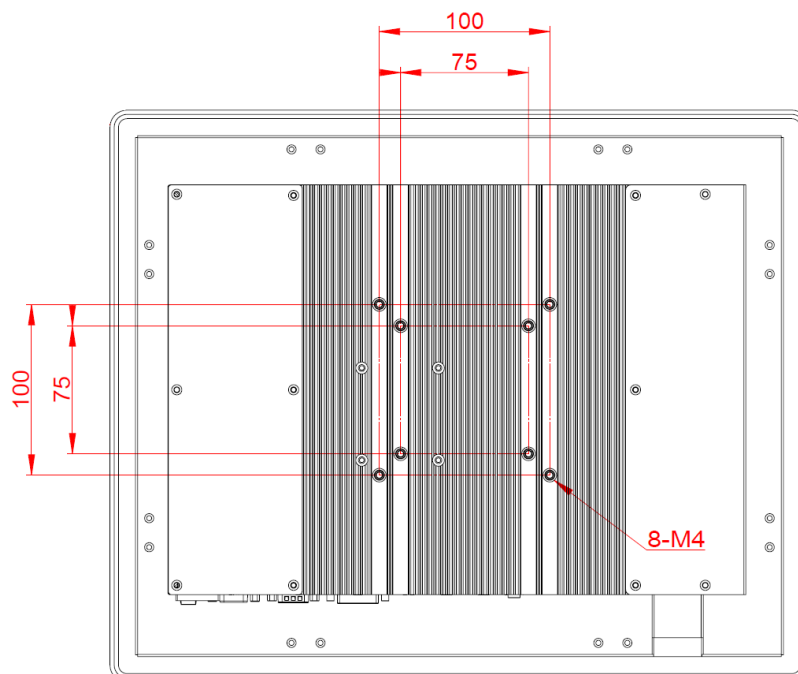

## 2.2 Pin out for COM1 & COM2



- **COM1 RS232/422/485 Port**

COM 1 is features jumperless selection for RS-232/422/485 and configurable in BIOS.

Pin	Signal Name	Pin	Signal Name
1	DCD, Data carrier detect	6	DSR, Data set ready
2	RXD, Receive data	7	RTS, Request to send
3	TXD, Transmit data	8	CTS, Clear to send
4	DTR, Data terminal ready	9	RI, Ring indicator
5	Ground		

Pin	Signal Name		
	RS-232	RS-422	RS-485
1	DCD	TX-	DATA-
2	RX	TX+	DATA+
3	TX	RX+	NC
4	DTR	RX-	NC
5	Ground	Ground	Ground
6	DSR	NC	NC
7	RTS	NC	NC
8	CTS	NC	NC
9	RI	NC	NC

- **COM2 RS-232 Port**

Pin	Signal Name	Pin	Signal Name
1	DCD, Data carrier detect	6	DSR, Data set ready
2	RXD, Receive data	7	RTS, Request to send
3	TXD, Transmit data	8	CTS, Clear to send
4	DTR, Data terminal ready	9	RI, Ring indicator
5	Ground		

## 2.3 Setting the Jumpers

Configure the jumpers with the settings required to be able to use the features needed for your application. Contact your supplier if you have doubts about the best configuration for your use.

### 2.3.1 How to Set the Jumpers

Jumpers are short-length conductors consisting of several metal pins with a non-conductive base mounted on the circuit board. Jumper caps are used to have the functions and features enabled or disabled. If a jumper has 3 pins, you can connect either PIN1 to PIN2 or PIN2 to PIN3 by shorting with the jumper cap.

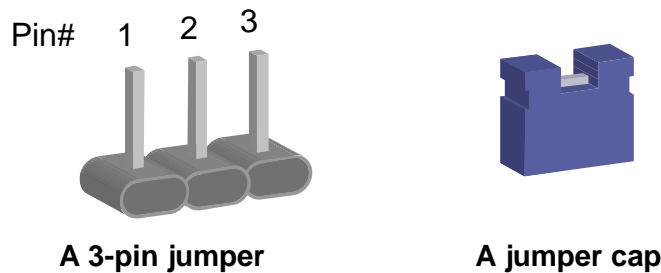

Refer to the illustration below to set the jumpers.

Pin closed	Oblique view	Illustration
Open		
1-2		
2-3		

When two pins of a jumper are encased in a jumper cap, this jumper is **closed**, i.e. turned **On**.

When a jumper cap is removed from two jumper pins, this jumper is **open**, i.e. turned **Off**.

## 2.4 Jumper & Connector Locations

Motherboard: MI992

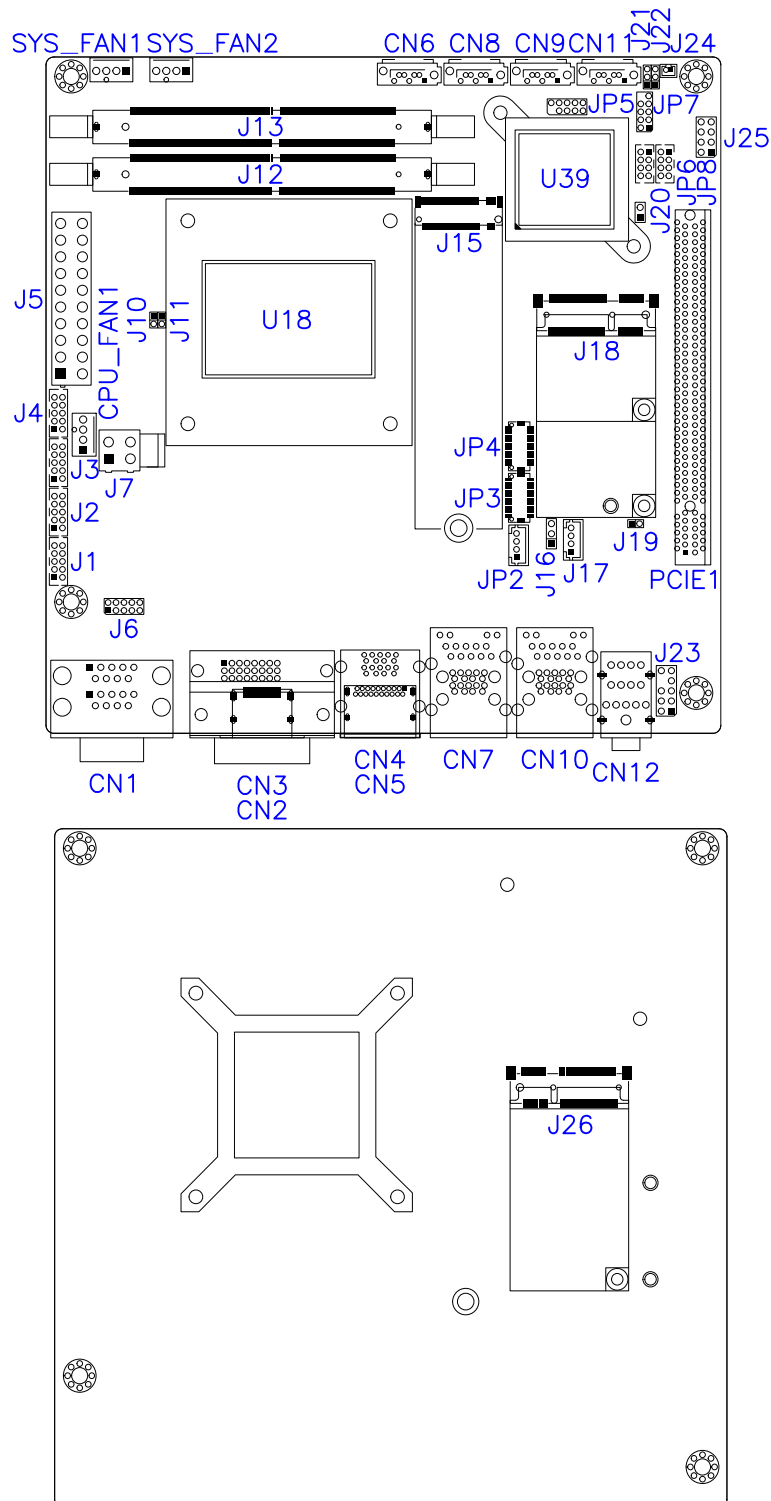

## 2.5 Jumpers Quick Reference

Function	Connector Name	Page
LVDS Power Selection	J16	18
PCIe (x16) Bifurcation Selection	J10, J11	19
ME Register Clearance	J21	20
CMOS Data Clearance	J22	21
Factory Use Only	J20	--

### 2.5.1 LVDS Power Selection (J16)

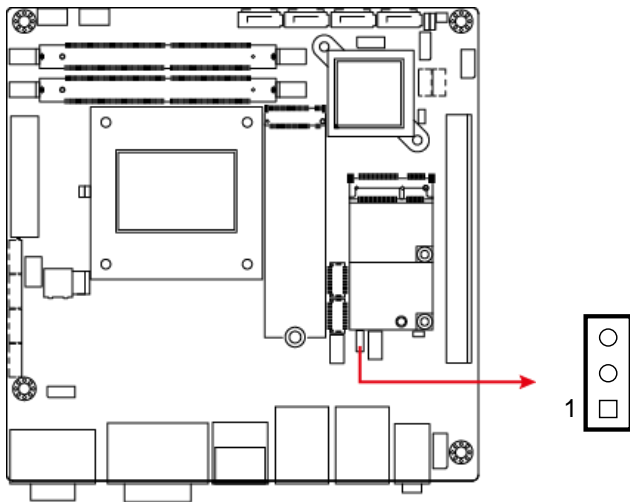

Function	Pin closed	Illustration
3.3V (default)	1-2	
5V	2-3	

### 2.5.2 PCIe (x16) Bifurcation Selection (J10 & J11)

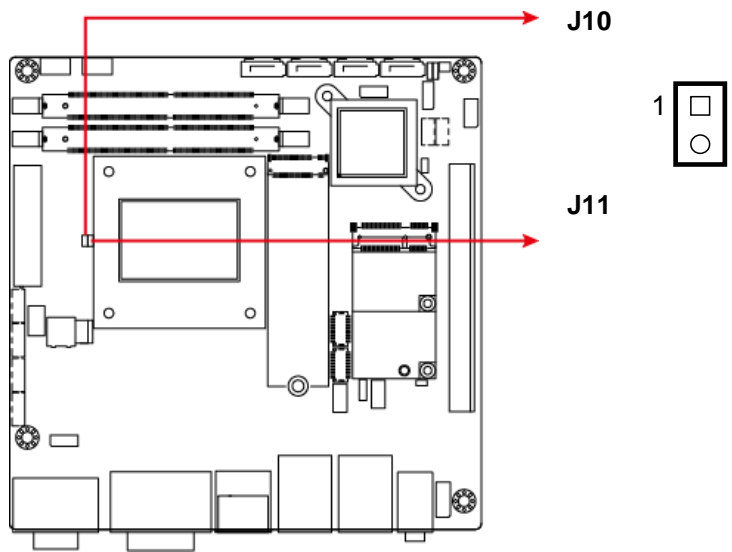

Function	Pin closed	Illustration
1 x PCIe (x16) (default)	J10: Open	1
	J11: Open	1
2 x PCIe (x8)	J10: Open	1
	J11: Close	1
1 x PCIe (x8) 2 x PCIe (x4)	J10: Close	1
	J11: Close	1

**2.5.3 Clearing ME Register (J21)**

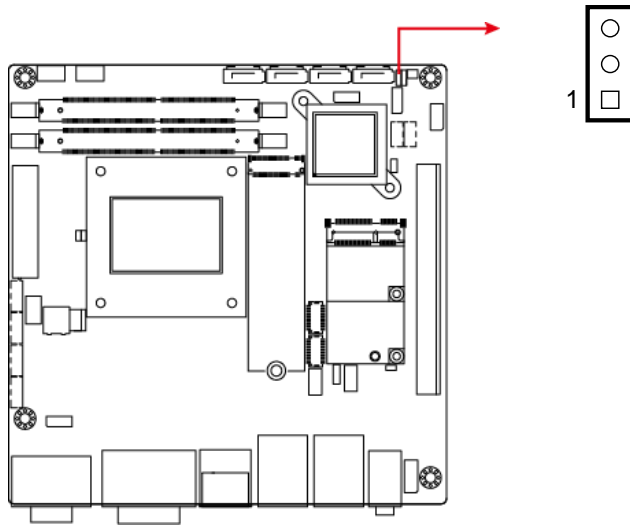

Function	Pin closed	Illustration
Normal (default)	1-2	
Clear ME	2-3	

### 2.5.4 Clearing CMOS Data (J22)

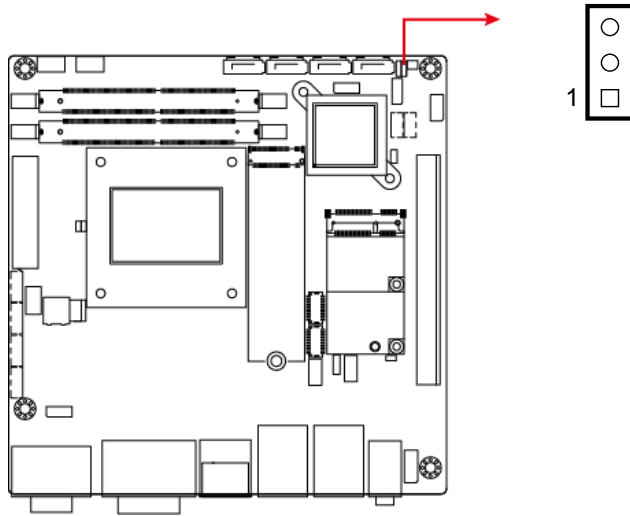

Function	Pin closed	Illustration
Normal (default)	1-2	
Clear CMOS	2-3	

## 2.6 Connectors Quick Reference

Function	Connector Name	Page
COM1 & COM2 RS-232/422/485 Ports	CN1	23
COM3 ~ COM6 RS-232 Ports	J1 (COM6), J2 (COM5), J3 (COM4), J4 (COM3)	24
20-pin ATX Power Connector	J5	25
Digital I/O Connector	J6	26
4-pin ATX 12V Power Connector	J7	26
Battery Connector	J24	27
Front Panel Audio Connector	J23	27
Front Panel Settings Connector	J25	28
LCD Backlight Connector	JP2	29
LVDS Connector	JP3, JP4	29
USB 2.0 Connector	JP6, JP8	30
CPU Fan Power Connector	CPU_FAN1	30
System Fan Power Connector	SYS_FAN1, SYS_FAN2	31
DDR4 SO-DIMM Slot	J12, J13	--
M.2 M2280 slot	J15	--
Mini-PCIe / mSATA Slot	J18, J26*	--
HDMI Port	CN2	--
DVI-D	CN3	--
USB 3.0 Port	CN4	--
DisplayPort	CN5	--
SATA 3.0 Port	CN6*, CN8*, CN9, CN11	--
GbE LAN & USB 3.0 Ports	CN7, CN10	--
HD Audio Connector	CN12	--
Factory Use Only	J20, JP5, JP7	--

\* CN6, CN8, and J26 are only available for MI992VF only.

### 2.6.1 COM1 & COM2 RS-232/422/485 Ports (CN1)

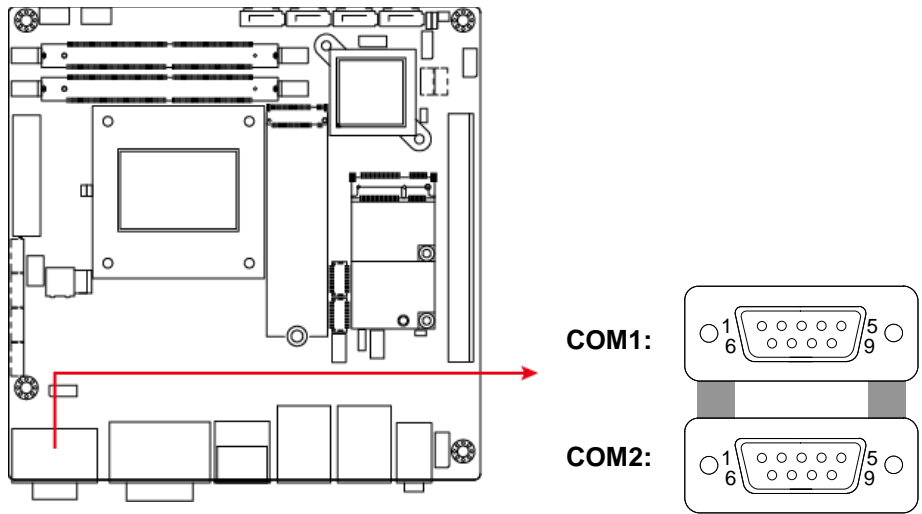

Pin	Signal Name	Pin	Signal Name
1	DCD, Data carrier detect	6	DSR, Data set ready
2	RXD, Receive data	7	RTS, Request to send
3	TXD, Transmit data	8	CTS, Clear to send
4	DTR, Data terminal ready	9	RI, Ring indicator
5	Ground		

Pin	Signal Name		
	RS-232	RS-422	RS-485
1	DCD	TX-	DATA-
2	RX	TX+	DATA+
3	TX	RX+	NC
4	DTR	RX-	NC
5	Ground	Ground	Ground
6	DSR	NC	NC
7	RTS	NC	NC
8	CTS	NC	NC
9	RI	NC	NC

**2.6.2 COM3 ~ COM6 RS-232 Ports (J1, J2, J3, J4)**

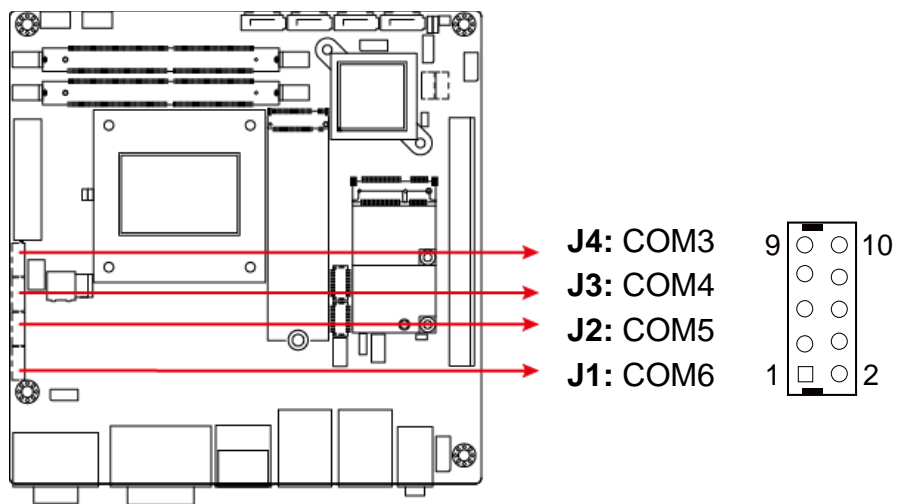

Pin	Signal Name	Pin	Signal Name
1	DCD#	2	SIN#
3	SOUT	4	DSR#
5	GND	6	DTR#
7	RTS#	8	CTS#
9	RI#	10	KEY

## 2.6.3 20-pin ATX Power Connector (J5)

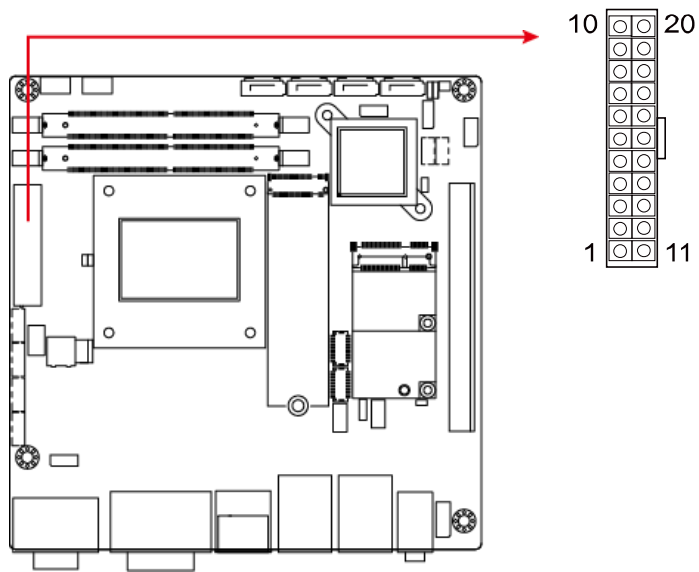

Pin	Signal Name	Pin	Signal Name
1	3.3V	11	3.3V
2	3.3V	12	-12V
3	Ground	13	Ground
4	+5V	14	PS-ON
5	Ground	15	Ground
6	+5V	16	Ground
7	Ground	17	Ground
8	Power good	18	-5V
9	5VSB	19	+5V
10	+12V	20	+5V

**2.6.4 Digital I/O Connector (J6)**

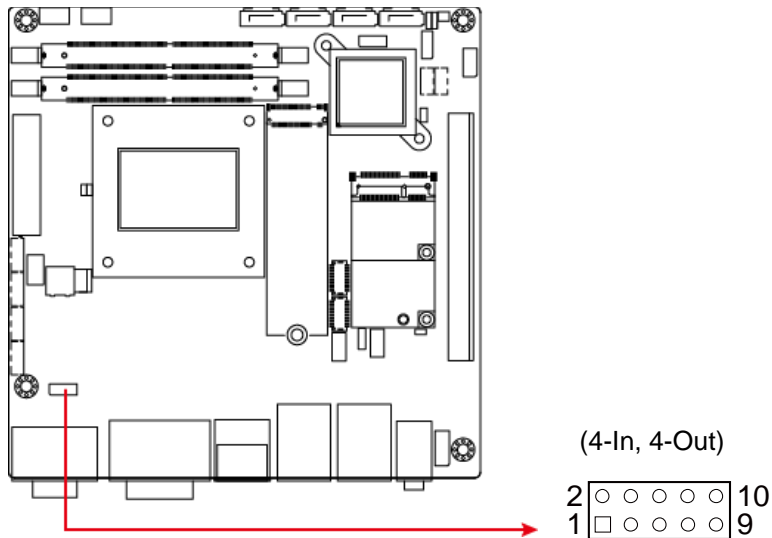

Pin	Signal Name	Pin	Signal Name
1	Ground	2	+5V
3	Out3	4	Out1
5	Out2	6	Out0
7	IN3	8	IN1
9	IN2	10	IN0

**2.6.5 4-pin ATX 12V Power Connector (J7)**

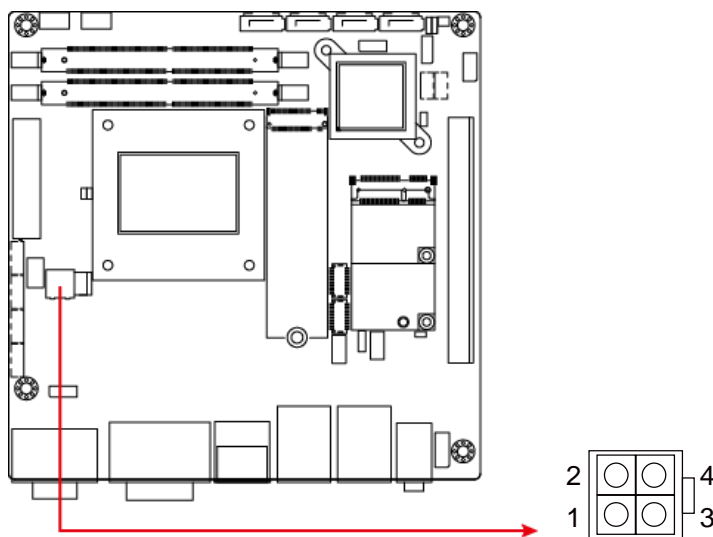

Pin	Signal Name	Pin	Signal Name
1	Ground	3	+12V
2	Ground	4	+12V

### 2.6.6 Battery Connector (J24)

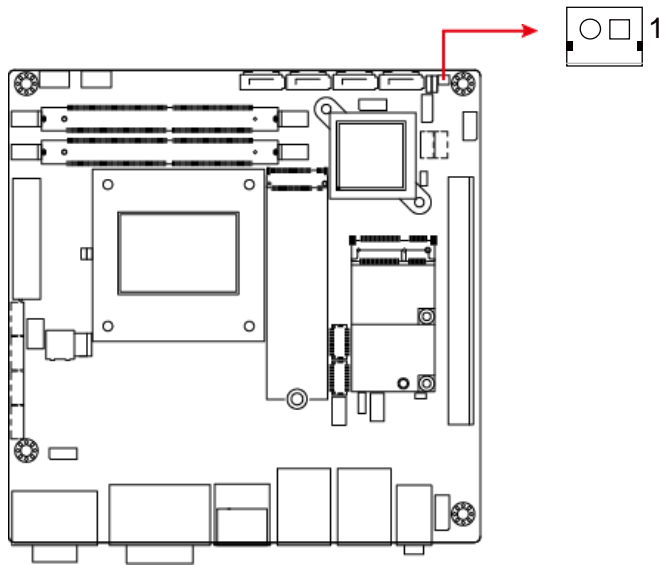

Pin	Signal Name	Pin	Signal Name
1	Battery+	2	Ground

### 2.6.7 Front Panel Audio Connector (J23)

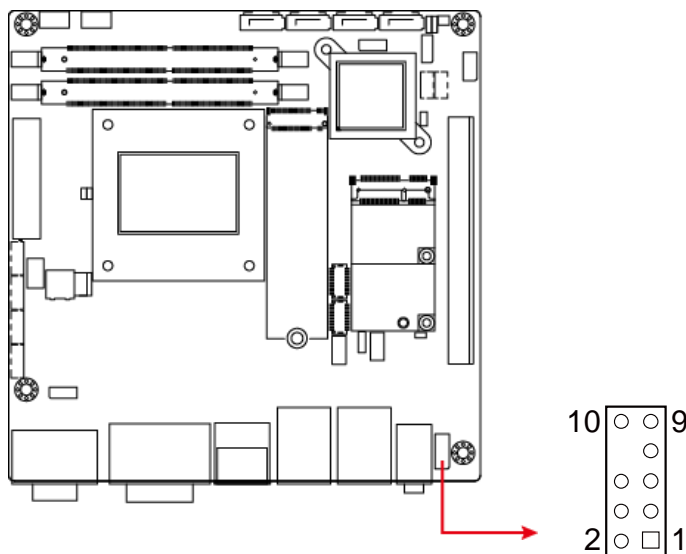

Pin	Signal Name	Pin	Signal Name
1	MIC IN_L	2	Ground
3	MIC IN_R	4	DET
5	LINE_R	6	Ground
7	Sense	8	KEY
9	LINE_L	10	Ground

**2.6.8 Front Panel Settings Connector (J25)**

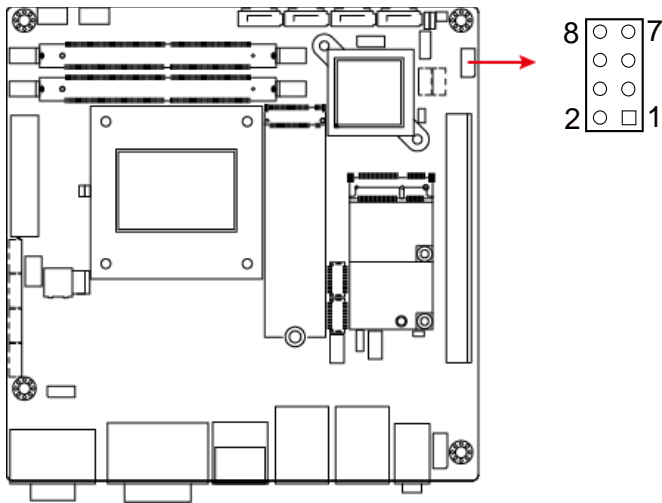

Pin	Signal Name	Pin	Signal Name
1	Power BTN	2	Power BTN
3	HDD LED+	4	HDD LED-
5	Reset BTN	6	Reset BTN
7	Power LED+	8	Power LED-

J25 is utilized for system indicators to provide light indication of the computer activities and switches to change the computer status. It provides interfaces for the following functions.

- ATX Power ON Switch (Pins 1 and 2)**

The 2 pins make an “ATX Power Supply On/Off Switch” for the system that connects to the power switch on the case. When pressed, the power switch will force the system to power on. When pressed again, it will power off the system.
- Hard Disk Drive LED Connector (Pins 3 and 4)**

This connector connects to the hard drive activity LED on control panel. This LED will flash when the HDD is being accessed.
- Reset Switch (Pins 5 and 6)**

The reset switch allows you to reset the system without turning the main power switch off and then on again. Orientation is not required when making a connection to this header.
- Power LED (Pins 7 and 8)**

This connector connects to the system power LED on control panel. This LED will light when the system turns on.

### 2.6.9 LCD Backlight Connector (JP2)

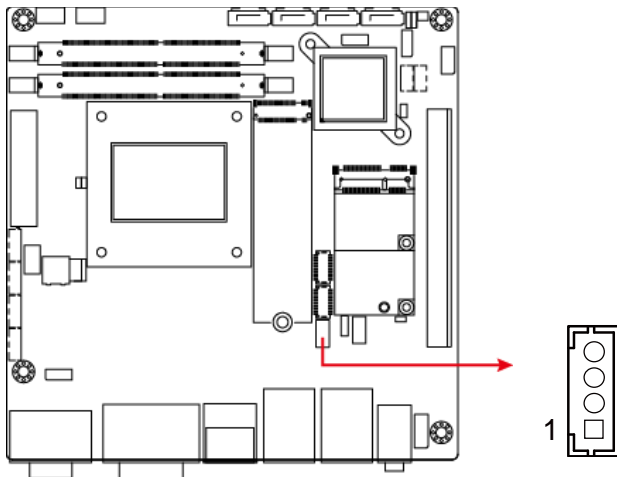

Pin	Signal Name	Pin	Signal Name
1	+12V	3	Brightness Control
2	Backlight Enable	4	Ground

### 2.6.10 LVDS Connector (JP3, JP4)

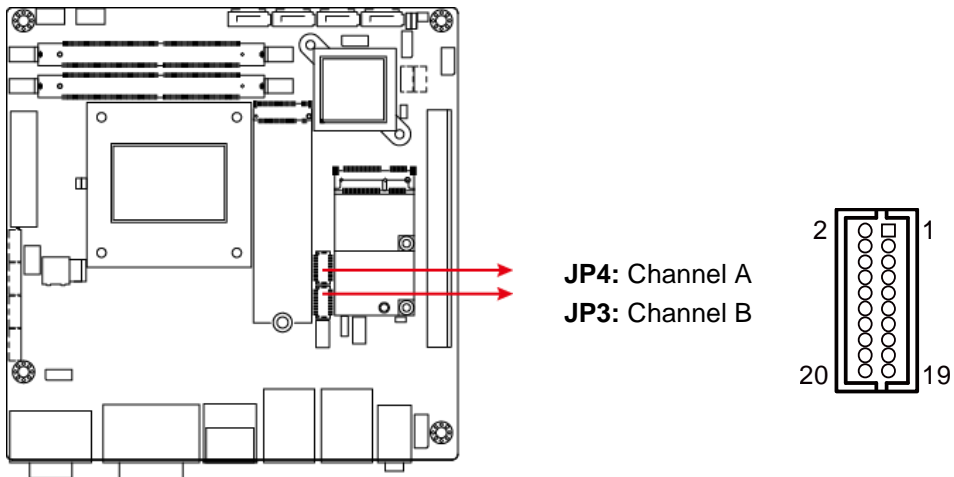

Pin	Signal Name	Pin	Signal Name
1	TX0P	2	TX0N
3	Ground	4	Ground
5	TX1P	6	TX1N
7	Ground	8	Ground
9	TX2P	10	TX2N
11	Ground	12	Ground
13	CLKP	14	CLKN
15	Ground	16	Ground
17	TX3P	18	TX3N
19	Power	20	Power

**2.6.11 USB 2.0 Connector (JP6, JP8)**

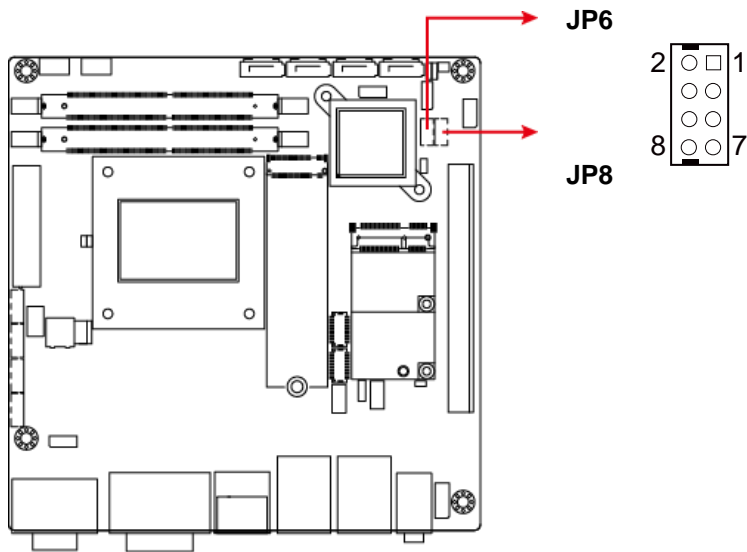

Pin	Signal Name	Pin	Signal Name
1	VCC	2	Ground
3	D0-	4	D1+
5	D0+	6	D1-
7	Ground	8	VCC

**2.6.12 CPU Fan Power Connector (CPU\_FAN1)**

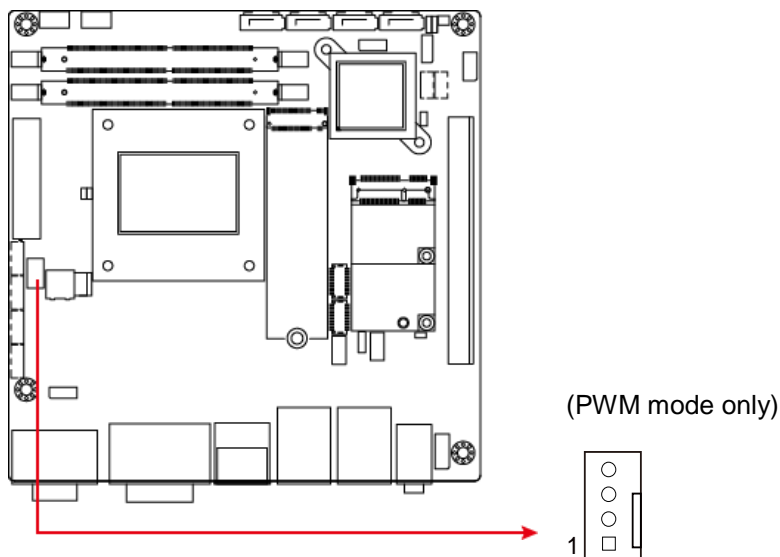

Pin	Signal Name	Pin	Signal Name
1	Ground	3	Rotation detection
2	+12V	4	Control

2.6.13 System Fan Power Connector (SYS\_FAN1, SYS\_FAN2)

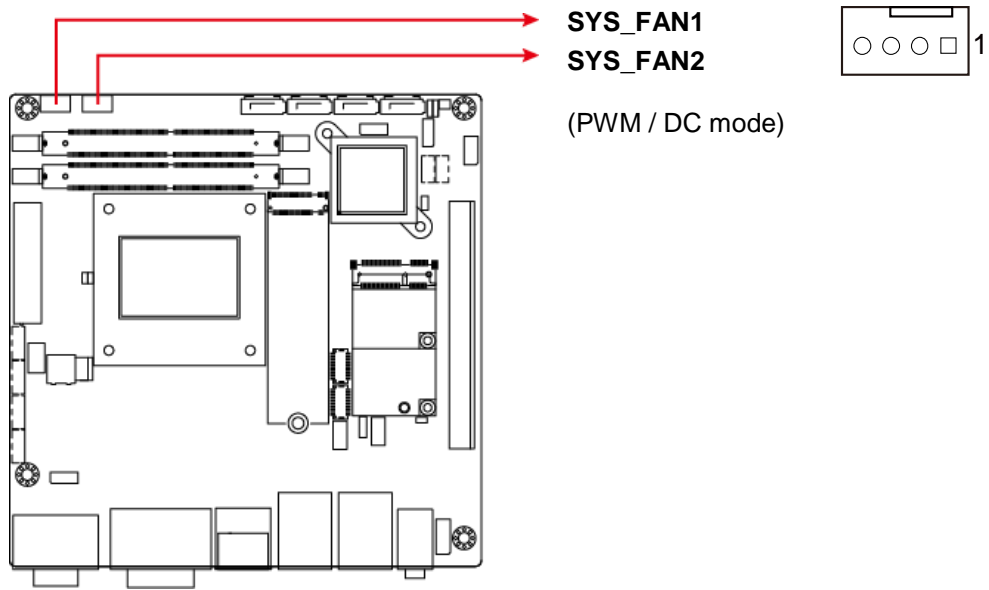

Pin	Signal Name	Pin	Signal Name
1	Ground	3	Rotation detection
2	+12V	4	Control

## Chapter 3

# Driver Installation

The information provided in this chapter includes:

- Intel® Chipset Software Installation Utility
- HD Graphics Driver
- HD Audio Driver
- LAN Driver
- Intel® Management Engine Drivers

### 3.1 Introduction

This section describes the installation procedures for software drivers. The software drivers are available on IBASE website [www.ibase.com.tw](http://www.ibase.com.tw). Register as a member on our website to download all the necessary drivers.

---

**Note:** After installing your Windows operating system, you must install the Intel® Chipset Software Installation Utility first before proceeding with the drivers installation.

---

### 3.2 Intel® Chipset Software Installation Utility

The Intel® Chipset drivers should be installed first before the software drivers to install INF files for Plug & Play function for the chipset components. Follow the instructions below to complete the installation.

1. Insert the disk enclosed in the package with the board. Click **Intel** on the left pane and then **Intel(R) Skylake/Kabylake Chipset Drivers** on the right pane.



2. Click **Intel(R) Chipset Software Installation Utility**.



# iBASE

3. When the *Welcome* screen to the Intel® Chipset Device Software appears, click **Next** to continue.
4. Accept the software license agreement and proceed with the installation process.
5. On the *Readme File Information* screen, click **Install** for installation.
6. After the driver is completely installed, restart the computer for changes to take effect.

## 3.3 HD Graphics Driver Installation

1. Click **Intel** on the left pane and then **Intel(R) Skylake/Kabylake Chipset Drivers** on the right pane.



2. Click **Intel(R) HD Graphics Driver**.



- When the *Welcome* screen appears, click **Next** to continue.

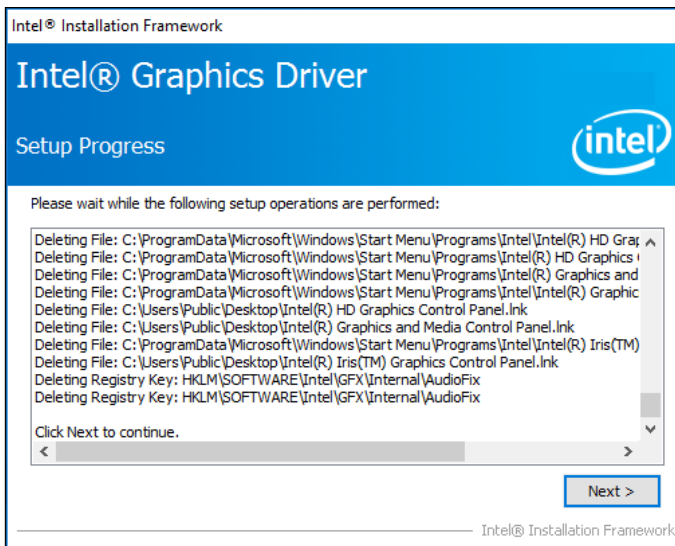

- Accept the license agreement and click **Next**.
- On the *Readme File Information* screen, click **Next** until the installation starts.
- After the driver is completely installed, restart the computer for changes to take effect.

### 3.4 HD Audio Driver Installation

- Click **Intel** on the left pane and then **Intel(R) Skylake/Kabylake Chipset Drivers** on the right pane.



2. Click **Realtek High Definition Audio Driver**.



3. On the *Welcome* screen of the InstallShield Wizard, click **Next**.
4. Click **Next** until the installation starts.
5. After the driver is completely installed, restart the computer for changes to take effect.

## 3.5 LAN Driver Installation

1. Click **Intel** on the left pane and then **Intel(R) Skylake/Kabylake Chipset Drivers** on the right pane.



2. Click **Intel(R) PRO LAN Network Drivers**.



- When the *Welcome* screen appears, click **Next**.

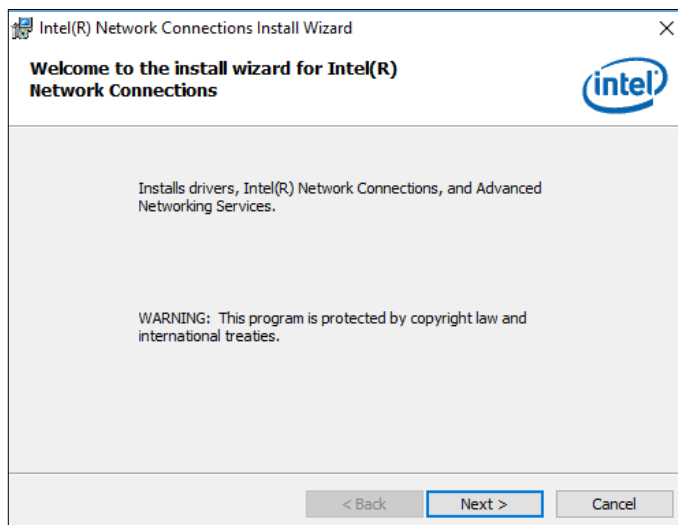

- Accept the license agreement and click **Next**.
- On the Setup Options screen, click the checkbox to select the desired driver(s) for installation. Then click **Next** to continue.

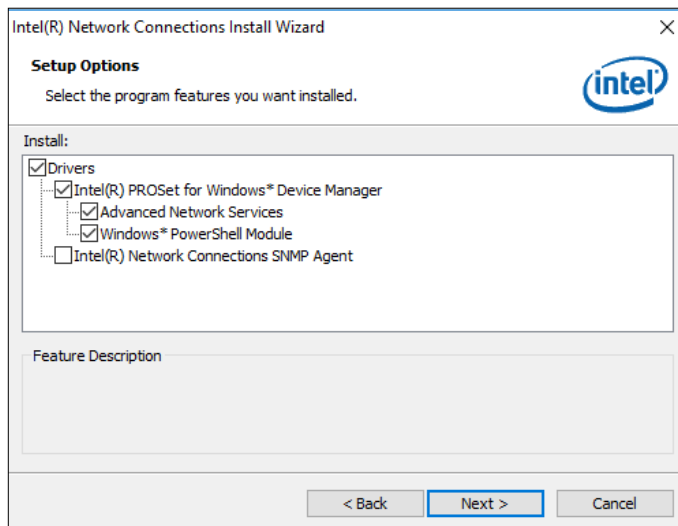

- The wizard is ready for installation. Click **Install**.
- As the installation is complete, restart the computer for changes to take effect.

## 3.6 Intel® Management Engine Driver Installation

1. Click **Intel** on the left pane and then **Intel(R) Skylake/Kabylake Chipset Drivers** on the right pane.



2. Click **Intel(R) ME 11.x Drivers**.



3. When the *Welcome* screen appears, click **Next**.

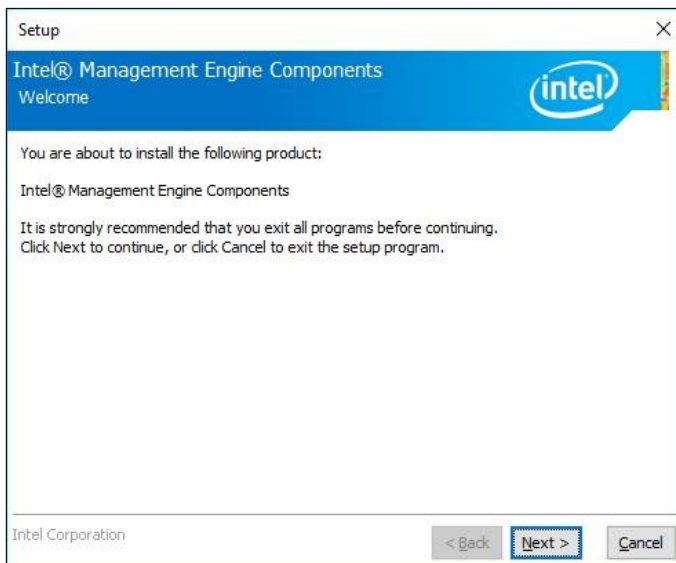

4. Accept the license agreement and click **Next** until the installation starts.
5. After the installation is complete, restart the computer for changes to take effect.

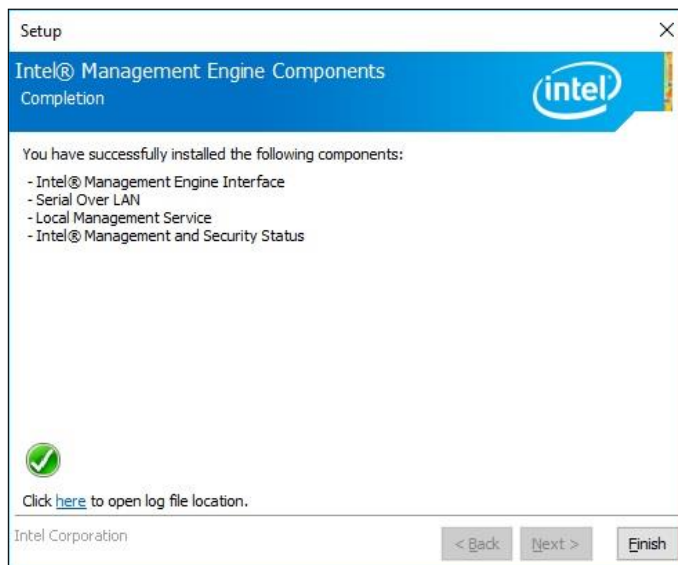

## Chapter 4

# BIOS Setup

This chapter describes the different settings available in the AMI BIOS that comes with the board. The topics covered in this chapter are as follows:

- Main Settings
- Advanced Settings
- Chipset Settings
- Security Settings
- Boot Settings
- Save & Exit

## 4.1 Introduction

The BIOS (Basic Input/Output System) installed in the ROM of your computer system supports Intel® processors. The BIOS provides critical low-level support for standard devices such as disk drives, serial ports and parallel ports. It also provides password protection as well as special support for detailed fine-tuning of the chipset controlling the entire system.

## 4.2 BIOS Setup

The BIOS provides a Setup utility program for specifying the system configurations and settings. The BIOS ROM of the system stores the Setup utility. When you turn on the computer, the BIOS is immediately activated. Press the <Del> key immediately allows you to enter the Setup utility. If you are a little bit late pressing the <Del> key, POST (Power On Self Test) will continue with its test routines, thus preventing you from invoking the Setup.

If you still need to enter Setup, restart the system by pressing the "Reset" button or simultaneously pressing the <Ctrl>, <Alt> and <Delete> keys. You can also restart by turning the system Off and back On again.

The following message will appear on the screen:

```
Press <DEL> to Enter Setup
```

In general, press the arrow keys to highlight items, <Enter> to select, the <PgUp> and <PgDn> keys to change entries, <F1> for help, and <Esc> to quit.

When you enter the BIOS Setup utility, the *Main Menu* screen will appear on the screen. The Main Menu allows you to select from various setup functions and exit choices.

---

**Warning:** It is strongly recommended that you avoid making any changes to the chipset defaults.

These defaults have been carefully chosen by both AMI and your system manufacturer to provide the absolute maximum performance and reliability. Changing the defaults could make the system unstable and crash in some cases.

---

### 4.3 Main Settings

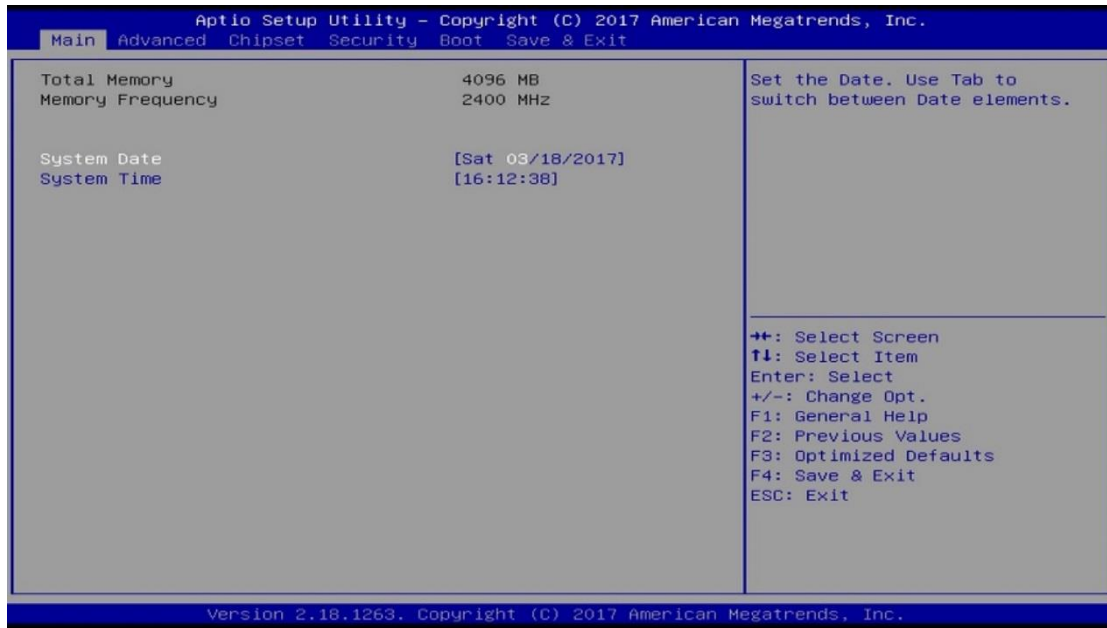

BIOS Setting	Description
System Date	Sets the date. Use the <Tab> key to switch between the data elements.
System Time	Set the time. Use the <Tab> key to switch between the data elements.

## 4.4 Advanced Settings

This section allows you to configure, improve your system and allows you to set up some system features according to your preference.

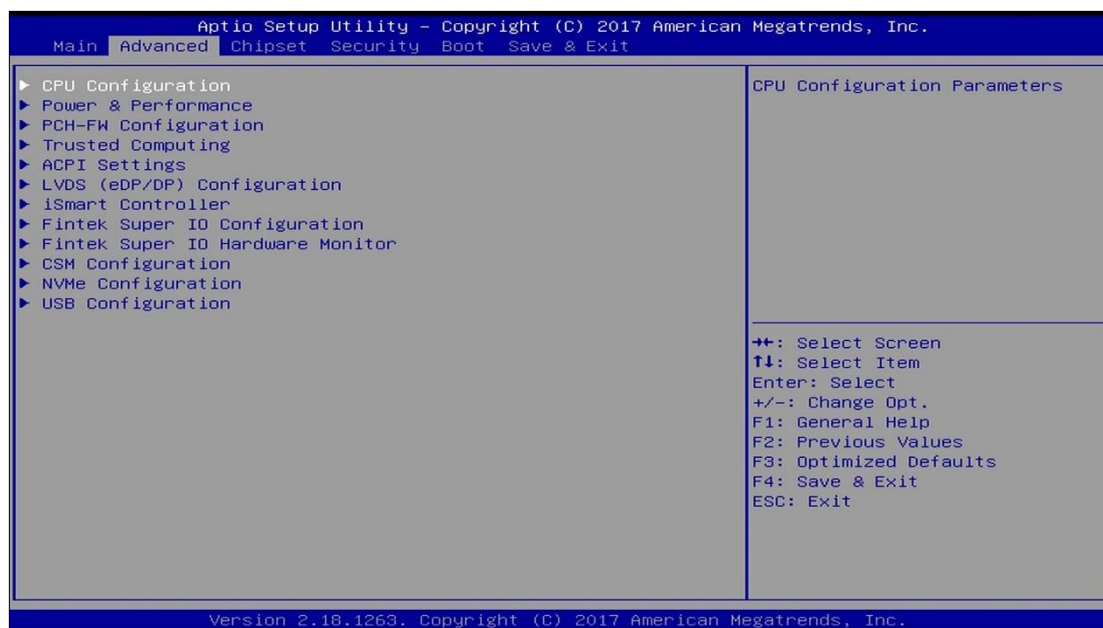

BIOS Setting	Description
CPU Configuration	Displays CPU configuration parameters.
PCH-FW Configuration	Configures management engine technology parameters.
Trusted Computing*	Trusted computing settings.
ACPI Settings	Displays system ACPI parameters.
LVDS (eDP/DP) Configuration	Configures LVDS (eDP/DP).
iSmart Controller	Sets up the power on time for the system.
Fintek Super IO Configuration	Displays super IO chip parameters.
Fintek Super IO Hardware Monitor	Shows super IO monitor hardware status.
CSM Configuration	Enables / Disables option ROM execution settings, etc.
NVMe Configuration	NVMe device option settings.
USB Configuration	Displays USB configuration parameters.

\* Trusted Computing is available for MI992VF series only.

### 4.4.1 CPU Configuration

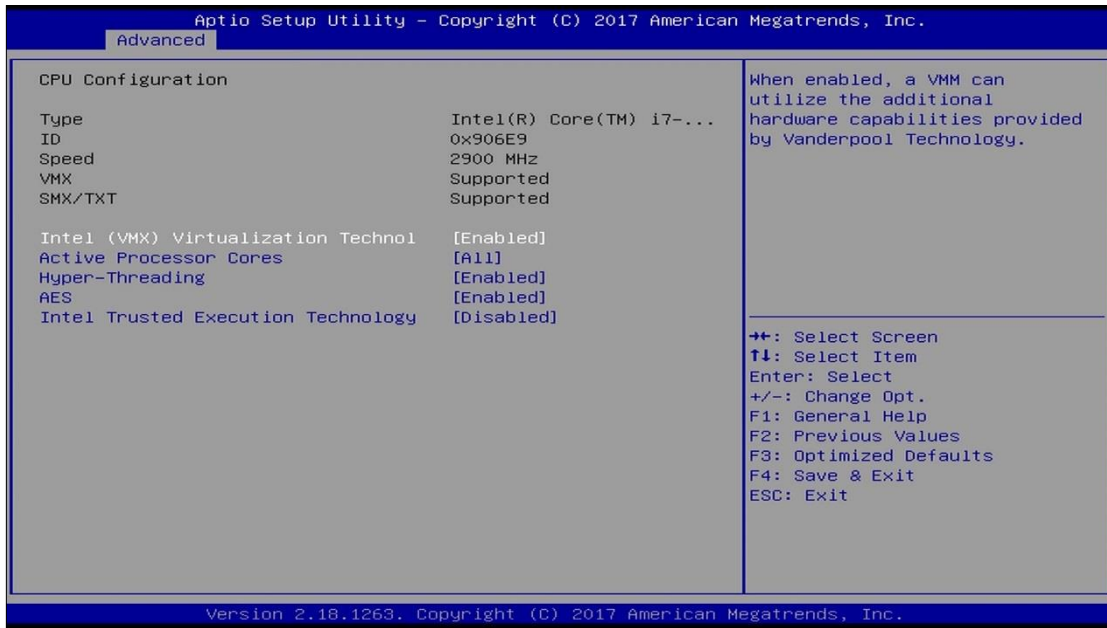

BIOS Setting	Description
Intel (VMX) Virtualization Technology	Enables / Disables a VMM to utilize the additional hardware capabilities provided by Vanderpool Technology.
Active Processor Cores	Number of cores to enable in each processor package. Options: All, 1, 2, 3
Hyper-Threading	Enabled for Windows XP and Linux (OS optimized for Hhyper-Threading Technology) and Disabled for other OS (OS not optimized for Hyper-Threading Technology).
AES	Enables / Disables AES (Advanced Encryption Standard).
Intel Trusted Execution Technology	Enables / Disables utilization of additional hardware capabilities provided by Intel(R) Trusted Execution Technology. Changes require a full power cycle to take effect.

### 4.4.2 PCH-FW Configuration

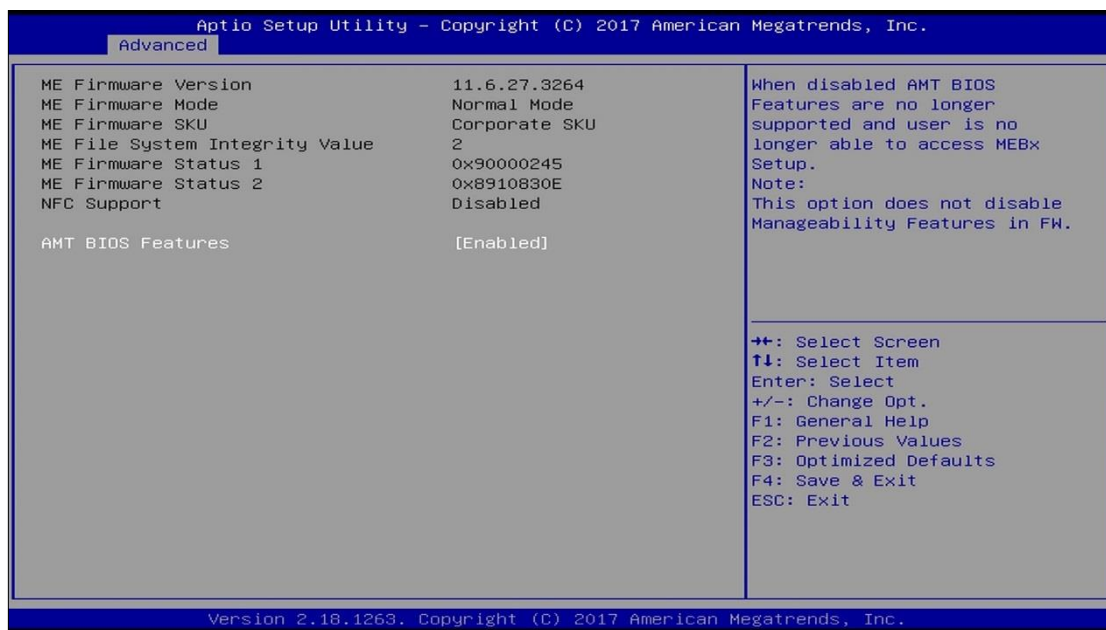

BIOS Setting	Description
AMT BIOS Features*	When disabled AMT BIOS features are no longer supported and user is no longer able to access MEBx Setup. Note: This option does not disable Manageability features in FM.

\* AMT BIOS Features is available for MI992VF series only.

### 4.4.3 Trusted Computing

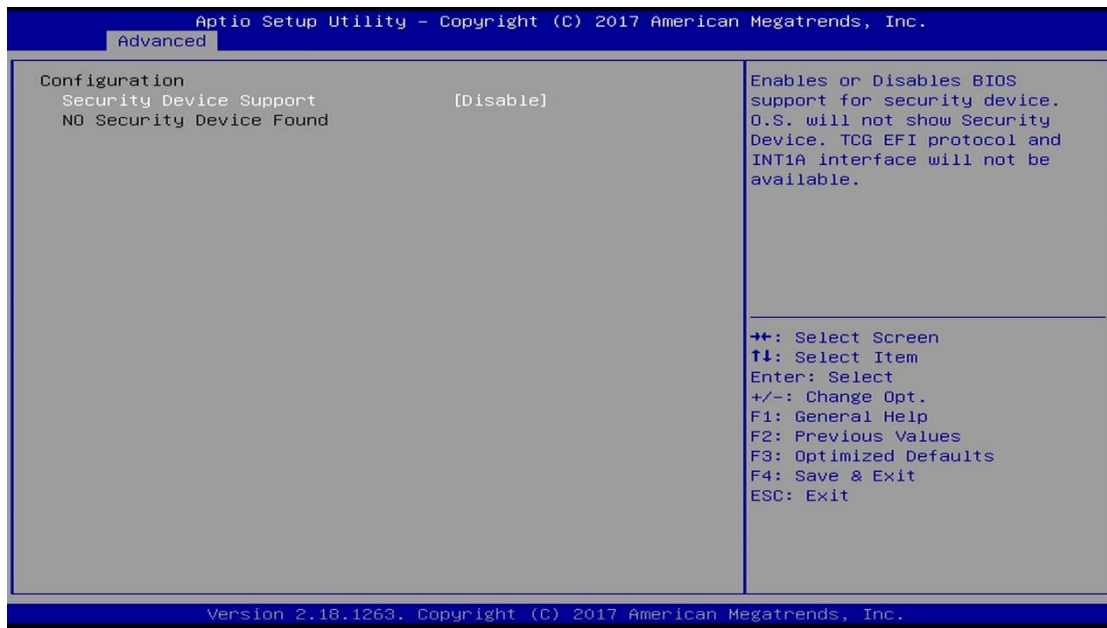

**Note:** PCH-FW Configuration is only available for MI992VF only.

BIOS Setting	Description
Security Device Support	Enables / Disables BIOS support for security device. OS will not show security device. TCG EFI protocol and INTIA interface will not be available.

### 4.4.4 ACPI Settings

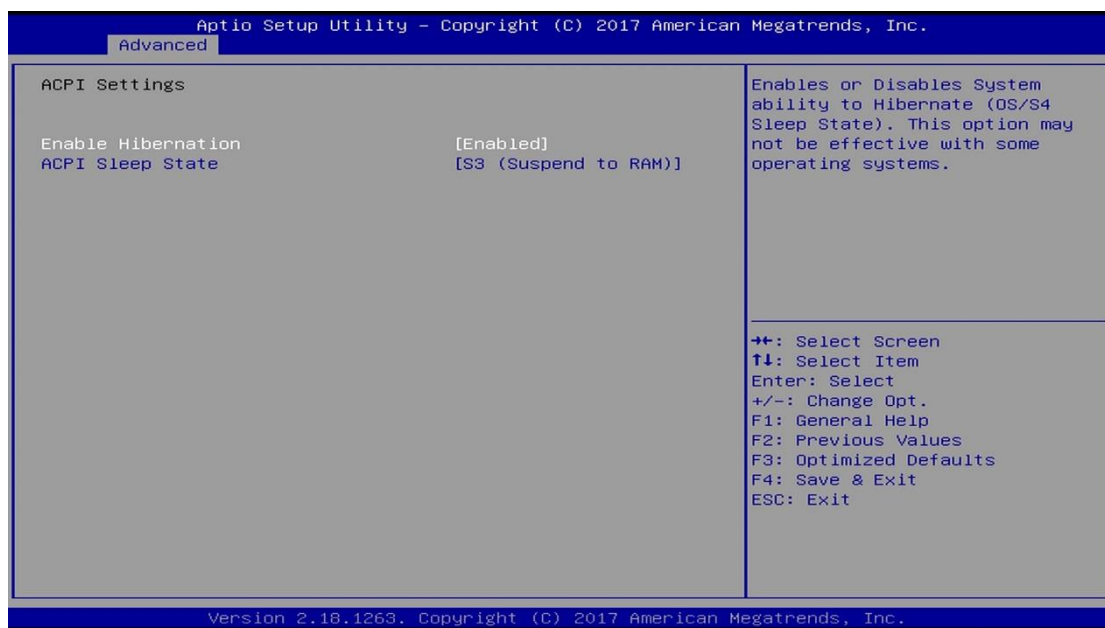

BIOS Setting	Description
Enable Hibernation	Enables / Disables the system ability to hibernate (OS/S4 Sleep State). This option may not be effective with some OS.
ACPI Sleep State	Selects a ACPI sleep state for the system to enter. Options: Suspend Disabled, S3 (Suspend to RAM)

### 4.4.5 LVDS (eDP/DP) Configuration

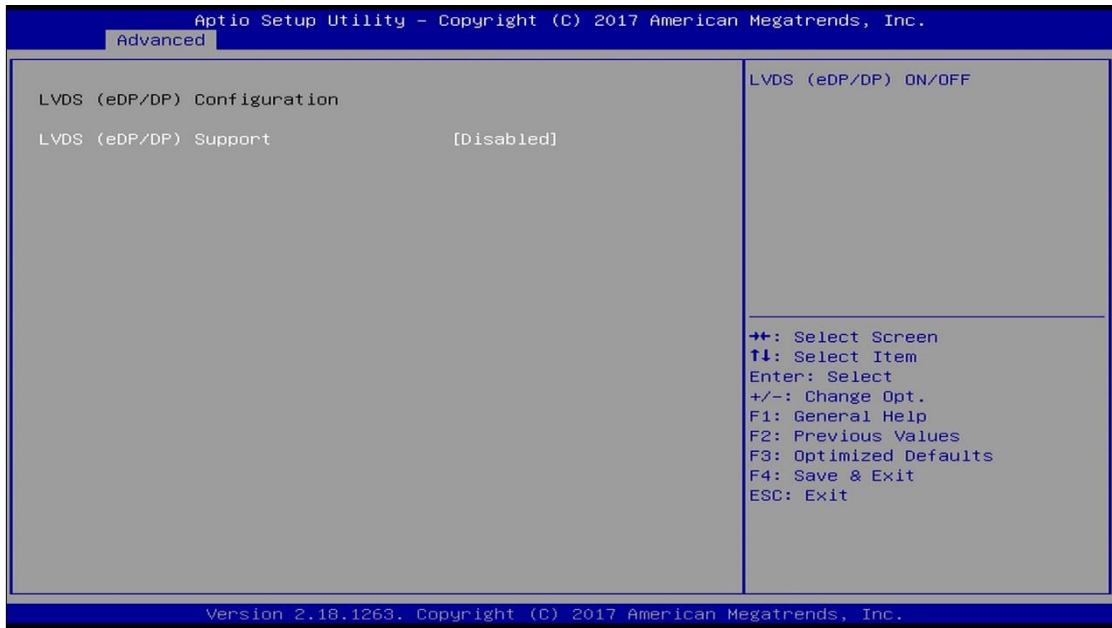

BIOS Setting	Description
LVDS (eDP/DP) Support	Enables / Disables LVDS (eDP/DP).

## 4.4.6 iSmart Controller



BIOS Setting	Description
Power-On after Power failure	Enables / Disables the system to be turned on automatically after a power failure.
Temperature Guardian	Generate the reset signal when system hands up on POST.
Schedule Slot 1 / 2	<p>Sets up the hour / minute / day for the power-on schedule for the system.</p> <p>Options:</p> <ul style="list-style-type: none"> <li>• None</li> <li>• Power On</li> <li>• Power On / Off</li> </ul> <p><b>Important:</b> If you would like to set up a schedule between adjacent days, configure two schedule slots.</p> <p>For example, if setting up a schedule from Wednesday 5 p.m. to Thursday 2 a.m., configure two schedule slots. But if setting up a schedule from 3 p.m to 5 p.m. on Wednesday, configure only a schedule slot.</p>

### 4.4.7 Fintek Super IO Configuration

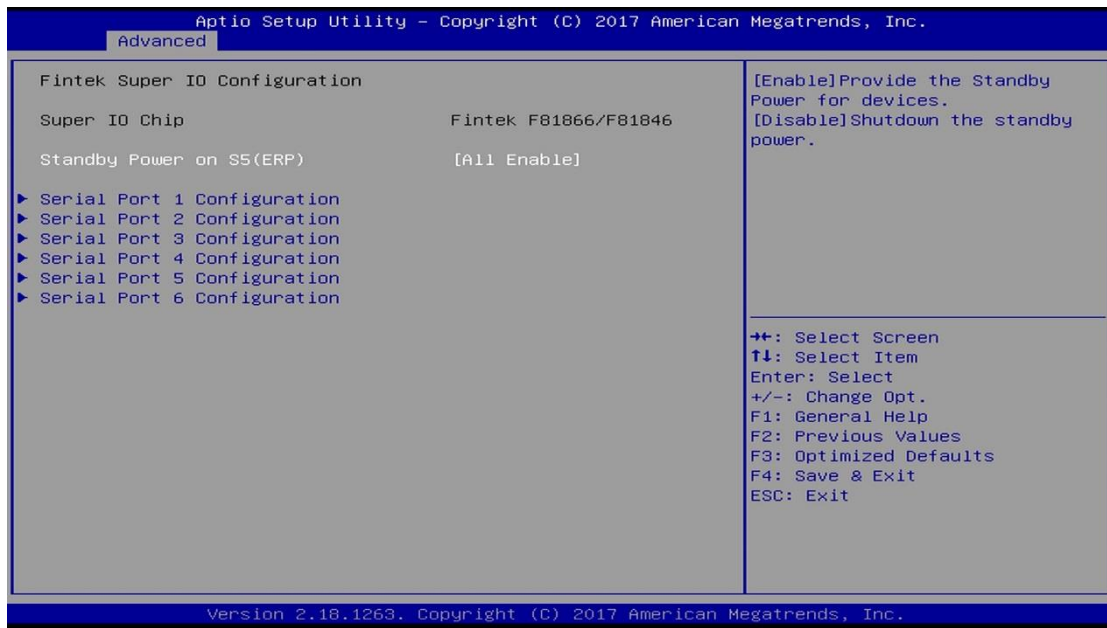

BIOS Setting	Description
Standby Power on S5 (ErP)*	Enable the function to provide the standby power for device. Disable the function to shutdown the standby power. Options: All Enable, Enable Ethernet for WOL, All Disable.
Serial Port Configuration	Sets parameters of Serial Ports. Enables / Disables the serial port and select an optimal setting for the Super IO device.

### 4.4.7.1. Serial Port 1 Configuration

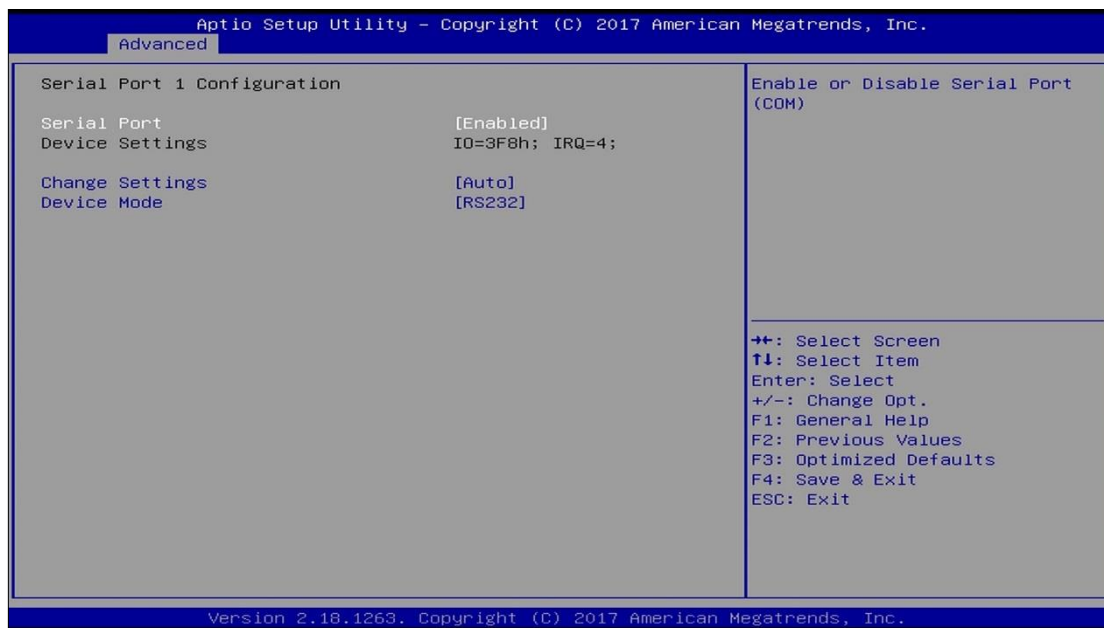

BIOS Setting	Description
Serial Port	Enables / Disables the serial port.
Change Settings	Selects an optimal settings for Super I/O device. Options: <ul style="list-style-type: none"> <li>• Auto</li> <li>• IO = 3F8h; IRQ = 4</li> <li>• IO = 3F8h; IRQ = 3, 4, 5, 6, 7, 9, 10, 11, 12</li> <li>• IO = 2F8h; IRQ = 3, 4, 5, 6, 7, 9, 10, 11, 12</li> <li>• IO = 3E8h; IRQ = 3, 4, 5, 6, 7, 9, 10, 11, 12</li> <li>• IO = 2E8h; IRQ = 3, 4, 5, 6, 7, 9, 10, 11, 12</li> </ul>
Device Mode Select	Changes the serial port mode to RS-232 / 422 / 485. Options: <ul style="list-style-type: none"> <li>• RS232</li> <li>• RS485 TX Low Active</li> <li>• RS485 with Termination TX Low Active</li> <li>• RS422</li> <li>• RS422 with Termination</li> </ul>

**4.4.7.2. Serial Port 2 Configuration**

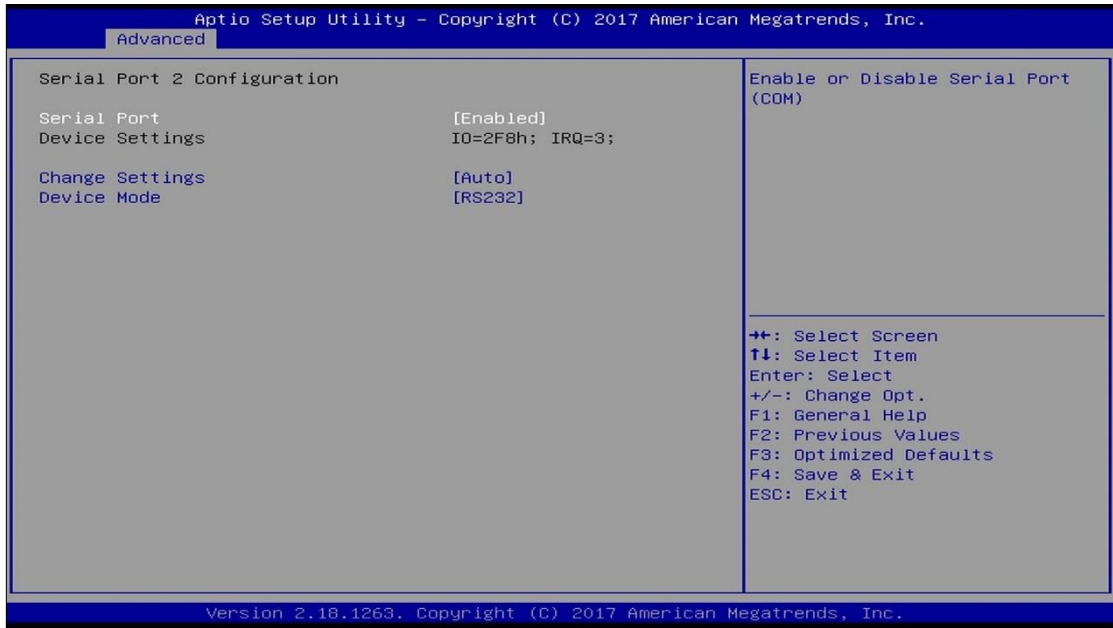

BIOS Setting	Description
Serial Port	Enables / Disables the serial port.
Change Settings	Selects an optimal settings for Super I/O device. Options: <ul style="list-style-type: none"> <li>• Auto</li> <li>• IO = 2F8h; IRQ = 3</li> <li>• IO = 3F8h; IRQ = 3, 4, 5, 6, 7, 9, 10, 11, 12</li> <li>• IO = 2F8h; IRQ = 3, 4, 5, 6, 7, 9, 10, 11, 12</li> <li>• IO = 3E8h; IRQ = 3, 4, 5, 6, 7, 9, 10, 11, 12</li> <li>• IO = 2E8h; IRQ = 3, 4, 5, 6, 7, 9, 10, 11, 12</li> </ul>
Device Mode Select	Changes the serial port mode to RS-232 / 422 / 485. Options: <ul style="list-style-type: none"> <li>• RS232</li> <li>• RS485 TX Low Active</li> <li>• RS485 with Termination TX Low Active</li> <li>• RS422</li> <li>• RS422 with Termination</li> </ul>

### 4.4.7.3. Serial Port 3 Configuration

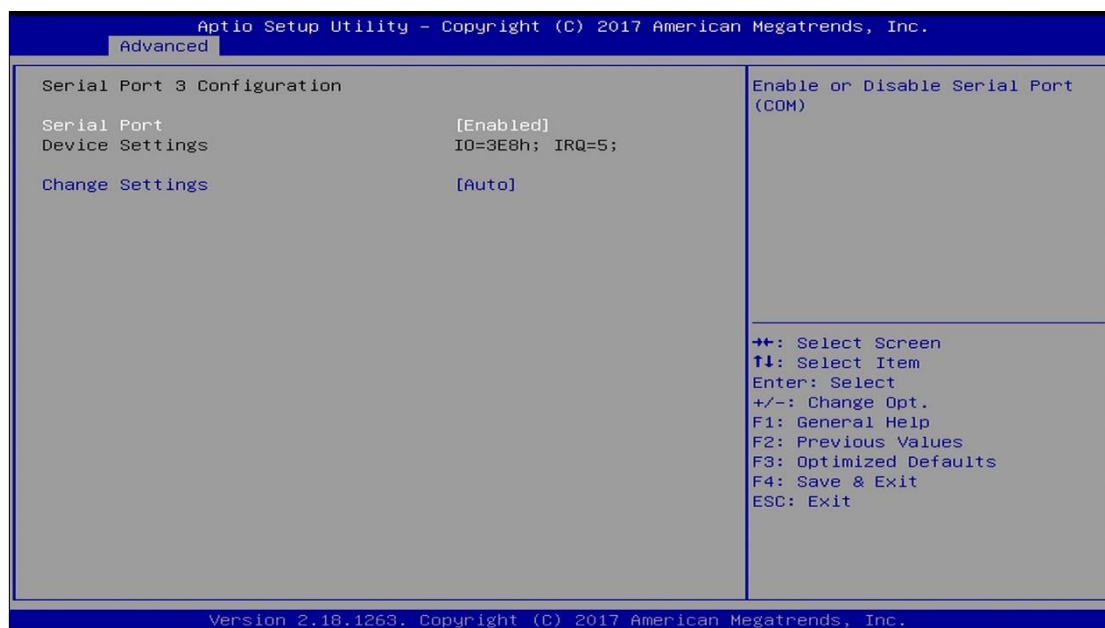

BIOS Setting	Description
Serial Port	Enables / Disables the serial port.
Change Settings	<p>Selects an optimal settings for Super I/O device.</p> <p>Options:</p> <ul style="list-style-type: none"> <li>• Auto</li> <li>• IO = 3E8h; IRQ = 7</li> <li>• IO = 3E8h; IRQ = 3, 4, 5, 6, 7, 9, 10, 11, 12</li> <li>• IO = 2E8h; IRQ = 3, 4, 5, 6, 7, 9, 10, 11, 12</li> <li>• IO = 2F0h; IRQ = 3, 4, 5, 6, 7, 9, 10, 11, 12</li> <li>• IO = 2E0h; IRQ = 3, 4, 5, 6, 7, 9, 10, 11, 12</li> </ul>

**4.4.7.4. Serial Port 4 Configuration**

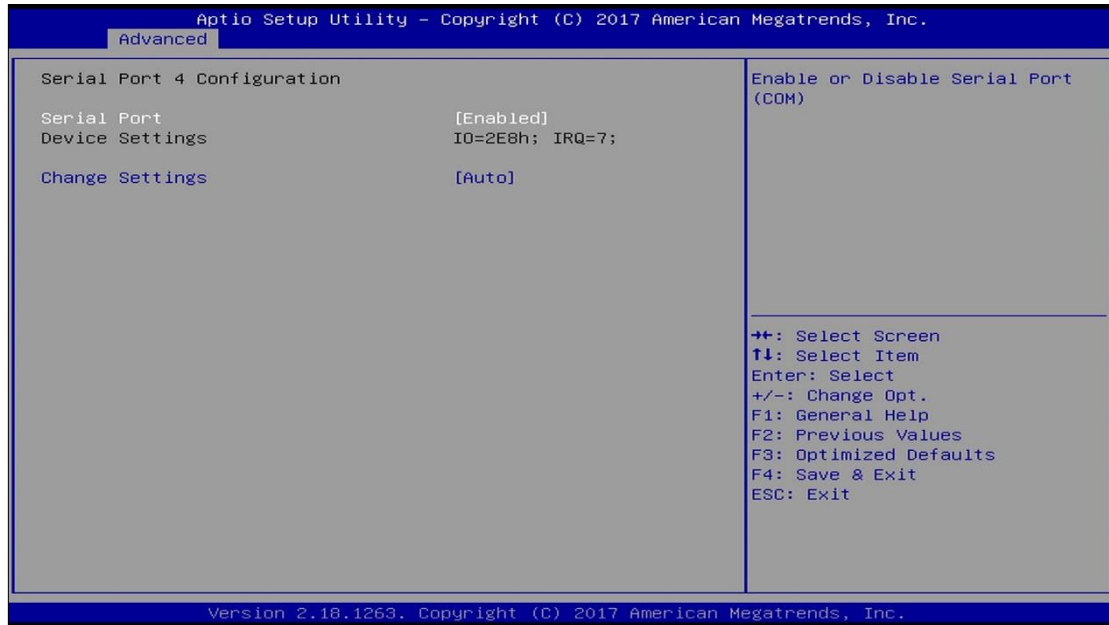

BIOS Setting	Description
Serial Port	Enables / Disables the serial port.
Change Settings	<p>Selects an optimal settings for Super I/O device.</p> <p>Options:</p> <ul style="list-style-type: none"> <li>• Auto</li> <li>• IO = 2E8h; IRQ = 7</li> <li>• IO = 3E8h; IRQ = 3, 4, 5, 6, 7, 9, 10, 11, 12</li> <li>• IO = 2E8h; IRQ = 3, 4, 5, 6, 7, 9, 10, 11, 12</li> <li>• IO = 2F0h; IRQ = 3, 4, 5, 6, 7, 9, 10, 11, 12</li> <li>• IO = 2E0h; IRQ = 3, 4, 5, 6, 7, 9, 10, 11, 12</li> </ul>

### 4.4.7.5. Serial Port 5 Configuration

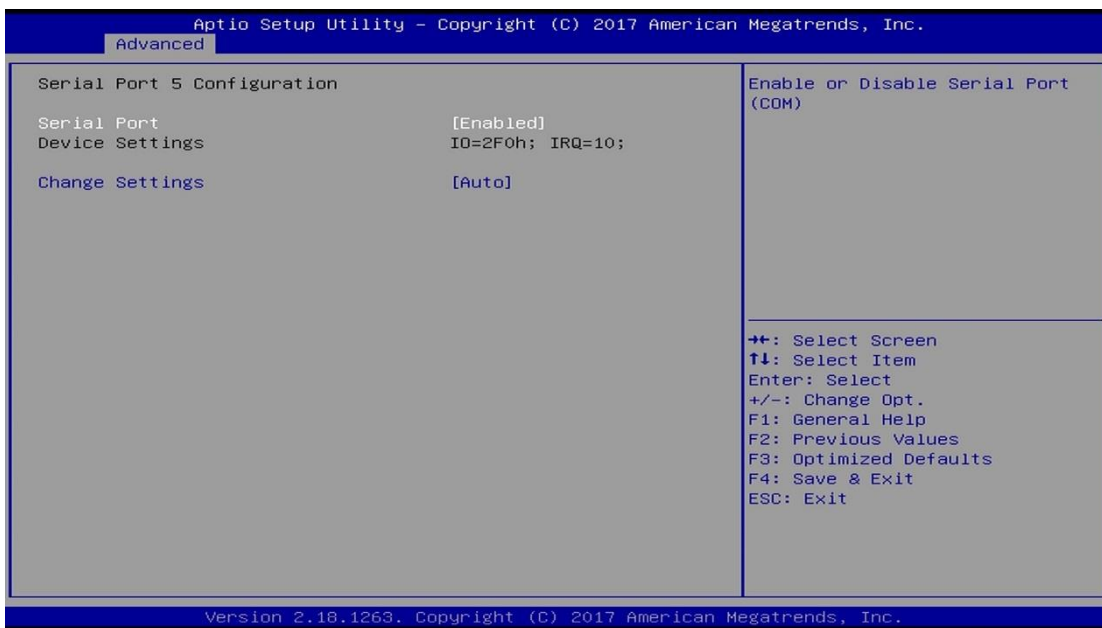

BIOS Setting	Description
Serial Port	Enables / Disables the serial port.
Change Settings	<p>Selects an optimal settings for Super I/O device.</p> <p>Options:</p> <ul style="list-style-type: none"> <li>• Auto</li> <li>• IO = 2E0h; IRQ = 7</li> <li>• IO = 3E8h; IRQ = 3, 4, 5, 6, 7, 9, 10, 11, 12</li> <li>• IO = 2E8h; IRQ = 3, 4, 5, 6, 7, 9, 10, 11, 12</li> <li>• IO = 2F0h; IRQ = 3, 4, 5, 6, 7, 9, 10, 11, 12</li> <li>• IO = 2E0h; IRQ = 3, 4, 5, 6, 7, 9, 10, 11, 12</li> </ul>

**4.4.7.6. Serial Port 6 Configuration**

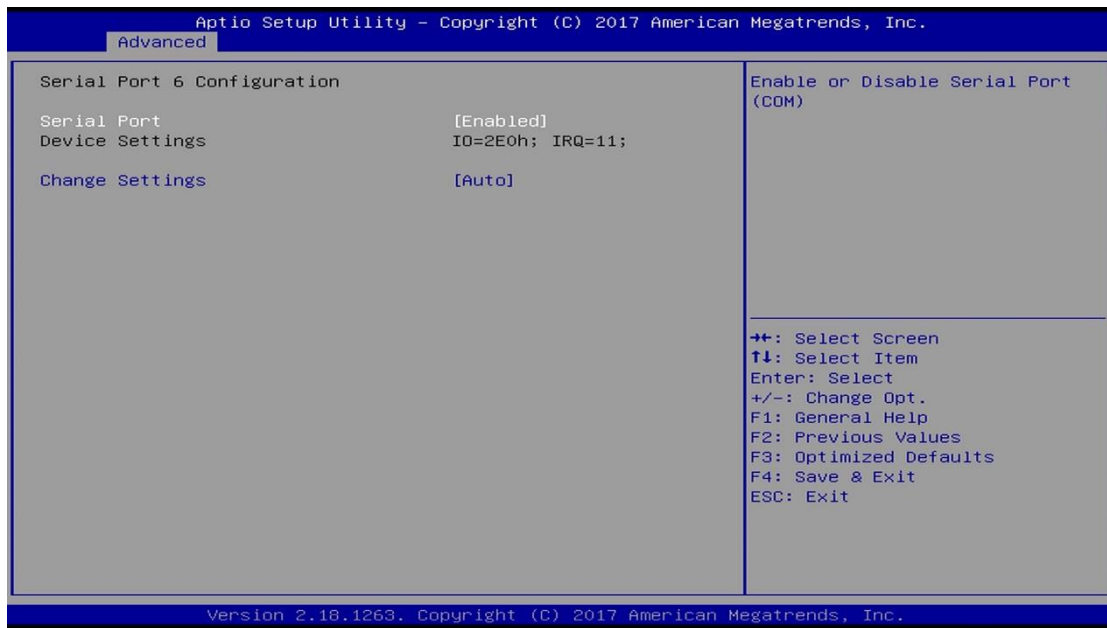

BIOS Setting	Description
Serial Port	Enables / Disables the serial port.
Change Settings	Selects an optimal settings for Super I/O device. Options: <ul style="list-style-type: none"> <li>• Auto</li> <li>• IO = 2F0h; IRQ = 7</li> <li>• IO = 3E8h; IRQ = 3, 4, 5, 6, 7, 9, 10, 11, 12</li> <li>• IO = 2E8h; IRQ = 3, 4, 5, 6, 7, 9, 10, 11, 12</li> <li>• IO = 2F0h; IRQ = 3, 4, 5, 6, 7, 9, 10, 11, 12</li> <li>• IO = 2E0h; IRQ = 3, 4, 5, 6, 7, 9, 10, 11, 12</li> </ul>

### 4.4.8 Fintek Super I/O Hardware Monitor

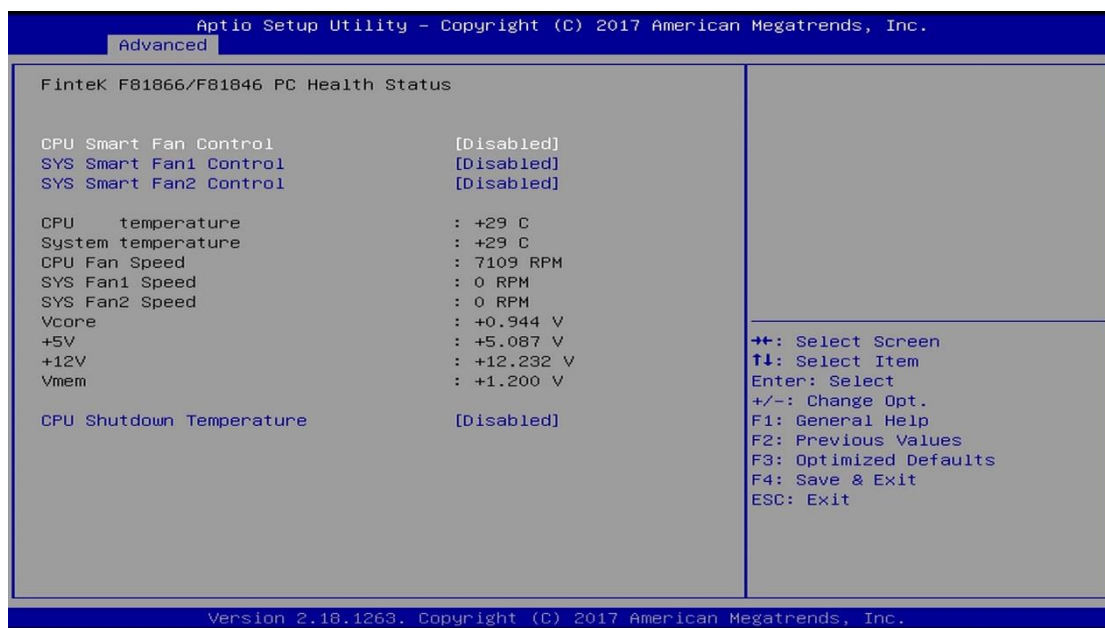

BIOS Setting	Description
CPU Smart Fan Control	Enables / Disables the CPU smart fan feature. Options: Disabled / 50 °C / 60 °C / 70 °C / 80 °C
System Smart Fan Control	Enables / Disables the system smart fan feature. Options: Disabled / 50 °C / 60 °C / 70 °C / 80 °C
Temperatures / Voltages	These fields are the parameters of the hardware monitoring function feature of the motherboard. The values are read-only values as monitored by the system and show the PC health status.
CPU Shutdown Temperature	Options: Disabled / 70 °C / 75 °C / 80 °C / 85 °C / 90 °C / 95 °C

### 4.4.9 CSM Configuration

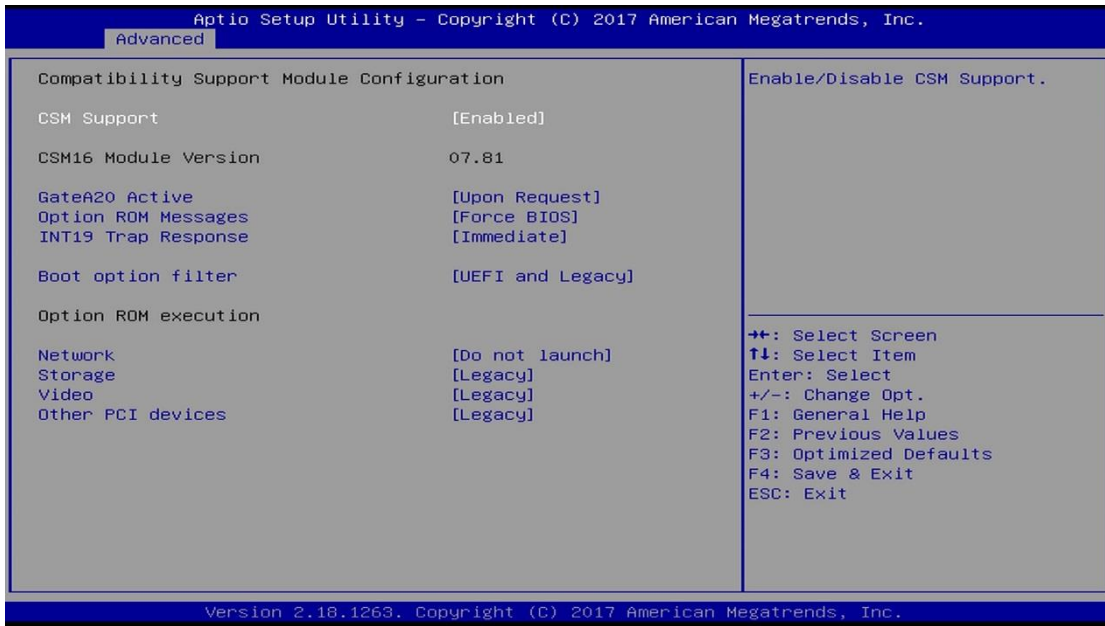

BIOS Setting	Description
EIST	Enables / Disables Intel SpeedStep.
CSM Support	Enables / Disables CSM support.
GateA20 Active	<ul style="list-style-type: none"> <li>Upon Request disables GA20 when using BIOS services.</li> <li>Always cannot disable GA20, but is useful when any RT code is executed above 1 MB.</li> </ul>
Option ROM Messages	Sets display mode for Option ROM. Options: Force BIOS, Keep Current
INT19 Trap Response	Sets how BIOS reacts on INT19 trap by Option ROM. <ul style="list-style-type: none"> <li>Immediate executes the trap right away.</li> <li>Postponed executes the trap during legacy boot.</li> </ul>
Boot option filter	Controls the priority of Legacy and UEFI ROMs. Options: UEFI and Legacy / Legacy only / UEFI only
Network	Controls the execution of UEFI and Legacy PXE OpROM. Options: Do not launch / Legacy

BIOS Setting	Description
Storage	Controls the execution of UEFI and Legacy Storage OpROM. Options: Do not lanuch / UEFI / Legacy
Video	Controls the execution of UEFI and Legacy Video OpROM. Options: Do not lanuch / UEFI / Legacy
Other PCI devices	Determines OpROM execution policy for devices other than network, storage or video. Options: Do not lanuch / UEFI / Legacy

### 4.4.10 NVMe Configuration

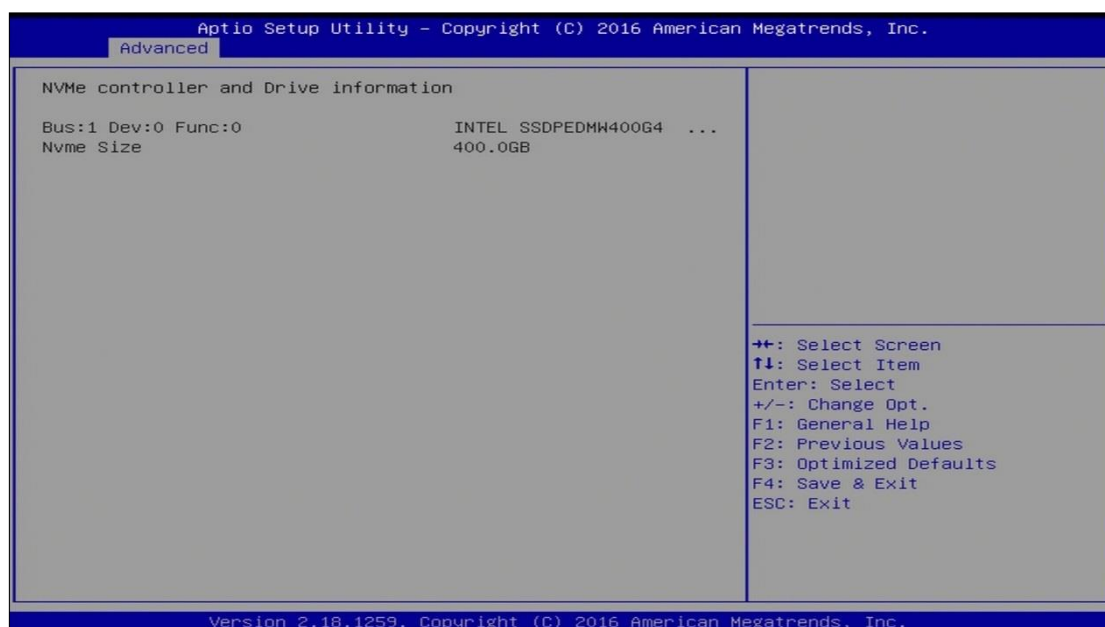

### 4.4.11 USB Configuration

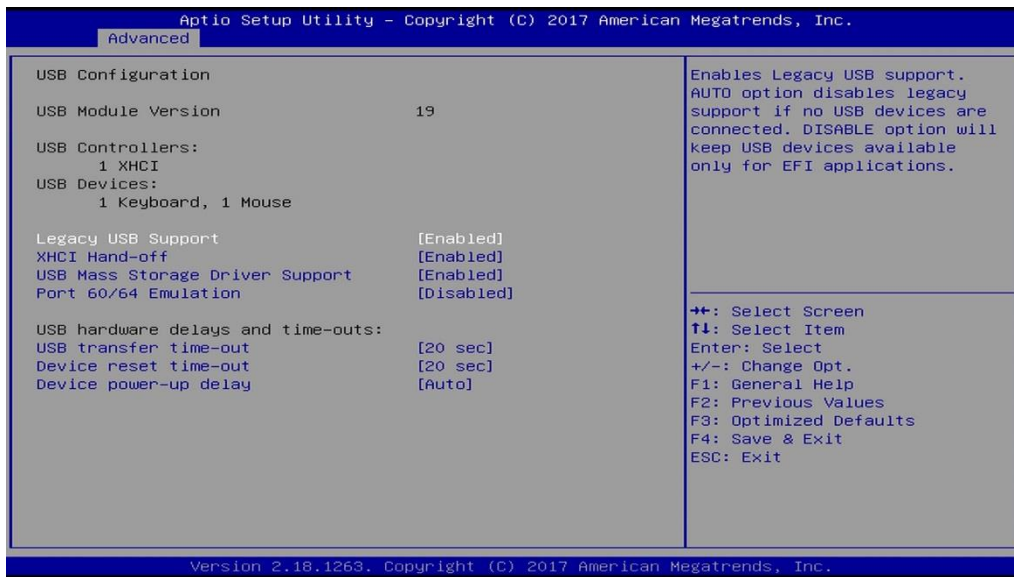

BIOS Setting	Description
Legacy USB Support	Enables Legacy USB support. <ul style="list-style-type: none"> <li>• Auto disables legacy support if there is no USB device connected.</li> <li>• Disable keeps USB devices available only for EFI applications.</li> </ul>
XHCI Hand-off	This is a workaround for OSES without XHCI hand-off support. The XHCI ownership change should be claimed by XHCI driver.
USB Mass Storage Driver Support	Enables / Disables the support for USB mass storage driver.
Port 60/64 Emulation	Enables / Disables I/O port 60h/64h emulation support. This should be enabled for the complete USB keyboard legacy support for non-USB aware OSES.
USB Transfer time-out	The time-out value for control, bulk, and Interrupt transfers. Options: 1 sec / 5 sec / 10 sec / 20 sec
Device reset time-out	Seconds of delaying execution of start unit command to USB mass storage device. Options: 10 sec / 20 sec / 30 sec / 40 sec
Device power-up delay	The maximum time the device will take before it properly reports itself to the Host Controller. Auto uses default value for a Root port it is 100ms. But for a Hub port, the delay is taken from Hub descriptor. Options: Auto / Manual

## 4.5 Chipset Settings



BIOS Setting	Description
System Agent (SA) Configuration	System Agent (SA) parameters
PCH-IO Configuration	PCH parameters

### 4.5.1 System Agent (SA) Configuration

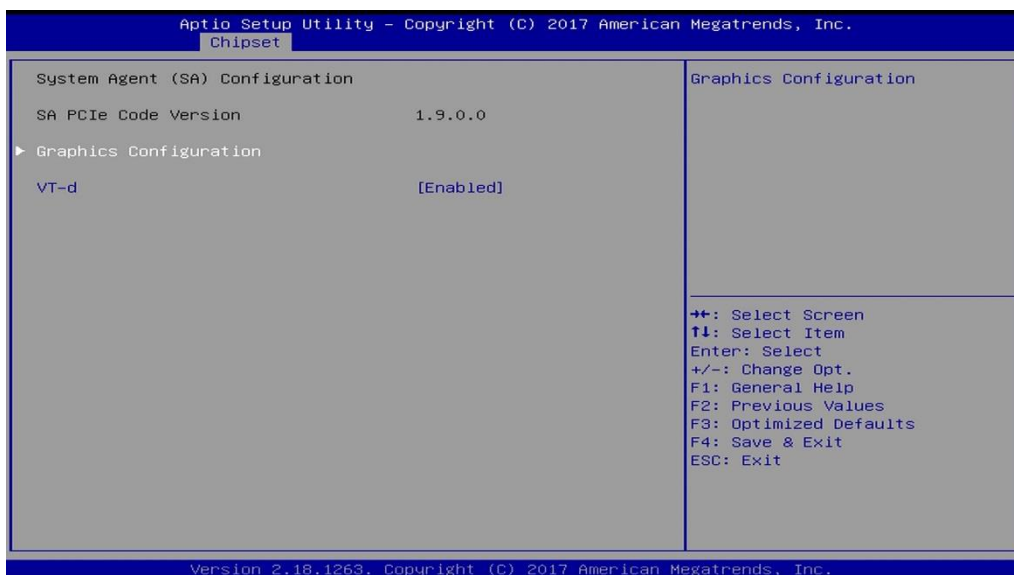

BIOS Setting	Description
Graphics Configuration	Configures the graphics settings.
VT-d	Checks if VT-d function on MCH is supported.

**4.5.1.1. Graphics Configuration**



BIOS Setting	Description
Skip Scanning of External Gfx Card	If enabled, it will not scan for external Gfx Card on PEG and PCH PCIe ports.
External Gfx Card Primary Display Configuration	Configures the external Gfx card primary display. <ul style="list-style-type: none"> <li>• Primary PEG: Selects the primary PEG (options: Auto / PEG11 / PEG12).</li> <li>• Primary PCIe: Selects the primary PCIe (options: Auto / PCIe1 ~ PCIe18)</li> </ul>
Internal Graphics	Keep IGFX enabled based on the setup options. Options: Auto / Disabled / Enabled
GTT Size	Sets the GTT size as 2 MB, 4 MB, or 8 MB.
Aperture Size	Sets the aperture size as 128 MB / 256 MB / 512 MB / 1024 MB / 2048 MB. Note: Above 4 GB MMIO BIOS assignment is automatically enabled when selecting 2048 MB aperture. To use this feature, disable CSM support.
DVMT Pre-Allocated	Sets DVMT 5.0 pre-allocated (fixed) graphics memory size used by the internal graphics device. Options: 0M / 32M / 64M / 4M / 8M / 12M / 16M / 20M / 24M / 28M / 32M/F7 / 36M / 40M / 44M / 48M / 52M / 56M / 60M
DVMT Total Gfx Mem	Selects DVMT 5.0 total graphic memory size used by the internal graphics device. Options: 256M / 128M / MAX

## 4.5.2 PCH-IO Configuration

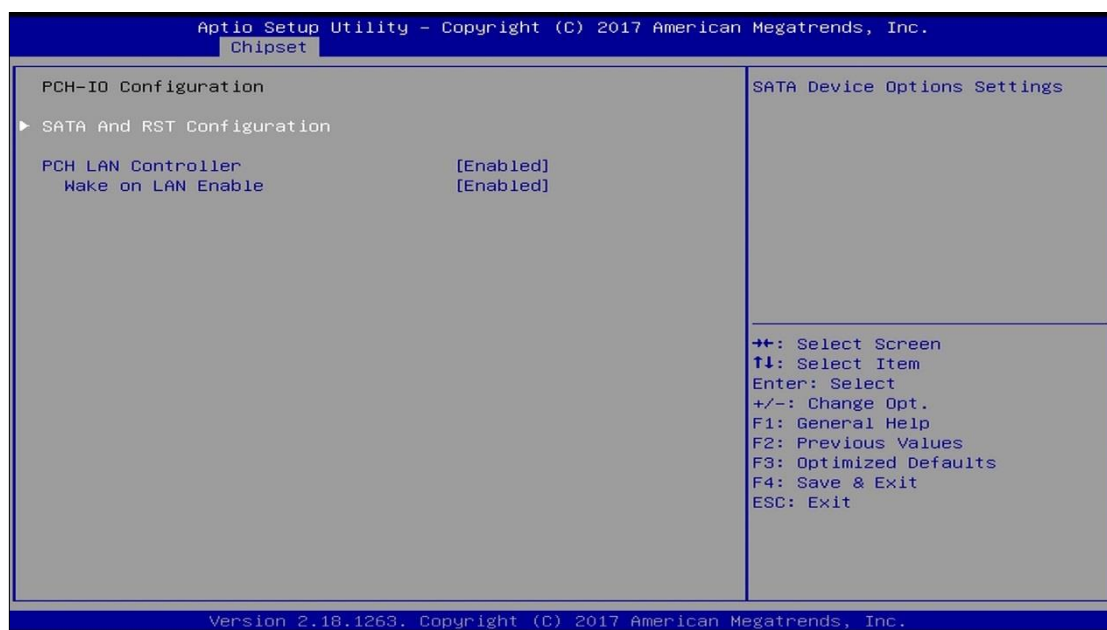

BIOS Setting	Description
SATA and RST Configuration	Configures SATA devices.
PCH LAN Controller	Enables / Disables the onboard NIC.
Wake on LAN Enable	Enables / Disables the integrated LAN to wake up the system.

### 4.5.2.1. SATA and RST Configuration

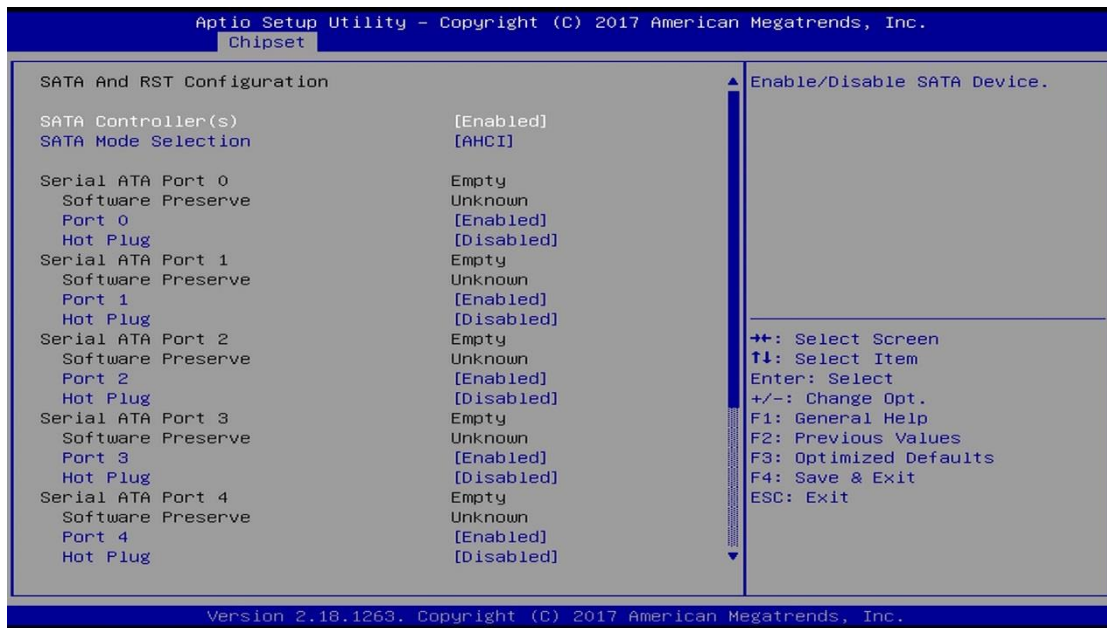

BIOS Setting	Description
SATA Controller(s)	Enables / Disables the SATA device.
SATA Mode Selection	Determines how SATA controller(s) operate. Options: AHCI / Intel RST Premium
Serial ATA Ports	Enables / Disables serial ports.
SATA Ports Hot Plug	Enables / Disables SATA Ports HotPlug.

## 4.6 Security Settings



BIOS Setting	Description
Administrator Password	Sets an administrator password for the setup utility.
User Password	Sets a user password.

## 4.7 Boot Settings

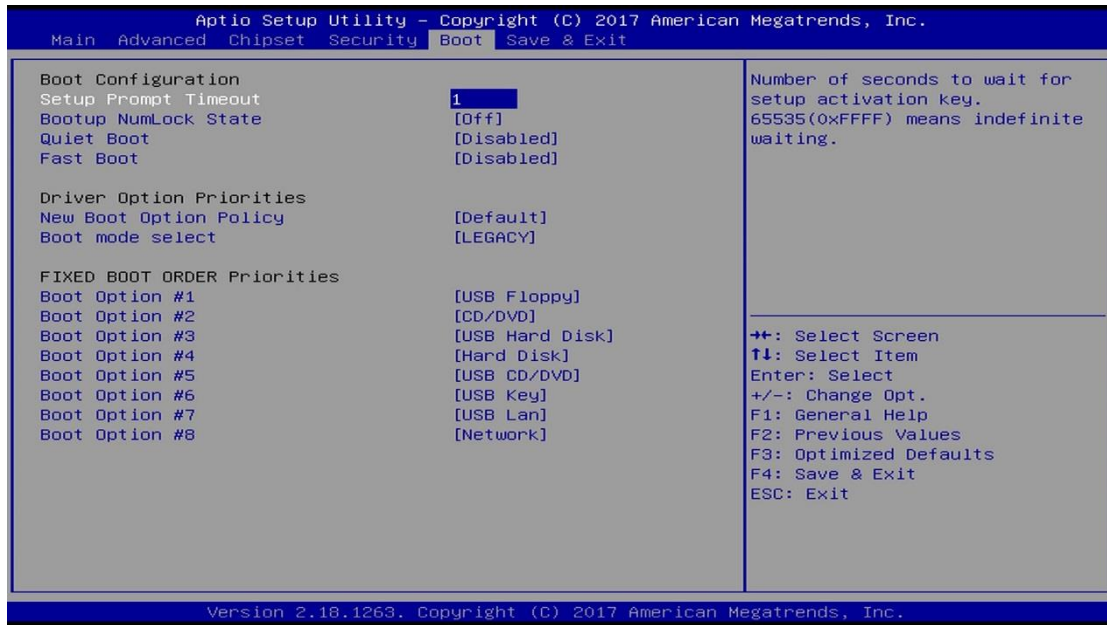

BIOS Setting	Description
Setup Prompt Timeout	Number of seconds to wait for setup activation key. 65535(0xFFFF) means indefinite waiting.
Bootup NumLock State	Selects the keyboard NumLock state.
Quiet Boot	Enables / Disables Quiet Boot option.
Fast Boot	Enables / Disables boot with initialization of a minimal set of devices required to launch active boot option. Has no effect for BBS boot options.
New Boot Option Policy	Controls the placement of newly detected UEFI boot option.
Boot mode select	Selects a Boot mode, Legacy / UEFI.
Boot Option Priorities	Sets the system boot order.

## 4.8 Save & Exit Settings

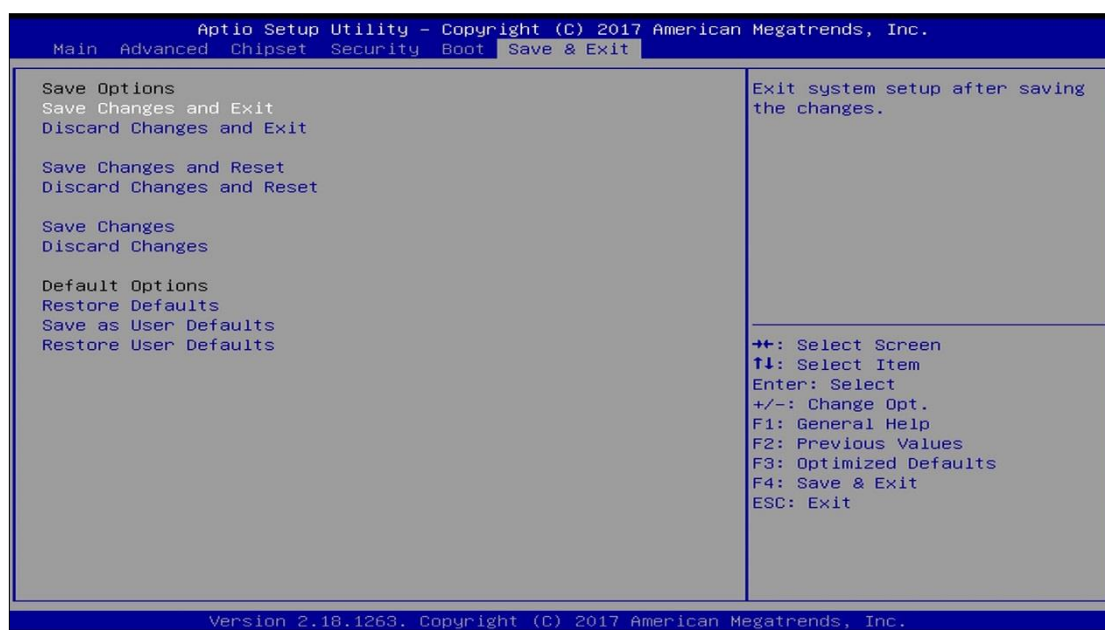

BIOS Setting	Description
Save Changes and Exit	Exits system setup after saving the changes.
Discard Changes and Exit	Exits system setup without saving any changes.
Save Changes and Reset	Resets the system after saving the changes.
Discard Changes and Reset	Resets system setup without saving any changes.
Save Changes	Saves changes done so far to any of the setup options.
Discard Changes	Discards changes done so far to any of the setup options.
Restore Defaults	Restores / Loads defaults values for all the setup options.
Save as User Defaults	Saves the changes done so far as User Defaults.
Restore User Defaults	Restores the user defaults to all the setup options.

## Appendix

This section provides the mapping addresses of peripheral devices and the sample code of watchdog timer configuration.

- I/O Port Address Map
- Interrupt Request Lines (IRQ)
- Digital I/O Sample Code
- Watchdog Timer Configuration

## A. I/O Port Address Map

Each peripheral device in the system is assigned a set of I/O port addresses which also becomes the identity of the device. The following table lists the I/O port addresses used.

Address	Device Description
0x00000A00-0x00000A0F	Motherboard resources
0x00000A10-0x00000A1F	Motherboard resources
0x00000A20-0x00000A2F	Motherboard resources
0x0000002E-0x0000002F	Motherboard resources
0x0000004E-0x0000004F	Motherboard resources
0x00000061-0x00000061	Motherboard resources
0x00000063-0x00000063	Motherboard resources
0x00000065-0x00000065	Motherboard resources
0x00000067-0x00000067	Motherboard resources
0x00000070-0x00000070	Motherboard resources
0x00000070-0x00000070	System CMOS/real time clock
0x00000080-0x00000080	Motherboard resources
0x00000092-0x00000092	Motherboard resources
0x000000B2-0x000000B3	Motherboard resources
0x00000680-0x0000069F	Motherboard resources
0x0000FFFF-0x0000FFFF	Motherboard resources
0x0000FFFF-0x0000FFFF	Motherboard resources
0x0000FFFF-0x0000FFFF	Motherboard resources
0x00001800-0x000018FE	Motherboard resources
0x0000164E-0x0000164F	Motherboard resources
0x00000040-0x00000043	System timer
0x00000050-0x00000053	System timer
0x00000800-0x0000087F	Motherboard resources
0x0000F000-0x0000F03F	Intel(R) HD Graphics 630
0x000003B0-0x000003BB	Intel(R) HD Graphics 630
0x000003C0-0x000003DF	Intel(R) HD Graphics 630
0x0000F090-0x0000F097	Standard SATA AHCI Controller

Address	Device Description
0x0000F080-0x0000F083	Standard SATA AHCI Controller
0x0000F060-0x0000F07F	Standard SATA AHCI Controller
0x000003F8-0x000003FF	Communications Port (COM1)
0x000002F8-0x000002FF	Communications Port (COM2)
0x000003E8-0x000003EF	Communications Port (COM3)
0x000002E8-0x000002EF	Communications Port (COM4)
0x000002F0-0x000002F7	Communications Port (COM5)
0x000002E0-0x000002E7	Communications Port (COM6)
0x0000E000-0x0000EFFF	Intel(R) 100 Series/C230 Series Chipset Family PCI Express Root Port #3 - A112
0x00000000-0x00000CF7	PCI Express Root Complex
0x00000D00-0x0000FFFF	PCI Express Root Complex
0x00000020-0x00000021	Programmable interrupt controller
0x00000024-0x00000025	Programmable interrupt controller
0x00000028-0x00000029	Programmable interrupt controller
0x0000002C-0x0000002D	Programmable interrupt controller
0x00000030-0x00000031	Programmable interrupt controller
0x00000034-0x00000035	Programmable interrupt controller
0x00000038-0x00000039	Programmable interrupt controller
0x0000003C-0x0000003D	Programmable interrupt controller
0x000000A0-0x000000A1	Programmable interrupt controller
0x000000A4-0x000000A5	Programmable interrupt controller
0x000000A8-0x000000A9	Programmable interrupt controller
0x000000AC-0x000000AD	Programmable interrupt controller
0x000000B0-0x000000B1	Programmable interrupt controller
0x000000B4-0x000000B5	Programmable interrupt controller
0x000000B8-0x000000B9	Programmable interrupt controller
0x000000BC-0x000000BD	Programmable interrupt controller
0x000004D0-0x000004D1	Programmable interrupt controller
0x0000F0A0-0x0000F0A7	Intel(R) Active Management Technology - SOL (COM7)
0x00001854-0x00001857	Motherboard resources
0x0000FF00-0x0000FFFE	Motherboard resources

<b>Address</b>	<b>Device Description</b>
0x0000F040-0x0000F05F	Intel(R) 100 Series/C230 Series Chipset Family SMBus - A123
0x00000060-0x00000060	Standard PS/2 Keyboard
0x00000064-0x00000064	Standard PS/2 Keyboard
0x000000F0-0x000000F0	Numeric data processor

## B. Interrupt Request Lines (IRQ)

Peripheral devices use interrupt request lines to notify CPU for the service required. The following table shows the IRQ used by the devices on board.

Level	Function
IRQ 0	System timer
IRQ 1	Standard PS/2 Keyboard
IRQ 3	Communications Port (COM2)
IRQ 4	Communications Port (COM1)
IRQ 5	Communications Port (COM3)
IRQ 7	Communications Port (COM4)
IRQ 8	System CMOS/real time clock
IRQ 11	Communications Port (COM6)
IRQ 11	Intel(R) Xeon(R) E3 - 1200/1500 v5/6th Gen Intel(R) Core(TM) Gaussian Mixture Model - 1911
IRQ 11	Intel(R) 100 Series/C230 Series Chipset Family SMBus - A123
IRQ 11	Intel(R) 100 Series/C230 Series Chipset Family Thermal subsystem - A131
IRQ 12	Microsoft PS/2 Mouse
IRQ 13	Numeric data processor
IRQ 14	Motherboard resources
IRQ 16	High Definition Audio Controller
IRQ 19	Intel(R) Active Management Technology - SOL (COM7)
IRQ 54 ~ IRQ 204	Microsoft ACPI-Compliant System
IRQ 256 ~ IRQ 511	Microsoft ACPI-Compliant System
IRQ 4294967283	Intel(R) Management Engine Interface
IRQ 4294967284	Intel(R) I211 Gigabit Network Connection
IRQ 4294967285	Intel(R) I211 Gigabit Network Connection
IRQ 4294967286	Intel(R) I211 Gigabit Network Connection
IRQ 4294967287	Intel(R) I211 Gigabit Network Connection
IRQ 4294967288	Intel(R) I211 Gigabit Network Connection
IRQ 4294967289	Intel(R) I211 Gigabit Network Connection
IRQ 4294967291	Intel(R) HD Graphics 630

<b>Level</b>	<b>Function</b>
IRQ 4294967292	Intel(R) Ethernet Connection (2) I219-LM
IRQ 4294967293	Standard SATA AHCI Controller
IRQ 4294967294	Intel(R) 100 Series/C230 Series Chipset Family PCI Express Root Port #3 - A112

## C. Watchdog Timer Configuration

The Watchdog Timer (WDT) is used to generate a variety of output signals after a user programmable count. The WDT is suitable for the use in the prevention of system lock-up, such as when software becomes trapped in a deadlock. Under these sorts of circumstances, the timer will count to zero and the selected outputs will be driven.

Under normal circumstance, you will need to restart the WDT at regular intervals before the timer counts to zero.

### Sample Code:

```
//-----  
//  
// THIS CODE AND INFORMATION IS PROVIDED "AS IS" WITHOUT WARRANTY OF ANY  
// KIND, EITHER EXPRESSED OR IMPLIED, INCLUDING BUT NOT LIMITED TO THE  
// IMPLIED WARRANTIES OF MERCHANTABILITY AND/OR FITNESS FOR A PARTICULAR  
// PURPOSE.  
//  
//-----  
#include <dos.h>  
#include <conio.h>  
#include <stdio.h>  
#include <stdlib.h>  
#include "F81866.H"  
//-----  
int main (int argc, char *argv[]);  
void EnableWDT(int);  
void DisableWDT(void);  
//-----  
int main (int argc, char *argv[])  
{  
    unsigned char bBuf;  
    unsigned char bTime;  
    char **endptr;  
  
    char SIO;  
  
    printf("Fintek 81866 watch dog program\n");  
    SIO = Init_F81866();  
    if (SIO == 0)  
    {  
        printf("Can not detect Fintek 81866, program abort.\n");  
        return(1);  
    }/if (SIO == 0)  
  
    if (argc != 2)  
    {  
        printf(" Parameter incorrect!!\n");  
        return (1);  
    }  
  
    bTime = strtol (argv[1], endptr, 10);  
    printf("System will reset after %d seconds\n", bTime);  
}
```

```

    if (bTime)
    {   EnableWDT(bTime); }
    else
    {   DisableWDT();   }
    return 0;
}
//-----
void EnableWDT(int interval)
{
    unsigned char bBuf;

    bBuf = Get_F81866_Reg(0x2B);
    bBuf &= (~0x20);
    Set_F81866_Reg(0x2B, bBuf); //Enable WDTO

    Set_F81866_LD(0x07); //switch to logic device 7
    Set_F81866_Reg(0x30, 0x01); //enable timer

    bBuf = Get_F81866_Reg(0xF5);
    bBuf &= (~0x0F);
    bBuf |= 0x52;
    Set_F81866_Reg(0xF5, bBuf); //count mode is second

    Set_F81866_Reg(0xF6, interval); //set timer

    bBuf = Get_F81866_Reg(0xFA);
    bBuf |= 0x01;
    Set_F81866_Reg(0xFA, bBuf); //enable WDTO output

    bBuf = Get_F81866_Reg(0xF5);
    bBuf |= 0x20;
    Set_F81866_Reg(0xF5, bBuf); //start counting
}
//-----
void DisableWDT(void)
{
    unsigned char bBuf;

    Set_F81866_LD(0x07); //switch to logic device 7

    bBuf = Get_F81866_Reg(0xFA);
    bBuf &= ~0x01;
    Set_F81866_Reg(0xFA, bBuf); //disable WDTO output

    bBuf = Get_F81866_Reg(0xF5);
    bBuf &= ~0x20;
    bBuf |= 0x40;
    Set_F81866_Reg(0xF5, bBuf); //disable WDT
}
//-----

//-----
//
// THIS CODE AND INFORMATION IS PROVIDED "AS IS" WITHOUT WARRANTY OF ANY
// KIND, EITHER EXPRESSED OR IMPLIED, INCLUDING BUT NOT LIMITED TO THE
// IMPLIED WARRANTIES OF MERCHANTABILITY AND/OR FITNESS FOR A PARTICULAR
// PURPOSE.
//
//-----

```

# iBASE

```
#include "F81866.H"
#include <dos.h>
//-----
unsigned int F81866_BASE;
void Unlock_F81866 (void);
void Lock_F81866 (void);
//-----
unsigned int Init_F81866(void)
{
    unsigned int result;
    unsigned char ucDid;

    F81866_BASE = 0x4E;
    result = F81866_BASE;

    ucDid = Get_F81866_Reg(0x20);
    if (ucDid == 0x07) //Fintek 81866
    { goto Init_Finish; }

    F81866_BASE = 0x2E;
    result = F81866_BASE;

    ucDid = Get_F81866_Reg(0x20);
    if (ucDid == 0x07) //Fintek 81866
    { goto Init_Finish; }

    F81866_BASE = 0x00;
    result = F81866_BASE;

Init_Finish:
    return (result);
}
//-----
void Unlock_F81866 (void)
{
    outportb(F81866_INDEX_PORT, F81866_UNLOCK);
    outportb(F81866_INDEX_PORT, F81866_UNLOCK);
}
//-----
void Lock_F81866 (void)
{
    outportb(F81866_INDEX_PORT, F81866_LOCK);
}
//-----
void Set_F81866_LD( unsigned char LD)
{
    Unlock_F81866();
    outportb(F81866_INDEX_PORT, F81866_REG_LD);
    outportb(F81866_DATA_PORT, LD);
    Lock_F81866();
}
//-----
void Set_F81866_Reg( unsigned char REG, unsigned char DATA)
{
    Unlock_F81866();
    outportb(F81866_INDEX_PORT, REG);
    outportb(F81866_DATA_PORT, DATA);
    Lock_F81866();
}
//-----
```

```

unsigned char Get_F81866_Reg(unsigned char REG)
{
    unsigned char Result;
    Unlock_F81866();
    outportb(F81866_INDEX_PORT, REG);
    Result = inportb(F81866_DATA_PORT);
    Lock_F81866();
    return Result;
}
//-----

//-----
//
// THIS CODE AND INFORMATION IS PROVIDED "AS IS" WITHOUT WARRANTY OF ANY
// KIND, EITHER EXPRESSED OR IMPLIED, INCLUDING BUT NOT LIMITED TO THE
// IMPLIED WARRANTIES OF MERCHANTABILITY AND/OR FITNESS FOR A PARTICULAR
// PURPOSE.
//
//-----
#ifndef F81866_H
#define F81866_H 1
//-----
#define F81866_INDEX_PORT (F81866_BASE)
#define F81866_DATA_PORT (F81866_BASE+1)
//-----
#define F81866_REG_LD0x07
//-----
#define F81866_UNLOCK 0x87
#define F81866_LOCK 0xAA
//-----
unsigned int Init_F81866(void);
void Set_F81866_LD( unsigned char);
void Set_F81866_Reg( unsigned char,
unsigned char); unsigned char
Get_F81866_Reg( unsigned char);
//-----
#endif // F81866_H

```