

# **IPPC1003-PC**

## **Expandable Panel PC**

### **User's Manual**

Version 1.0



## **Copyright**

© 2025 IBASE Technology, Inc. All rights reserved.

No part of this publication may be reproduced, copied, stored in a retrieval system, translated into any language or transmitted in any form or by any means, electronic, mechanical, photocopying, or otherwise, without the prior written consent of IBASE Technology, Inc. (hereinafter referred to as "IBASE").

## **Disclaimer**

IBASE reserves the right to make changes and improvements to the products described in this document without prior notice. Every effort has been made to ensure the information in the document is correct; however, IBASE does not guarantee this document is error-free. IBASE assumes no liability for incidental or consequential damages arising from misapplication or inability to use the product or the information contained herein, nor for any infringements of rights of third parties, which may result from its use.

## **Trademarks**

All the trademarks, registrations and brands mentioned herein are used for identification purposes only and may be trademarks and/or registered trademarks of their respective owners.

## Compliance

### CE

This product has passed CE tests for environmental specifications and limits. This product is in accordance with the directives of the European Union (EU). If users modify and/or install other devices in this equipment, the CE conformity declaration may no longer apply.

### FCC

This product has been tested and found to comply with the limits for a Class B device, pursuant to Part 15 of the FCC Rules. These limits are designed to provide reasonable protection against harmful interference in a residential installation. This equipment generates, uses and can radiate radio frequency energy and, if not installed and used in accordance with manufacturer's instructions, may cause harmful interference to radio communications.

### WEEE



This product must not be disposed of as normal household waste, in accordance with the EU directive for waste electrical and electronic equipment (WEEE - 2012/19/EU). Instead, it should be disposed of by returning it to a municipal recycling collection point. Check local regulations for disposal of electronic products.

### Green IBASE



This product complies with RoHS 2 restrictions, which prohibit the use of certain hazardous substances in electrical and electronic equipment. The following substances must not exceed the specified concentrations:

- Hexavalent chromium: 1,000 ppm
- Poly-brominated biphenyls (PBBs): 1,000 ppm
- Poly-brominated diphenyl ethers (PBDEs): 1,000 ppm
- Cadmium: 100 ppm
- Mercury: 1,000 ppm
- Lead: 1,000 ppm
- Bis(2-ethylhexyl) phthalate (DEHP): 1,000 ppm
- Butyl benzyl phthalate (BBP): 1,000 ppm
- Dibutyl phthalate (DBP): 1,000 ppm
- Diisobutyl phthalate (DIBP): 1,000 ppm

## Important Safety Information

Carefully read the precautions before using the device.

### Environmental conditions:

- Lay the device horizontally on a stable and solid surface in case the device may fall, causing serious damage.
- Make sure you leave plenty of space around the device for ventilation.
- Use this product in environments with ambient temperatures 0°C ~ 45°C.

### Care for your iBASE products:

- Before cleaning the device, turn it off and unplug all cables such as power in case a small amount of electrical current may still flow.
- Use neutral cleaning agents or diluted alcohol to clean the device chassis with a cloth. Then wipe the chassis with a dry cloth.
- Vacuum the dust with a computer vacuum cleaner to prevent the air vent or slots from being clogged.



## WARNING

### Attention during use:

- Do not use this product near water.
- Do not spill water or any other liquids on your device.
- Do not place heavy objects on the top of the device.
- Operate this device from the type of power indicated on the marking label. If you are not sure of the type of power available, consult your distributor or local power company.
- Do not walk on the power cord or allow anything to rest on it.
- If you use an extension cord, make sure that the total ampere rating of the product plugged into the extension cord does not exceed its limits.

### Avoid Disassembly

Do not disassemble, repair or make any modification to the device. Disassembly, modification, or any attempt at repair could generate hazards and cause damage to the device, even bodily injury or property damage, and will void any warranty.



## CAUTION

Replace only with the same or equivalent type recommended by the manufacturer. Dispose of used batteries according to the manufacturer's instructions.

## Warranty Policy

- **IBASE standard products:**

24-month warranty from the date of shipment. If the date of shipment cannot be ascertained, the product serial numbers can be used to determine the approximate shipping date.

- **3<sup>rd</sup>-party parts:**

12-month warranty from delivery for the 3<sup>rd</sup>-party parts that are not manufactured by IBASE, such as CPU, memory, HDD, power adapter, panel and touchscreen.

\* PRODUCTS, HOWEVER, THAT FAIL DUE TO MISUSE, ACCIDENT, IMPROPER INSTALLATION OR UNAUTHORIZED REPAIR SHALL BE TREATED AS OUT OF WARRANTY AND CUSTOMERS SHALL BE BILLED FOR REPAIR AND SHIPPING CHARGES.

## Technical Support & Services

1. Visit the IBASE website at [www.ibase.com.tw](http://www.ibase.com.tw) to find the latest information about the product.
2. If you need any further assistance from your distributor or sales representative, prepare the following information of your product and elaborate upon the problem.
  - Product model name
  - Product serial number
  - Detailed description of the problem
  - The error messages in text or in screenshots if there is any
  - The arrangement of the peripherals
  - Software in use (such as OS and application software, including the version numbers)
3. If repair service is required, please go to the IBASE website and apply for an RMA number to fill out the RMA application form.

# Table of Contents

---

Compliance.....	iii
Important Safety Information .....	iv
<b>WARNING</b> .....	<b>iv</b>
<b>CAUTION</b> .....	<b>v</b>
Warranty Policy.....	v
Technical Support & Services .....	v
<b>Chapter 1    General Information.....</b>	<b>1</b>
1.1    Introduction .....	2
1.2    Features.....	2
1.3    Packing List .....	2
1.4    Specifications.....	3
1.5    Product View.....	4
1.6    Dimensions .....	5
<b>Chapter 2    Hardware Configuration .....</b>	<b>6</b>
2.1    Installations.....	13
2.1.1    Rear Cover Disassembly .....	13
2.1.2    Memory Replacement.....	14
2.1.3    SSD / HDD Replacement .....	14
2.1.4    Mini-PCIe Installation.....	15
2.1.5    VESA Mounting Installation .....	15
2.1.6    Pinout for COM1 and COM2.....	16
<b>Chapter 3    Jumper Setting, BIOS Setting and Driver Installation for IPPC1003-PC .....</b>	<b>17</b>

# Chapter 1

## General Information

The information provided in this chapter includes:

- Features
- Packing List
- Specifications
- Product View
- Dimensions

## 1.1 Introduction

The IPPC1003-PC is a 10.4" touch panel PC, ideal for industrial and factory automation applications. It is powered by an Intel® Celeron® J1900 processor and features IP65-rated ingress protection for the front bezel.



## 1.2 Features

- Resistive touch screen
- Cost-effective model
- Low-power consumption
- IP65-rated front bezel
- PCIe (x1) and PCI expansion

## 1.3 Packing List

Your product package should include the items listed below.

- System: 1
- Power adapter: 1
- Power cord: 1
- Long screws (for mounting the device on wall): 6 (M4\*20)
- Short screws (for mounting the triangle brackets onto the rear side of the device): 12
- Mounting Triangle Bracket: 6

## 1.4 Specifications

Model No.		IPPC1003-PC
<b>Display &amp; Touch Screen</b>	Display Size	10.4" TFT-LCD
	Max. Resolution	1024 x 768
	Luminance (cd/m <sup>2</sup> )	350
	Contrast	700:1
	Max. Color	16.7M
	View Angle (H°/V°)	150/150
	Backlight Lifetime(hrs)	30,000
	Touch Type	Projected capacitive
	Touch Interface	USB
	Light Transmission (%)	85
	Point of touch	Up to 2
<b>I/O Interface</b>	USB 3.0	1
	USB 2.0	1
	RS-232/422/485 Selectable in BIOS	1
	RS-232	1
	LAN	1x GbE
	Additional Graphics	DP and VGA
	Audio	None
	Digital I/O	None
	Power Connector	Power jack
	Power Button	Rock switch
	<b>Mechanical</b>	Dimensions (mm)
Net Weight (kgs)		2.2
<b>System</b>	Processor	Intel® Atom® Processor E3815 1.46GHz
	Memory	1x DDR3L SO-DIMM, up to 4GB, default 2GB
	Thermal Design	Fanless
	Membrane Controls	None
	Built-in Speaker/MIC	None
<b>Expansion</b>	Internal Expansion Bus	1x Mini PCI-E(x1) [full/half-size]2x Mini PCI-E(x1) [half-size]
	Expansion Slot	None
	Wireless	Optional
<b>StorageSpace</b>	HDD	1x 2.5" SATA
	Removable	None
<b>Power</b>	Power Input Range	12V DC
<b>Construction</b>	Chassis Material	SGCC with aluminum heat-sink, Black
	Color (Front/Back)	Black/Black
	IP Rating	IP65 rated front bezel
	Mounting	Panel mount and VESA 75x75mm
<b>Environmental</b>	Operating Temperature	-20°C ~ 50°C
	Storage Temperature	-30°C ~ 80°C
	Storage Humidity	10%~90% (non-condensing)
	Certification	CE/FCC class B and LVD
	Supported Operating Systems	Windows 8 32/64-bit, Windows Embedded7 Pro 64-bit, WES7 64-bit

All specifications are subject to change without prior notice.

## 1.5 Product View

### Front View

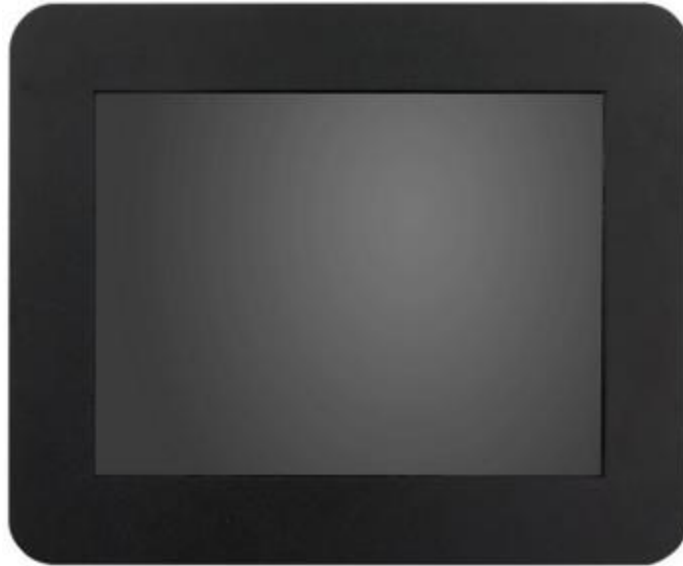

### Oblique View



### Oblique View



IPP1003-PC

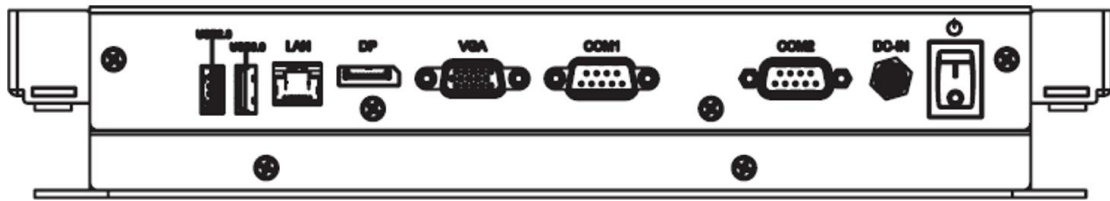

### 1.6 Dimensions

Unit: mm

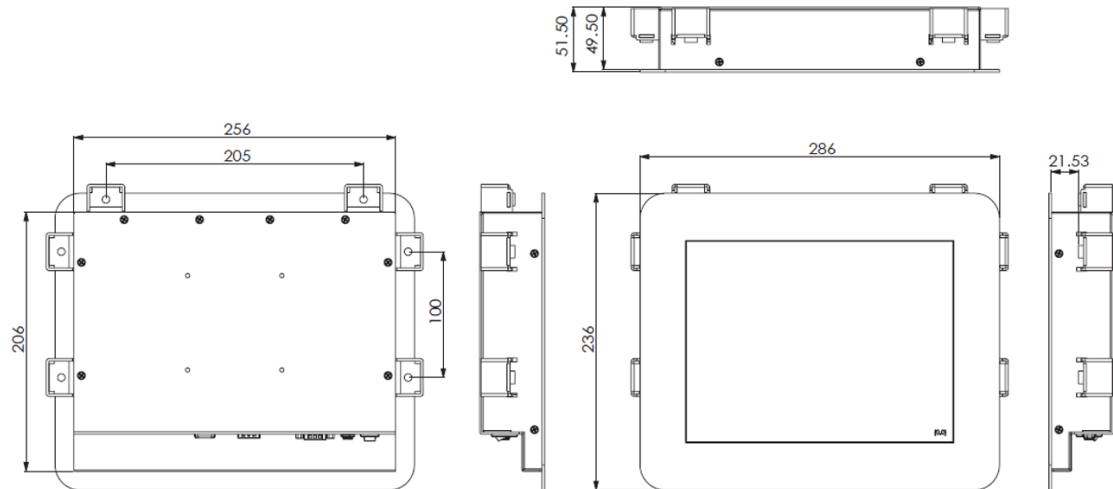

## Chapter 2

# Hardware Configuration

The information provided in this chapter includes:

- Installations
- Information of jumpers and connectors

## 2.1 Installations

---

Avoid device disassembly: Disassembly, modification, or any attempt at repair could generate hazards and cause damage to the device, injury, or property damage, and will void any warranty. If you need to make any changes to the device, be sure to unplug the power cord of the device and have qualified engineers or technicians do the disassembly or installation.

---

### 2.1.1 Rear Cover Disassembly

In case you need to remove the rear cover to install a memory module, a mini-PCIe card or any expansion card, unscrew the 12 screws as shown below to remove the rear cover.

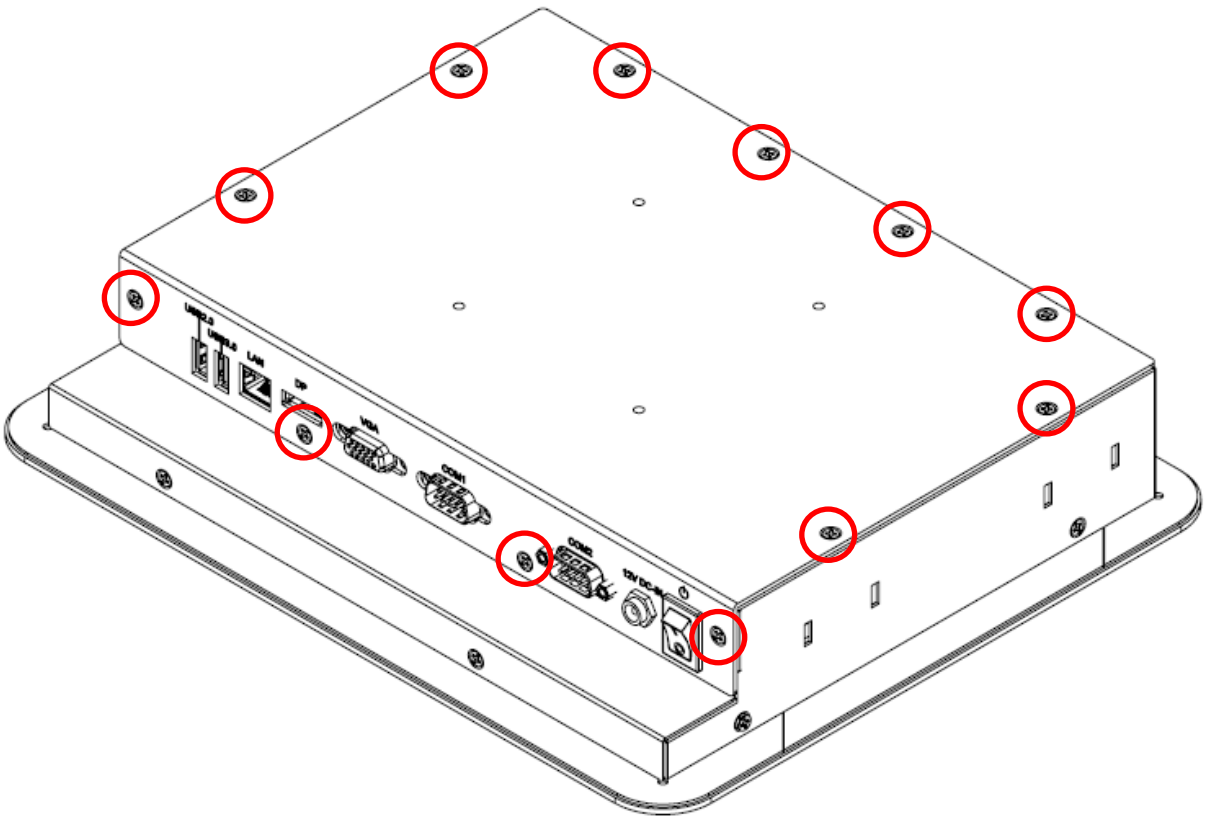

## 2.1.2 Memory Replacement

To replace or install memory modules, perform the following steps after removing the system rear cover.

1. Locate the memory slot and align the key of the memory module with that on the memory slot.
2. Insert the module slantwise and gently push the module straight down until the clips of the slot close to hold the module in place when the module touches the bottom of the slot.

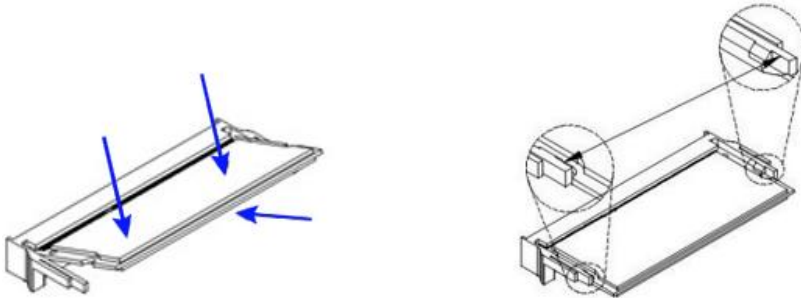

To remove the module, press the clips outwards with both hands.

## 2.1.3 SSD / HDD Replacement

1. After removing the rear cover, unscrew the following 4 screws to remove the SSD/HDD tray.

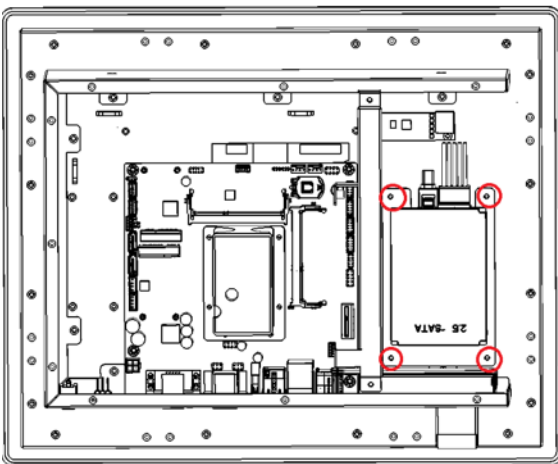

2. Unplug the cables of the SSD / HDD. Unscrew the 4 screws on the bottom of the tray to release the SSD / HDD and replace it with a new one.
3. Secure the new SSD/ HDD to the tray, fix it onto the motherboard, and connect the cables.

### 2.1.4 Mini-PCle Installation

To replace or install a mini-PCle card, perform the following steps after removing the rear cover.

1. Locate the mini-PCle slot, align the key of the card to the interface, and insert the card slantwise.

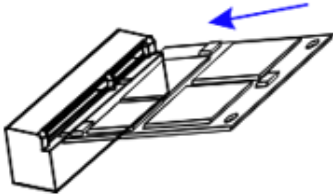

2. Push the card down and fix it with the supplied flat head screw.

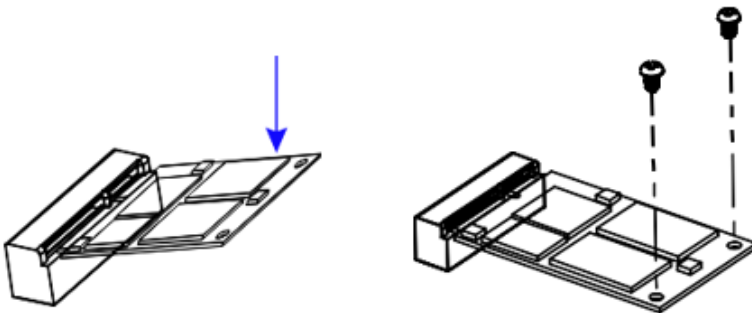

### 2.1.5 VESA Mounting Installation

You will need to prepare the VESA mount bracket in advance. Tighten 4 VESA screws as shown below to mount the device onto your VESA bracket.

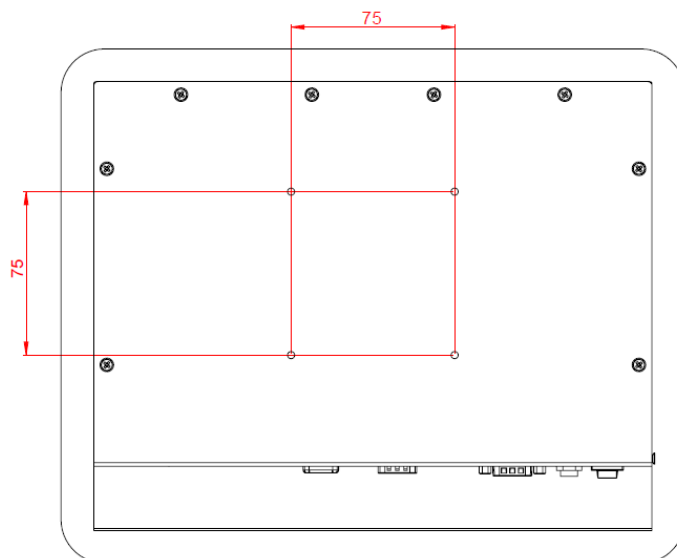

## 2.1.6 Pinout for COM1 and COM2

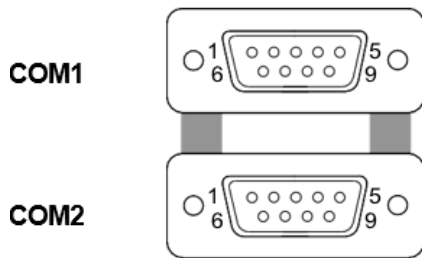

### COM1 RS232/422/485 Port

COM 1 features jumperless selection for RS-232/422/485 and configurable in BIOS.

Pin	Signal Name	Pin	Signal Name
1	DCD, Data carrier detect	6	DSR, Data set ready
2	RXD, Receive data	7	RTS, Request to send
3	TXD, Transmit data	8	CTS, Clear to send
4	DTR, Data terminal ready	9	RI, Ring indicator
5	Ground		

Pin	Signal Name		
	RS-232	RS-422	RS-485
1	DCD	TX-	DATA-
2	RX	TX+	DATA+
3	TX	RX+	NC
4	DTR	RX-	NC
5	Ground	Ground	Ground
6	DSR	NC	NC
7	RTS	NC	NC
8	CTS	NC	NC
9	RI	NC	NC

### COM2 RS-232 Port

Pin	Signal Name	Pin	Signal Name
1	DCD, Data carrier detect	6	DSR, Data set ready
2	RXD, Receive data	7	RTS, Request to send
3	TXD, Transmit data	8	CTS, Clear to send
4	DTR, Data terminal ready	9	RI, Ring indicator
5	Ground		

## Chapter 3

# Jumper Setting, BIOS Setting and Driver Installation for IPPC1003-PC

IPPC1003-PC uses the IB898 motherboard. Please see the related links below:

### **Drivers Download**

[https://drive.google.com/drive/folders/1Ri6utAdUrarotmQYH-IAPRyMGQG0O\\_ND](https://drive.google.com/drive/folders/1Ri6utAdUrarotmQYH-IAPRyMGQG0O_ND)

### **Motherboard Manual**

<https://drive.google.com/drive/folders/1d8xjMYjJKxDekmxVLKF4I8aF76PzslvU>

### **Motherboard Datasheet**

[https://www.ibase.com.tw/english/download/Embedded\\_Computing/Disk-Size\\_SBCs/IB898\\_Datasheet.pdf](https://www.ibase.com.tw/english/download/Embedded_Computing/Disk-Size_SBCs/IB898_Datasheet.pdf)

This page is intentionally left blank.