

IP418

ATX COM Express Type 6 Carrier Board

User's Manual

Version 1.0
(Feb. 2019)



Copyright

© 2019 IBASE Technology, Inc. All rights reserved.

No part of this publication may be reproduced, copied, stored in a retrieval system, translated into any language or transmitted in any form or by any means, electronic, mechanical, photocopying, or otherwise, without the prior written consent of IBASE Technology, Inc. (hereinafter referred to as “IBASE”).

Disclaimer

IBASE reserves the right to make changes and improvements to the products described in this document without prior notice. Every effort has been made to ensure the information in the document is correct; however, IBASE does not guarantee this document is error-free.

IBASE assumes no liability for incidental or consequential damages arising from misapplication or inability to use the product or the information contained herein, nor for any infringements of rights of third parties, which may result from its use.

Trademarks

All the trademarks, registrations and brands mentioned herein are used for identification purposes only and may be trademarks and/or registered trademarks of their respective owners.

Compliance



In a domestic environment, this product may cause radio interference in which case users may be required to take adequate measures.



This product has been tested and found to comply with the limits for a Class A device, pursuant to Part 15 of the FCC Rules. These limits are designed to provide reasonable protection against harmful interference in a residential installation. This equipment generates, uses and can radiate radio frequency energy and, if not installed and used in accordance with manufacturer's instructions, may cause harmful interference to radio communications.

WEEE



This product must not be disposed of as normal household waste, in accordance with the EU directive of for waste electrical and electronic equipment (WEEE - 2012/19/EU). Instead, it should be disposed of by returning it to a municipal recycling collection point. Check local regulations for disposal of electronic products.

Green IBASE



This product is compliant with the current RoHS restrictions and prohibits use of the following substances in concentrations exceeding 0.1% by weight (1000 ppm) except for cadmium, limited to 0.01% by weight (100 ppm).

- Lead (Pb)
- Mercury (Hg)
- Cadmium (Cd)
- Hexavalent chromium (Cr6+)
- Polybrominated biphenyls (PBB)
- Polybrominated diphenyl ether (PBDE)

Important Safety Information

Carefully read the precautions before using the board.

Environmental conditions:

- Use this product in environments with ambient temperatures between -20°C and 70°C.
- Do not leave this product in an environment where the storage temperature may be below -40° C or above 90° C.

Care for your iBASE products:

- Before cleaning the PCB, unplug all cables and remove the battery.
- Clean the PCB with a circuit board cleaner, degreaser, or use cotton swabs and alcohol.
- Vacuum the dust with a computer vacuum cleaner to prevent the fan from being clogged.



WARNING

Attention during use:

- Do not use this product near water.
- Do not spill water or any other liquids on this product.
- Do not place heavy objects on the top of this product.

Anti-static precautions

- Wear an anti-static wrist strap to avoid electrostatic discharge.
- Place the PCB on an anti-static kit or mat.
- Ground yourself by touching grounded bit of metal. When you touch a grounded metal, your body is discharged and all the current flows to ground rather than through sensitive components.



CAUTION

Danger of explosion if the internal lithium-ion battery is replaced by an incorrect type. Replace only with the same or equivalent type recommended by the manufacturer.

Warranty Policy

- **IBASE standard products:**

24-month (2-year) warranty from the date of shipment. If the date of shipment cannot be ascertained, the product serial numbers can be used to determine the approximate shipping date.

- **3rd-party parts:**

12-month (1-year) warranty from delivery for the 3rd-party parts that are not manufactured by IBASE, such as CPU, CPU cooler, memory, storage devices, power adapter, panel and touchscreen.

- * PRODUCTS, HOWEVER, THAT FAIL DUE TO MISUSE, ACCIDENT, IMPROPER INSTALLATION OR UNAUTHORIZED REPAIR SHALL BE TREATED AS OUT OF WARRANTY AND CUSTOMERS SHALL BE BILLED FOR REPAIR AND SHIPPING CHARGES.

Technical Support & Services

1. Visit the IBASE website at www.ibase.com.tw to find the latest information about the product.
2. If you need any further assistance from your distributor or sales representative, prepare the following information of your product and elaborate upon the problem.
 - Product model name
 - Product serial number
 - Detailed description of the problem
 - The error messages in text or in screenshots if there is any
 - The arrangement of the peripherals
 - Software in use (such as OS and application software, including the version numbers)
3. If repair service is required, you can download the RMA form at <http://www.ibase.com.tw/english/Supports/RMAService/>. Fill out the form and contact your distributor or sales representative.

Table of Contents

Compliance	iii
Important Safety Information	iv
Warranty Policy	v
Technical Support & Services	v
Chapter 1 General Information	1
1.1 Introduction	2
1.2 Features	2
1.3 Specifications	3
1.4 Overview	5
1.5 Dimensions	6
Chapter 2 Hardware Configuration	8
2.1 Setting the Jumpers	9
2.2.1 How to Set Jumpers	9
2.2 Connector Locations on IP418	10
2.3 Jumpers Quick Reference	11
2.3.1 LVDS Panel Power (JP1)	11
2.3.2 eDP / LVDS Selection (JP2)	12
2.3.3 LVDS Backlight Power Selection (JP4)	12
2.3.4 eDP Panel Power (JP5)	13
2.3.5 eDP Panel Brightness Selection (JP3)	13
2.3.6 BIOS Boot-Up Selection (JP6)	14
2.4 Connectors Quick Reference	15
2.4.1 COM1 & COM2 RS-232 Ports (CN6)	16
2.4.2 SATA Power Connector (J2, J3)	16
2.4.3 VGA Port (VGA1)	17
2.4.4 DVI-D Port (J6)	18
2.4.5 Parallel Port (LPT1)	19
2.4.6 Digital I/O Connector (J9)	20
2.4.7 Panel Inverter Power Connector (J7)	20
2.4.8 LVDS Connector (CN11, CN12)	21
2.4.9 USB 2.0 Connector (J10)	22
2.4.10 COM3 & COM4 RX/TX Port (J11, J12)	22

2.4.11	System Function Connector (J13).....	23
2.4.12	Fan Power Connector (CPU_FAN1, SYS_FAN1).....	24
2.4.13	ATX 12V Power Connector (J14)	24
2.4.14	ATX Power Connector (J15).....	25
2.4.15	eDP Connector (CN13).....	26
Appendix		27
A.	Onboard Connector Types	28

This page is intentionally left blank.

Chapter 1

General Information

The information provided in this chapter includes:

- Features
- Specifications
- Board Overview
- Board Dimensions

1.1 Introduction

IP418 is a carrier board for ATX COM Express Type 6 CPU module; it is compatible with the ET976 COMe module and features expansion slots including PCIe (x1), PCIe (x16) and mPCIe and outputs video - HDMI and DP.

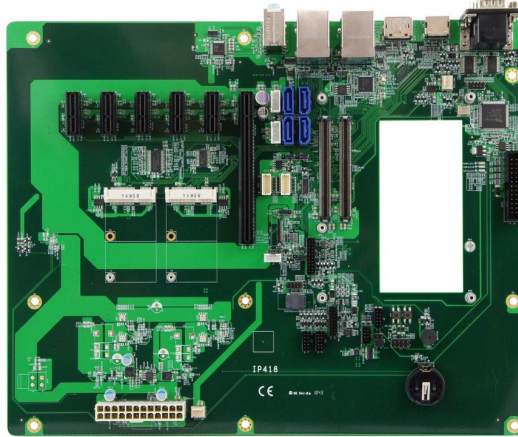

Photo of IP418

1.2 Features

- Supports 5 x PCIe (x1) and 1 x PCIe (x16)
- Data transmission and I/O ports: USB 3.0, USB 2.0, GbE LAN, DisplayPort, HDMI, audio jacks, serial COM ports
- On-board headers for serial ports and eDP / LVDS derived from the COMe module ET976

1.3 Specifications

Product Name	IP418
Form Factor	ATX COM Express Type 6 (R3.0) carrier board
Super I/O	Fintek F81964D-I
Digital I/O	4-In / 4-Out
Watchdog	Watchdog Timer 256 segments, 0, 1, 2...255 sec/min
Dimensions	305 x 244 mm (12" x 9.61")
RoHS	Yes
I/O Ports / Connectors	
Power Supply	DC-In 12V via an onboard 2x2 pin connector
Display	<ul style="list-style-type: none"> • 3 x DDI (1 x DisplayPort, 1 x HDMI, 1 x DVI-D) • 1 x 18/24-bit dual channel LVDS or 1 x eDP (Choose either one)
LAN	2 x RJ45 LAN (LAN 1: Derived from COMe module LAN 2: 1 x onboard Intel® I210IT)
USB	Derived from COMe module. <ul style="list-style-type: none"> • 4 x USB 2.0 (2 are edge I/O connectors, and 2 are on-board box-headers.) • 4 x USB 3.0 (edge I/O)
Parallel	1 x parallel port via an onboard header
Serial	4 x COM ports: <ul style="list-style-type: none"> • COM1: RS-232 (full-function) (edge I/O connector) • COM2: RS-232 (full-function) (edge I/O connector) • COM3 & COM4: RS-232 (TX and RX only) (from the COMe module, via an on-board box-header)

Serial ATA	Derived from COMe module. 4 x SATA III
Audio Jacks	Onboard Realtek ALC662 with 5.1 channel HD audio: 1 x Line-In, 1 x Line-Out, 1 x Mic-In
Battery for RTC/CMOS	1 x Lithium battery button cell for RTC of COMe module
Expansion Slots	<ul style="list-style-type: none">• 5 x PCIe (x1) slots• 1 x PCIe (x16) slot• 2 x Mini-PCIe slots
Environment	
Temperature	<ul style="list-style-type: none">• Operating: -40 ~ 85°C (-40 ~ -185°F)• Storage: -40 ~ 90 °C (-40 ~ 194°F)
Relative Humidity	10 ~ 90 % (non-condensing)

All specifications are subject to change without prior notice.

1.4 Overview

Top View

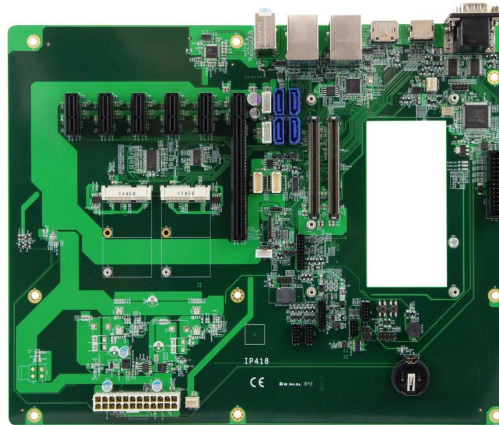

I/O View

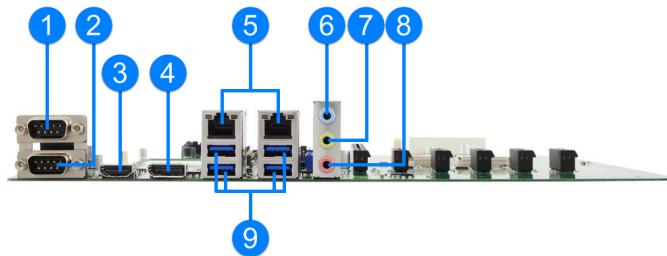

No.	Name	No.	Name
1	COM1 RS-232/422/485 Port	6	Audio Line-Out
2	COM2 RS-232 Port	7	Microphone Input
3	GbE LAN Port	8	USB 2.0 Ports
4	DVI-D Port	9	DisplayPort
5	Audio Line-In	10	USB 3.0 Port

* The photos above are for reference only. Some minor components may differ.

1.5 Dimensions

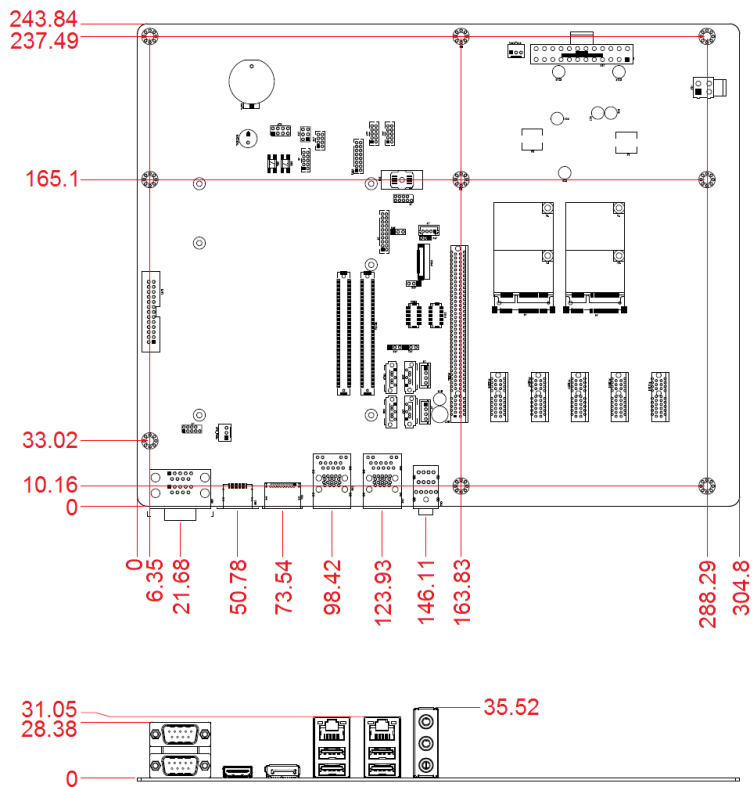

This page is intentionally left blank.

Chapter 2

Hardware Configuration

This section provides information on jumper settings and connectors on the IP419 in order to set up a workable system.

- Jumper and connector locations
- Jumper settings and information of connectors

2.1 Setting the Jumpers

Set up and configure your board by using jumpers for various settings and features according to your needs and applications. Contact your supplier if you have doubts about the best configuration for your use.

2.2.1 How to Set Jumpers

Jumpers are short-length conductors consisting of several metal pins with a non-conductive base mounted on the circuit board. Jumper caps are used to have the functions and features enabled or disabled. If a jumper has 3 pins, you can connect either PIN1 to PIN2 or PIN2 to PIN3 by shorting.

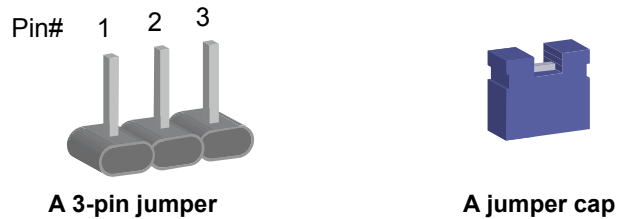

Refer to the illustration below to set jumpers.

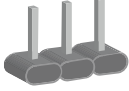
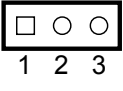
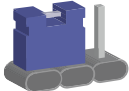
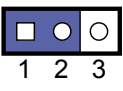
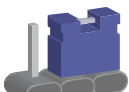
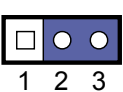
Pin closed	Oblique view	Schematic illustration
Open		
1-2		
2-3		

When two pins of a jumper are encased in a jumper cap, this jumper is **closed**, i.e. turned **On**.

When a jumper cap is removed from two jumper pins, this jumper is **open**, i.e. turned **Off**.

2.3 Jumpers Quick Reference

Function	Jumper	Page
LVDS Panel Power	JP1	11
eDP / LVDS Selection	JP2	12
LVDS Backlight Power Selection	JP4	12
eDP Panel Power	JP5	13
eDP Panel Brightness Selection	JP3	13
BIOS Boot-Up Selection	JP6	14

2.3.1 LVDS Panel Power (JP1)

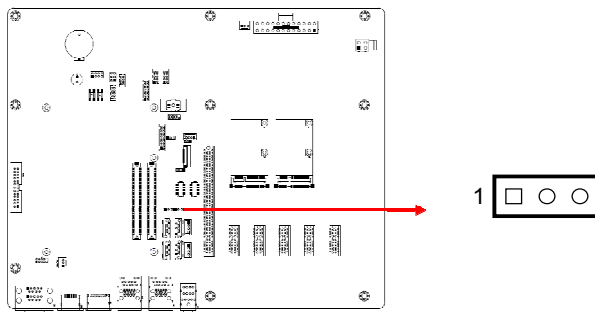

Function	Pin closed	Illustration
3.3V (default)	1-2	1
5V	2-3	1

2.3.2 eDP / LVDS Selection (JP2)

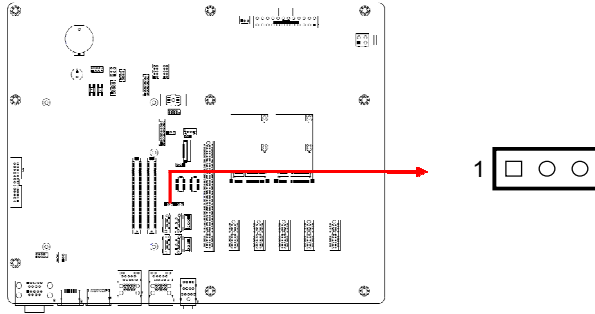

Function	Pin closed	Illustration
eDP (default)	1-2	1
LVDS	2-3	1

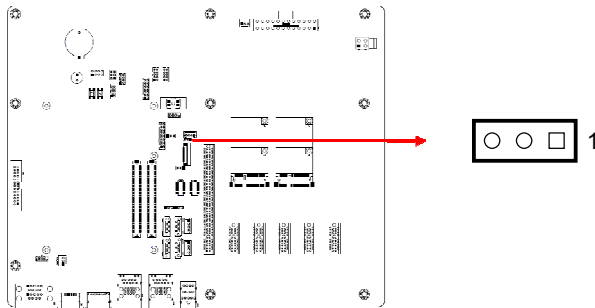

2.3.3 LVDS Backlight Power Selection (JP4)



Function	Pin closed	Illustration
3.3V (default)	1-2	1
5V	2-3	1

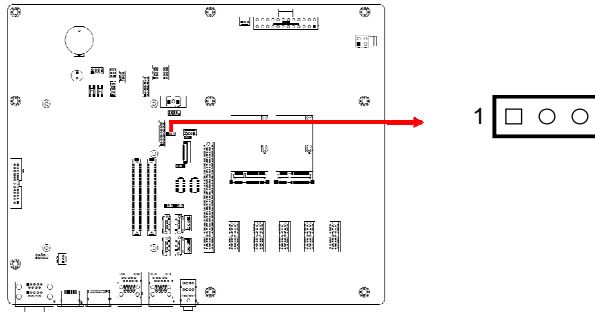

2.3.4 eDP Panel Power (JP5)

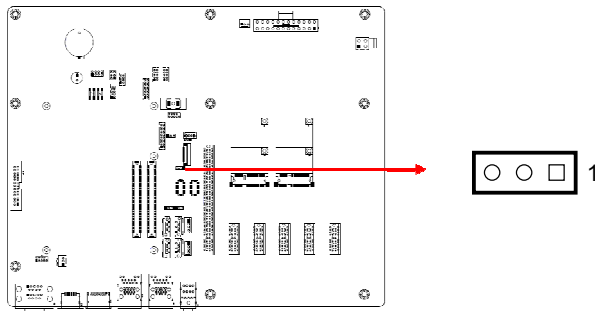

Function	Pin closed	Illustration
3.3V (default)	1-2	1 
5V	2-3	1 

2.3.5 eDP Panel Brightness Selection (JP3)



Function	Pin closed	Illustration
5V (default)	1-2	 1
12V	2-3	 1

2.3.6 BIOS Boot-Up Selection (JP6)

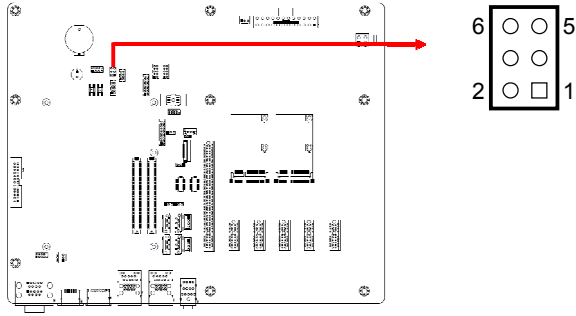

Function	Pin closed	Illustration
From COMe CPU module (default)	3-4, 5-6	
From IP418 carrier board	5-6	

2.4 Connectors Quick Reference

Function	Connector Name	Page
COM1 & COM2 RS-232 Ports	CN6	16
SATA Power Connector	J2, J3	16
VGA Port	VGA1	17
DVI-D Port	J6	18
Parallel Port	LPT1	19
Digital I/O Connector	J9	20
Panel Inverter Power Connector	J7	20
LVDS Connector	CN11 (Channel 2), CN12 (Channel 1)	21
USB 2.0 Connector	J10	22
COM3 & COM4 RX/TX Port	J12 (COM3), J11 (COM4)	22
System Function Connector	J13	23
Fan Power Connector	CPU_FAN1, SYS_FAN1	24
ATX 12V Power Connector ^[1]	J14	24
ATX Power Connector	J15	25
eDP Connector	CN13	26
Power Button	SW1	--
Reset Button	SW2	--
GbE LAN Port and USB 3.0 Ports	CN2, CN3	--
HDMI Port	CN5	--
Audio Connector	CN1	--
PCIe (x16) Slot	PCIE1X16	--
Mini-PCIe Slot	J4, J5	--
SATA III Connector	CN7, CN8, CN9, CN10	--
PCIe (x1) Slot	PCIEX1, PCIEX2, PCIEX3, PCIEX4, PCIEX5	--
COM Express Connector	RECS1, RECS2	--
Factory Use Only	J1, J8	--

[1] ATX 12V Power Connector (J14) is only available for IP418-DC.

2.4.1 COM1 & COM2 RS-232 Ports (CN6)

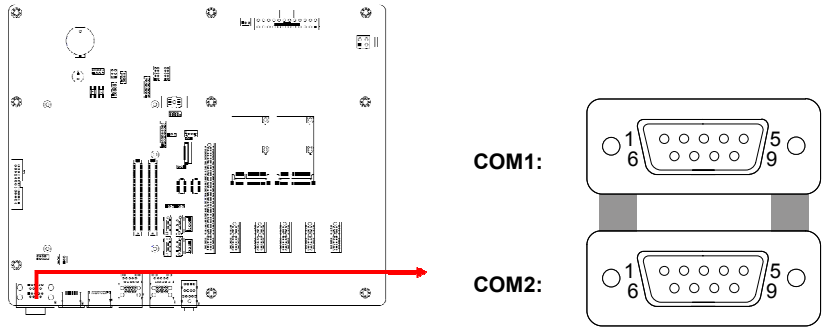

Pin	Signal Name	Pin	Signal Name
1	DCD, Data carrier detect	6	DSR, Data set ready
2	RXD, Receive data	7	RTS, Request to send
3	TXD, Transmit data	8	CTS, Clear to send
4	DTR, Data terminal ready	9	RI, Ring indicator
5	Ground		

2.4.2 SATA Power Connector (J2, J3)

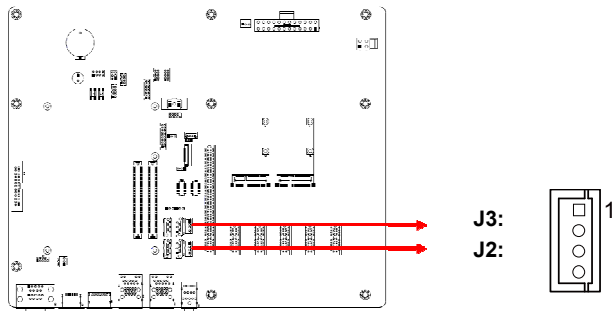

Pin	Signal Name	Pin	Signal Name
1	+5V	3	Ground
2	Ground	4	+12V

2.4.3 VGA Port (VGA1)

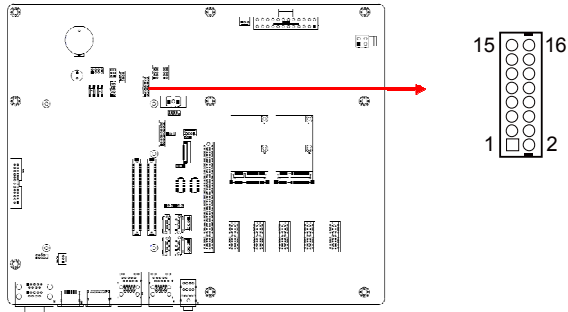

Pin	Signal Name	Pin	Signal Name
1	CRT1_RED	2	5V
3	CRT1_GREEN	4	Ground
5	CRT1_BLUE	6	NC
7	NC	8	CRT1_DDC_DATA_ISO
9	Ground	10	CRT1_HSYN_R
11	Ground	12	CRT1_VSYN_R
13	Ground	14	CRT1_DDC_CLK_ISO
15	Ground	16	NC

2.4.4 DVI-D Port (J6)

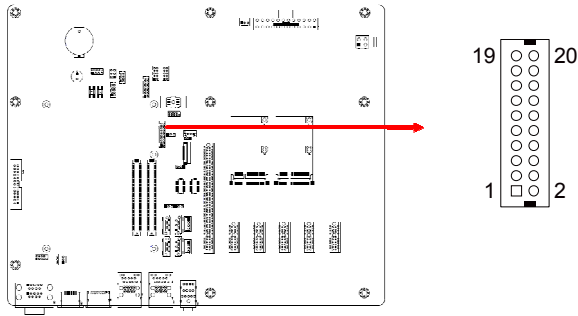

Pin	Signal Name	Pin	Signal Name
1	TDC1_B	2	TDC1#_B
3	Ground	4	Ground
5	TLC_B	6	TLC#_B
7	Ground	8	5V
9	HPDET_B	10	N.C.
11	TDC2_B	12	TDC2#_B
13	Ground	14	Ground
15	TDC0_B	16	TDC0#_B
17	N.C.	18	N.C.
19	SD_DDC_B	20	SC_DDC_B

2.4.5 Parallel Port (LPT1)

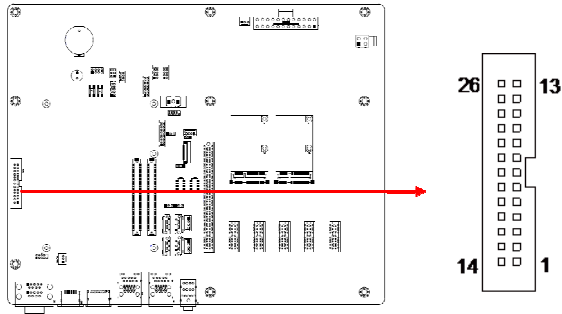

Pin	Signal Name	Pin	Signal Name
1	Line printer strobe	14	AutoFeed
2	PD0, parallel data 0	15	Error
3	PD1, parallel data 1	16	Initialize
4	PD2, parallel data 2	17	Select
5	PD3, parallel data 3	18	Ground
6	PD4, parallel data 4	19	Ground
7	PD5, parallel data 5	20	Ground
8	PD6, parallel data 6	21	Ground
9	PD7, parallel data 7	22	Ground
10	ACK, acknowledge	23	Ground
11	Busy	24	Ground
12	Paper empty	25	Ground
13	Select	26	NC

2.4.6 Digital I/O Connector (J9)

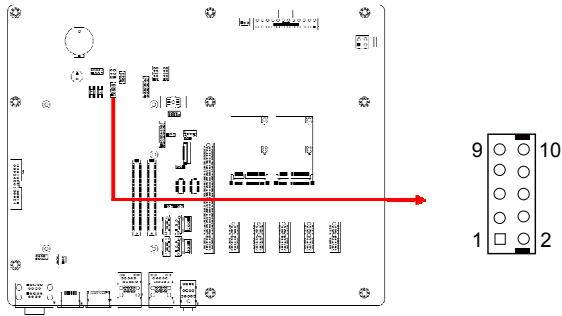

Pin	Signal Name	Pin	Signal Name
1	Gorund	2	VCC
3	OUT3	4	OUT1
5	OUT2	6	OUT0
7	IN3	8	IN1
9	IN2	10	IN0

2.4.7 Panel Inverter Power Connector (J7)

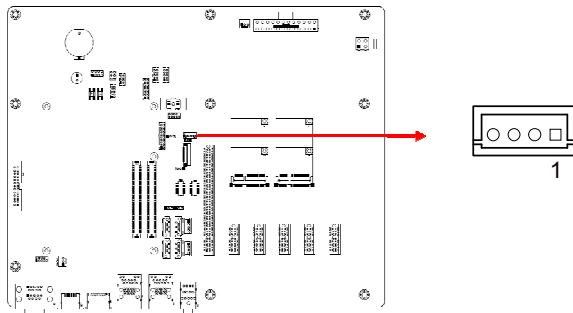

Pin	Signal Name	Pin	Signal Name
1	+12V	3	ADJ
2	Backlight Enable	4	Ground

2.4.8 LVDS Connector (CN11, CN12)

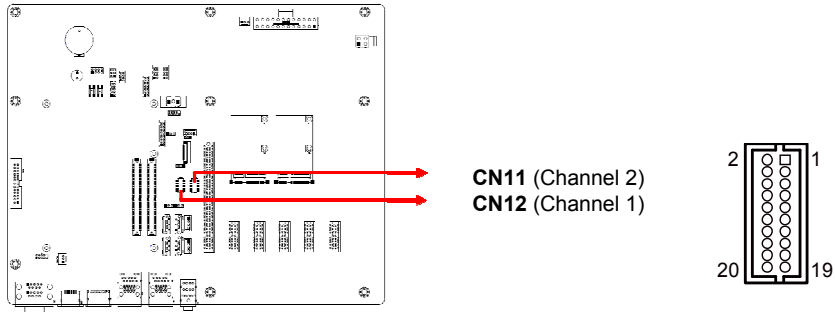

Pin	Signal Name	Pin	Signal Name
1	TX0P	2	TX0N
3	Ground	4	Ground
5	TX1P	6	TX1N
7	Ground	8	Ground
9	TX2P	10	TX2N
11	Ground	12	Ground
13	CLKP	14	CLKN
15	Ground	16	Ground
17	TX3P	18	TX3N
19	Power	20	Power

2.4.9 USB 2.0 Connector (J10)

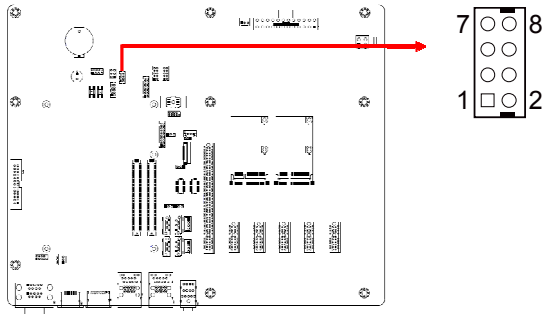

Pin	Signal Name	Pin	Signal Name
1	VCC	2	Ground
3	D0-	4	D1+
5	D0+	6	D1-
7	Ground	8	VCC

2.4.10 COM3 & COM4 RX/TX Port (J11, J12)

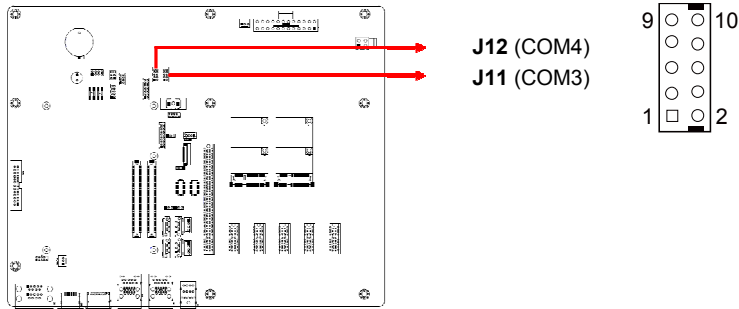

Pin	Signal Name	Pin	Signal Name
1	NC	2	RXD, Receive data
3	TXD, Transmit data	4	NC
5	Ground	6	NC
7	NC	8	NC
9	Ground	10	NC

2.4.11 System Function Connector (J13)

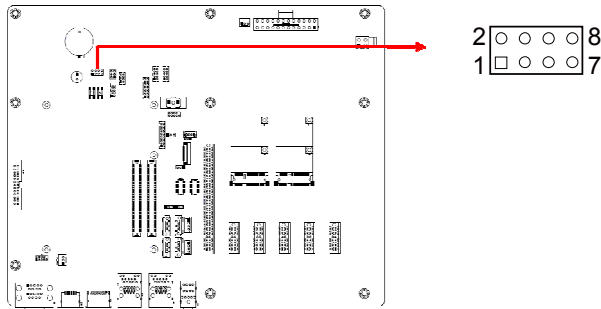

Pin	Signal Name	Pin	Signal Name
1	Power BTN	2	Power BTN
3	HDD LED+	4	HDD LED-
5	Reset BTN	6	Reset BTN
7	Power LED+	8	Power LED-

J13 is utilized for system indicators to provide light indication of the computer activities and switches to change the computer status. It provides interfaces for the following functions.

- ATX Power ON Switch (Pins 1 and 2)**
 The 2 pins make an “ATX Power Supply On/Off Switch” for the system that connects to the power switch on the case. When pressed, the power switch will force the system to power on. When pressed again, it will power off the system.
- Hard Disk Drive LED Connector (Pins 3 and 4)**
 This connector connects to the hard drive activity LED on control panel. This LED will flash when the HDD is being accessed.
- Reset Switch (Pins 5 and 6)**
 The reset switch allows you to reset the system without turning the main power switch off and then on again. Orientation is not required when making a connection to this header.
- Power LED (Pins 7 and 8)**
 This connector connects to the system power LED on control panel. This LED will light when the system turns on.

2.4.12 Fan Power Connector (CPU_FAN1, SYS_FAN1)

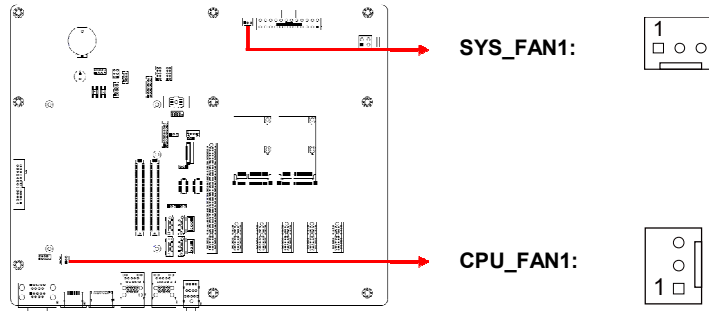

Pin	Assignment	Pin	Assignment
1	Ground	3	NC
2	+12V		

2.4.13 ATX 12V Power Connector (J14)

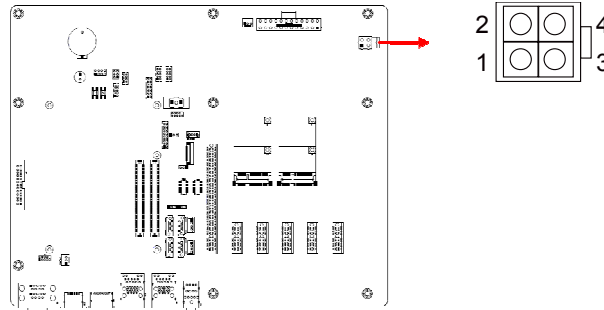

Note: ATX 12V Power Connector (J14) is available for IP418-DC only.

Pin	Signal Name	Pin	Signal Name
1	Ground	2	Ground
3	+12V	4	+12V

2.4.14 ATX Power Connector (J15)

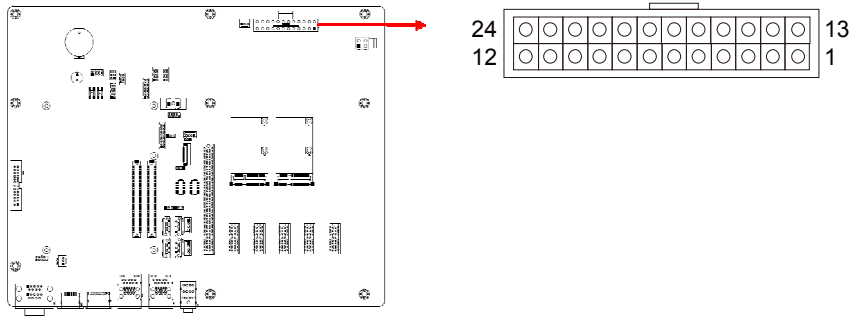

Note: ATX Power Connector (J15) is available for **IP418** only.

Pin	Signal Name	Pin	Signal Name
1	3.3V	13	3.3V
2	3.3V	14	-12V
3	Ground	15	Ground
4	+5V	16	PS-ON
5	Ground	17	Ground
6	+5V	18	Ground
7	Ground	19	Ground
8	Power good	20	-5V
9	5VSB	21	+5V
10	+12V	22	+5V
11	+12V	23	+5V
12	+3.3V	24	Ground

2.4.15 eDP Connector (CN13)

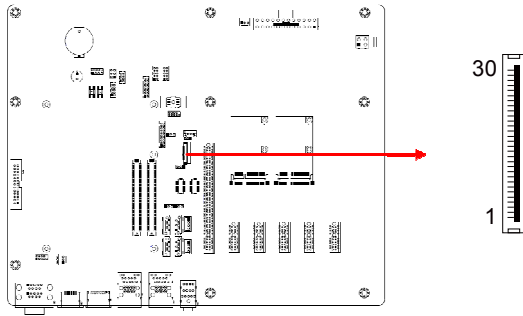

Pin	Signal Name	Pin	Signal Name
1	NC	16	Ground
2	BL_Power	17	NC
3	BL_Power	18	Panel_VDD
4	BL_Power	19	Panel_VDD
5	BL_Power	20	Ground
6	NC	21	AUX_N
7	NC	22	AUX_P
8	Brightness	23	Ground
9	Bklt_en	24	TX0_P
10	Ground	25	TX0_N
11	Ground	26	Ground
12	Ground	27	TX1_P
13	Ground	28	TX1_N
14	HPD	29	Ground
15	Ground	30	NC

Appendix

This section provides the mapping addresses of peripheral devices, the sample code of watchdog timer configuration, and types of on-board connectors.

A. Onboard Connector Types

Function	Connector Name	Onboard Type	Compatible Mating Type for Reference
COM1 & COM2 RS-232 Ports	CN6	Yimtex 40909AANSABR	D-SUB 9P (Female)
SATA Power Connector	J2, J3	JST B4B-XH-A	JST XHP-4
VGA Port	VGA1	HRS DF11-16DP-2DSA	HRS DF11-16DS-2C
DVI-D Port	J6	HRS DF11-20DP-2DSA	HRS DF11-20DS-2C
Parallel Port	LPT1	WIN WIN F-WBOX-26RN	Dupont 26P, pitch 2.54 mm (Female)
Digital I/O Connector	J9	HRS DF11-10DP-2DSA	HRS DF11-10DS-2C
Panel Inverter Power Connector	J7	JST B4B-PH-K-S	JST PHR-4
LVDS Connector	CN11 (Channel 2), CN12 (Channel 1)	HRS DF20F-20DP-1V	HRS DF20A-20DS-1C
USB 2.0 Connector	J10	HRS DF11-8DP-2DSA	HRS DF11-8DS-2C
COM3 & COM4 RX/TX Port	J12 (COM3), J11 (COM4)	HRS DF11-10DP-2DSA	HRS DF11-10DS-2C
System Function Connector	J13	E-call 0126-01-203-080	Dupont 8P, pitch 2.54 mm (Female)
Fan Power Connector	CPU_FAN1, SYS_FAN1	Molex 22-27-2031	HRS DF13-20DS-1.25C
ATX 12V Power Connector ^[1]	J14	HAOGUO ATX4PT-NY46	Molex 39-01-2040
ATX Power Connector	J15	HaoGuo 01-0018-03	Molex 39-01-2240
eDP Connector	CN13	I-PEX 20374-030E-31	I-PEX 20373-R30T-06

[1] ATX 12V Power Connector (J14) is only available for IP418-DC.