

IBR-SMB

Ruggedized Edge Computer with NXP i.MX 8M Plus Lite - ARM Cortex-A53 Quad Processor

User's Manual

Version 1.0
(July 2025)



Copyright

© 2025 IBASE Technology, Inc. All rights reserved.

No part of this publication may be reproduced, copied, stored in a retrieval system, translated into any language or transmitted in any form or by any means, including electronic, mechanical, photocopying, or otherwise, without the prior written consent of IBASE Technology, Inc. (hereinafter referred to as "IBASE").

Disclaimer

IBASE reserves the right to make changes and improvements to the products described in this document without prior notice. Every effort has been made to ensure the information in the document is correct; however, IBASE does not guarantee that this document is error-free. IBASE assumes no liability for incidental or consequential damages resulting from misuse of the product, inability to use the product or information in this document, or infringement of third-party rights arising from its use.

Trademarks

All the trademarks, registrations and brands mentioned herein are used for identification purposes only and may be trademarks and/or registered trademarks of their respective owners.

Compliance

CE

The product described in this manual complies with all applicable European Union (CE) directives if it has a CE marking. For systems to remain CE compliant, only CE-compliant parts may be used. Maintaining CE compliance also requires proper cable and cabling techniques.

FC

This product has been tested and found to comply with the limits for a Class B device, pursuant to Part 15 of the FCC Rules. These limits are designed to provide reasonable protection against harmful interference in a residential installation. This equipment generates, uses and can radiate radio frequency energy and, if not installed and used in accordance with manufacturer's instructions, may cause harmful interference to radio communications.

WEEE



This product must not be disposed of as normal household waste, in accordance with the EU directive for waste electrical and electronic equipment (WEEE - 2012/19/EU). Instead, it should be disposed of by returning it to a municipal recycling collection point. Check local regulations for disposal of electronic products.

Green IBASE



This product complies with RoHS 2 restrictions, which prohibit the use of certain hazardous substances in electrical and electronic equipment. The following substances must not exceed the specified concentrations:

- Hexavalent chromium: 1,000 ppm
- Polybrominated biphenyls (PBBs): 1,000 ppm
- Polybrominated diphenyl ethers (PBDEs): 1,000 ppm
- Cadmium: 100 ppm
- Mercury: 1,000 ppm
- Lead: 1,000 ppm
- Bis(2-ethylhexyl) phthalate (DEHP): 1,000 ppm
- Butyl benzyl phthalate (BBP): 1,000 ppm
- Dibutyl phthalate (DBP): 1,000 ppm
- Diisobutyl phthalate (DIBP): 1,000 ppm

Important Safety Information

Carefully read the following safety information before using this device.

Setting up your system:

- Put the device horizontally on a stable and solid surface.
- Do not use this product near water.
- Do not use this product near any heated source.
- Leave plenty of space around the device and do not block the ventilation openings. Never drop or insert any objects of any kind into the openings.

Care during use:

- Do not place heavy objects on the top of the device.
- Make sure to connect the correct voltage to the device. Failure to supply the correct voltage could damage the unit.
- Do not place or allow objects to rest on the power cord, and do not walk on it.
- Ensure that the total ampere rating of all devices plugged into the extension cord does not exceed the cord's ampere rating.
- Do not spill water or any other liquids on your device.
- Always unplug the device and use only neutral cleaning agents when cleaning.
- Use a computer vacuum cleaner to remove dust and particles from the vents.

Product Disassembly

Do not try to repair, disassemble, or make modifications to the device. Doing so will void the warranty and may result in damage to the product or personal injury.



CAUTION

Replace only with the same or equivalent type recommended by the manufacturer. Dispose of used batteries by observing local regulations.

Warranty Policy

- **IBASE standard products:**

24-month (2-year) warranty from the date of shipment. If the date of shipment cannot be ascertained, the product serial numbers can be used to determine the approximate shipping date.

- **3rd-party parts:**

12-month (1-year) warranty from delivery for 3rd-party parts that are not manufactured by IBASE, such as CPU, CPU cooler, memory, storage devices, power adapter, display panel and touch screen.

- * However, products that fail due to misuse, accident, improper installation or unauthorized repair shall be treated as out of warranty and customers shall be billed for repair and shipping charges.

Technical Support & Services

1. Visit the IBASE website at www.ibase.com.tw to find the latest information about the product.
2. If you encounter any technical problems and require assistance from your distributor or sales representative, please prepare and send the following information:
 - Product model name
 - Product serial number
 - Detailed description of the problem
 - Error messages in text or screenshots if any
 - The arrangement of the peripherals
 - Software used (such as OS and application software)
3. If repair service is required, please apply for an RMA number from the IBASE's website or contact your distributor or sales representative for assistance.

Table of Contents

Chapter 1	General Information.....	1
1.1	Introduction.....	2
1.2	Features	2
1.3	Packing List	2
1.4	Specifications	3
1.5	Product View	4
1.6	Dimensions.....	5
Chapter 2	Hardware Configuration.....	7
2.1	Setting the Jumpers.....	8
2.2	Connector Locations on Motherboard	9
2.3	Connectors Quick Reference	10
2.4.1	HAT-Compatible Connector Pin Assignment (P1).....	11
2.4.2	LVDS Display Connector (P13)	12
2.4.3	LCD Power Select Jumper (P16).....	13
2.4.4	ON/OFF Button (SW1).....	14
Chapter 3	Software Setup.....	15
3.1	Make a Recovery SD Card	16
3.1.1	Preparing the Recovery SD card to Install Linux / Android image into eMMC	16
3.1.2	Upgrade Firmware through the Recovery SD Card	17
Chapter 4	BSP Source Guide	19
4.1	Building BSP Source	20
4.1.1	Preparation	20
4.1.2	Building Release	20
4.1.3	Installing Release to Board	20
Appendix	21
A.	Onboard Connector Types	22

Chapter 1

General Information

The information provided in this chapter includes:

- Features
- Packing List
- Specifications
- Product View
- Dimensions

1.1 Introduction

The IBR-SMB is a rugged edge computer powered by the NXP i.MX8M Plus Lite ARM Cortex-A53 Quad processor, designed for demanding industrial applications. It features 1GB DDR4, 4GB eMMC with an SD expansion slot, and multiple connectivity options including COM, USB, LVDS, and Ethernet. The device is characterized by its ruggedized and fanless design, making it ideal for reliable operation in harsh environments.

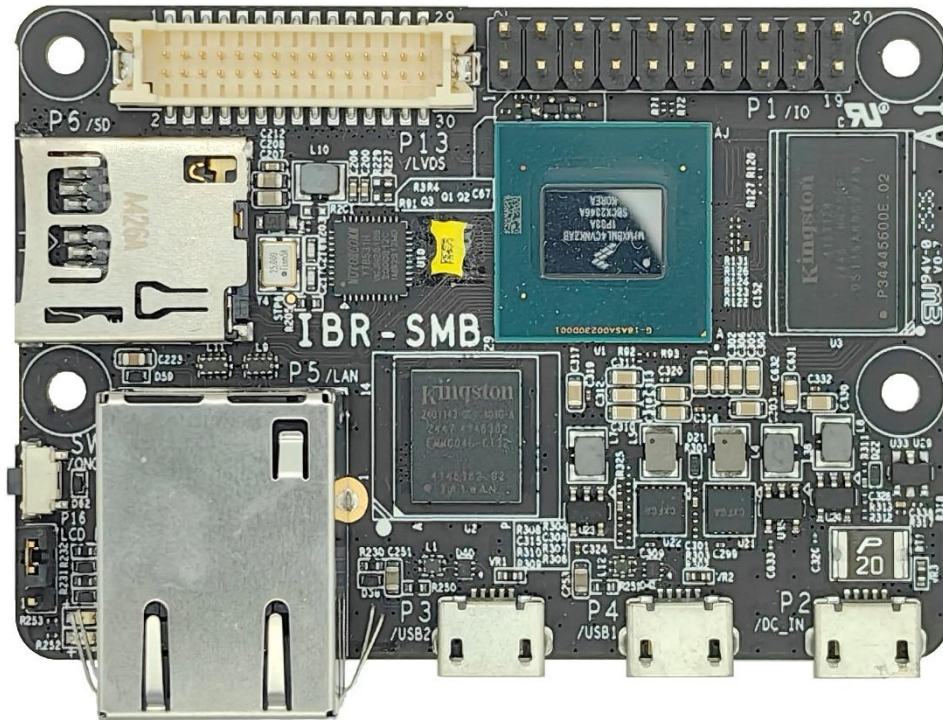

1.2 Features

- NXP Arm Cortex®-A53 Quad Core processor and Arm Cortex® -M7 processor
- 1GB DDR4, 4GB eMMC & SD socket for expansion
- Embedded I/O for LVDS, USB, Ethernet
- Rugged and fanless design

1.3 Packing List

Your product package should include the items listed below.

- IBR-SMB SBC

The user's manual can be downloaded from the IBASE website.

1.4 Specifications

Product Name	IBR-SMB
System	
Operating System	<ul style="list-style-type: none"> • Yocto 3.0 • Other OS (by request)
CPU Type	NXP Cortex®-A53 i.MX8M Plus Lite Quad Core industrial-Grade SoC operating up to 1.6 GHz
MCU Type	Cortex®-M7 CPU operating up to 800 MHz
Memory	1GB DDR4 on board (optional 2GB)
Storage	4GB eMMC on board (up to 256GB)
RTC	IDT 1337AGDVG18
Power Supply	5V DC input through micro USB
Watchdog	256 levels, 0~128 seconds
I/O Ports	
Power	<ul style="list-style-type: none"> • 5V DC input through microUSB
Display	<ul style="list-style-type: none"> • 1 x 8-lane or 2 x 4-lane LVDS 2*15 WTB connector
Display Power Select Jumper	<ul style="list-style-type: none"> • 1 x 3-pin pin header
LAN	<ul style="list-style-type: none"> • 1 x RJ45 GbE LAN
USB	<ul style="list-style-type: none"> • 1 x microUSB2 OTG for 2D Barcode Reader / USB I/F • 1 x microUSB3 OTG for debug or image download For USB WIFI Dongle
HAT- Compatible (20PIN)	2 x 10pin 2.0mm pitch pin header, include: <ul style="list-style-type: none"> • 5V & 3.3V power output support • 7 x GPIO max • 1 x I2C bus • 1 x SPI bus with 1cs • 1 x PWM • 2 x UART
Micro SD	<ul style="list-style-type: none"> • 1x SD socket (UHS-I SDR-104, 104MB/s max)
Button	<ul style="list-style-type: none"> • 1x ON/OFF Button
Dimension	
Dimensions	65mm x 45mm, Top = connector max, Bottom = 2.4mm max
Environment	
Operating Temperature	Design target: Consumer grade: 0~50°C (design target) Future option: Industrial grade: -40°C ~ 80°C (head sink required)
Relative Humidity	0 % to 90 % RH at 60° C (non-condensing)
Shock	Non-Operating: 1G, 15 mins (x-, y-, z-axis)

Vibration	Non-operating: 3 Hz to 500 Hz, 15 mins
RoHS	Yes
Certification	CE, FCC Class B

All specifications are subject to change without prior notice.

1.5 Product View

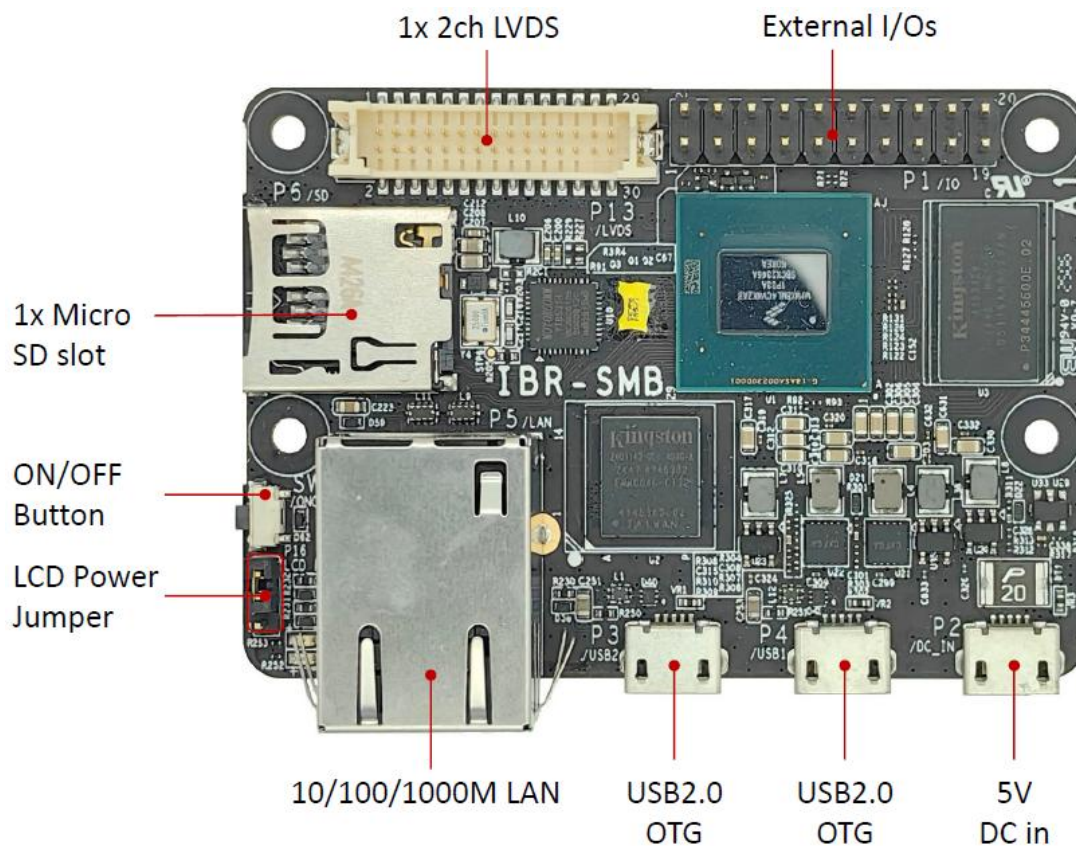

1.6 Dimensions

Unit: mm

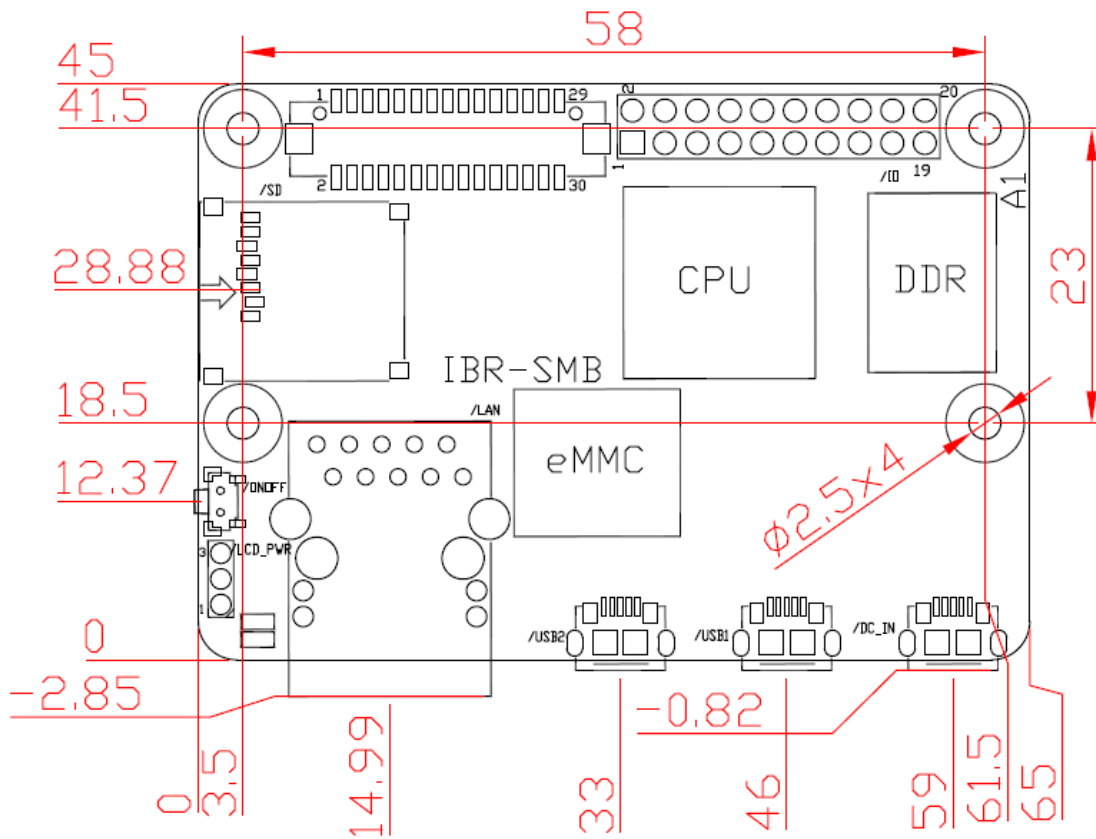

This page is intentionally left blank.

Chapter 2

Hardware Configuration

This section contains general information about:

- Installations
- Connectors

2.1 Setting the Jumpers

Use the jumpers to configure your device for the features required by your application. If you are unsure of the correct settings, please consult your supplier.

2.2.1 How to Set Jumpers

Jumpers are metal pins on the PCB. Jumper caps close the circuit by connecting two pins. 3-pin jumper allows two possible settings: pins 1–2 closed or pins 2–3 close

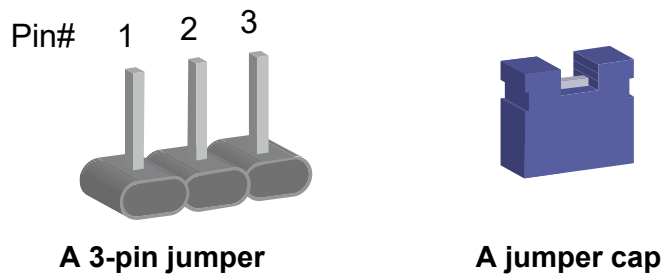

Refer to the illustration below to set jumpers.

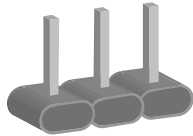
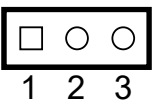
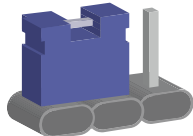
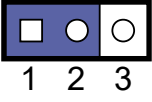
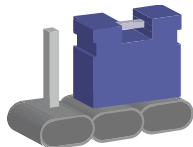
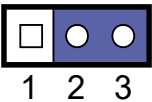
Pin closed	Oblique view	Setting
Open		 1 2 3
1-2		 1 2 3
2-3		 1 2 3

When two pins of a jumper are encased in a jumper cap, this jumper is closed (ON). When the jumper cap is removed, the jumper is open (OFF).

2.2 Connector Locations on Motherboard

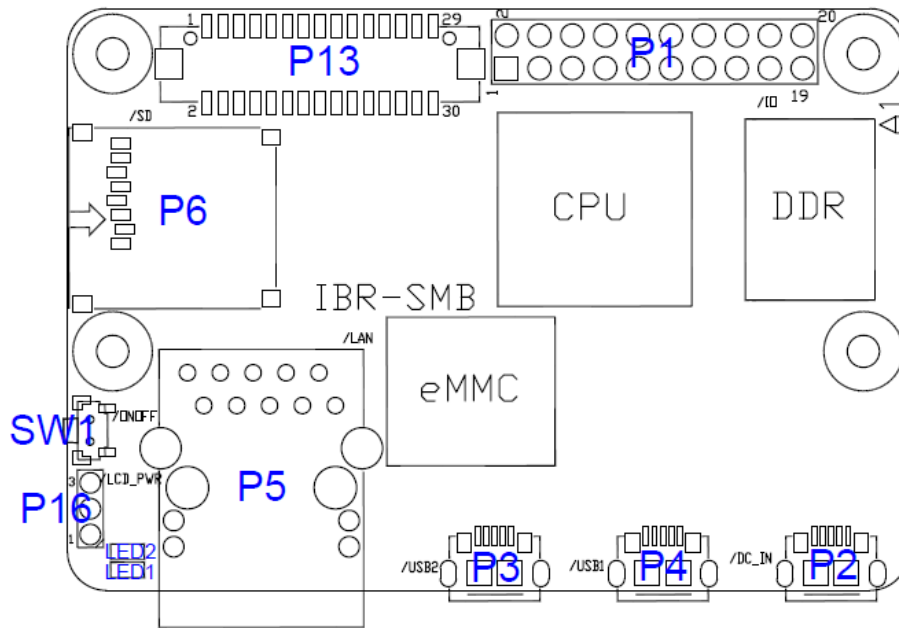

2.3 Connectors Quick Reference

Function	Connector
HAT-Compatible (20PIN)	P1
DC 5V Power Input	P2
MicroUSB2 OTG	P3
MicroUSB1 OTG	P4
10/100/1000M RJ45 LAN	P5
MicroSD Slot	P6
LVDS Display Connector	P13
LCD Power Select Jumper	P16
ON/OFF Button	SW1
System LED	LED1
Power LED	LED2

2.4.1 HAT-Compatible Connector Pin Assignment (P1)

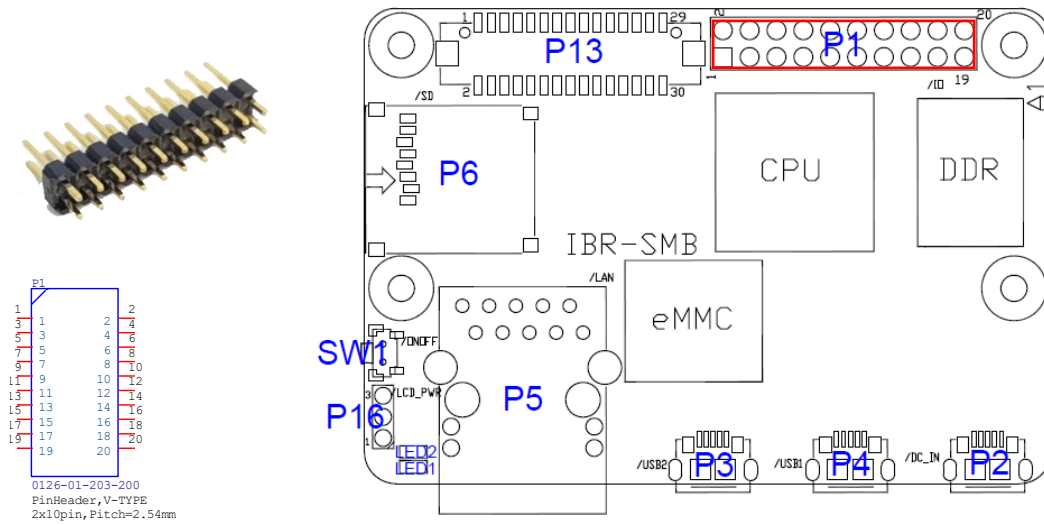

Pin	Signal Name	Pin	Signal Name
1	3.3V	2	5V
3	SDA2	4	5V
5	SCL2	6	Ground
7	GPIO5_03/PWM3_OUT	8	TXD1
9	Ground	10	RXD1
11	GPIO5_07/CSPI1_MOSI	12	GPIO5_09/CSPI1_SS0
13	GPIO5_08/CSPI1_MISO	14	Ground
15	GPIO5_06/CSPI1_SCLK	16	TXD2
17	3.3V	18	RXD2
19	BOOT_MODE0	20	Ground

2.4.2 LVDS Display Connector (P13)

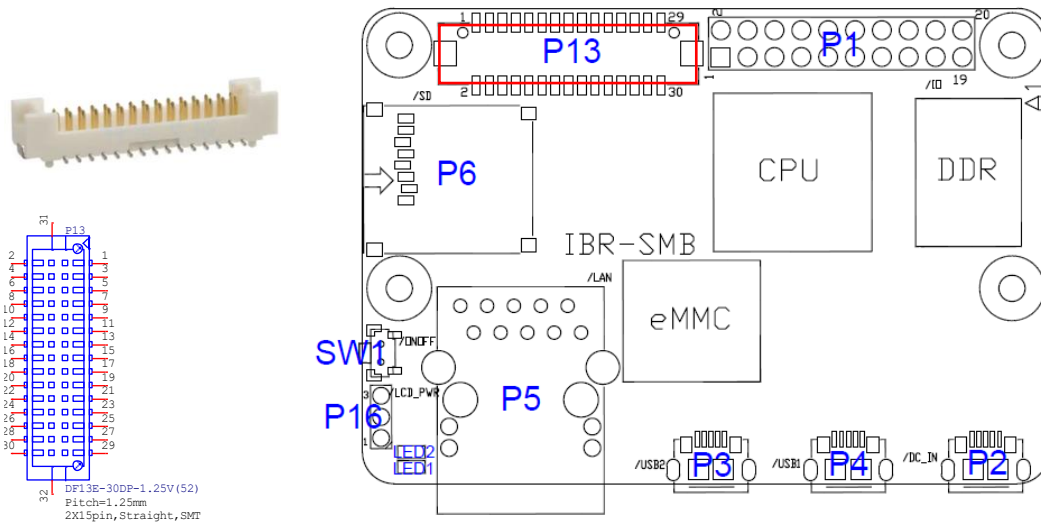

Pin	Signal Name	Pin	Signal Name
2	LCD0_TX0_N	1	LCD0_TX0_P
4	Ground	3	Ground
6	LCD0_TX1_N	5	LCD0_TX1_P
8	3.3V/5V	7	Ground
10	LCD0_TX3_N	9	LCD0_TX3_P
12	LCD0_TX2_N	11	LCD0_TX2_P
14	Ground	13	Ground
16	LCD0_CLK_N	15	LCD0_CLK_P
18	3.3V/5V	17	BKLT_PWM
20	3.3V/5V	19	BKLT_EN
22	LCD1_TX0_N	21	LCD1_TX0_P
24	LCD1_TX1_N	23	LCD1_TX1_P
26	LCD1_TX3_N	25	LCD1_TX3_P
28	LCD1_TX2_N	27	LCD1_TX2_P
30	LCD1_CLK_N	29	LCD1_CLK_P

2.4.3 LCD Power Select Jumper (P16)

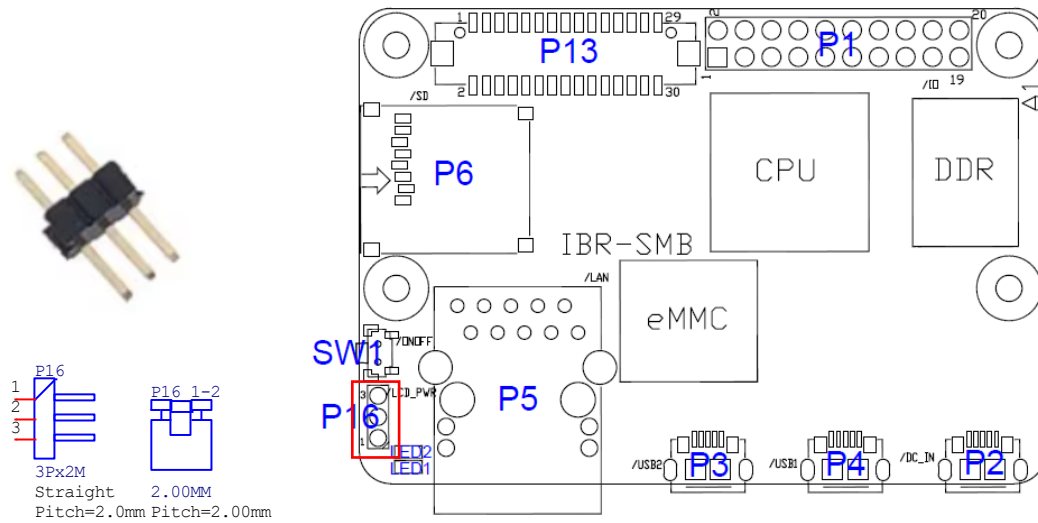

Function	Pin closed
3V3	1-2
5V	2-3

2.4.4 ON/OFF Button (SW1)

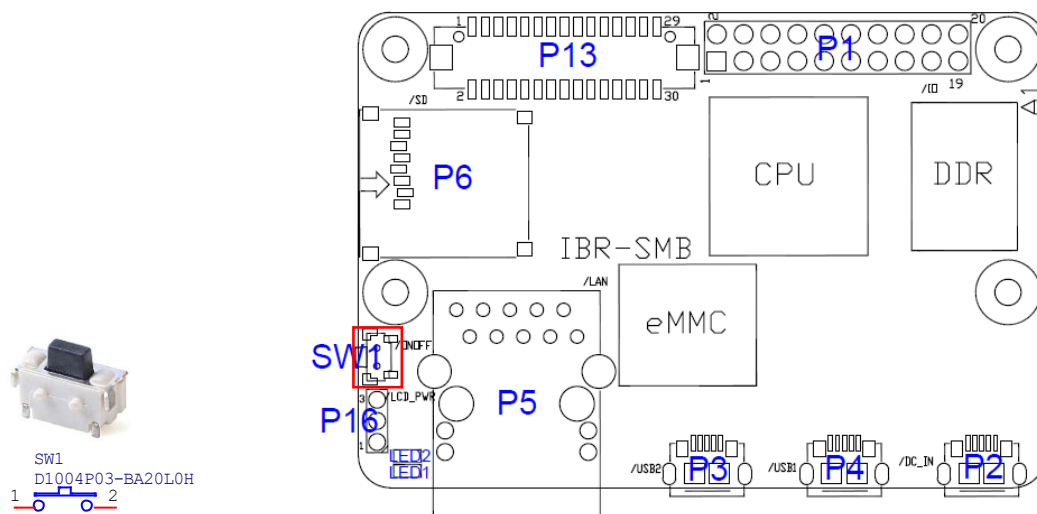

SW1: On/Off Button

Pin	Signal Name	Pin	Signal Name
1	ONOFF_B	2	Ground

Chapter 3

Software Setup

This chapter introduces the following setup on the device:

(For advanced users only)

- Make a recovery SD card
- Upgrade firmware through the recovery SD card

3.1 Make a Recovery SD Card

Note: This is for advanced users who have the IBASE standard image file only.

Basically, IBR-SMB is preloaded with O.S (Android or Yocto) into eMMC by default.

This chapter guides you to make a recovery boot-up microSD card.

3.1.1 Preparing the Recovery SD card to Install Linux / Android image into eMMC

Note: All data in the eMMC will be erased.

- 1) System requirements:
 Operating System: Windows 7 or later
 Tool: uuu
 SD card size: 4GB or greater in size
- 2) Insert Micro SD card to P6, connect the board to PC through the Micro-USB port P4, and short P1 pin 17&19 set the boot mode to download mode.

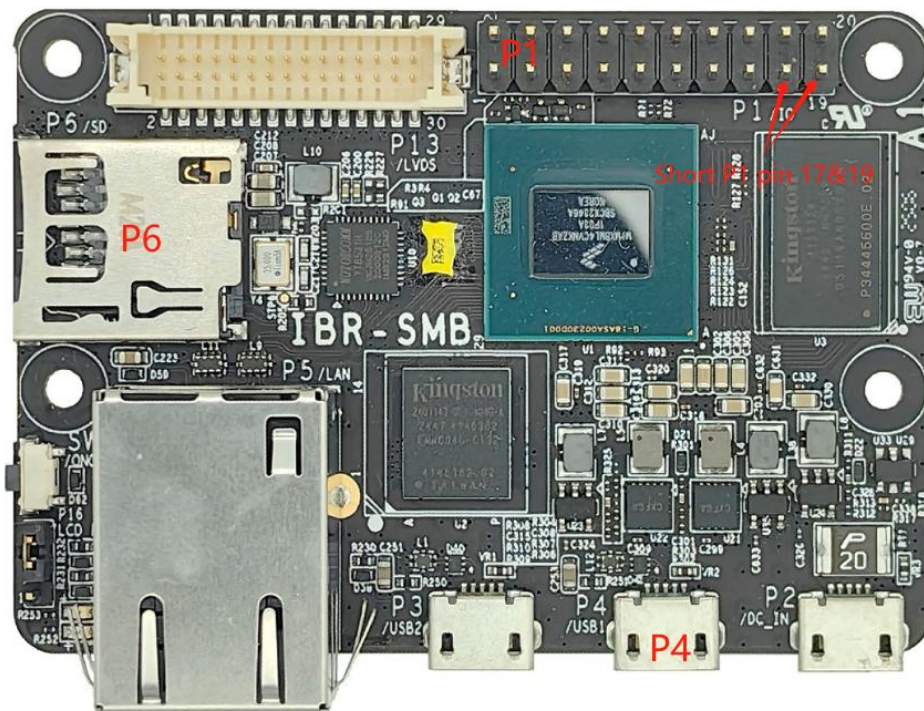

- 3) Push DC 5V power into P2 with a microUSB cable.

Boot IBR-SMB and flash SD via CMD command “uuu.exe uuu-sdcard.auto” or double click “FW_down-sdcard.bat”.

changelog.txt	2025/4/8 18:05	Text Document	2 KB
FW_down-emmc.bat	2025/3/10 17:22	Windows 批处理文件	1 KB
FW_down-sdcard.bat	2025/3/10 17:22	Windows 批处理文件	1 KB
FW_down-uboot.bat	2025/3/10 17:22	Windows 批处理文件	1 KB
Image	2025/4/8 17:53	文件	31,367 KB
imx8mp-ddr4-evk.dtb	2025/4/8 17:53	DTB 文件	54 KB
imx8mp-ddr4-evk-lm215wf3-lvds-panel.dtb	2025/4/8 17:53	DTB 文件	54 KB
imx8mp-ddr4-evk-lq150x1lx95-lvds-panel...	2025/4/8 17:53	DTB 文件	54 KB
imx8mp-ddr4-evk-ptjmtlcd050001-lvds-p...	2025/4/8 17:53	DTB 文件	54 KB
imx-boot-ddr4-imx8mpevk-sd.bin-flash_evk	2025/4/8 17:53	BIN-FLASH_EVK 文件	1,234 KB
imx-image-multimedia-imx8mpevk.sdcard	2025/4/8 18:01	SDCARD 文件	2,985,840 KB
recovery.tar.bz2	2025/4/8 17:59	压缩存档文件夹	124,367 KB
rootfs.tar.bz2	2025/4/8 17:58	压缩存档文件夹	584,191 KB
uuu.auto	2025/3/10 17:22	AUTO 文件	2 KB
uuu_1.4.95.exe	2025/3/10 17:22	应用程序	1,273 KB
uuu-sdcard.auto	2025/3/10 17:22	AUTO 文件	1 KB
uuu-uboot.auto	2025/3/10 17:22	AUTO 文件	1 KB

3.1.2 Upgrade Firmware through the Recovery SD Card

1) Put recovery files into U disk (FAT32)

A> Yocto/Ubuntu: Copy all recovery files into PATH: `/hmsupdate/yocto/`

名称	修改日期
rootfs.tar.bz2	2022/10/24 10:22
Image	2022/10/24 10:14
imx8mp-ddr4-evk.dtb	2022/10/24 10:14
imx-boot-ddr4-imx8mpevk-sd.bin-flash_evk	2025/4/14 11:01
imx-image-multimedia-imx8mpevk.sdcard	2022/10/24 11:20
recovery.tar.bz2	2022/10/24 10:23

B> Android: Copy all recovery files into PATH: `/hmsupdate/android/`

- 2) Plug microSD (Section 3.3.1) and U disk into IBR-SMB with a USBOTG cable.
- 3) Change IBR-SMB back to Normal boot mode (opened P1 pin 17&19).
- 4) Power on and the system will recovery eMMC automatically.
- 5) When the upgrade finished, LED1 will flash every 2 seconds, then power off and remove the microSD card and U disk

Note: LED1 status description: (Linux OS only)

- Upgrading: Always ON, then OFF a short time per 2s;
- Upgrade Completed: Always OFF, then ON a short time per 2s;
- Upgrade error: Flashing per 0.1s;

This page is intentionally left blank.

Chapter 4

BSP Source Guide

This chapter is dedicated to advanced software engineers building the BSP source. The topics covered in this chapter are as follows:

- Preparation
- Building Release
- Installing Release to Board

4.1 Building BSP Source

4.1.1 Preparation

The recommended minimum Ubuntu version is 18.04 or later.

1) Install necessary packages before building:

```
sudo apt-get install gawk wget git-core diffstat unzip texinfo gcc-multilib \
build-essential chrpath socat cpio python python3 python3-pip python3-pexpect \
xz-utils debianutils iputils-ping python3-git python3-jinja2 libegl1-mesa libsdl1.2-dev \
pylint3 xterm
```

2) Decompress the IBR-SMB source file (example tvmb_bsp_source_20231107-1538.tar.bz2) into "/home/" folder.

4.1.2 Building Release

For Yocto/Ubuntu/Debian

```
cd /home/bsp-folder
./build-bsp-5.4.sh
```

4.1.3 Installing Release to Board

```
cd /home/bsp-folder
for yocto/Ubuntu/debian

1. cp file in release/ to windows
2. set board to download mode, and connect otg to usb

Run Fw_download-emmc.bat
```

Appendix

This chapter contains the following information:

Onboard Connector Types

A. Onboard Connector Types

Function	Connector	Onboard Type	Compatible Mating Type for Reference
HAT-Compatible (20-pin)	P1	E-Call 0126-01-203-200	-
LVDS Display Connector	P13	Hirose DF13E-30DP- 1.25V	Hirose DF13-30DS-1.25C

Connector types may be subject to change without prior notice.