

# **IB995**

**Intel® 8th or 9th Gen. Xeon. Core™ i7/i5/i3  
Full-Size CPU Card**

## **User's Manual**

Version 1.1b  
(July 2022)

**Copyright**

© 2021 IBASE Technology, Inc. All rights reserved.

No part of this publication may be reproduced, copied, stored in a retrieval system, translated into any language or transmitted in any form or by any means, electronic, mechanical, photocopying, or otherwise, without the prior written consent of IBASE Technology, Inc. (hereinafter referred to as “IBASE”).

**Disclaimer**

IBASE reserves the right to make changes and improvements to the products described in this document without prior notice. Every effort has been made to ensure the information in the document is correct; however, IBASE does not guarantee this document is error-free.

IBASE assumes no liability for incidental or consequential damages arising from misapplication or inability to use the product or the information contained herein, nor for any infringements of rights of third parties, which may result from its use.

**Trademarks**

All the trademarks, registrations and brands mentioned herein are used for identification purposes only and may be trademarks and/or registered trademarks of their respective owners.

## Compliance



In a domestic environment, this product may cause radio interference in which case users may be required to take adequate measures.



This product has been tested and found to comply with the limits for a Class A device, pursuant to Part 15 of the FCC Rules. These limits are designed to provide reasonable protection against harmful interference in a residential installation. This equipment generates, uses and can radiate radio frequency energy and, if not installed and used in accordance with manufacturer's instructions, may cause harmful interference to radio communications.

## WEEE



This product must not be disposed of as normal household waste, in accordance with the EU directive of for waste electrical and electronic equipment (WEEE - 2012/19/EU). Instead, it should be disposed of by returning it to a municipal recycling collection point. Check local regulations for disposal of electronic products.

## Green IBASE



This product is compliant with the current RoHS restrictions and prohibits use of the following substances in concentrations exceeding 0.1% by weight (1000 ppm) except for cadmium, limited to 0.01% by weight (100 ppm).

- Lead (Pb)
- Mercury (Hg)
- Cadmium (Cd)
- Hexavalent chromium (Cr6+)
- Polybrominated biphenyls (PBB)
- Polybrominated diphenyl ether (PBDE)

## Important Safety Information

Carefully read the precautions before using the board.

### Environmental conditions:

- Use this product in environments with ambient temperatures between 0°C and 60°C.
- Do not leave this product in an environment where the storage temperature may be below -20° C (-4° F) or above 80° C (176° F). To prevent from damages, the product must be used in a controlled environment.



### WARNING

### Attention during use:

- Do not use this product near water.
- Do not spill water or any other liquids on this product.
- Do not place heavy objects on the top of this product.

### Anti-static precautions

- Wear an anti-static wrist strap to avoid electrostatic discharge.
- Place the PCB on an anti-static kit or mat.
- Hold the edges of PCB when handling.
- Touch the edges of non-metallic components of the product instead of the surface of the PCB.
- Ground yourself by touching a grounded conductor or a grounded bit of metal frequently to discharge any static.



### CAUTION

Danger of explosion if the internal lithium-ion battery is replaced by an incorrect type. Replace only with the same or equivalent type recommended by the manufacturer. Dispose of used batteries according to the manufacturer's instructions or recycle them at a local recycling facility or battery collection point.

## Warranty Policy

- **IBASE standard products:**

24-month (2-year) warranty from the date of shipment. If the date of shipment cannot be ascertained, the product serial numbers can be used to determine the approximate shipping date.

- **3<sup>rd</sup>-party parts:**

12-month (1-year) warranty from delivery for the 3<sup>rd</sup>-party parts that are not manufactured by IBASE, such as CPU, CPU cooler, memory, storage devices, power adapter, panel and touchscreen.

- \* PRODUCTS, HOWEVER, THAT FAIL DUE TO MISUSE, ACCIDENT, IMPROPER INSTALLATION OR UNAUTHORIZED REPAIR SHALL BE TREATED AS OUT OF WARRANTY AND CUSTOMERS SHALL BE BILLED FOR REPAIR AND SHIPPING CHARGES.

## Technical Support & Services

1. Visit the IBASE website at [www.ibase.com.tw](http://www.ibase.com.tw) to find the latest information about the product.
2. If you need any further assistance from your distributor or sales representative, prepare the following information of your product and elaborate upon the problem.
  - Product model name
  - Product serial number
  - Detailed description of the problem
  - The error messages in text or in screenshots if there is any
  - The arrangement of the peripherals
  - Software in use (such as OS and application software, including the version numbers)
3. If repair service is required, please log in to the RMA system of the website or and contact your distributor or sales representative for assistance.

# Table of Contents

---

<b>Chapter 1</b>	<b>General Information .....</b>	<b>1</b>
1.1	Introduction .....	2
1.2	Features .....	2
1.3	Packing List .....	3
1.4	Optional Accessories .....	3
1.5	Specifications .....	4
1.6	Block Diagram.....	6
1.7	Board Pictures .....	7
1.8	Dimensions .....	8
<b>Chapter 2</b>	<b>Hardware Configuration.....</b>	<b>9</b>
2.1	Essential Installations Before You Begin .....	10
2.2	Setting the Jumpers .....	12
2.3	Jumper & Connector Locations on IB995 .....	13
2.4	Jumpers Quick Reference.....	14
2.4.1	ATX / AT Power Mode Selection (JP1).....	14
2.4.2	PCIe (x16) Bifurcation Selection (JP2 & JP3).....	15
2.4.3	LVDS Power Brightness Selection (JP4).....	16
2.4.4	LVDS Panel Power Selection (JP6) .....	16
2.4.5	Clear ME Register (JP8) .....	17
2.4.6	Clear CMOS Data (JP9).....	17
2.5	Connectors Quick Reference .....	18
2.5.1	COM1 RS-232/422/485 & COM2 RS-232 Serial Port (J25) .	19
2.5.2	COM2-COM4 RS-232 Ports (J26, J5, J6).....	20
2.5.3	Digital I/O Connector (J2).....	21
2.5.4	LCD Backlight Connector (J10).....	21
2.5.5	ATX Power Connector (J7) .....	22
2.5.6	USB3.0/2.0 Connector (J8, J9) .....	23
2.5.7	Dual USB 2.0 Connector (J16).....	24
2.5.8	Front Panel Audio Connector (J18).....	24
2.5.9	Front Panel Settings Connector (J3) .....	25
2.5.10	LVDS Connector (J11, J12) .....	26
2.5.11	Fan Power Connector (CPU_FAN1) .....	27
2.5.12	DVI-D Connector (J20) .....	28
2.5.13	Parallel Port (J24) .....	29

<b>Chapter 3</b>	<b>Drivers Installation .....</b>	<b>31</b>
3.1	Introduction .....	32
3.2	Intel® Chipset Software Installation Utility .....	33
3.3	VGA Driver Installation .....	35
3.4	HD Audio Driver Installation .....	38
3.5	LAN Driver Installation .....	39
3.6	Intel® Management Engine Interface .....	42
<b>Chapter 4</b>	<b>BIOS Setup .....</b>	<b>45</b>
4.1	Introduction .....	46
4.2	BIOS Setup .....	46
4.3	Main Settings .....	48
4.4	Advanced Settings .....	49
4.5	Chipset Settings .....	62
4.6	Security Settings .....	65
4.7	Boot Settings .....	69
4.8	Save & Exit Settings .....	70
<b>Appendix</b>	<b>.....</b>	<b>71</b>
A.	I/O Port Address Map .....	72
B.	Interrupt Request Lines (IRQ) .....	73
C.	Watchdog Timer Configuration .....	74



# Chapter 1

## General Information

The information provided in this chapter includes:

- Features
- Packing List
- Optional Accessories
- Block Diagram
- Specifications
- Board View
- Board Dimensions

## 1.1 Introduction

The IB995AF PICMG1.3 SHB Express CPU Card is based on the latest 8th or 9th Gen. Intel® Xeon® E / Core™ / Pentium® / Celeron® processor with speeds of up to 4.7GHz and features an integrated graphics core that work with LVDS, DVI-I and DVI-D display outputs.

IB995 utilizes the dramatic increase in performance provided by Intel's latest cutting-edge technology. Measuring 338mm x122mm, IB995 offers fast 6Gbps SATA support (up to 8 ports), USB3.1 (5 ports) and interfaces for two Gigabit LAN.

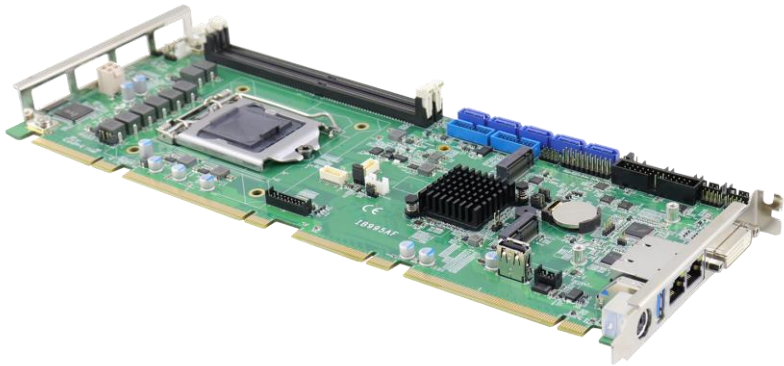

Photo of IB995

## 1.2 Features

- 2 x DDR4-2400/2666 UDIMM, expandable up to 32GB, ECC supported per CPU SKUS.
- Dual Gigabit LAN
- 1 x DVI-I , 1 x DVI-D, 1 x 24-bit dual channel LVDS
- 5 x USB 3.1, 8 x SATA III, 4 x serial ports
- PCIe (x16), M.2 M2280 (for IB995AF series only) and M.2 E2230 expansion slots
- Configurable watchdog timer, digital I/O, TPM

### **1.3 Packing List**

Your IB995 package should include the items listed below. If any of the items is missing, please contact the distributor or dealer from whom you have purchased the product.

- IB995AF PICMG1.3 SHB x 1
- I/O shield
- SATA cable (SATA-5)
- COM port cable (PK1-150)

### **1.4 Optional Accessories**

- Audio cable (Audio-18)
- DVI-D cable (DVIK-3)
- USB cable (USB-29)
- USB3.0 cable (USB-3K)
- Printer port cable (PK3K)

## 1.5 Specifications

<b>Product Name</b>	<b>IB995AF Series</b>	<b>IB995EF</b>
<b>Form Factor</b>	PICMG 1.3 SHB Express full size CPU card	
<b>System</b>		
<b>Operating System</b>	<ul style="list-style-type: none"> <li>• Microsoft Windows 10 (64-bit)</li> <li>• Linux Ubuntu (64-bit)</li> </ul>	
<b>CPU &amp; Chipset</b>	9 <sup>th</sup> / 8 <sup>th</sup> Gen. Intel® Xeon® E / Core™ / Pentium® / Celeron®, up to 4.7 GHz	
<b>Memory</b>	2 x DDR4 UDIMM 2666 / 2400 MHz, up to 32 GB * ECC will be supported by identified CPU SKUs.	
<b>Storage</b>	M.2 M2280 slot (NVMe supported)	N/A
<b>Graphics</b>	Intel® UHD Graphics P630	
<b>LAN</b>	1 <sup>st</sup> LAN: Intel® I219LM GbE 2 <sup>nd</sup> LAN: Intel® I210AT / I211AT GbE	1 <sup>st</sup> LAN: Intel® I219V GbE 2 <sup>nd</sup> LAN: Intel® I211AT GbE
<b>Security</b>	TPM 2.0	
<b>Super I/O</b>	Fintek F81964D-I	
<b>Digital I/O</b>	4-In / 4-Out	
<b>Audio Codec</b>	Built HD audio with Realtek ALC662	
<b>Watchdog Timer</b>	Yes (256 segments, 0, 1, 2...255 sec / min)	
<b>BIOS</b>	AMI BIOS	
<b>iSmart</b>	N/A	
<b>RAID</b>	RAID 0/1/5	N/A
<b>iAMT</b>	11.6 (with E-Xeon® / Core i7/ i5 DT CPU SKUs)	N/A
<b>TPM</b>	2.0	
<b>Dimensions</b>	338mm x 126mm	
<b>RoHS</b>	Yes	
<b>Certification</b>	CE, FCC	

Model	IB995AF Series	IB995EF
<b>I/O Ports</b>		
<b>Display</b>	<ul style="list-style-type: none"> <li>• 1 x DVI-D (1920 x 1080 at 60 Hz)</li> <li>• 1 x DVI-I (1920 x 1080 at 60 Hz)</li> <li>• 1 x 24-bit dual channel LVDS (1920 x 1080 at 60 Hz)</li> </ul>	
<b>LAN</b>	<ul style="list-style-type: none"> <li>• 2 x RJ45 GbE LAN</li> <li>• 1 x M.2 (E-key@2230), Support CNVi</li> </ul>	
<b>USB</b>	<ul style="list-style-type: none"> <li>• 1 x USB 3.1 (I/O coastline connectors)</li> <li>• 4 x USB 3.1 (via two onboard pin-header)</li> <li>• 1 x USB 2.0 ports (via M.2 E2230)</li> <li>• 1 x USB 2.0 (Vertical type A)</li> <li>• 2 x USB 2.0 (via an onboard pin-header)</li> <li>• 4 x USB 2.0 to Backplane</li> </ul>	<ul style="list-style-type: none"> <li>• 1 x USB 3.1 (I/O coastline connectors)</li> <li>• 1 x USB 2.0 (Vertical type A)</li> <li>• 4 x USB 2.0 to Backplane</li> </ul>
<b>Serial</b>	<p><b>4 x COM ports:</b></p> <ul style="list-style-type: none"> <li>• COM1: RS-232/422/485 (Support Ring-in with power at 500mA, selectable for 5V or 12V)</li> <li>• COM2 ~ COM4: RS-232 only (via onboard box-headers)</li> </ul>	<p><b>4 x COM ports:</b></p> <ul style="list-style-type: none"> <li>• COM1: RS-232/422/485 (Support Ring-in with power at 500mA, selectable for 5V or 12V)</li> <li>• COM2 ~ COM4: RS-232 only (via onboard box-headers)</li> </ul>
<b>SATA</b>	<ul style="list-style-type: none"> <li>• IB995AF-C246 support 8 ports, 5 x SATAIII (3.0) 6Gbps</li> <li>• IB995AF(Q370) support 6 ports, 3 x SATAIII (3.0) 6Gbps</li> <li>• IB995EF(H310); support 4 ports, 2 x SATAIII (3.0) 6Gbps</li> </ul>	
<b>Digital IO</b>	4-In & 4-Out	
<b>Expansion Slots</b>	<ul style="list-style-type: none"> <li>• 1 x PCIe (x16)</li> <li>• 1 x M.2 M2280</li> <li>• 1 x M.2 E2230</li> </ul>	<ul style="list-style-type: none"> <li>• 1 x PCIe (x16)</li> <li>• 1 x M.2 E2230</li> </ul>
<b>Environment</b>		
<b>Temperature</b>	<ul style="list-style-type: none"> <li>• <b>Operating:</b> 0 ~ 60 °C (32 ~ 140 °F)</li> <li>• <b>Storage:</b> -20 ~ 80 °C (-4 ~ 176 °F)</li> </ul>	
<b>Relative Humidity</b>	0 ~ 90 %, non-condensing at 60 °C	

All specifications are subject to change without prior notice.

## 1.6 Block Diagram

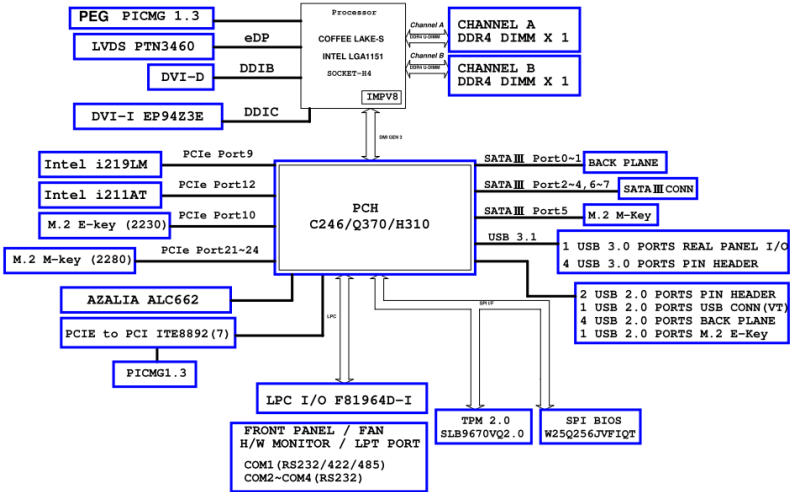

## 1.7 Board Pictures

### Top View

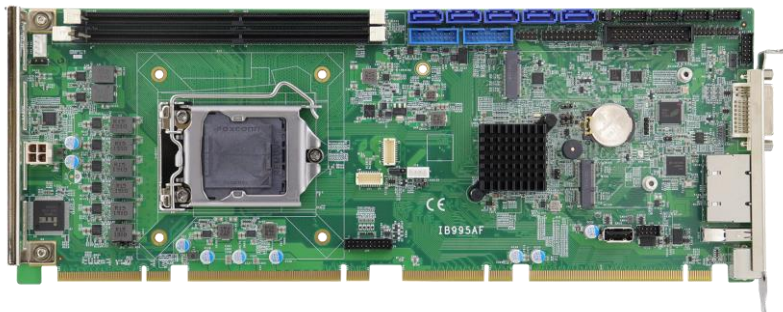

### Bottom View

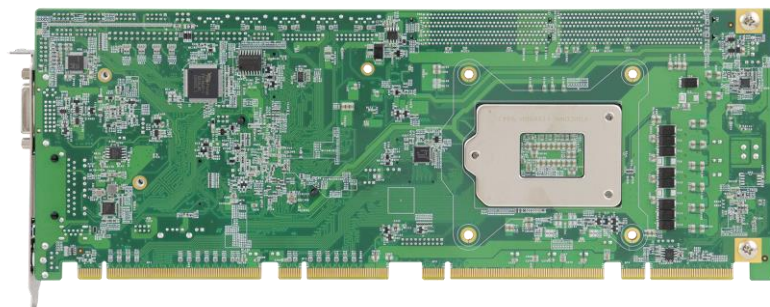

### I/O View



\* The photos above are for reference only.

## 1.8 Dimensions

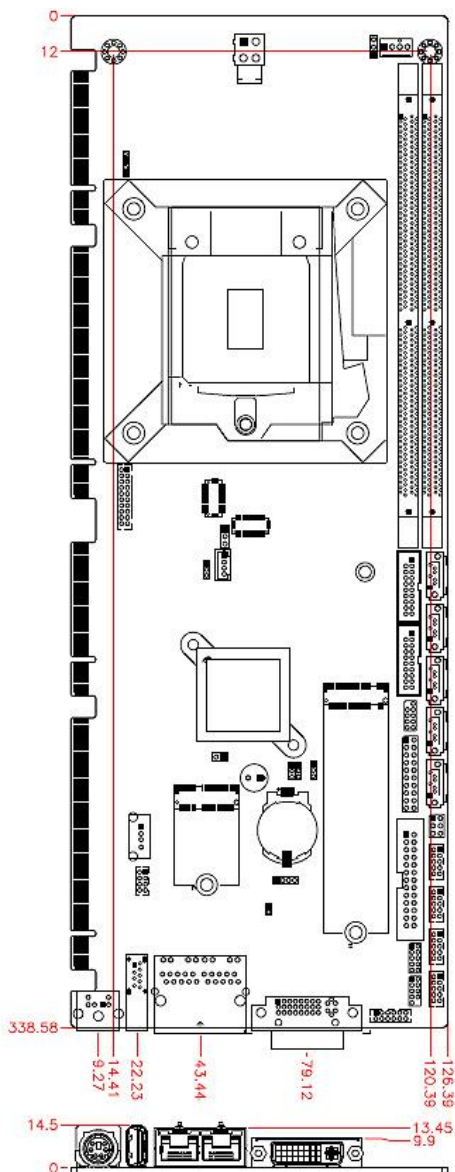

# Chapter 2

## Hardware Configuration

This section provides information on jumper settings and connectors on the IB995 in order to set up a workable system. On top of that, you will also need to install crucial pieces such as the CPU and the memory before using the product. The topics covered are:

- Essential installations
- Jumper and connector locations
- Jumper settings and information of connectors

## 2.1 Essential Installations Before You Begin

Follow the instructions below to install the CPU and the memory.

### 2.1.1 Installing the CPU

The IB995 board supports an LGA1151 Socket (shown below) for Intel® Xeon® E3 v5 family or Intel® 6<sup>th</sup> Gen. Core™ i7 / i5 / i3 DT processor processors. Follow the instructions below to install the CPU.

1. Unlock the socket by pressing the lever sideways, then lift up the lever and the metal lid.
2. Position the CPU above the socket such that the CPU corner aligns with the gold triangle matching the socket corner with a small triangle.
3. Carefully insert the CPU into the socket and push down the lever to secure the CPU.

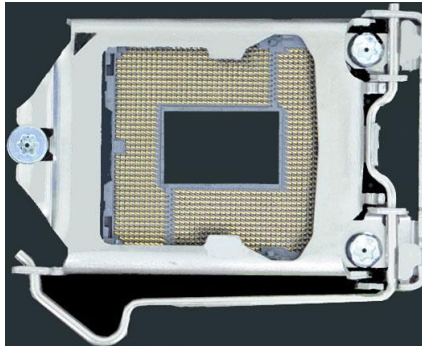

Then you can install the CPU cooler and fan.

---

**Note:** Ensure that the CPU cooler and the CPU top surface are in total contact to avoid CPU overheating problem that would cause your system to hang or be unstable.

---

### 2.1.2 Installing the Memory

The IB995 board supports two DDR4 memory socket for a maximum total memory of 32GB in DDR4 UDIMM memory type. To install the modules, locate the memory slot on the board and perform the following steps:

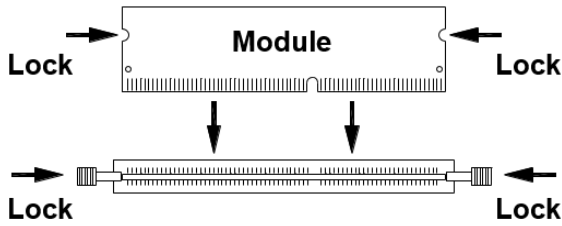

1. Hold the module so that the key of the module aligned with that on the memory slot.
2. Gently push the module in an upright position until the clips of the slot close to hold the module in place when the module touches the bottom of the slot.

To remove the module, press the clips outwards with both hands

## 2.2 Setting the Jumpers

Set up and configure your IB995 by using jumpers for various settings and features according to your needs and applications. Contact your supplier if you have doubts about the best configuration for your use.

### 2.2.1 How to Set Jumpers

Jumpers are short-length conductors consisting of several metal pins with a non-conductive base mounted on the circuit board. Jumper caps are used to have the functions and features enabled or disabled. If a jumper has 3 pins, you can connect either PIN1 to PIN2 or PIN2 to PIN3 by shorting.

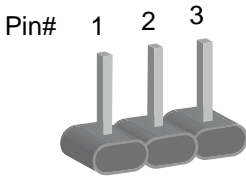



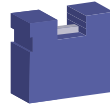



A 3-pin jumper

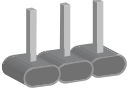

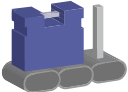
A jumper cap

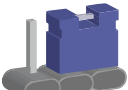
Refer to the illustration below to set jumpers.

Pin closed	Oblique view	Illustration
Open		 1 2 3
1-2		 1 2 3
2-3		 1 2 3

When two pins of a jumper are encased in a jumper cap, this jumper is **closed**, i.e. turned **On**.

When a jumper cap is removed from two jumper pins, this jumper is **open**, i.e. turned **Off**.



## 2.4 Jumpers Quick Reference

Function	Jumper	Page
ATX/AT Power Mode Selection	JP1	14
PCIe Bifurcation Selection	JP2, JP3	15
LVDS Panel Brightness Selection	JP4	16
LVDS Panel Power Selection	JP6	16
Clear ME Register	JP8	17
Clear CMOS Data	JP9	17



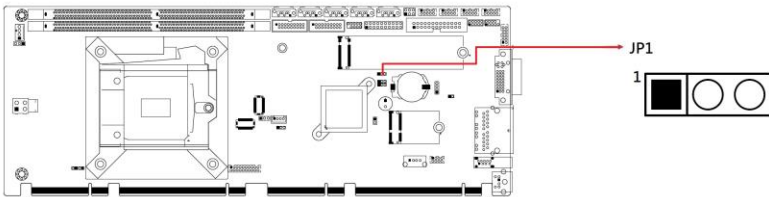



### 2.4.1 ATX / AT Power Mode Selection (JP1)

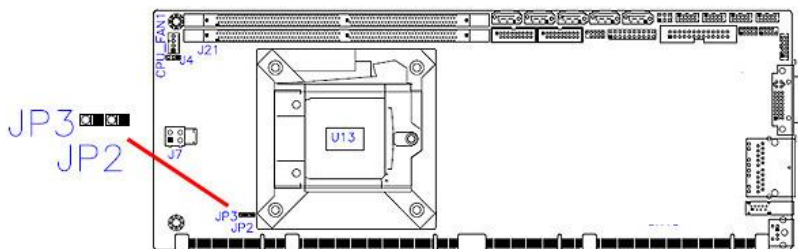

Function	Pin closed	Illustration
ATX Mode (default)	1-2	
AT Mode	2-3	



### 2.4.2 PCIe (x16) Bifurcation Selection (JP2 & JP3)



Function	Pin closed	Illustration
1 x PCIe (x16) (default)	JP3: Open	 1
	JP2: Open	 1
2 x PCIe (x8)	JP3: Open	 1
	JP2: Close	 1
1 x PCIe (x8) 2 x PCIe (x4)	JP3: Close	 1
	JP2: Close	 1

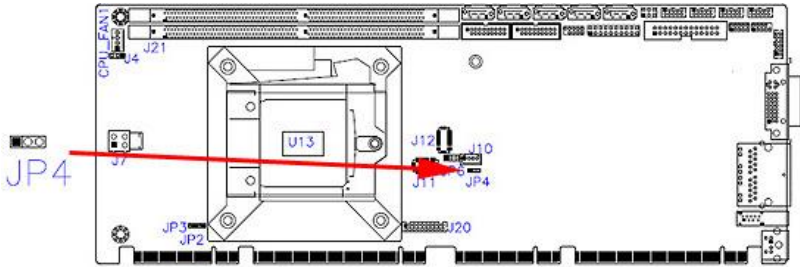

### 2.4.3 LVDS Power Brightness Selection (JP4)

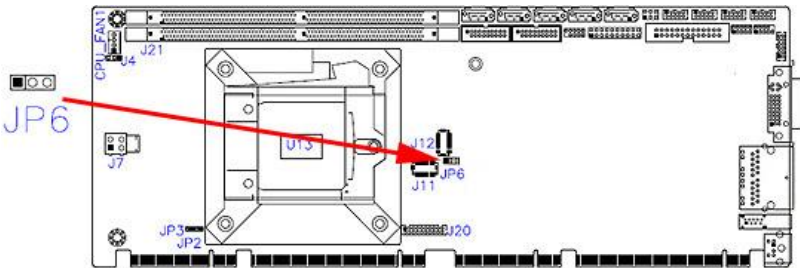

Function	Pin closed	Illustration
3.3V (default)	1-2	 1
5V	2-3	 1

### 2.4.4 LVDS Panel Power Selection (JP6)

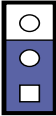

Function	Pin closed	Illustration
3.3V (default)	1-2	 1
5V	2-3	 1

### 2.4.5 Clear ME Register (JP8)

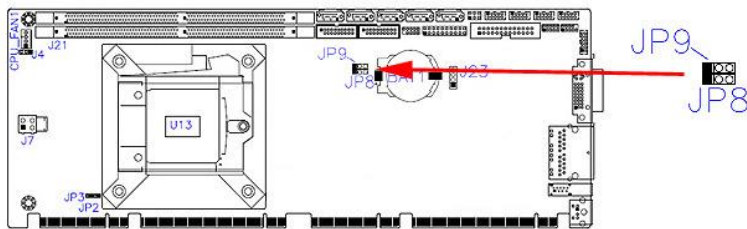

Function	Pin closed	Illustration
Normal (default)	1-2	1
Clear ME	2-3	1

### 2.4.6 Clear CMOS Data (JP9)

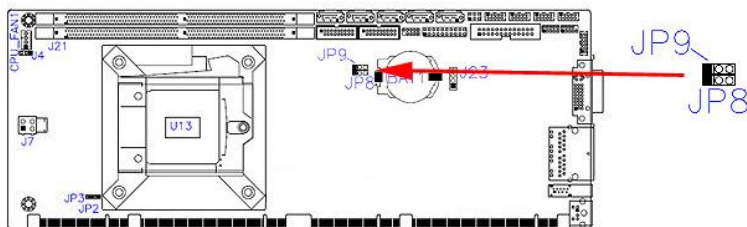

Function	Pin closed	Illustration
Normal (default)	1-2	1
Clear CMOS	2-3	1

## 2.5 Connectors Quick Reference

Function	Connector Name	Page
COM1 RS-232/422/485 Ports	J25	19
COM2~COM4 RS-232 Ports	J26 (COM2), J5 (COM3), J6 (COM4)	20
Digital I/O Connector	J2	21
LCD Backlight Connector	J10	21
ATX 12V Power Connector	J7	22
Dual USB 3.0 Pin-Header	J8,J9	23
Dual USB 2.0 Pin-Header	J16	24
Front Panel Audio Connector	J18	25
Front Panel Settings Connector	J3	25
LVDS Connector	J11, J12	26
Fan Power Connector	CPU_FAN1	27
DVI-D Connector	J20	28
Parallel Port	J24	29

### 2.5.1 COM1 RS-232/422/485 & COM2 RS-232 Serial Port (J25)

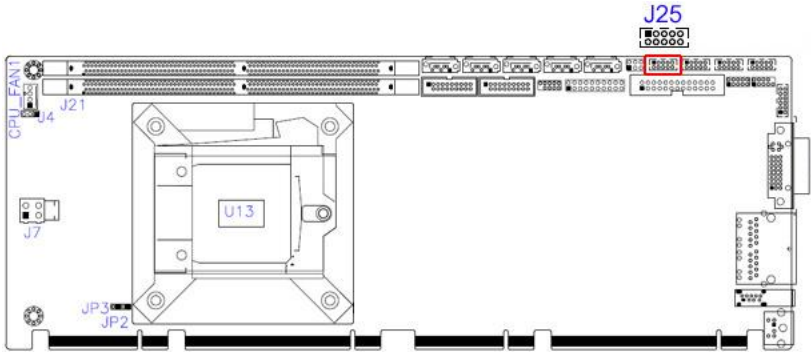

Pin	Signal Name	Pin	Signal Name
1	DCD, Data carrier detect	2	RXD, Receive data
3	TXD, Transmit data	4	DTR, Data terminal ready
5	Ground	6	DSR, Data set ready
7	RTS, Request to send	8	CTS, Clear to send
9	RI, Ring indicator	10	N/A

Pin	Signal Name		
	RS-232	RS-422	RS-485
1	DCD	TX-	DATA-
2	RX	TX+	DATA+
3	TX	RX+	NC
4	DTR	RX-	NC
5	Ground	Ground	Ground
6	DSR	NC	NC
7	RTS	NC	NC
8	CTS	NC	NC
9	RI	NC	NC

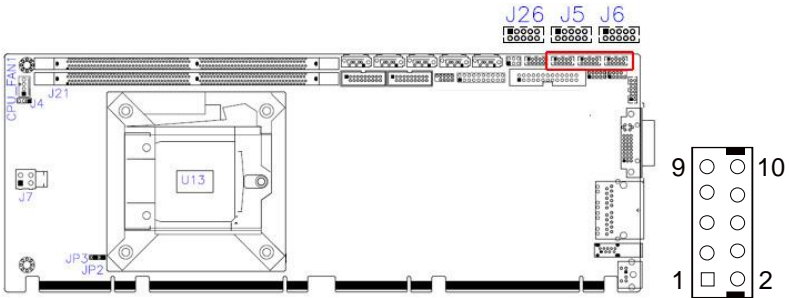
**2.5.2 COM2~COM4 RS-232 Ports (J26, J5, J6)**

Pin	Signal Name	Pin	Signal Name
1	DCD, Data carrier detect	2	RXD, Receive data
3	TXD, Transmit data	4	DTR, Data terminal ready
5	Ground	6	DSR, Data set ready
7	RTS, Request to send	8	CTS, Clear to send
9	RI, Ring indicator	10	Key

### 2.5.3 Digital I/O Connector (J2)

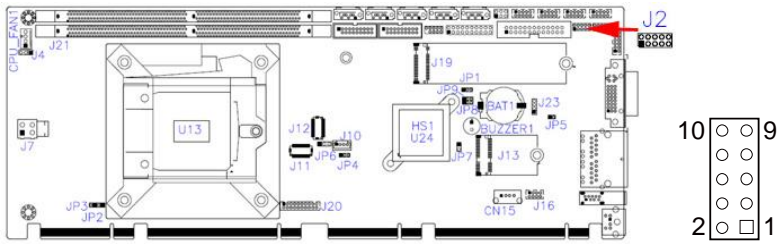

Pin	Signal Name	Pin	Signal Name
1	Ground	2	+5V
3	OUT3	4	OUT1
5	OUT2	6	OUT0
7	IN3	8	IN1
9	IN2	10	IN0

### 2.5.4 LCD Backlight Connector (J10)

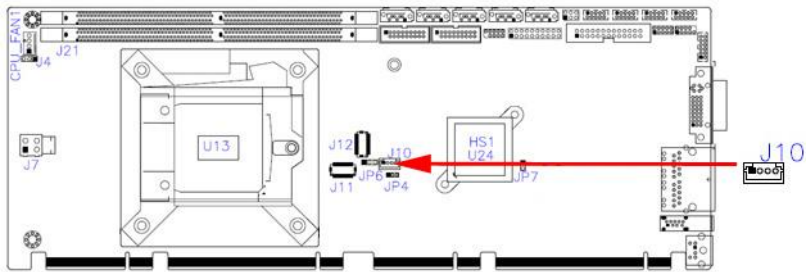

Pin	Signal Name	Pin	Signal Name
1	+12V	3	Brightness Control
2	Backlight Enable	4	Ground

## 2.5.5 ATX Power Connector (J7)

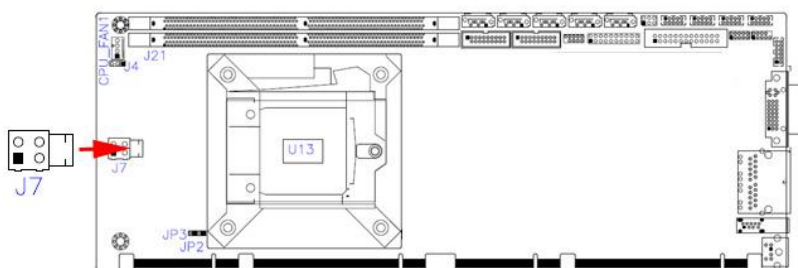

Pin	Assignment	Pin	Assignment
1	Ground	3	+12V
2	Ground	4	+12V

### 2.5.6 USB3.0/2.0 Connector (J8, J9)

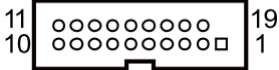
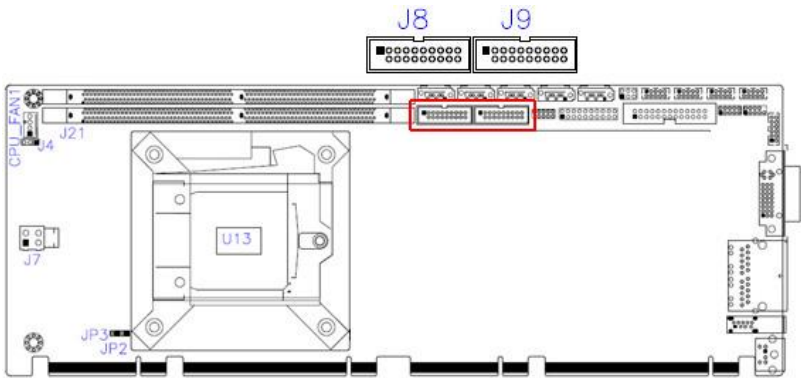

Pin #	Assignment	Pin #	Assignment
1	VCC(900mA)	11	P2_U2_D+
2	P1_SSRX-	12	P2_U2_D-
3	P1_SSRX+	13	GND
4	GND	14	P2_SSTX+
5	P1_SSTX-	15	P2_SSTX-
6	P1_SSTX+	16	GND
7	GND	17	P2_SSRX+
8	P1_U2_D-	18	P2_SSRX-
9	P1_U2_D+	19	VCC(900mA)
10	NC		

### 2.5.7 Dual USB 2.0 Connector (J16)

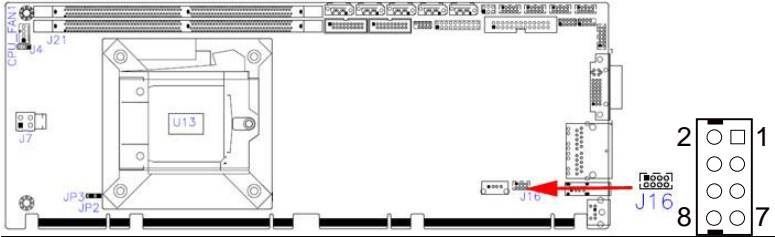

Pin	Signal Name	Pin	Signal Name
1	VCC	2	Ground
3	D0-	4	D1+
5	D0+	6	D1-
7	Ground	8	VCC

### 2.5.8 Front Panel Audio Connector (J18)

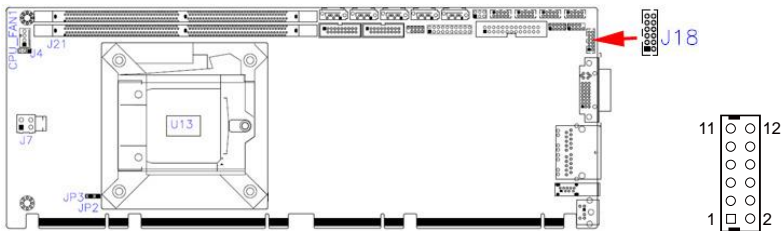

Pin	Signal Name	Pin	Signal Name
1	HPOUT_L	2	HPOUT_R
3	HPOUT_JD	4	Ground
5	LINE_L	6	LINE_R
7	LINE_JD	8	Ground
9	MIC IN_L	10	MIC IN_R
11	MIC IN_JD	12	Ground

### 2.5.9 Front Panel Settings Connector (J3)

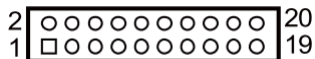
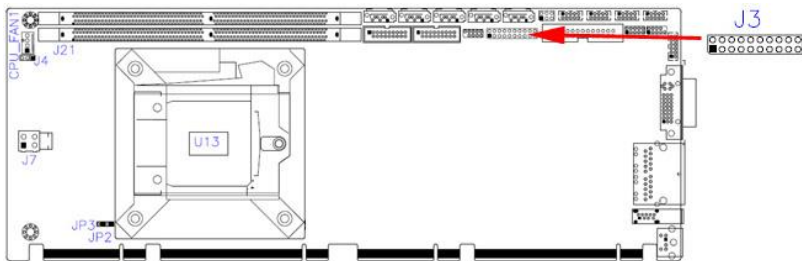

Pin	Signal Name	Pin	Signal Name
1	Power LED+	2	SPK
3	NC	4	NC
5	Power LED-	6	Ground
7	NC	8	SPK(VCC5)
9	Ground	10	NC
11	Ground	12	NC
13	Power BTN-	14	Power BTN+
15	NC	16	NC
17	Reset BTN-	18	Reset BTN+
19	HDD LED+	20	HDD LED-

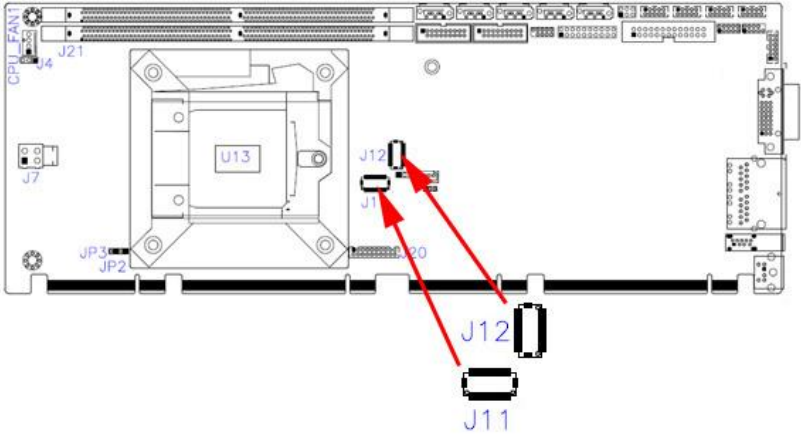
**2.5.10 LVDS Connector (J11, J12)**

Pin	Signal Name	Pin	Signal Name
1	TX0P	2	TX0N
3	Ground	4	Ground
5	TX1P	6	TX1N
7	Ground	8	Ground
9	TX2P	10	TX2N
11	Ground	12	Ground
13	CLKP	14	CLKN
15	Ground	16	Ground
17	TX3P	18	TX3N
19	VDD	20	VDD

*Remarks: J11 is 1st LVDS; J12 is 2nd LVDS.*

## 2.5.11 Fan Power Connector (CPU\_FAN1)

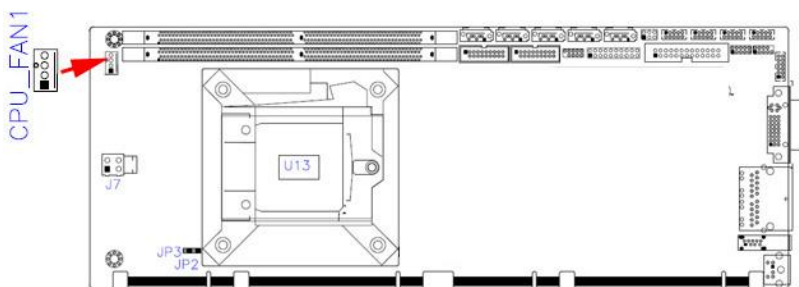

Pin	Signal Name	Pin	Signal Name
1	Ground	3	Rotation detection
2	+12V	4	Control

*Remarks: (PWM Mode Only)*

**2.5.12 DVI-D Connector (J20)**

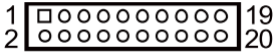
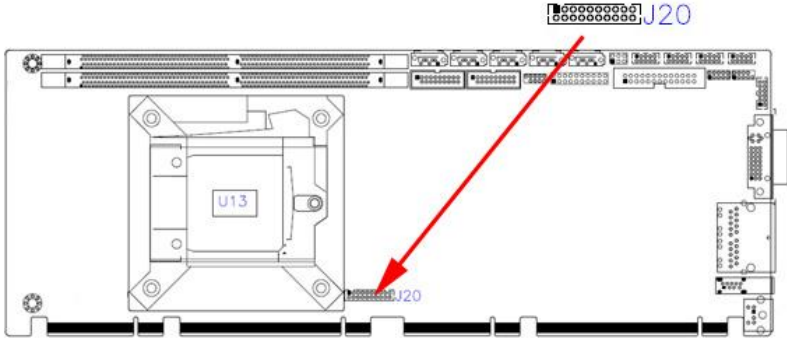

Pin	Signal Name	Pin	Signal Name
1	TMDS_DATA1_P	2	TMDS_DATA1_N
3	Ground	4	Ground
5	TMDS_CLK_P	6	TMDS_CLK_N
7	Ground	8	Ground
9	Hot Plug Detect	10	NC
11	TMDS_DATA2_P	12	TMDS_DATA2_N
13	Ground	14	Ground
15	TMDS_DATA0_P	16	TMDS_DATA0_N
17	NC	18	NC
19	TMDS_SDA	20	TMDS_SCL

### 2.5.13 Parallel Port (J24)

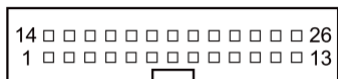
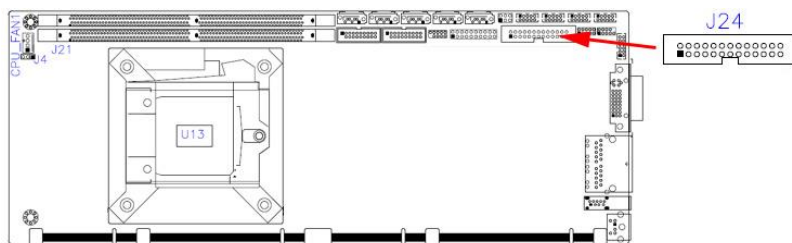

Pin	Signal Name	Pin	Signal Name
1	Line printer strobe	14	Auto Feed
2	PD0, parallel data 0	15	Error
3	PD1, parallel data 1	16	Initialize
4	PD2, parallel data 2	17	Select-Printer / Select-In
5	PD3, parallel data 3	18	Ground
6	PD4, parallel data 4	19	Ground
7	PD5, parallel data 5	20	Ground
8	PD6, parallel data 6	21	Ground
9	PD7, parallel data 7	22	Ground
10	ACK,acknowledge	23	Ground
11	Busy	24	Ground
12	Paper Empty	25	Ground
13	Select	26	Ground

This page is intentionally left blank.

# Chapter 3

## Drivers Installation

This chapter introduces installation of the following drivers:

- Intel® Chipset Software Installation Utility
- VGA Driver
- HD Audio Driver
- LAN Driver
- Intel® Management Engine Interface
- Intel® USB 3.0 Driver

### 3.1 Introduction

This section describes the installation procedures for software and  
The contents of this section include the following:

---

**Note:** After installing your Windows operating system, you must install first the Intel Chipset Software Installation Utility before proceeding with the drivers installation.

---

### 3.2 Intel® Chipset Software Installation Utility

The Intel® Chipset drivers should be installed first before the software drivers to install INF files for Plug & Play function for Intel chipset components. Follow the instructions below to complete the installation.

1. Go to the download page of the product. Copy the compressed drivers file to your computer. Double click the file to decompress it. Run “CDGuide” to go to the main drivers page as shown. Click **Intel** and then **Intel(R) Coffeelake Chipset Drivers**.



2. Click Intel(R) Chipset Software Installation Utility.



## iBASE

3. When the *Welcome* screen to the Intel® Chipset Device Software appears, click **Next** to continue.
4. Click **Accept** to accept the software license agreement and proceed with the installation process.
5. On the *Readme File Information* screen, click **Install**.

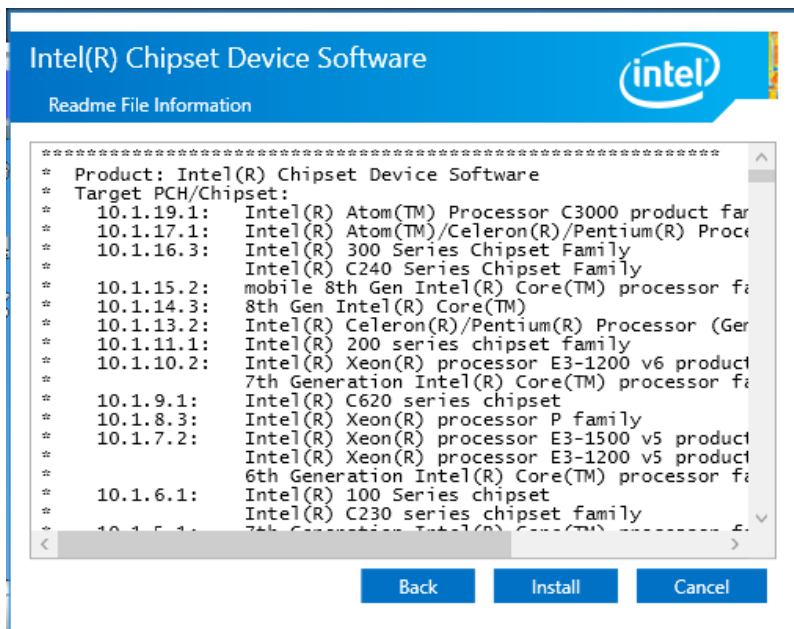

6. When installation is complete, click **Restart Now** to restart the computer and for changes to take effect.

### 3.3 VGA Driver Installation

1. Click **Intel** and then **Intel(R) Coffeelake Chipset Drivers**.

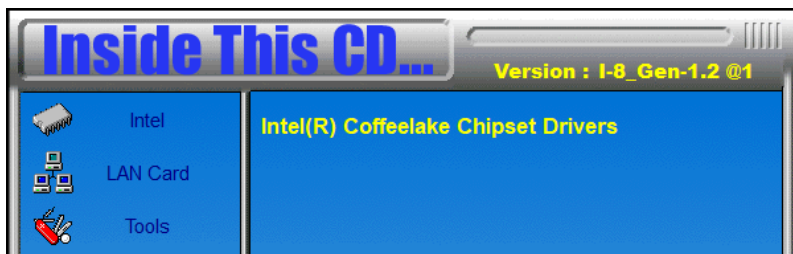

2. Click **Intel(R) HD Graphics Driver**.



3. When the *Welcome* screen appears, click **Next** to continue.

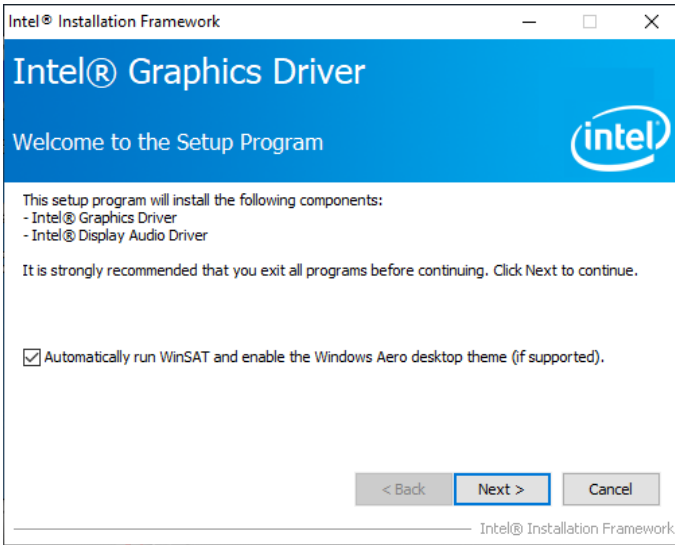

4. Click **Yes** to agree with the license agreement and continue the installation.

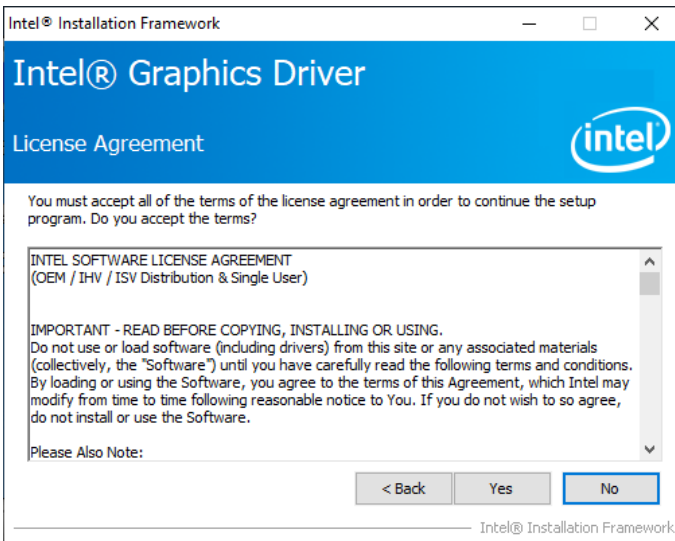

5. On the *Readme File Information* screen, click **Next** to continue.

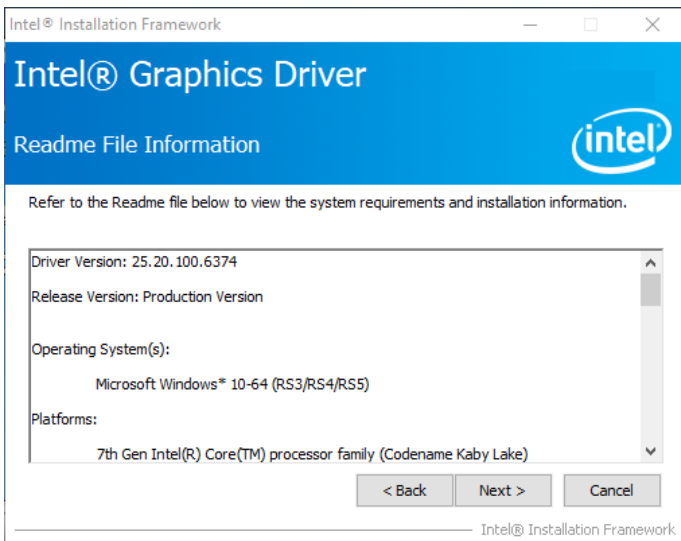

6. While Setup is in progress, click **Next** to continue.

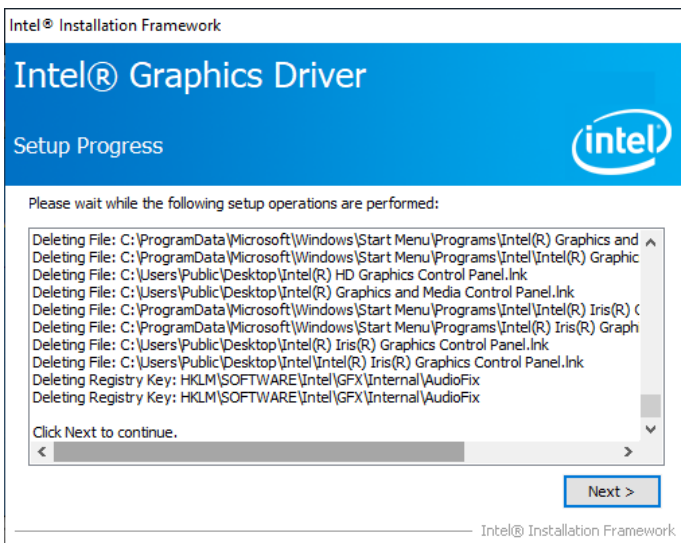

7. When installation is complete, click **Finish** to restart the computer and for changes to take effect.

### 3.4 HD Audio Driver Installation

1. Click **Intel** and then **Intel(R) Coffeelake Chipset Drivers**.



2. Click **Realtek High Definition Audio Driver**.



3. On the *Welcome* screen of the InstallShield Wizard, click **Next** to start the installation.
4. When installation is complete, click **Finish** to restart the computer and for changes to take effect.

### 3.5 LAN Driver Installation

1. Click **Intel** and then **Intel(R) Coffeelake Chipset Drivers**.

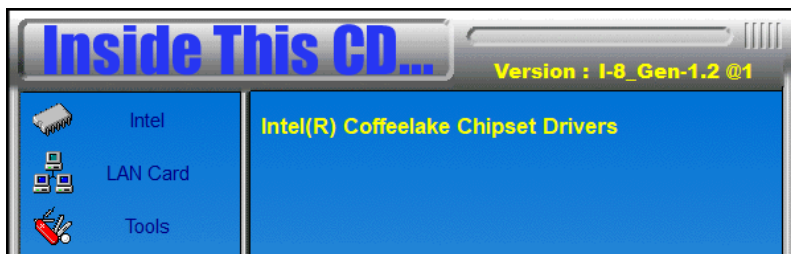

2. Click Intel(R) PRO LAN Network Drivers.



3. Click **Next** to accept the terms in the license agreement.

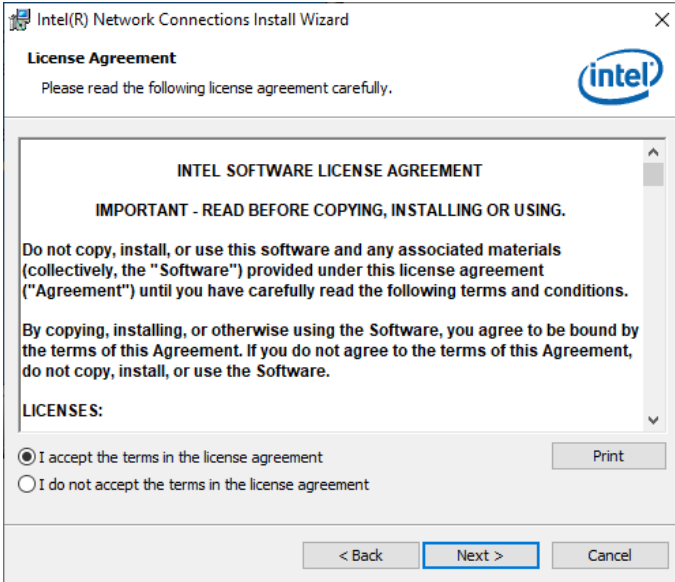

4. Click **Next** after checking the device drivers in the Setup options.

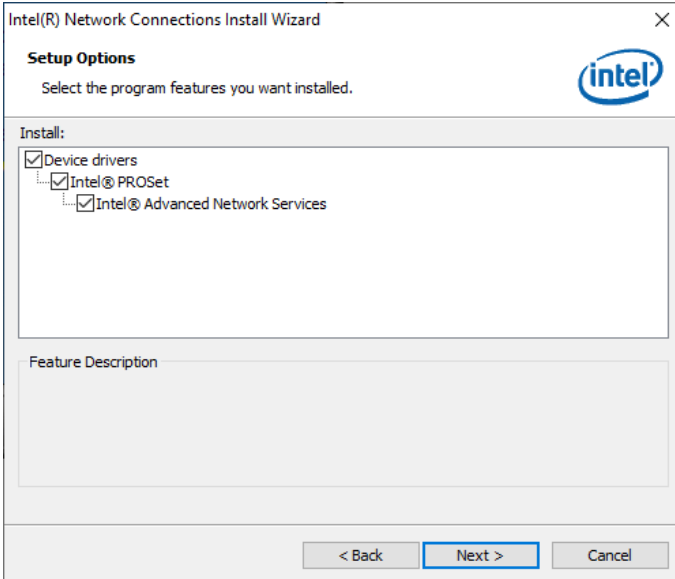

5. Click **Install** to continue.

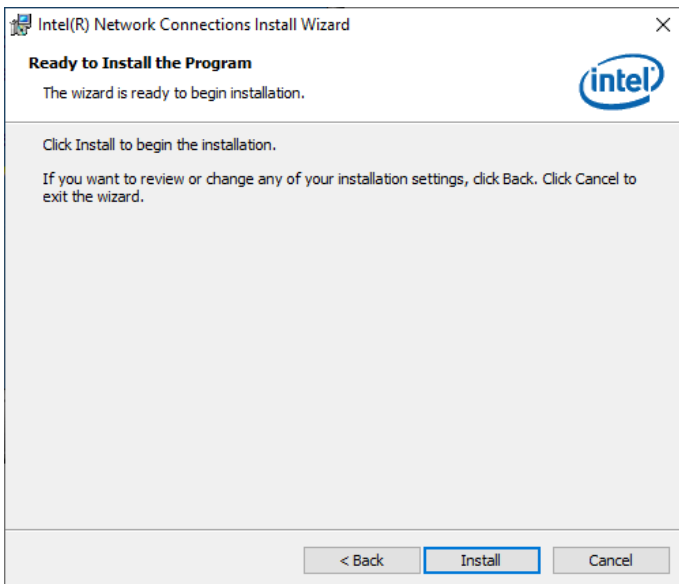

6. When Install wizard is completed, click **Finish**.

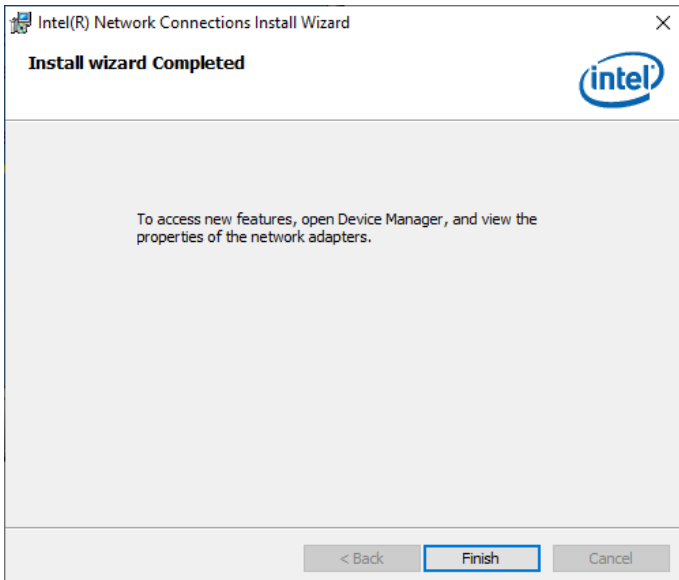

### 3.6 Intel® Management Engine Interface

1. Click **Intel** and then **Intel(R) Coffeelake Chipset Drivers**.



2. Click **Intel(R) ME 12.x Drivers**.



- When the *Welcome* screen appears, click **Next**.

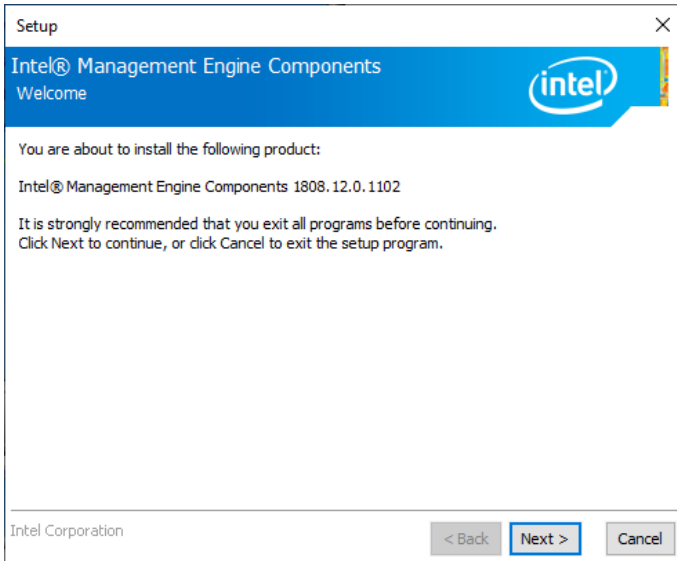

- Then next window shows the destination folder where to install the files. Click **Next**.

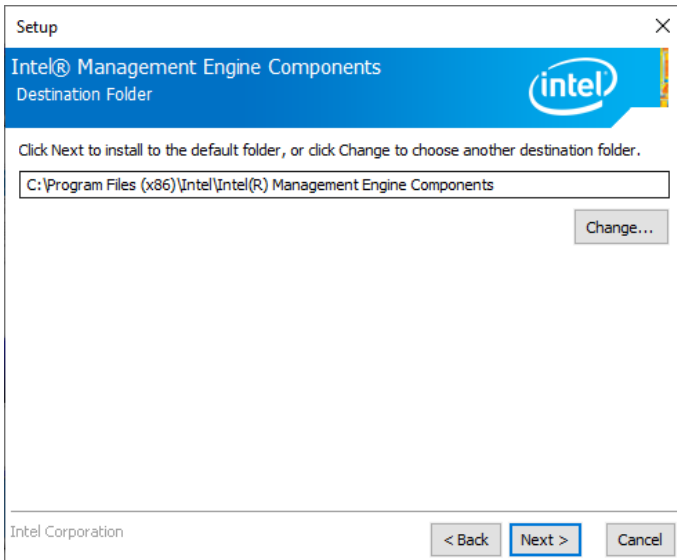

5. After the Intel® Management Engine Components have been installed, click **Finish**.

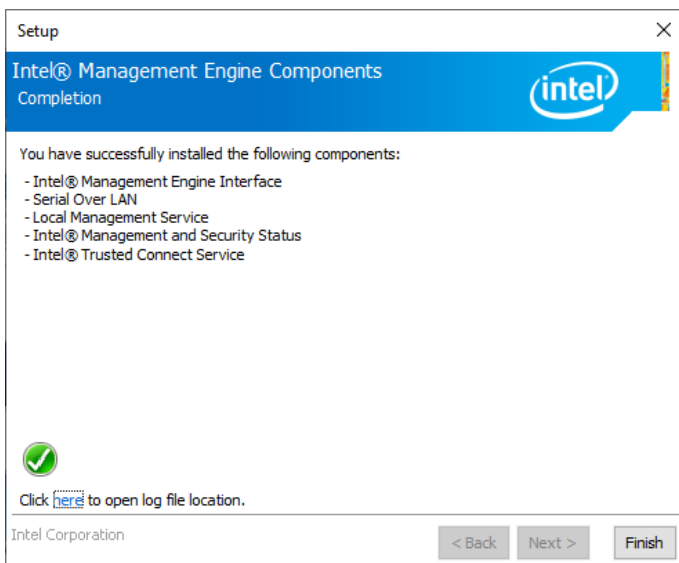

# Chapter 4

## BIOS Setup

This chapter describes the different settings available in the AMI BIOS that comes with the board. The topics covered in this chapter are as follows:

- Main Settings
- Advanced Settings
- Chipset Settings
- Security Settings
- Boot Settings
- Save & Exit

## 4.1 Introduction

The BIOS (Basic Input/Output System) installed in the ROM of your computer system supports Intel® processors. The BIOS provides critical low-level support for standard devices such as disk drives, serial ports and parallel ports. It also provides password protection as well as special support for detailed fine-tuning of the chipset controlling the entire system.

## 4.2 BIOS Setup

The BIOS provides a Setup utility program for specifying the system configurations and settings. The BIOS ROM of the system stores the Setup utility. When you turn on the computer, the BIOS is immediately activated. Pressing the <Del> key immediately allows you to enter the Setup utility. If you are a little bit late pressing the <Del> key, POST (Power On Self Test) will continue with its test routines, thus preventing you from invoking the Setup.

If you still need to enter Setup, restart the system by pressing the "Reset" button or simultaneously pressing the <Ctrl>, <Alt> and <Delete> keys.

You can also restart by turning the system Off and back On again.

The following message will appear on the screen:

```
Press <DEL> to Enter Setup
```

In general, press the arrow keys to highlight items, <Enter> to select, the <PgUp> and <PgDn> keys to change entries, <F1> for help, and <Esc> to quit.

When you enter the BIOS Setup utility, the *Main Menu* screen will appear on the screen. The Main Menu allows you to select from various setup functions and exit choices.

---

**Warning:** It is strongly recommended that you avoid making any changes to the chipset defaults.

These defaults have been carefully chosen by both AMI and your system manufacturer to provide the absolute maximum performance and reliability. Changing the defaults could make the system unstable and crash in some cases.

---

## 4.3 Main Settings

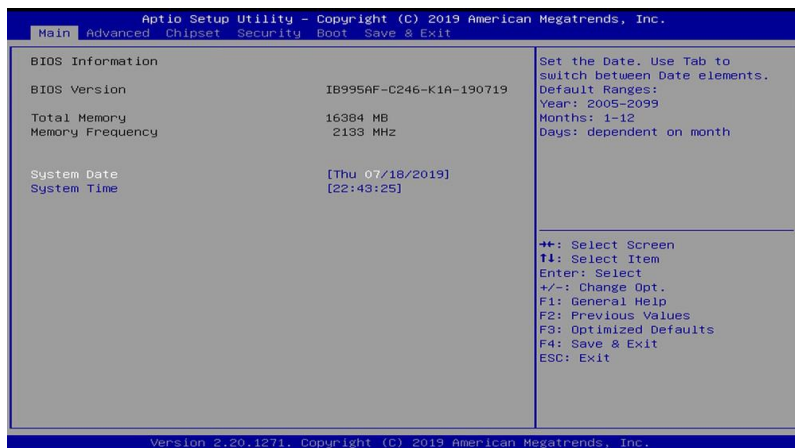

BIOS Setting	Description
System Date	Sets the date. Use the <Tab> key to switch between the DATE elements.
System Time	Set the time. Use the <Tab> key to switch between the TIME elements.

## 4.4 Advanced Settings

This section allows you to configure, improve your system and allows you to set up some system features according to your preference.

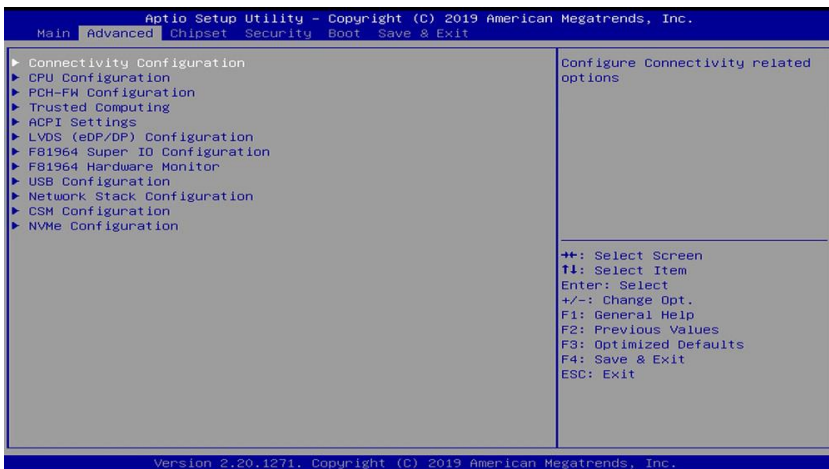

### 4.4.1 Connectivity Configuration

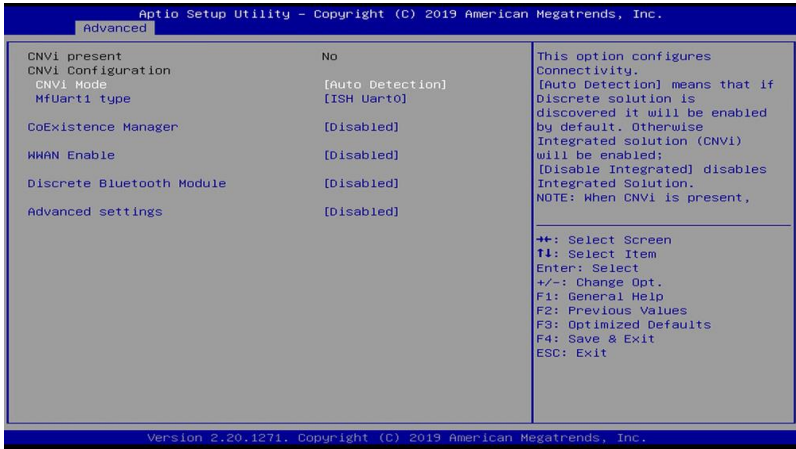

BIOS Setting	Description
CNVi Mode	This option configures Connectivity [Auto Detection] means that if Discrete solution is discovered it will be enabled by default. Otherwise Integrated solution (CNVi) will be enabled; [Disable Integrated] disables integrated solution.
CNVi Mode	This option configures Connectivity [Auto Detection] means that if Discrete solution is discovered it will be enabled by default. Otherwise integrated solution (CNVi) will be enabled; [Disable Integrated] disables integrated solution.
MfUart1 type	This is a test option which allows configuration of UART type for WiFi side band communication. Options are ISH Uart0, SerialIO Uart2, Uart over external pads, Not connected.
CoExistence Manager	CoEx Manager mitigates radio coexistence issues between Intel WWAN (modem) and Intel WLAN (WiFi/BT). This should be enabled only if both WWAN and WLAN solutions are based on Intel components.
WWAN Enable	Enables/Disables M.2 WWAN module. WWAN can only be enabled for re-work board.
Discrete Bluetooth Module	SerialIO UART0 needs to be enabled to select BT Module
Advanced settings	Configure ACPI objects for wireless devices

## 4.4.2 CPU Configuration

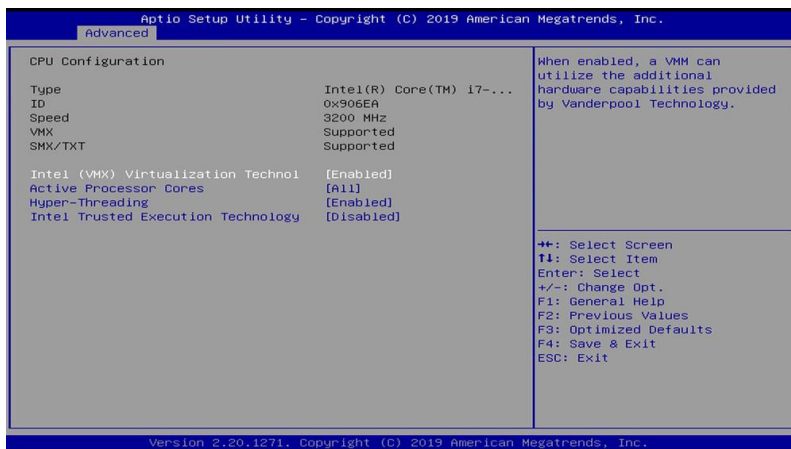

BIOS Setting	Description
Intel (VMX) Virtualization Techno1	When enabled, a VMM can utilize the additional hardware capabilities provided by Vanderpool Technology
Active Processor Cores	Number of cores to enable in each processor package. Options are All, 1, 2, 3, 4, 5
Hyper-Threading	Enabled for Windows XP and Linux (OS optimized for Hyper-Threading Technology) and Disabled for other OS (OS not optimized for Hyper-Threading Technology).
Intel Trusted Execution Technology	Enables utilization of additional hardware capabilities provided by Intel® Trusted Execution Technology. Changes require a full power cycle to take effect.

### 4.4.3 PCH-FW Configuration

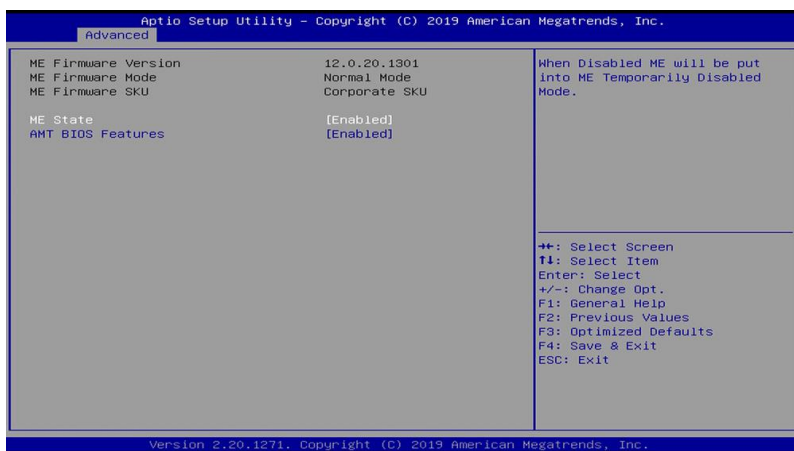

BIOS Setting	Description
ME State	When disabled, ME will be put into ME Temporarily Disabled Mode
AMT BIOS Features	When disabled, AMT BIOS features are no longer supported and user is no longer able to access MEBx Setup.

### 4.4.4 Trusted Computing

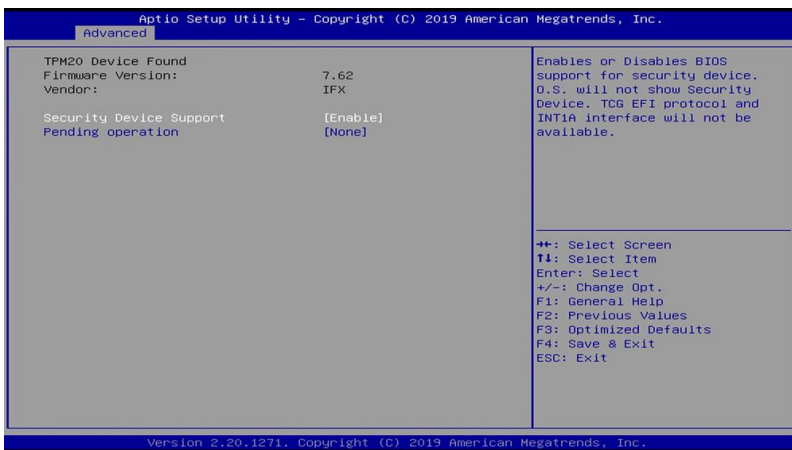

BIOS Setting	Description
Security Device Support	Enables / Disables BIOS support for security device. OS will not show security device. TCG EFI protocol and INT1A interface will not be available.
Pending Operation	Schedule an operation for the Security Device. NOTE: Your computer will reboot during restart in order to chnge State of Security Device.

## 4.4.5 ACPI Settings

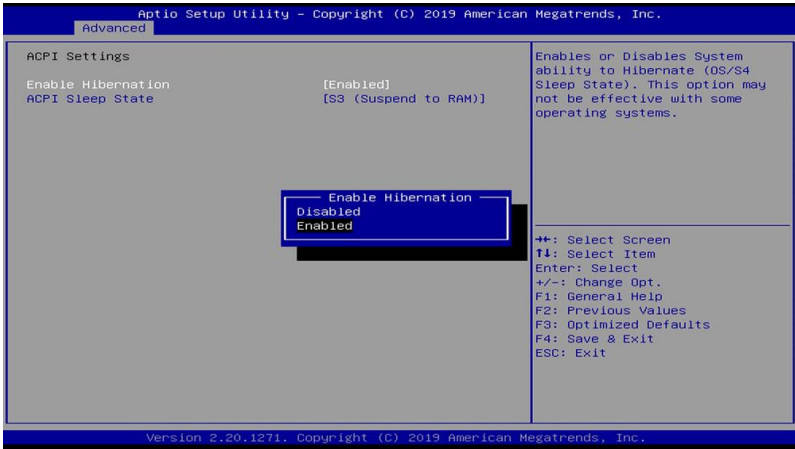

BIOS Setting	Description
Enable Hibernation	Enables / Disables the system ability to hibernate (OS/S4 Sleep State). This option may be not be effective with some operating systems.
ACPI Sleep State	Selects the highest ACPI sleep state the system will enter when the suspend button is pressed. Options: Suspend Disabled, S3 (Suspend to RAM)

### 4.4.6 LVDS (eDP/DP) Configuration

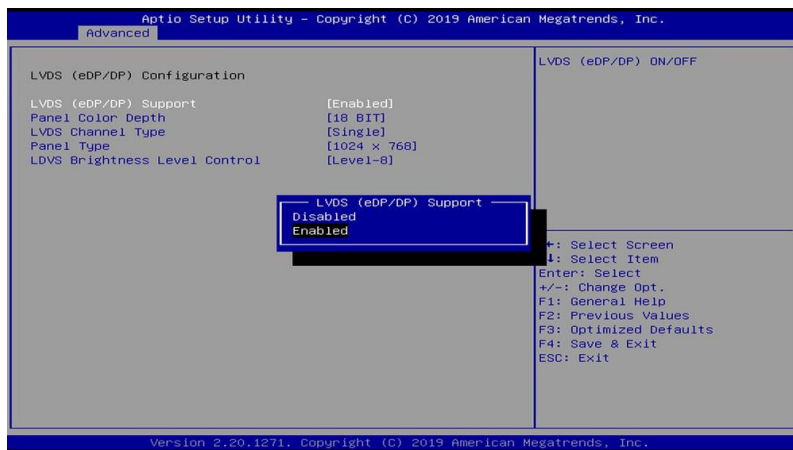

BIOS Setting	Description
LVDS (eDP/DP) Support	LVDS (eDP/DP) ON/OFF
Panel Color Depth	Options: 18 BIT, 24bit(VESA), 24bit(JEIDA)
LVDS Channel Type	Options: Single, Dual
Panel Type	Options: 800x480, 800x600, 1024x768, 1280x768, 1280x800, 1280x960, 1280x1024, 1366x768, 1440x900, 1600x900, 1600x1200, 1680x1050, 1920x1080, 1920x1200
LVDS Brightness Level Control	Options: Level-1, Level-2, Level-3, Level -4, Level-5, Level-6, Level-7, Level-8

## 4.4.7 F81964 Super IO Configuration

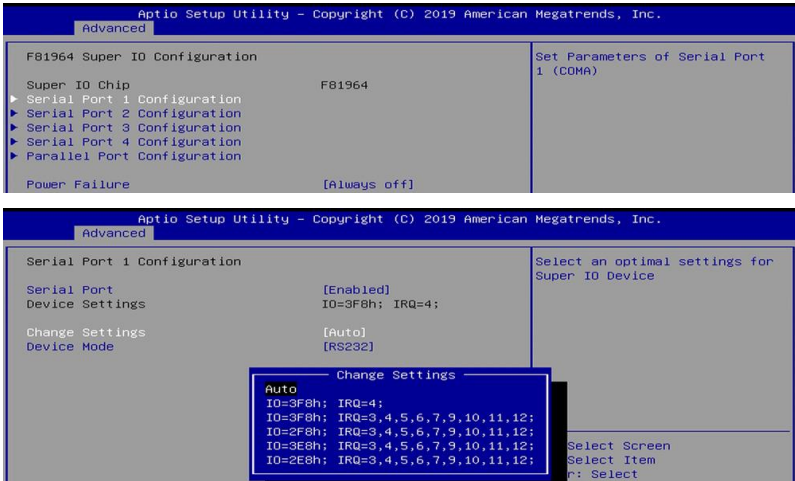

BIOS Setting	Description
Serial Port Configuration	Sets parameters of serial ports. Enables / Disables the serial port and select an optimal setting for the Super IO device.
Parallel Port Configuration	Set parameters of parallel port (LPT/LPTE)
Power Failure	Options: Always on, Always off

### 4.4.8 F81964 Hardware Monitor

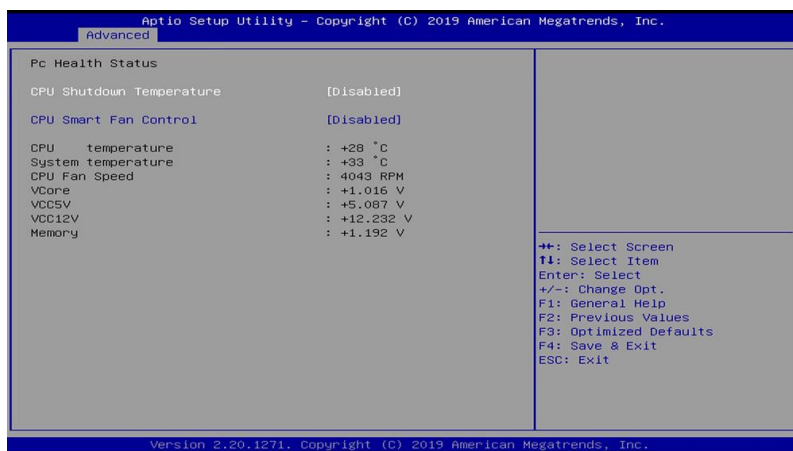

BIOS Setting	Description
CPU Shutdown Temperature	Options: Disabled / 70 °C / 75 °C / 80 °C / 85 °C / 90 °C / 95 °C
CPU Smart Fan Control	Enables / Disables the CPU smart fan feature. Options: Disabled / 50 °C / 60 °C / 70 °C / 80 °C
Temperatures / Voltages	These fields are the parameters of the hardware monitoring function feature of the motherboard. The values are read-only values as monitored by the system and show the PC health status.

## 4.4.9 USB Configuration

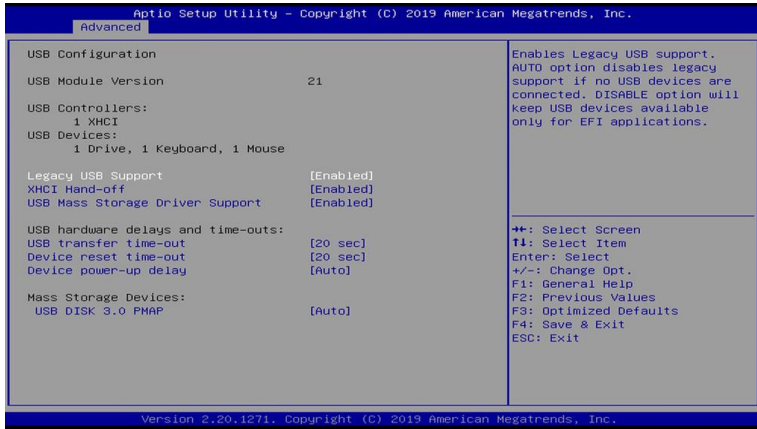

BIOS Setting	Description
Legacy USB Support	Enables Legacy USB support. "Auto" disables legacy support if there is no USB device connected. "Disable" keeps USB devices available only for EFI applications.
XHCI Hand-off	This is a workaround for OSeS without XHCI hand-off support. The XHCI ownership change should be claimed by XHCI driver.
USB Mass Storage Driver Support	Enables / Disables the support for USB mass storage driver.
USB Transfer time-out	The time-out value for Control, Bulk, and Interrupt transfers.
Device reset time-out	USB mass storage device start unit command time-out. Options: 10/20/30/40 sec
Device power-up delay	Maximum time the device will take before it properly reports itself to the Host Controller. 'Auto' uses default value: for a Root port it is 100 ms, for a Hub port the delay is taken from Hub descriptor
USB Disk 3.0 PMAP	Mass storage device emulation type. 'Auto' enumerates devices according to their media format. Optical drives are emulated as 'CDROM', drives with no media will be emulated according to a drive type

### 4.4.10 Network Stack Configuration

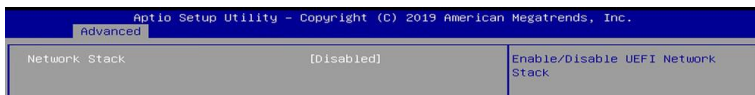

BIOS Setting	Description
Network Stack	Enable/Disable UEFI Network Stack

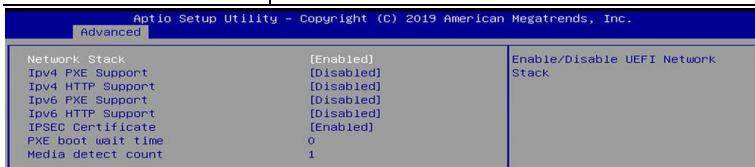

BIOS Setting	Description
Ipv4 PXE Support	Enable/Disable IPv4 PXE boot support. If disabled, IPv4 PXE boot support will not be available
Ipv4 HTTP Support	Enable/Disable IPv4 HTTP boot support. If disabled, IPv4 HTTP boot support will not be available
Ipv4 PXE Support	Enable/Disable IPv4 PXE boot support. If disabled, IPv4 PXE boot support will not be available
Ipv6 HTTP Support	Enable/Disable IPv6 HTTP boot support. If disabled, IPv4 HTTP boot support will not be available
Ipv6 PXE Support	Enable/Disable IPv6 PXE boot support. If disabled, IPv4 PXE boot support will not be available
IPSEC Certificate	Support to Eable/Disable IPSEC certificate for lkey.
PXE boot wait time	Wait time in seconds to press ESC key to aboart the PXE boot. Use either +/- or numeric keys to set the value
Media detect count	Number of times the presence of media will be checked. Use either +/- or numeric keys to set the value

### 4.4.11 CSM Configuration

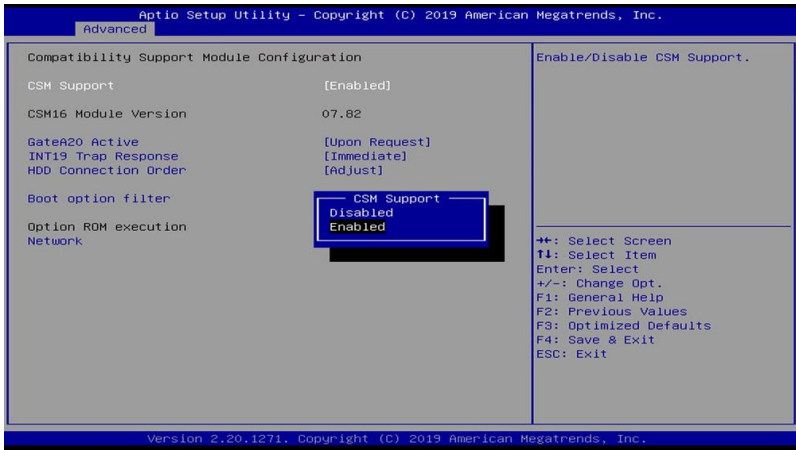

BIOS Setting	Description
CSM Support	Enables / Disables CSM support.
GateA20 Active	UPON REQUEST – GA20 can be disable using BIOS services. ALWAYS – do not allow disabling GA20; this option is useful when any RT code is executed above 1MB.
INT19 Trap Response	BIOS reaction on INT19 trapping by option ROM: IMMEDIATE - execute the trap right away; POSTPONED – execute the trap during legacy boot.
HDD Connection Order	Some OS require HDD handles to be adjusted, i.e. OS is installed on drive 80h.
Boot option filter	This option controls Legacy/UEFI ROMs priority Options: UEFI and Legacy / Legacy only / UEFI only
Network	Controls the execution of UEFI and Legacy PXE OpROM. Options: Do not launch / Legacy

## 4.4.12 NVMe Configuration

This sets the NVMe Device Options.

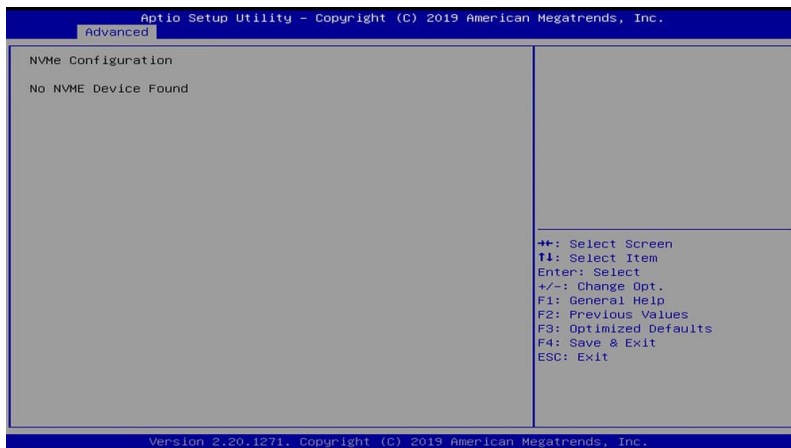

## 4.5 Chipset Settings

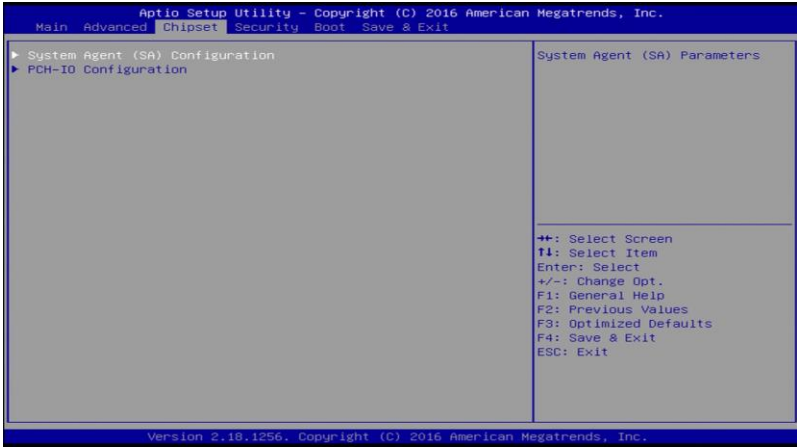

BIOS Setting	Description
System Agent (SA) Configuration	System Agent (SA) parameters
PCH-IO Configuration	PCH parameters

## 4.5.1 System Agent (SA) Configuration

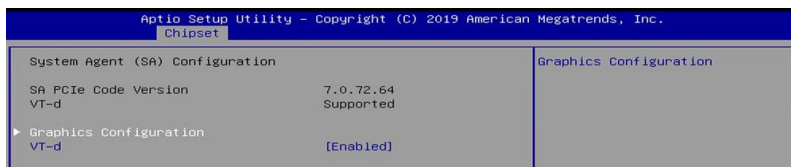

### 4.5.1.1 Graphics Configuration and VT-d Capability

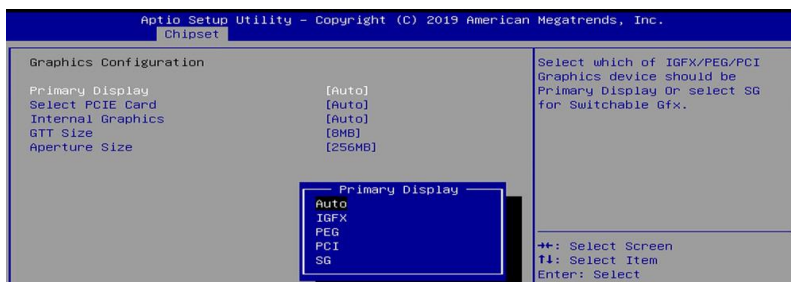

BIOS Setting	Description
Primary Display	Selects which of IGFX/PEG/PCI graphics device should be primary display, or selects SG for switchable Gfx.
Select PCIe Card	Select the card used on the platform. Auto: Skip GPIO based Power Enable to dGPU Elk Creek 4: DGPU Power Enable = ActiveLow PEG Eval: DGPU Power Enable = ActiveHigh
Internal Graphics	Keeps IGFX enabled based on the setup options.
GTT Size	Select the GTT Size Options: 2MB / 4MB / 8MB
Aperture Size	Select the Aperture Size Note: Above 4MB MMIO BIOS assignment is automatically enabled when selecting 2048MB aperture. To use this feature, please disable CSM Support. Options: 128MB / 256MB / 512MB / 1024MB / 2048MB

## 4.5.2 PCH-IO Configuration



BIOS Setting	Description
SATA and RST Configuration	Configures SATA devices.
PCH LAN Controller	Enables / Disables the onboard NIC.
Wake on LAN Enable	Enables / Disables the integrated LAN to wake up the system.

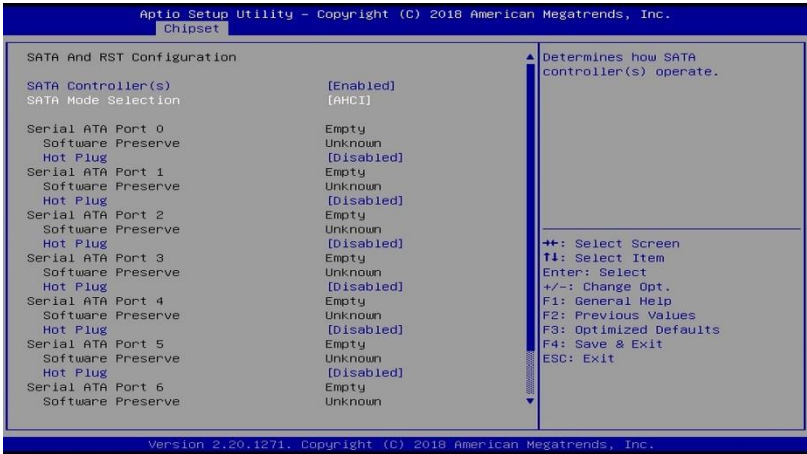

## 4.6 Security Settings

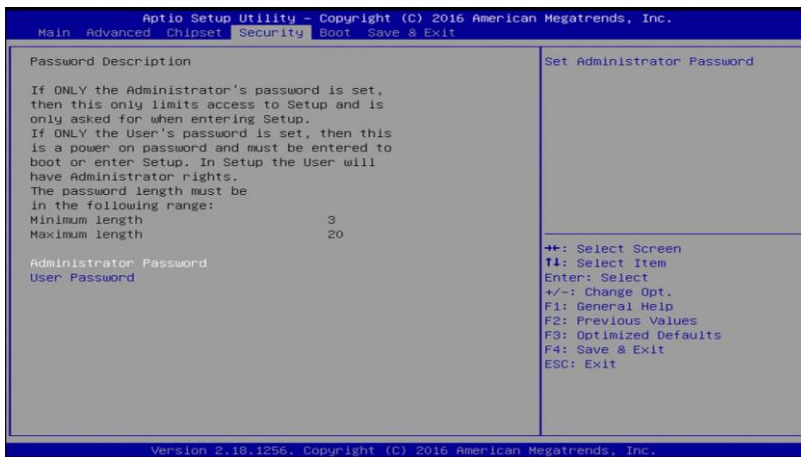

BIOS Setting	Description
Administrator Password	Sets an administrator password for the setup utility.
User Password	Sets a user password.

## 4.6.1 Secure Boot Configuration

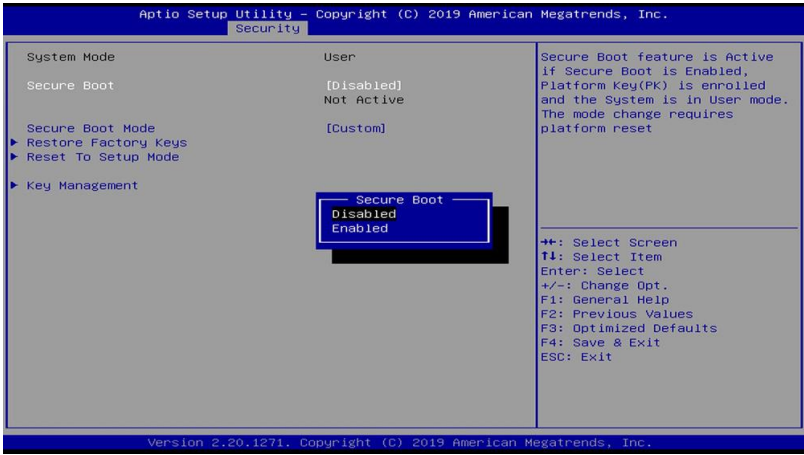

BIOS Setting	Description
Secure Boot	Secure Boot feature is active if Secure Boot enabled. Platform Key(PK) is enrolled and the system is in user mode. The mode change requires platform reset.
Secure Boot Mode	Secure Boot mode options: Standard or Custom. In Custom mode, Secure Boot Policy variables can be configured by a physically present user without full authentication.
Restore Factory Keys	Force System to User Mode. Install factory default Secure Boot key databases.
Reset To Setup Mode	Delete all Secure Boot key databases from NVRAM
Key Management	Enables expert users to modify Secure Boot Policy variables without full authentication

### 4.6.1.1 Key Management

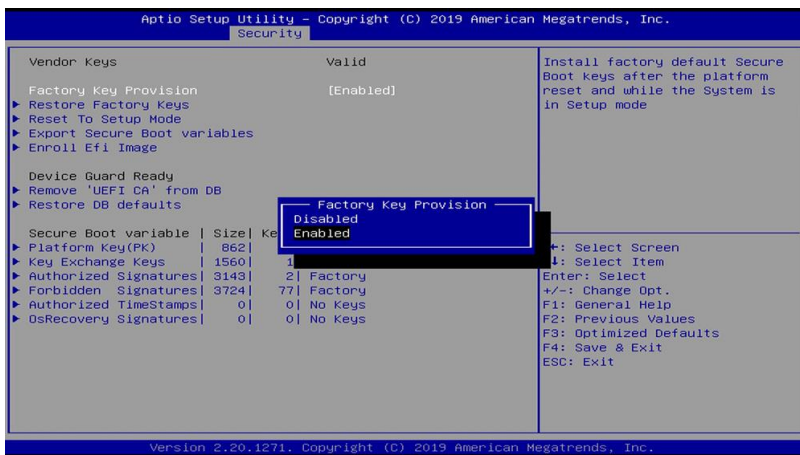

BIOS Setting	Description
Factory Key Provision	Install factory default Secure Boot keys after the platform reset and while the System is in Setup mode.
Restore Factory Keys	Force System to User Mode. Install factory default Secure Boot key databases.
Reset To Setup Mode	Delete all Secure Boot key databases from NVRAM
Export Secure Boot variables	Copy NVRAM content of Secure Boot variables to files in a root folder on a file system device
Enroll Efi Image	Allow the image to run in Secure Boot mode. Enroll SHA256 Hash certificate of a PE image into Authorized Signature Database(db)
Remove 'UEFI CA' from DB	Device Guard ready system must not list 'Microsoft UEFI CA' Certificate in Authorized Signature database (db)
Restore DB defaults	Restore DB defaults to factory defaults

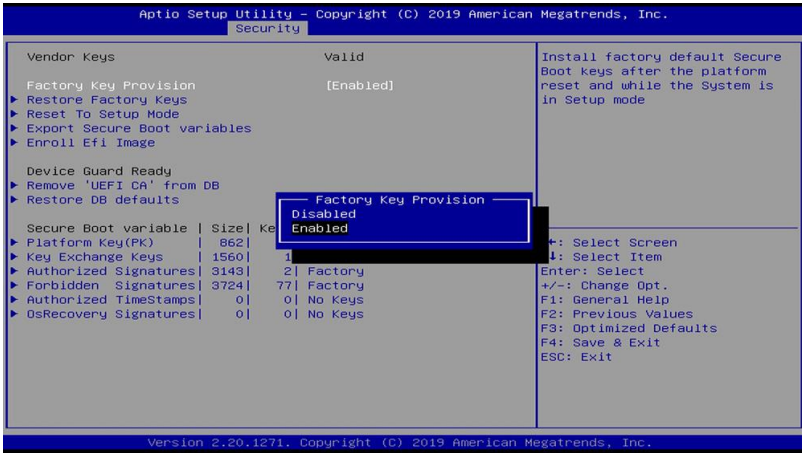

<p>Secure Boot variable</p> <p>Platform Key(PK)</p> <p>Key Exchange Keys</p> <p>Authorized Signatures</p> <p>Forbidden Signatures</p> <p>Authorized TimeStamps</p> <p>OsRecovery Signatures</p>	<p>Enroll Factory Defaults or load certificates from a file:</p> <ol style="list-style-type: none"> <li>1. Public Key Certificate:             <ol style="list-style-type: none"> <li>a) EFI_SIGNATURE_LIST</li> <li>b) EFI_CERT_X509 (DER)</li> <li>c) EFI_CERT_RSA2048 (bin)</li> <li>d) EFI_CERT_SHAXXX</li> </ol> </li> <li>2. Authenticated UEFI Variable</li> <li>3. EFI PE/COFF Image(SHA256)</li> </ol> <p>Key Source:</p> <p>Factory, External, Mixed</p>
---	--

## 4.7 Boot Settings

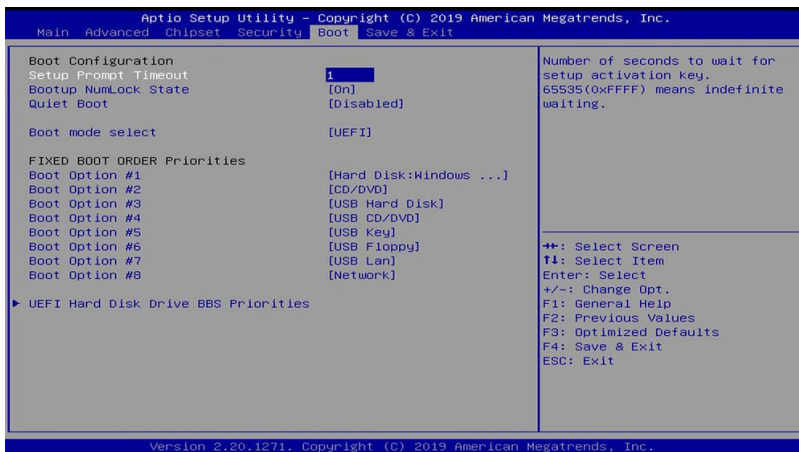

BIOS Setting	Description
Setup Prompt Timeout	Number of seconds to wait for setup activation key. 65535(0xFFFF) means indefinite waiting.
Bootup NumLock State	Selects the keyboard NumLock state.
Quiet Boot	Enables / Disables Quiet Boot option.
Boot mode select	Select boot mode LEGACY/UEFI
FIXED BOOT ORDER Priorities	Sets the system boot order.
UEFI Hardk Disk Drive BBS Priorities	Specifies the Boot Device Priority UEFI Hard Disk Drives

## 4.8 Save & Exit Settings



BIOS Setting	Description
Save Changes and Exit	Exits system setup after saving the changes.
Discard Changes and Exit	Exits system setup without saving any changes.
Save Changes and Reset	Resets the system after saving the changes.
Discard Changes and Reset	Resets system setup without saving any changes.
Save Changes	Saves changes done so far to any of the setup options.
Discard Changes	Discards changes done so far to any of the setup options.
Restore Defaults	Restores / Loads defaults values for all the setup options.
Save as User Defaults	Saves the changes done so far as User Defaults.
Restore User Defaults	Restores the user defaults to all the setup options.

# Appendix

This section provides the mapping addresses of peripheral devices and the sample code of watchdog timer configuration.

## A. I/O Port Address Map

Each peripheral device in the system is assigned a set of I/O port addresses which also becomes the identity of the device. The following table lists the I/O port addresses used.

Address	Device Description
0000h-0CF7h	PCI Express Root Complex
0040h-0043h	System timer
0050h-0053h	System timer
0070h-0070h	System CMOS/real time clock
00F0h-00F0h	Numeric data processor
02E8h-02EFh	Communications Port (COM4)
02F8h-02FFh	Communications Port (COM2)
03B0h-03BBh	Intel(R) HD Graphics 530
03C0h-03DFh	Intel(R) HD Graphics 530
03E8h-03EFh	Communications Port (COM3)
03F8h-03FFh	Communications Port (COM1)
0D00h-FFFFh	PCI Express Root Complex
E000h-0E01h	Intel(R) 100 Series/C230 Series Chipset Family PCI Express Root Port #6 - A115
F000h-F03Fh	Intel(R) HD Graphics 530
F040h-F05Fh	Intel(R) 100 Series/C230 Series Chipset SMBus - A123
F060h-F07Fh	Standard SATA AHCI Controller
F080h-F083h	Standard SATA AHCI Controller
F090h-F097h	Standard SATA AHCI Controller
F0A0h-F0A7h	Intel(R) Active Management Technology - SOL (COM5)

## B. Interrupt Request Lines (IRQ)

Peripheral devices use interrupt request lines to notify CPU for the service required. The following table shows the IRQ used by the devices on board.

Level	Function
IRQ0	System Timer
IRQ3	Serial Port #2
IRQ4	Serial Port #1
IRQ5	Serial Port #3
IRQ7	Serial Port #4
IRQ8	Real Time Clock
IRQ 11	Intel(R) 100 Series/C230 Series Chipset Family Integrated Sensor Hub - A135
IRQ 11	Intel(R) 100 Series/C230 Series Chipset SMBus - A123
IRQ 11	Intel(R) 100 Series/C230 Series Chipset Thermal subsystem - A131
IRQ 13	Numeric data processor
IRQ 16	High Definition Audio Controller
IRQ 16	Standard SATA AHCI Controller
IRQ 19	Intel(R) Active Management Technology - SOL (COM5)

## C. Watchdog Timer Configuration

The Watchdog Timer (WDT) is used to generate a variety of output signals after a user programmable count. The WDT is suitable for use in the prevention of system lock-up, such as when software becomes trapped in a deadlock. Under these sorts of circumstances, the timer will count to zero and the selected outputs will be driven.

Under normal circumstance, you will need to restart the WDT at regular intervals before the timer counts to zero.

### Sample Code:

```
//-----
//
// THIS CODE AND INFORMATION IS PROVIDED "AS IS" WITHOUT WARRANTY OF ANY
// KIND, EITHER EXPRESSED OR IMPLIED, INCLUDING BUT NOT LIMITED TO THE
// IMPLIED WARRANTIES OF MERCHANTABILITY AND/OR FITNESS FOR A PARTICULAR
// PURPOSE.
//
//-----
#include <dos.h>
#include <conio.h>
#include <stdio.h>
#include <stdlib.h>
#include "F81866.H"
//-----
int main (int argc, char *argv());
void EnableWDT(int);
void DisableWDT(void);
//-----
int main (int argc, char *argv())
{
    unsigned char bBuf;
    unsigned char bTime;
    char **endptr;

    char SIO;

    printf("Fintek 81866 watch dog program\n");

    SIO = Init_F81866();
    if (SIO == 0)
    {
        printf("Can not detect Fintek 81866, program abort.\n");
        return(1);
    }
    }/if (SIO == 0)

    if (argc != 2)
    {
        printf(" Parameter incorrect!\n");
        return (1);
    }

    bTime = strtol (argv(1), endptr, 10);
    printf("System will reset after %d seconds\n", bTime);

    if (bTime)
    {
        EnableWDT(bTime);
    }
    else
    {
        DisableWDT();
    }
}
```

```

        return 0;
    }
}
//-----
void EnableWDT(int interval)
{
    unsigned char bBuf;

    bBuf = Get_F81866_Reg(0x2B);
    bBuf &= (~0x20);
    Set_F81866_Reg(0x2B, bBuf);           //Enable WDTO

    Set_F81866_LD(0x07);
    //switch to logic device 7
    Set_F81866_Reg(0x30, 0x01);         //enable timer

    bBuf = Get_F81866_Reg(0xF5);
    bBuf &= (~0x0F);
    bBuf |= 0x52;
    Set_F81866_Reg(0xF5, bBuf);         //count mode is second

    Set_F81866_Reg(0xF6, interval);     //set timer

    bBuf = Get_F81866_Reg(0xFA);
    bBuf |= 0x01;
    Set_F81866_Reg(0xFA, bBuf);         //enable WDTO output

    bBuf = Get_F81866_Reg(0xF5);
    bBuf |= 0x20;
    Set_F81866_Reg(0xF5, bBuf);         //start counting
}
//-----
void DisableWDT(void)
{
    unsigned char bBuf;

    Set_F81866_LD(0x07);
    //switch to logic device 7

    bBuf = Get_F81866_Reg(0xFA);
    bBuf &= ~0x01;
    Set_F81866_Reg(0xFA, bBuf);
    //disable WDTO output

    bBuf = Get_F81866_Reg(0xF5);
    bBuf &= ~0x20;
    bBuf |= 0x40;
    Set_F81866_Reg(0xF5, bBuf);
    //disable WDT
}
//-----
//
// THIS CODE AND INFORMATION IS PROVIDED "AS IS" WITHOUT WARRANTY OF ANY
// KIND, EITHER EXPRESSED OR IMPLIED, INCLUDING BUT NOT LIMITED TO THE
// IMPLIED WARRANTIES OF MERCHANTABILITY AND/OR FITNESS FOR A PARTICULAR
// PURPOSE.
//
//-----
#include "F81866.H"
#include <dos.h>
//-----
unsigned int F81866_BASE;
void Unlock_F81866 (void);
void Lock_F81866 (void);

```

```
//-----  
unsigned int Init_F81866(void)  
{  
    unsigned int result;  
    unsigned char ucDid;  
  
    F81866_BASE = 0x4E;  
    result = F81866_BASE;  
  
    ucDid = Get_F81866_Reg(0x20);  
    if (ucDid == 0x07)  
        //Fintek 81866  
        {  
            goto Init_Finish;  
        }  
  
    F81866_BASE = 0x2E;  
    result = F81866_BASE;  
  
    ucDid = Get_F81866_Reg(0x20);  
    if (ucDid == 0x07)  
        //Fintek 81866  
        {  
            goto Init_Finish;  
        }  
  
    F81866_BASE = 0x00;  
    result = F81866_BASE;  
  
Init_Finish:  
    return (result);  
}  
//-----  
void Unlock_F81866 (void)  
{  
    outportb(F81866_INDEX_PORT, F81866_UNLOCK);  
    outportb(F81866_INDEX_PORT, F81866_UNLOCK);  
}  
//-----  
void Lock_F81866 (void)  
{  
    outportb(F81866_INDEX_PORT, F81866_LOCK);  
}  
//-----  
void Set_F81866_LD( unsigned char LD)  
{  
    Unlock_F81866();  
    outportb(F81866_INDEX_PORT, F81866_REG_LD);  
    outportb(F81866_DATA_PORT, LD);  
    Lock_F81866();  
}  
//-----  
void Set_F81866_Reg( unsigned char REG, unsigned char DATA)  
{  
    Unlock_F81866();  
    outportb(F81866_INDEX_PORT, REG);  
    outportb(F81866_DATA_PORT, DATA);  
    Lock_F81866();  
}  
//-----  
unsigned char Get_F81866_Reg(unsigned char REG)  
{  
    unsigned char Result;  
    Unlock_F81866();  
    outportb(F81866_INDEX_PORT, REG);  
    Result = inportb(F81866_DATA_PORT);  
    Lock_F81866();  
    return Result;  
}  
//-----  
//  
// THIS CODE AND INFORMATION IS PROVIDED "AS IS" WITHOUT WARRANTY OF ANY  
// KIND, EITHER EXPRESSED OR IMPLIED, INCLUDING BUT NOT LIMITED TO THE  
// IMPLIED WARRANTIES OF MERCHANTABILITY AND/OR FITNESS FOR A PARTICULAR  
// PURPOSE.  
//
```

```

//-----
#ifndef __F81866_H
#define __F81866_H
//-----
#define F81866_INDEX_PORT (F81866_BASE)
#define F81866_DATA_PORT (F81866_BASE+1)
//-----
#define F81866_REG_LD 0x07
//-----
#define F81866_UNLOCK 0x87
#define F81866_LOCK 0xAA
//-----
unsigned int Init_F81866(void);
void Set_F81866_LD( unsigned char);
void Set_F81866_Reg( unsigned char, unsigned char);
unsigned char Get_F81866_Reg( unsigned char);
//-----
#endif //__F81866_H

```