

# **IB822 Series**

**Intel® Pentium® Silver /  
Celeron® SoC  
3.5" Disk-Size SBC**

## **User's Manual**

Version 1.0  
(Dec. 2018)

## **Copyright**

© 2018 IBASE Technology, Inc. All rights reserved.

No part of this publication may be reproduced, copied, stored in a retrieval system, translated into any language or transmitted in any form or by any means, electronic, mechanical, photocopying, or otherwise, without the prior written consent of IBASE Technology, Inc. (hereinafter referred to as “IBASE”).

## **Disclaimer**

IBASE reserves the right to make changes and improvements to the products described in this document without prior notice. Every effort has been made to ensure the information in the document is correct; however, IBASE does not guarantee this document is error-free.

IBASE assumes no liability for incidental or consequential damages arising from misapplication or inability to use the product or the information contained herein, nor for any infringements of rights of third parties, which may result from its use.

## **Trademarks**

All the trademarks, registrations and brands mentioned herein are used for identification purposes only and may be trademarks and/or registered trademarks of their respective owners.

## Compliance



This product has passed CE tests for environmental specifications and limits. This product is in accordance with the directives of the European Union (EU). In a domestic environment, this product may cause radio interference in which case users may be required to take adequate measures.



This product has been tested and found to comply with the limits for a Class B device, pursuant to Part 15 of the FCC Rules. These limits are designed to provide reasonable protection against harmful interference in a residential installation. This equipment generates, uses and can radiate radio frequency energy and, if not installed and used in accordance with manufacturer's instructions, may cause harmful interference to radio communications.

## WEEE



This product must not be disposed of as normal household waste, in accordance with the EU directive of for waste electrical and electronic equipment (WEEE - 2012/19/EU). Instead, it should be disposed of by returning it to a municipal recycling collection point. Check local regulations for disposal of electronic products.

## Green IBASE



This product is compliant with the current RoHS restrictions and prohibits use of the following substances in concentrations exceeding 0.1% by weight (1000 ppm) except for cadmium, limited to 0.01% by weight (100 ppm).

- Lead (Pb)
- Mercury (Hg)
- Cadmium (Cd)
- Hexavalent chromium (Cr6+)
- Polybrominated biphenyls (PBB)
- Polybrominated diphenyl ether (PBDE)

## Important Safety Information

Carefully read the precautions before using the board.

### Environmental conditions:

- Use this product in environments with ambient temperatures between 0°C and 60°C.
- Do not leave this product in an environment where the storage temperature may be below -20° C or above 80° C. To prevent from damages, the product must be used in a controlled environment.

### Care for your iBASE products:

- Before cleaning the PCB, unplug all cables and remove the battery.
- Clean the PCB with a circuit board cleaner or degreaser, or use cotton swabs and alcohol.
- Vacuum the dust with a computer vacuum cleaner to prevent the fan from being clogged.



### WARNING

### Attention during use:

- Do not use this product near water.
- Do not spill water or any other liquids on this product.
- Do not place heavy objects on the top of this product.

### Anti-static precautions

- Wear an anti-static wrist strap to avoid electrostatic discharge.
- Place the PCB on an anti-static kit or mat.
- Hold the edges of PCB when handling.
- Touch the edges of non-metallic components of the product instead of the surface of the PCB.
- Ground yourself by touching a grounded conductor or a grounded bit of metal frequently to discharge any static.



### CAUTION

Danger of explosion if the internal lithium-ion battery is replaced by an incorrect type. Replace only with the same or equivalent type recommended by the manufacturer. Dispose of used batteries according to the manufacturer's instructions or recycle them at a local recycling facility or battery collection point.

## Warranty Policy

- **IBASE standard products:**

24-month (2-year) warranty from the date of shipment. If the date of shipment cannot be ascertained, the product serial numbers can be used to determine the approximate shipping date.

- **3<sup>rd</sup>-party parts:**

12-month (1-year) warranty from delivery for the 3<sup>rd</sup>-party parts that are not manufactured by IBASE, such as CPU, CPU cooler, memory, storage devices, power adapter, panel and touchscreen.

- \* PRODUCTS, HOWEVER, THAT FAIL DUE TO MISUSE, ACCIDENT, IMPROPER INSTALLATION OR UNAUTHORIZED REPAIR SHALL BE TREATED AS OUT OF WARRANTY AND CUSTOMERS SHALL BE BILLED FOR REPAIR AND SHIPPING CHARGES.

## Technical Support & Services

1. Visit the IBASE website at [www.ibase.com.tw](http://www.ibase.com.tw) to find the latest information about the product.
2. If you need any further assistance from your distributor or sales representative, prepare the following information of your product and elaborate upon the problem.
  - Product model name
  - Product serial number
  - Detailed description of the problem
  - The error messages in text or in screenshots if there is any
  - The arrangement of the peripherals
  - Software in use (such as OS and application software, including the version numbers)
3. If repair service is required, please log in to the RMA system of the website or and contact your distributor or sales representative for assistance.

# Table of Contents

---

Compliance .....	iii
Important Safety Information .....	iv
Warranty Policy .....	v
Technical Support & Services .....	v
<b>Chapter 1      General Information .....</b>	<b>1</b>
1.1    Introduction .....	2
1.2    Features .....	2
1.3    Packing List .....	3
1.4    Optional Accessories .....	3
1.5    Specifications .....	4
1.6    Block Diagram .....	6
1.7    Overview .....	7
1.8    Dimensions .....	8
<b>Chapter 2      Hardware Configuration .....</b>	<b>9</b>
2.1    Installation .....	10
2.2    Setting the Jumpers .....	11
2.2.1    How to Set Jumpers .....	11
2.3    Jumper & Connector Locations .....	12
2.4    Jumpers Quick Reference .....	13
2.4.1    LVDS Panel Brightness Selection (JP1) .....	13
2.4.2    LVDS Panel Power Selection (JP2) .....	14
2.4.3    eDP Panel Power Selection (JP3) .....	14
2.4.4    eDP / LVDS Panel Selection (JP4) .....	15
2.4.5    Clearing CMOS Data (JP5) .....	15
2.4.6    Clearing ME Register (JP6) .....	16
2.4.7    ATX / AT Power Selection (JP8) .....	16
2.5    Connectors Quick Reference .....	17
2.5.1    eDP Connector (CN1) .....	18
2.5.2    Console COM1 RS-232/422/485 Port (CN7) .....	19
2.5.3    LCD Backlight Connector (J2) .....	20
2.5.4    LVDS Connector (J1, J3) .....	20
2.5.5    Audio Connector (J4) .....	21

2.5.6	USB 2.0 Connector (J8).....	21
2.5.7	Amplifier Connector (J6).....	22
2.5.8	SATA HDD Power Connector (J11).....	22
2.5.9	Front Panel Connector (J13).....	23
2.5.10	COM2 / COM3 / COM4 RS-232 Port (J18, J17, J14).....	24
2.5.11	Digital I/O Connector (J19).....	24
2.5.12	DC Power Input Connector (J20).....	25
2.5.13	Battery Connector (BAT1).....	25
<b>Chapter 3 Drivers Installation.....</b>		<b>27</b>
3.1	Introduction.....	28
3.2	Intel® Chipset Software Installation Utility.....	28
3.3	Graphics Driver Installation.....	30
3.4	HD Audio Driver Installation.....	31
3.5	Intel® Trusted Execution Engine Drivers.....	32
3.6	Intel® Serial IO Drivers.....	34
3.7	LAN Driver Installation.....	35
<b>Chapter 4 BIOS Setup.....</b>		<b>37</b>
4.1	Introduction.....	38
4.2	BIOS Setup.....	38
4.3	Main Settings.....	39
4.4	Advanced Settings.....	40
4.4.1	ACPI Computing.....	40
4.4.2	LVDS (eDP/DP) Configuration.....	41
4.4.3	iSmart Controller.....	42
4.4.4	Fintek Super IO Configuration.....	43
4.4.5	Fintek Super IO Hardware Monitor.....	48
4.4.6	M.2 Setup.....	49
4.4.7	CPU Configuration.....	50
4.4.8	AMI Graphic Output Protocol Policy.....	52
4.4.9	Network Stack Configuration.....	53
4.4.10	CSM Configuration.....	54
4.4.11	USB Configuration.....	55
4.5	Chipset Settings.....	56
4.5.1	South Cluster Configuration.....	56
4.6	Security Settings.....	60
4.6.1	Secure Boot.....	61
4.7	Boot Settings.....	63

4.8	Save & Exit Settings .....	64
-----	----------------------------	----

## Appendix ..... 65

A.	I/O Port Address Map .....	66
B.	Interrupt Request Lines (IRQ).....	68
C.	Watchdog Timer Configuration .....	69
D.	Onboard Connector Reference Types .....	73

# Chapter 1

## General Information

The information provided in this chapter includes:

- Features
- Packing List
- Block Diagram
- Specifications
- Board Overview
- Board Dimensions

## 1.1 Introduction

IB822 is a 3.5" disk-size single board computer based on the platform of Intel® Pentium® Silver / Celeron® SoC. It features both DisplayPort and HDMI, and onboard headers for eDP or 18/ 24-bit dual channel LVDS interfaces for video display.

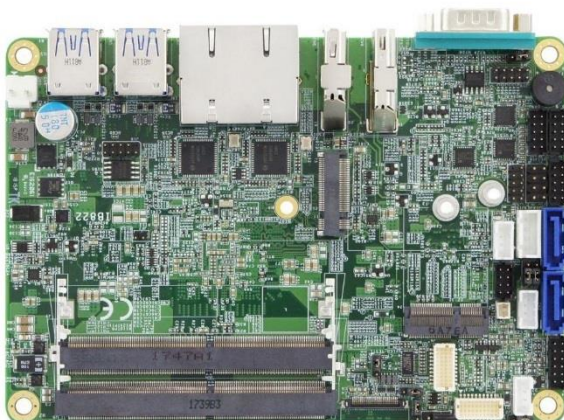

**Photo of IB822**

## 1.2 Features

- 3.5" disk-size SBC with an onboard Intel® Pentium® Silver / Celeron® SoC
- 2 x DDR4-2400 SO-DIMM sockets, expandable up to 8 GB
- 1 x HDMI, 1 x DisplayPort, and eDP / 18/24-bit dual-channel LVDS
- 2 x Intel® 211AT PCI-E Gigabit LAN
- M.2 B2242 & E2230 slots
- Configurable watchdog timer and digital I/O

## 1.3 Packing List

Your product package should include the items listed below. If any of the items below is missing, contact the distributor or dealer from whom you purchased the product.

- IB822 SBC

## 1.4 Optional Accessories

IBASE provides optional accessories as follows. Please contact us or your dealer if you need any.

- Cable Kit (IB76A-1)  
(including:  
SATA cable (SATA-53A) x 1  
Power cable (PW87) x 1  
COM port cable (PK1H) x 1  
USB cable (USB-29) x 1
- Heatsink (HSIB822-A)
- Heat Spreader (HSIB822-1)
- Audio cable (Audio-18)

## 1.5 Specifications

Product Name	IB822F-J5005	IB822-J4005
Form Factor	3.5" disk-size SBC	
<b>System</b>		
Operating System	<ul style="list-style-type: none"> <li>• Window 10 Enterprise (64-bit)</li> <li>• Linux</li> </ul>	
CPU Type	Intel® Pentium® Silver J5005 SoC, 10W TDP	Intel® Celeron® J4005 DC SoC, 10W TDP
CPU Speed	1.5 ~ 2.8 GHz	2.0 GHz / 2.7 GHz
Cache	4 MB	
Chipset	Integrated	
Memory	2 x DDR4-2400 SO-DIMM, expandable up to 8 GB (Non-ECC)	
Graphics	Intel® Pentium® Silver / Celeron® Gen.9-LP with 12/18 EUs	
Network	2 x Intel® I211AT PCIe Gigabit Ethernet	
Super I/O	Fintek F81964D-I	
Audio Codec & Controller	Intel® SoC built-in HD audio controller Realtek ALC269-VC3 codec with class-D speaker amplifier	
Max. Power Requirement	12V: 2.3A	12V: 1.92A
Power Supply	DC-In 12 ~ 24V	
Watchdog Timer	Yes (256 segments, 0, 1, 2...255 sec / min)	
BIOS	AMI BIOS	
iSmart	Yes	
H/W Monitor	Yes	
Dimensions	102 x 147 mm (4.01" x 5.79")	
RoHS	Yes	

<b>Certification</b>	CE, FCC Class B
<b>I/O Ports</b>	
<b>Display</b>	<ul style="list-style-type: none"> <li>• <b>1 x HDMI (2.0a)</b>, 4096 x 2160 at 60 Hz</li> <li>• <b>1 x DisplayPort (1.2a)</b>, 4096 x 2304 at 60 Hz</li> <li>• <b>1 x eDP or 18/24-bit dual channel LVDS</b> eDP: 4096 x 2160 at 60 Hz LVDS: 1920 x 1200 at 60 Hz</li> </ul>
<b>LAN</b>	2 x RJ45 GbE LAN
<b>USB</b>	<ul style="list-style-type: none"> <li>• <b>4 x USB 3.0 (5 GB/s)</b>: edge I/O connectors</li> <li>• <b>2 x USB 2.0</b>: via onboard pin headers</li> </ul>
<b>Serial</b>	<b>4 x COM ports:</b> <ul style="list-style-type: none"> <li>• COM1: RS-232/422/485 (DB9 connector, jumper-less selection)</li> <li>• COM2, COM3, COM4: RS-232 only (via onboard box-headers)</li> </ul>
<b>SATA</b>	2 x SATA III (Connector CN3 shares with M.2 B2242)
<b>Digital IO</b>	4-In & 4-Out
<b>Expansion Slots</b>	<ul style="list-style-type: none"> <li>• 1 x M.2 B2242 slot with PCIe (x1), USB 2.0 and SATA (shared with SATA III connector CN3)</li> <li>• 1 x M.2 E2230 slot with PCIe (x1) and USB 2.0</li> </ul>
<b>Environment</b>	
<b>Temperature</b>	<ul style="list-style-type: none"> <li>• <b>Operating:</b> 0 ~ 60 °C (32 ~ 140 °F)</li> <li>• <b>Storage:</b> -20 ~ 80 °C (-4 ~ 176 °F)</li> </ul>
<b>Relative Humidity</b>	0 ~ 90 %, non-condensing at 60 °C

All specifications are subject to change without prior notice.

# 1.6 Block Diagram

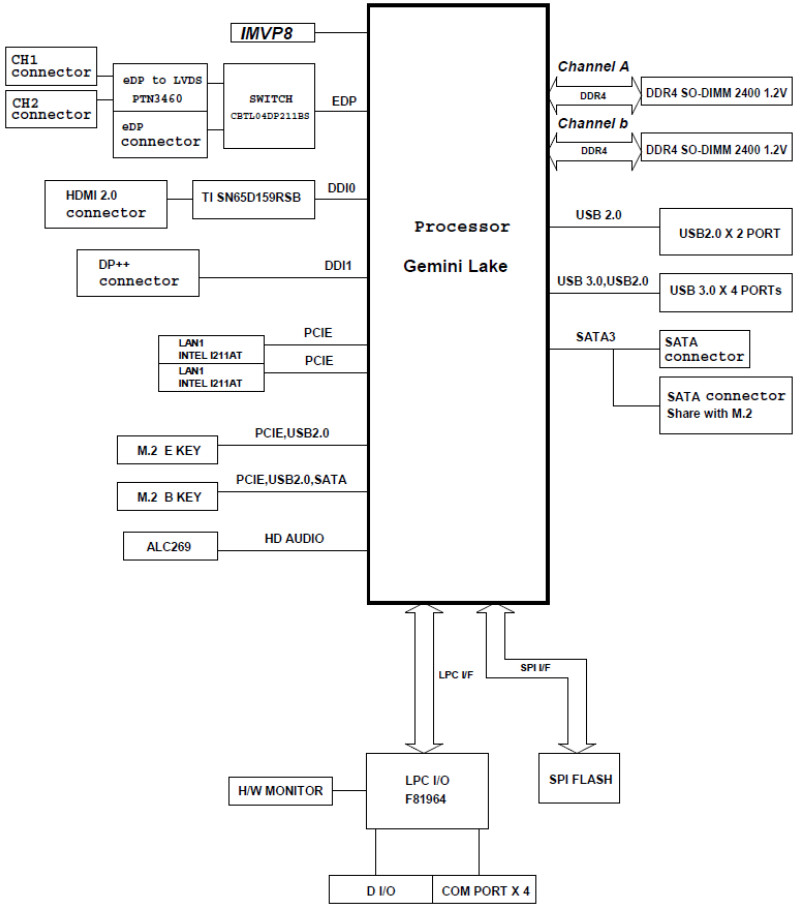

## 1.7 Overview

### Top View

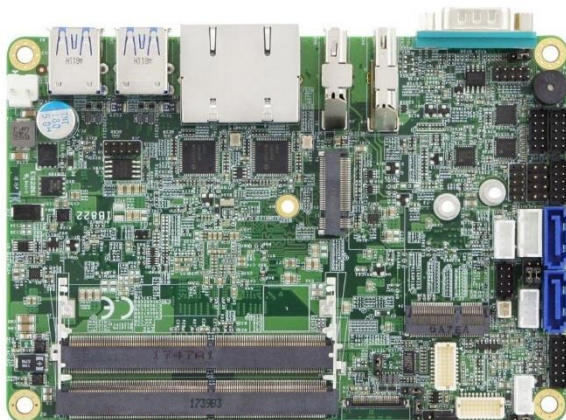

### Bottom View



Photo of IB822

\* The photos above are for reference only. Some minor components may differ.

**I/O View**

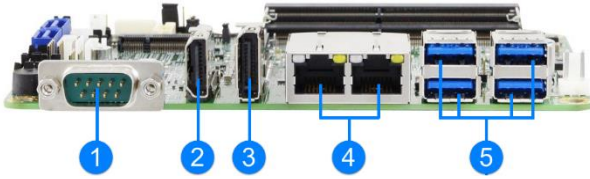

No.	Name	No.	Name
1	COM1 Port	4	LAN Port
2	HDMI Port	5	USB 3.0 Port
3	DisplayPort Port		

**1.8 Dimensions**

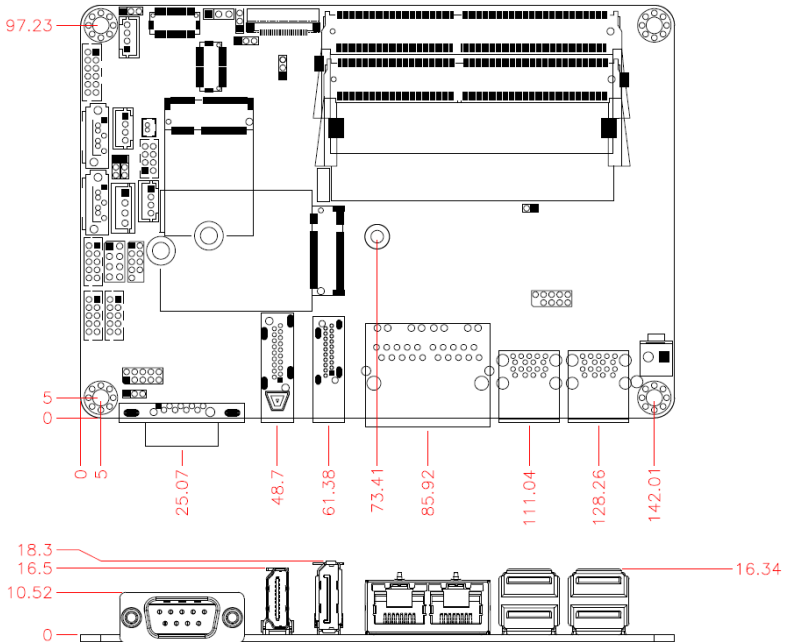

# Chapter 2

## Hardware Configuration

This section provides information on jumper settings and connectors on the board in order to set up a workable system. On top of that, you will also need to install crucial pieces such as the CPU and the memory before using the product. The topics covered are:

- Installations
- Jumper and connector locations
- Jumper settings and information of connectors

## 2.1 Installation

To install the modules, locate the memory slot on the board and perform the following steps:

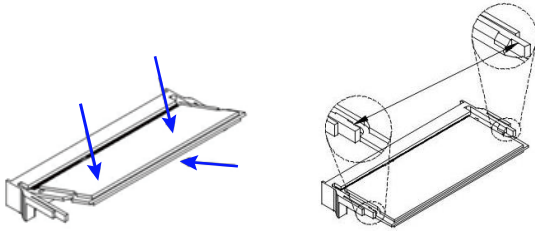

1. Align the key of the memory module with that on the memory slot and insert the module slantwise.
2. Gently push the module in an upright position until the clips of the slot close to hold the module in place when the module touches the bottom of the slot.

To remove the module, press the clips outwards with both hands, and the module will pop-up.

## 2.2 Setting the Jumpers

Set up and configure your board by using jumpers for various settings and features according to your needs and applications. Contact your supplier if you have doubts about the best configuration for your use.

### 2.2.1 How to Set Jumpers

Jumpers are short-length conductors consisting of several metal pins with a non-conductive base mounted on the circuit board. Jumper caps are used to have the functions and features enabled or disabled. If a jumper has 3 pins, you can connect either PIN1 to PIN2 or PIN2 to PIN3 by shorting.

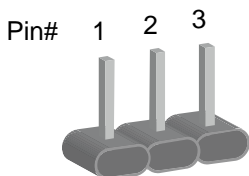

A 3-pin jumper

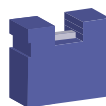

A jumper cap

Refer to the illustration below to set jumpers.

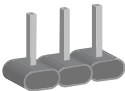
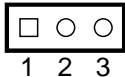
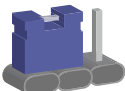
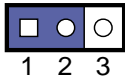
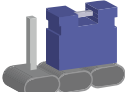
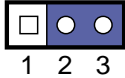
Pin closed	Oblique view	Schematic illustration
Open		
1-2		
2-3		

When two pins of a jumper are encased in a jumper cap, this jumper is **closed**, i.e. turned **On**.

When a jumper cap is removed from two jumper pins, this jumper is **open**, i.e. turned **Off**.

## 2.3 Jumper & Connector Locations

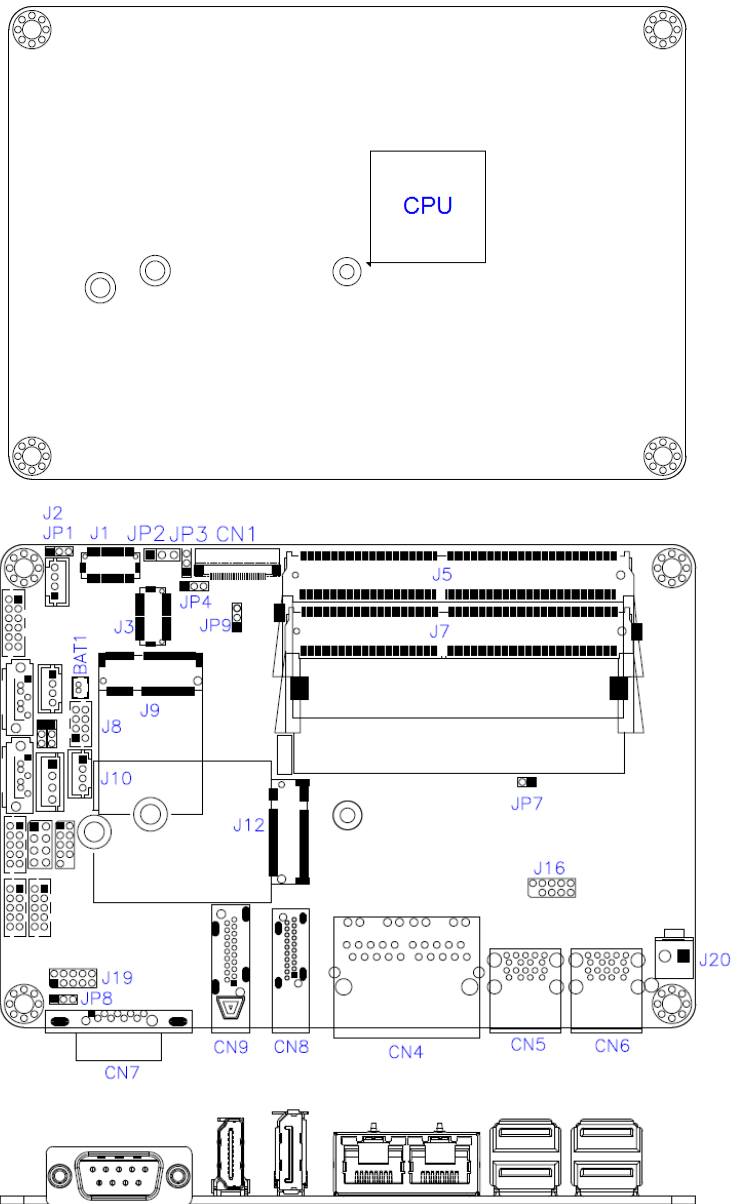

**Board diagram of IB822**

## 2.4 Jumpers Quick Reference

Function	Jumper Name	Page
LCD Panel Brightness Selection	JP1	13
LVDS Panel Power Selection	JP2	14
eDP Panel Power Selection	JP3	14
eDP / LVDS Panel Seelction	JP4	15
Clearing CMOS Data	JP5	15
Clearing ME Register	JP6	16
ATX / AT Power Selection	JP8	16
Factory Use Only	JP7, JP9	--

### 2.4.1 LVDS Panel Brightness Selection (JP1)

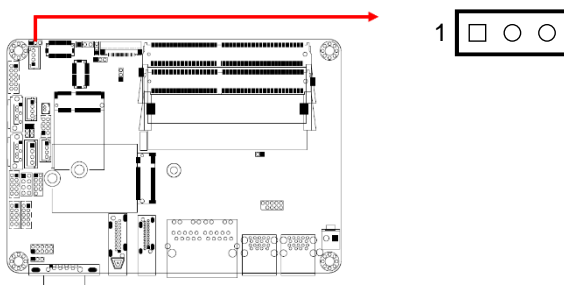

Function	Pin closed	Illustration
3.3V (default)	1-2	1
5V	2-3	1

## 2.4.2 LVDS Panel Power Selection (JP2)

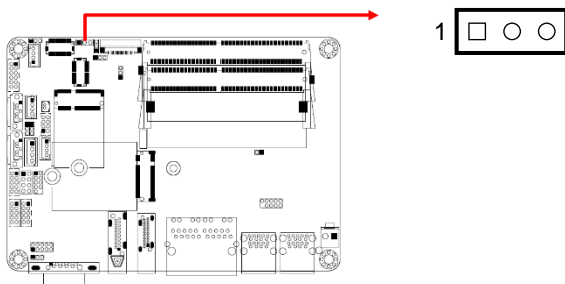

Function	Pin closed	Illustration
3.3V (default)	1-2	1
5V	2-3	1

## 2.4.3 eDP Panel Power Selection (JP3)

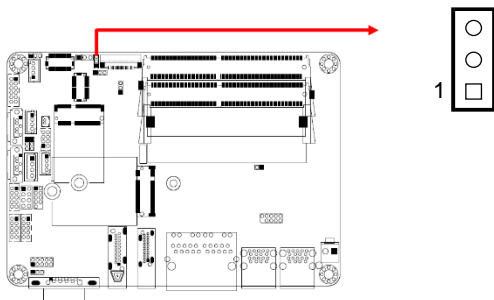

Function	Pin closed	Illustration
3.3V (default)	1-2	1
5V	2-3	1

### 2.4.4 eDP / LVDS Panel Selection (JP4)

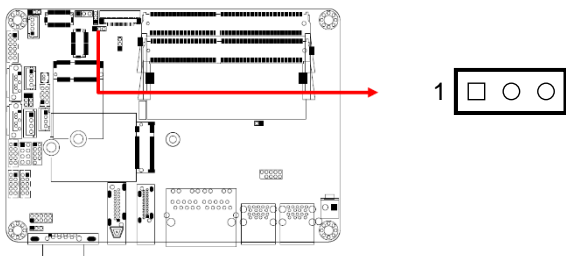

Function	Pin closed	Illustration
eDP	1-2	1
LVDS (default)	2-3	1

### 2.4.5 Clearing CMOS Data (JP5)

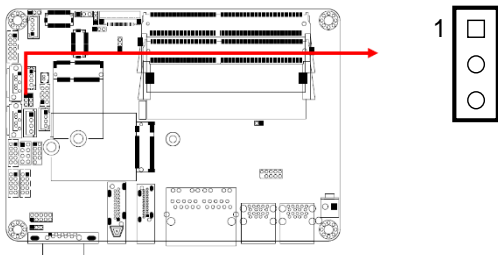

Function	Pin closed	Illustration
Normal (default)	1-2	1
Clear CMOS	2-3	1

## 2.4.6 Clearing ME Register (JP6)

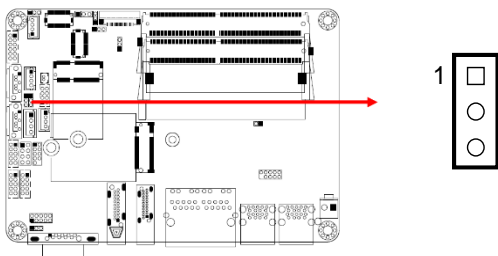

Function	Pin closed	Illustration
Normal (default)	1-2	1
Clear ME	2-3	1

## 2.4.7 ATX / AT Power Selection (JP8)

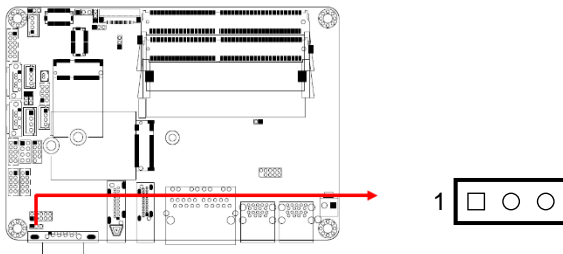

Function	Pin closed	Illustration
ATX (default)	1-2	1
AT	2-3	1

## 2.5 Connectors Quick Reference

Function	Connector Name	Page
eDP Connector	CN1	18
Console COM1 RS-232/422/485 Port	CN7	19
LCD Backlight Connector	J2	20
LVDS Connector	J1, J3	20
Audio Connector	J4	21
USB 2.0 Connector	J8	21
Amplifier Connector	J6	22
SATA HDD Power Connector	J11	22
Front Panel Connector	J13	23
COM2 / COM3 / COM4 RS-232 Port	J18, J17, J14	24
Digital I/O Connector	J19	24
DC Power Input Connector	J20	25
Battery Connector	BAT1	25
SATA III Connector	CN2, CN3 (shared with M.2 B2242)	--
LAN Ports	CN4	--
USB 3.0 Ports	CN5, CN6	--
DisplayPort	CN8	--
HDMI Port	CN9	--
DDR4 SO-DIMM Slot	J5, J7	--
M.2 E2230 Slot	J9	--
M.2 B2242 Slot	J12 (shared with CN3)	--
Factory Use Only	J15, J16	--

## 2.5.1 eDP Connector (CN1)

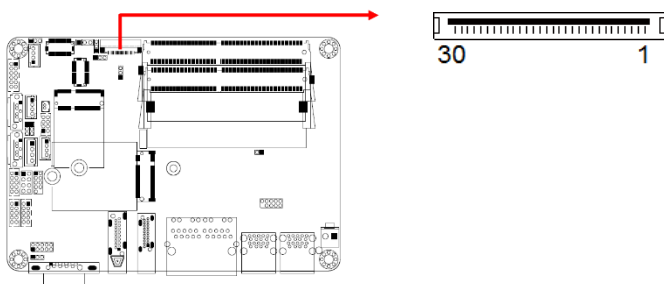

Pin	Assignment	Pin	Assignment
1	NC	16	Ground
2	BL_Power	17	NC
3	BL_Power	18	Panel_VDD
4	BL_Power	19	Panel_VDD
5	BL_Power	20	Ground
6	NC	21	AUX_N
7	NC	22	AUX_P
8	BRIGHTNESS	23	Ground
9	Bklt_en	24	TX0_P
10	Ground	25	TX0_N
11	Ground	26	Ground
12	Ground	27	TX1_P
13	Ground	28	TX1_N
14	HPD	29	Ground
15	Ground	30	NC

## 2.5.2 Console COM1 RS-232/422/485 Port (CN7)

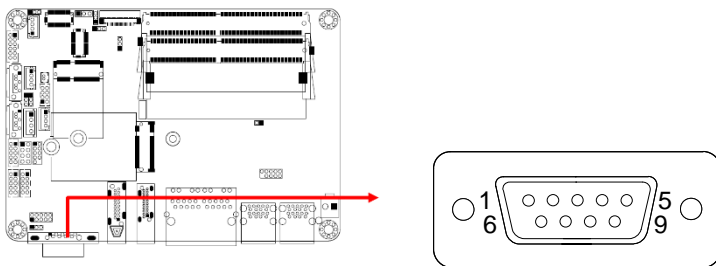

COM1 port is jumper-less and configurable in BIOS.

Pin	Assignment	Pin	Assignment
1	DCD, Data carrier detect	6	DSR, Data set ready
2	RX, Receive	7	RTS, Request to send
3	TX, Transmit	8	CTS, Clear to send
4	DTR, Data terminal ready	9	RI, Ring Indicator
5	Ground		

Pin	Assignment		
	RS-232	RS-422	RS-485
1	DCD	TX-	DATA-
2	RX	TX+	DATA+
3	TX	RX+	NC
4	DTR	RX-	NC
5	Ground	Ground	Ground
6	DSR	NC	NC
7	RTS	NC	NC
8	CTS	NC	NC
9	RI	NC	NC

### 2.5.3 LCD Backlight Connector (J2)

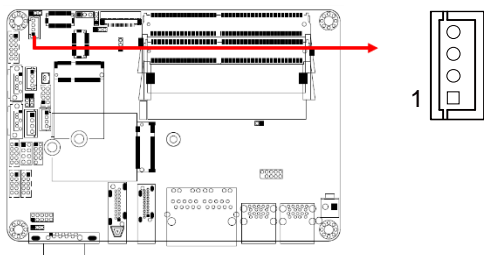

Pin	Assignment	Pin	Assignment
1	+12V	3	Brightness Control
2	Backlight Enable	4	Ground

### 2.5.4 LVDS Connector (J1, J3)

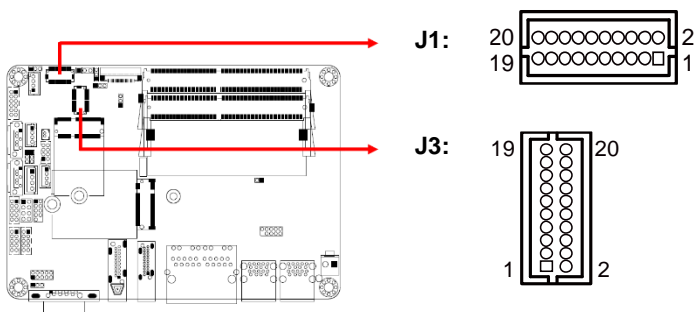

Pin	Assignment	Pin	Assignment
1	TX0P	2	TX0N
3	Ground	4	Ground
5	TX1P	6	TX1N
7	Ground	8	Ground
9	TX2P	10	TX2N
11	Ground	12	Ground
13	CLKP	14	CLKN
15	Ground	16	Ground
17	TX3P	18	TX3N
19	VDD	20	VDD

### 2.5.5 Audio Connector (J4)

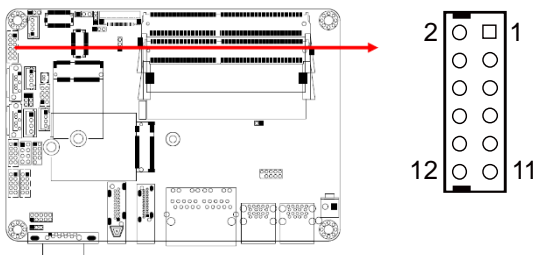

Pin	Assignment	Pin	Assignment
1	Lineout_L	2	Lineout_R
3	JD_FRONT	4	Ground
5	LINEIN_L	6	Linein_R
7	JD_LINEIN	8	Ground
9	MIC_L	10	MIC-R
11	JD_MIC1	12	Ground

### 2.5.6 USB 2.0 Connector (J8)

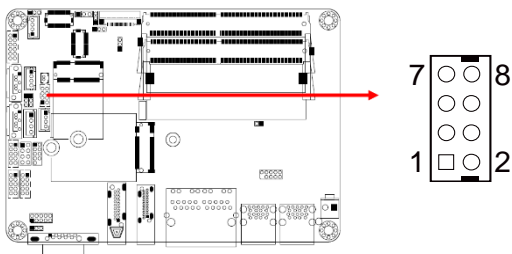

Pin	Assignment	Pin	Assignment
1	VCC	2	Ground
3	D0-	4	D1+
5	D0+	6	D1-
7	Ground	8	VCC

## 2.5.7 Amplifier Connector (J6)

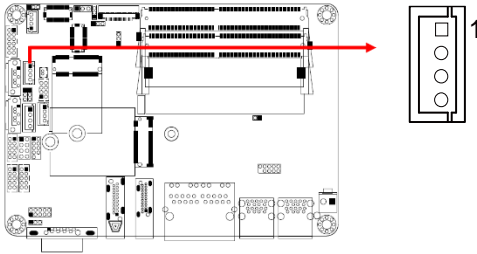

Pin	Assignment	Pin	Assignment
1	OUTL+	3	OUTR-
2	OUTL-	4	OUTR+

## 2.5.8 SATA HDD Power Connector (J11)

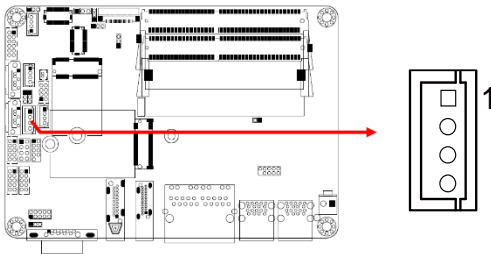

Pin	Assignment	Pin	Assignment
1	+5V	3	Ground
2	Ground	4	+12V

### 2.5.9 Front Panel Connector (J13)

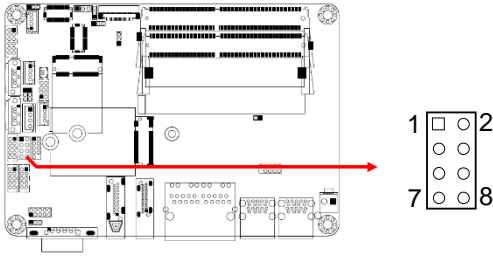

Pin	Assignment	Pin	Assignment
1	Ground	2	PWR_BTN
3	3.3V	4	HDD Active
5	Ground	6	Reset
7	+5V	8	Ground

J13 is utilized for system indicators to provide light indication of the computer activities and switches to change the computer status. It provides interfaces for the following functions.

- ATX Power ON Switch (Pins 1 and 2)**

The 2 pins make an “ATX Power Supply On/Off Switch” for the system that connects to the power switch on the case. When pressed, the power switch will force the system to power on. When pressed again, it will power off the system.
- Hard Disk Drive LED Connector (Pins 3 and 4)**

This connector connects to the hard drive activity LED on control panel. This LED will flash when the HDD is being accessed.
- Reset Switch (Pins 5 and 6)**

The reset switch allows you to reset the system without turning the main power switch off and then on again. Orientation is not required when making a connection to this header.
- Power LED: Pins 7 and 8**

This connector connects to the system power LED on control panel. This LED will light when the system turns on.

### 2.5.10 COM2 / COM3 / COM4 RS-232 Port (J18, J17, J14)

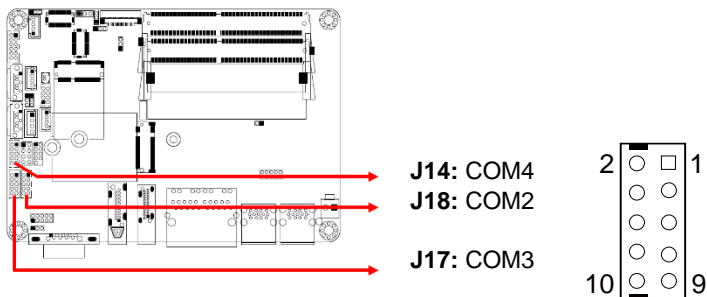

Pin	Assignment	Pin	Assignment
1	DCD, Data carrier detect	2	RXD, Receive data
3	TXD, Transmit data	4	DTR, Data terminal ready
5	Ground	6	DSR, Data set ready
7	RTS, Request to send	8	CTS, Clear to send
9	RI, Ring indicator	10	Not Used

### 2.5.11 Digital I/O Connector (J19)

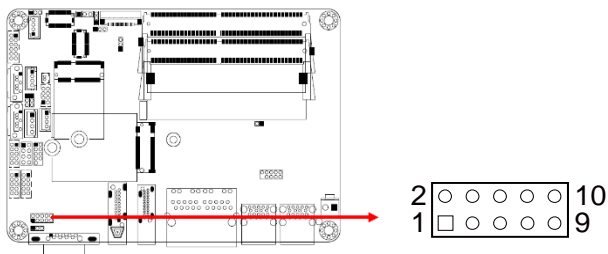

Pin	Assignment	Pin	Assignment
1	Ground	2	VCC
3	OUT3	4	OUT1
5	OUT2	6	OUT0
7	IN3	8	IN1
9	IN2	10	IN0

## 2.5.12 DC Power Input Connector (J20)

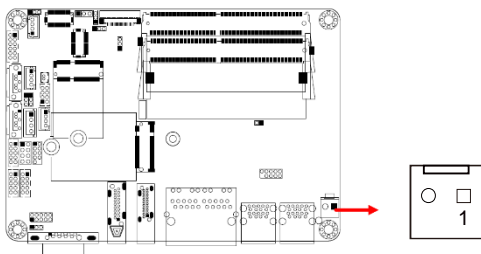

Pin	Assignment	Pin	Assignment
1	+12V ~ +24V	2	Ground

## 2.5.13 Battery Connector (BAT1)

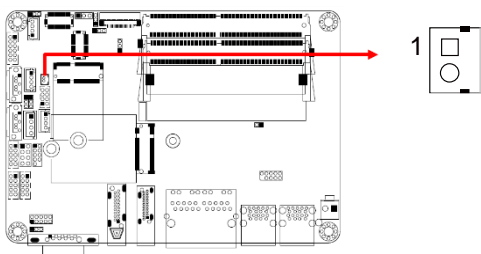

Pin	Assignment	Pin	Assignment
1	Battery+	2	Ground

This page is intentionally left blank.

# Chapter 3

## Drivers Installation

This chapter introduces installation of the following drivers:

- Intel® Chipset Software Installation Utility
- VGA Driver
- HD Audio Driver
- Intel® Trusted Execution Engine Installation
- LAN Driver

## 3.1 Introduction

This section describes the installation procedures for software and drivers. The contents of this section include the following:

---

**Note:** After installing your Windows operating system, you must install the Intel® Chipset Software Installation Utility first before proceeding with the drivers installation.

---

## 3.2 Intel® Chipset Software Installation Utility

The Intel® Chipset drivers should be installed first before the software drivers to install INF files for Plug & Play function for Intel chipset components. Follow the instructions below to complete the installation.

1. Go to the download page of the product. Copy the compressed drivers file to your computer. Double click the file to decompress it. Run “CDGuide” to go to the main drivers page as shown. Click **Intel** on the left pane and **Intel(R) Gemini Lake Chipset Drivers** on the right.



2. Click **Intel(R) Chipset Software Installation Utility**.



3. When the *Welcome* screen to the Intel® Chipset Device Software appears, click **Next** to continue.
4. Accept the software license agreement and proceed with the installation process.
5. On the *Readme File Information* screen, click **Install** for installation.

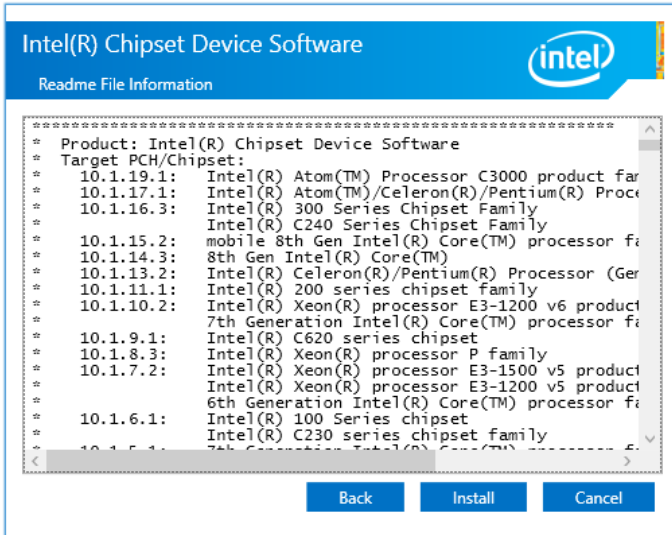

6. The driver has been completely installed. Restart the computer for changes to take effect.

### 3.3 Graphics Driver Installation

1. Click **Intel** on the left pane and then **Intel(R) Gemini Lake Chipset Drivers** on the right pane.



2. Click **Intel(R) Gemini Lake Graphics Driver**.



3. When the the *Welcome* screen appears, click **Next** to continue.



4. Click **Yes** to accept the license agreement and click **Next** until the installation starts.
5. The driver has been completely installed. Restart the computer for changes to take effect.

### 3.4 HD Audio Driver Installation

1. Click **Intel** on the left pane and then **Intel(R) Gemini Lake Chipset Drivers** on the right pane.



2. Click **Realtek High Definition Audio Driver**.



3. On the *Welcome* screen of the InstallShield Wizard, click **Next** for installation.

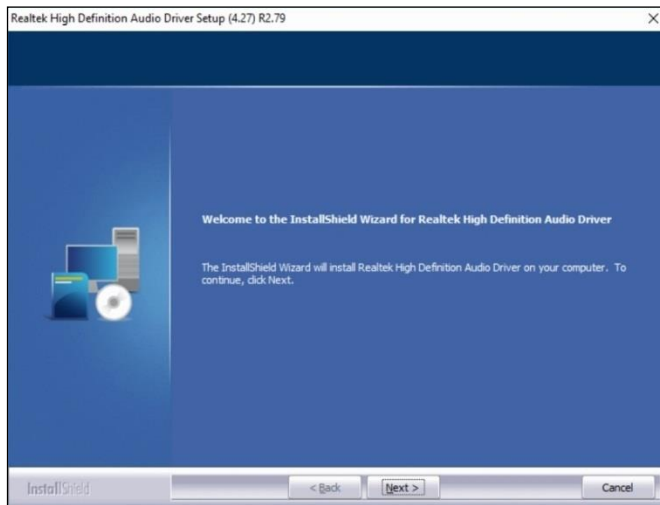

4. Click **Next** until the installation starts.
5. The driver has been completely installed. Restart the computer for changes to take effect.

## 3.5 Intel® Trusted Execution Engine Drivers

1. Click **Intel** on the left pane and then **Intel(R) Gemini Lake Chipset Drivers** on the right pane.



2. Click **Intel(R) TXE Drivers**.



3. When the *Welcome* screen appears, click **Next**.

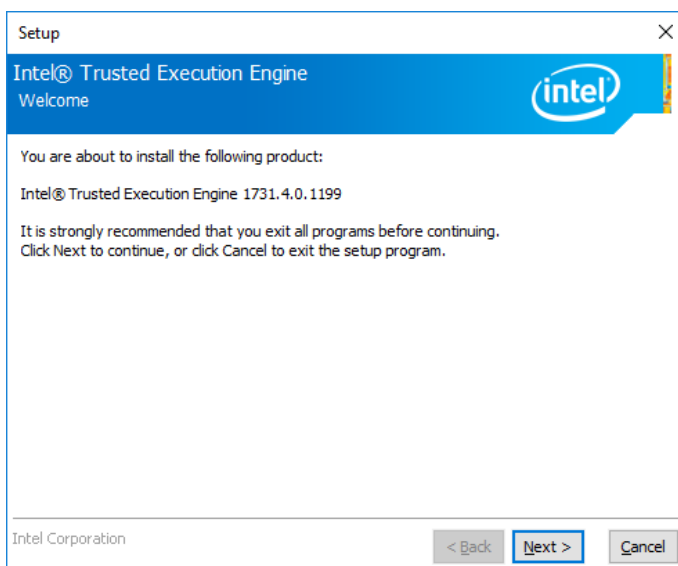

4. Accept the license agreement and click **Next**.
5. Click **Next** for installation.

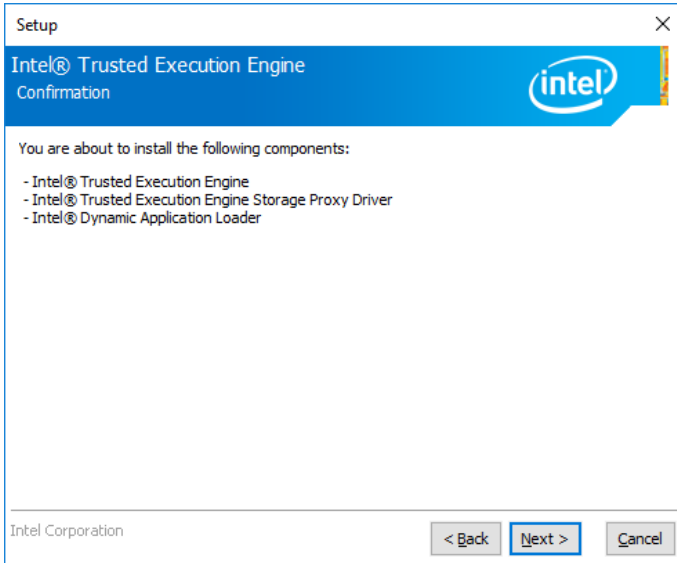

6. As the driver has been successfully installed, restart the computer for changes to take effect.

### 3.6 Intel® Serial IO Drivers

1. Click **Intel** on the left pane and then **Intel(R) Gemini Chipset Drivers** on the right pane.



2. Click **Intel(R) Serial IO Drivers**.



3. As the *Welcome* screen to the InstallShield Wizard appears, click **Next**.

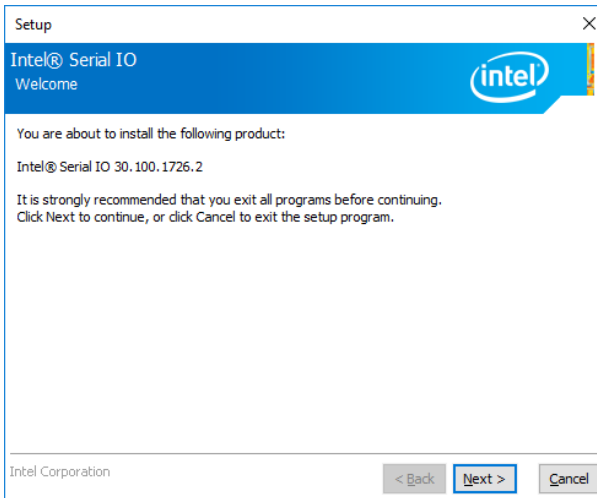

4. Accept the license agreement and click **Next**.
5. After reading the *Readme File*, click **Next** until installation starts.
6. The driver is successfully installed, restart the computer for changes to take effect.

### 3.7 LAN Driver Installation

1. Click **LAN Card** on the left pane and then **Intel LAN Controller Drivers** on the right pane.



2. Click **Intel(R) I21x Gigabit Network Drivers..**



3. When the *Welcome* screen appears, click **Next**.

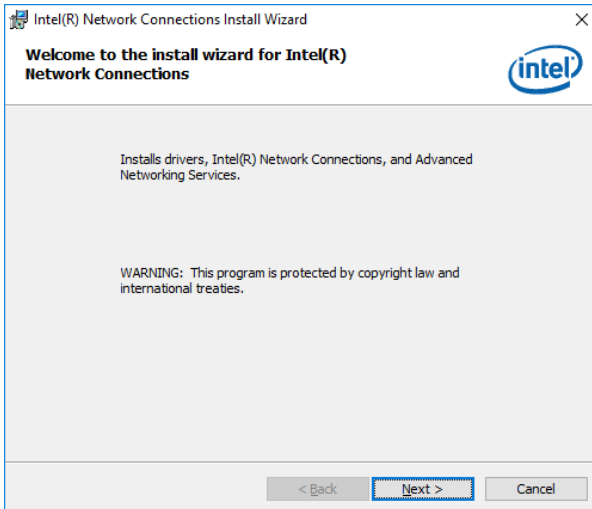

4. Accept the license agreement and click **Next**.

## iBASE

5. On the *Setup Options* screen, click the checkbox to select the desired driver(s) for installation. Then click **Next** to continue.

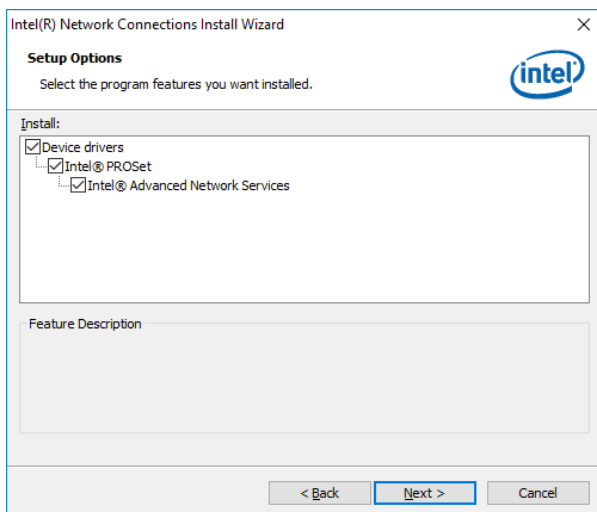

6. The wizard is ready for installation. Click **Install**.
7. As the installation is complete, restart the computer for changes to take effect.

# Chapter 4

## BIOS Setup

This chapter describes the different settings available in the AMI BIOS that comes with the board. The topics covered in this chapter are as follows:

- Main Settings
- Advanced Settings
- Chipset Settings
- Security Settings
- Boot Settings
- Save & Exit

## 4.1 Introduction

The BIOS (Basic Input/Output System) installed in the ROM of your computer system supports Intel® processors. The BIOS provides critical low-level support for standard devices such as disk drives, serial ports and parallel ports. It also provides password protection as well as special support for detailed fine-tuning of the chipset controlling the entire system.

## 4.2 BIOS Setup

The BIOS provides a Setup utility program for specifying the system configurations and settings. The BIOS ROM of the system stores the Setup utility. When you turn on the computer, the BIOS is immediately activated. Press the <Del> key immediately allows you to enter the Setup utility. If you are a little bit late pressing the <Del> key, POST (Power On Self Test) will continue with its test routines, thus preventing you from invoking the Setup.

If you still need to enter Setup, restart the system by pressing the "Reset" button or simultaneously pressing the <Ctrl>, <Alt> and <Delete> keys. You can also restart by turning the system Off and back On again.

The following message will appear on the screen:

```
Press <DEL> to Enter Setup
```

In general, press the arrow keys to highlight items, <Enter> to select, the <PgUp> and <PgDn> keys to change entries, <F1> for help, and <Esc> to quit.

When you enter the BIOS Setup utility, the *Main Menu* screen will appear on the screen. The Main Menu allows you to select from various setup functions and exit choices.

---

**Warning:** It is strongly recommended that you avoid making any changes to the chipset defaults.

These defaults have been carefully chosen by both AMI and your system manufacturer to provide the absolute maximum performance and reliability. Changing the defaults could make the system unstable and crash in some cases.

---

## 4.3 Main Settings

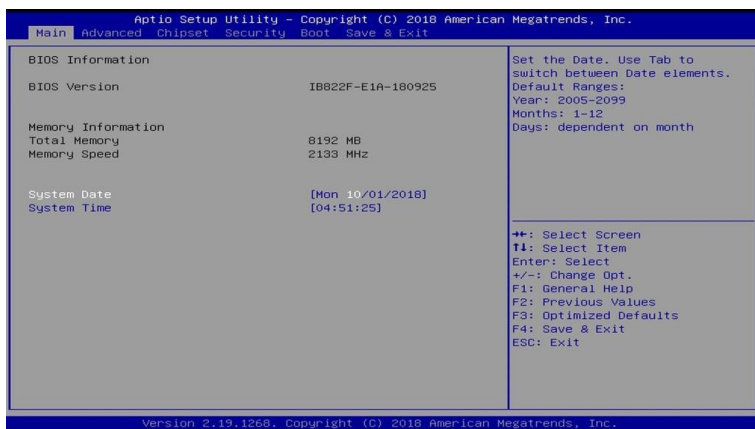

BIOS Setting	Description
System Date	Sets the date. Use the <Tab> key to switch between the date elements.
System Time	Set the time. Use the <Tab> key to switch between the time elements.

## 4.4 Advanced Settings

This section allows you to configure, improve your system and allows you to set up some system features according to your preference.

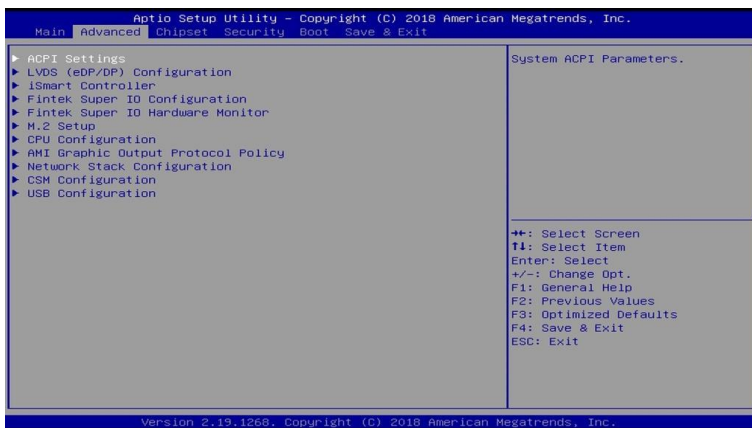

### 4.4.1 ACPI Computing

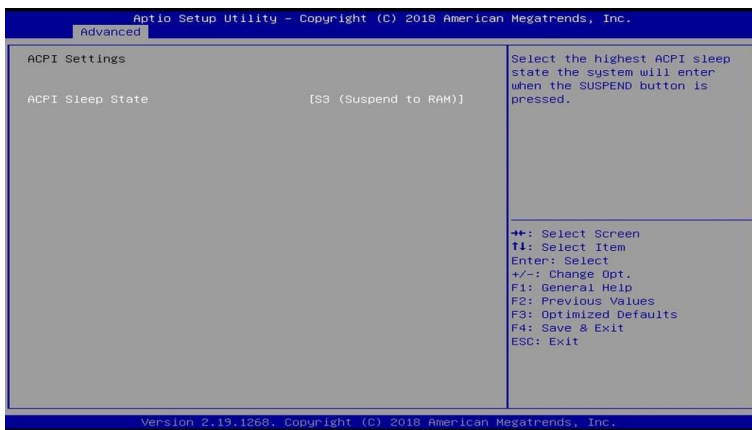

BIOS Setting	Description
ACPI Sleep State	Selects the highest ACPI sleep state (Suspend Disabled or S3) where the system will enter when the Suspend button is pressed.

## 4.4.2 LVDS (eDP/DP) Configuration

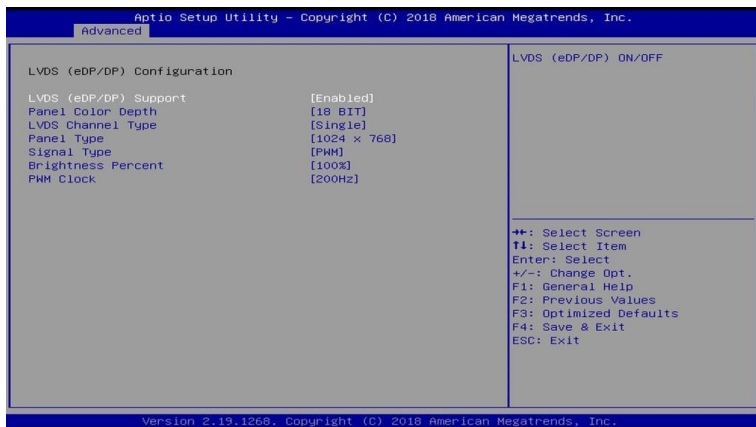

BIOS Setting	Description
LVDS (eDP/DP) Support	Enables / Disables LVDS (eDP/DP)
Panel Color Depth	Selects a panel color depth as 18 or 24 (VESA or JEIDA) bit.
LVDS Channel Type	Sets the LVDS channel type as single or dual channel.
Panel Type	Selects a resolution that fits your panel. Options: 800 x 480 / 800 x 600 / 1024 x 768 / 1280 x 768 / 1280 x 800 / 1280 x 960 / 1280 x 1024 / 1366 x 768 / 1440 x 900 / 1600 x 900 / 1600 x 1200 / 1680 x 1050 / 1920 x 1080 / 1920 x 1200
Signal Type	Allows you to select PWM or DC mode.
Brightness Percent	Options: 100%, 90%, 75%, 60%, 45%, 30%, 20%, 10%
PWM Clock	Options: 200 Hz, 1KHz, 5KHz

### 4.4.3 iSmart Controller

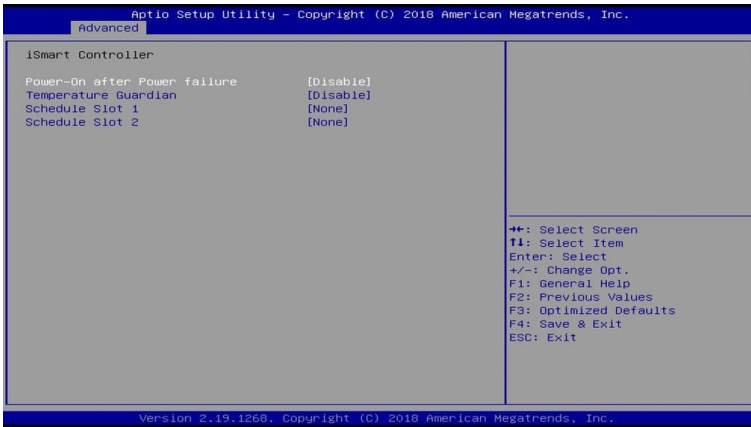

BIOS Setting	Description
Power-On after power failure	Enables / Disables the system to be turned on automatically after a power failure.
Temperature Guardian	Generate the reset signal when system hands up on POST.
Schedule Slots	Sets up the hour / minute / day for the power-on schedule for the system.  Options: None, Power On, Power On/Off

## 4.4.4 Fintek Super IO Configuration

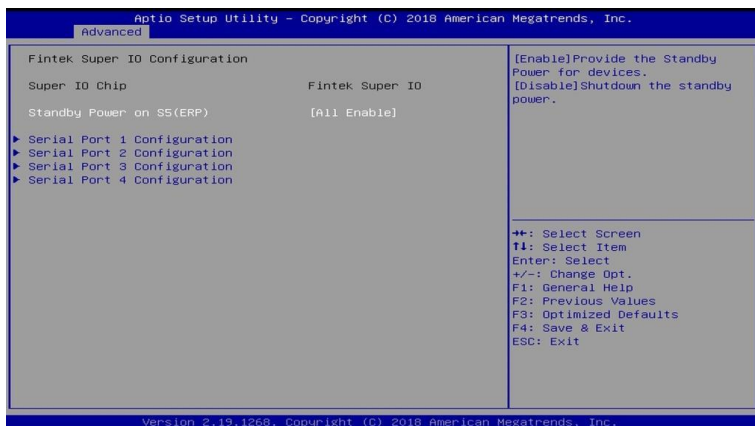

BIOS Setting	Description
Standby Power on S5 (ERP)	Enables / Disables to provide the standby power for devices. Options: All Enable / Enable Ethernet for WOL / All Disable
Serial Ports Configuration	Sets parameters of serial ports. Enables / Disables the serial port and select an optimal setting for the Super IO device.

**4.4.4.1. Serial Port 1 Configuration**

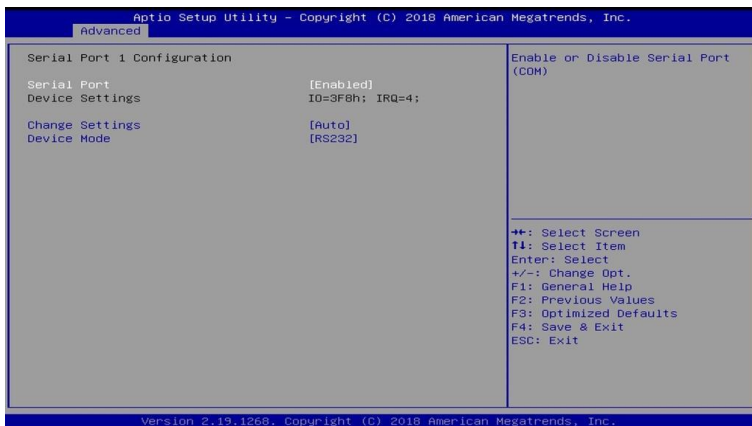

BIOS Setting	Description
Serial Port	Enables / Disables the serial port.
Change Settings	<p>Selects an optimal settings for Super IO device.</p> <p>Options:</p> <ul style="list-style-type: none"> <li>• Auto</li> <li>• IO = 3F8h; IRQ = 4</li> <li>• IO = 3F8h; IRQ = 3, 4, 5, 6, 7, 9, 10, 11, 12</li> <li>• IO = 2F8h; IRQ = 3, 4, 5, 6, 7, 9, 10, 11, 12</li> <li>• IO = 3E8h; IRQ = 3, 4, 5, 6, 7, 9, 10, 11, 12</li> <li>• IO = 2E8h; IRQ = 3, 4, 5, 6, 7, 9, 10, 11, 12</li> </ul>
Device Mode	<p>Changes the serial port mode to:</p> <ul style="list-style-type: none"> <li>• RS232</li> <li>• RS485 TX Low Active</li> <li>• RS485 with Termination TX Low Active</li> <li>• RS422</li> <li>• RS422 with Termination</li> </ul>

### 4.4.4.2. Serial Port 2 Configuration

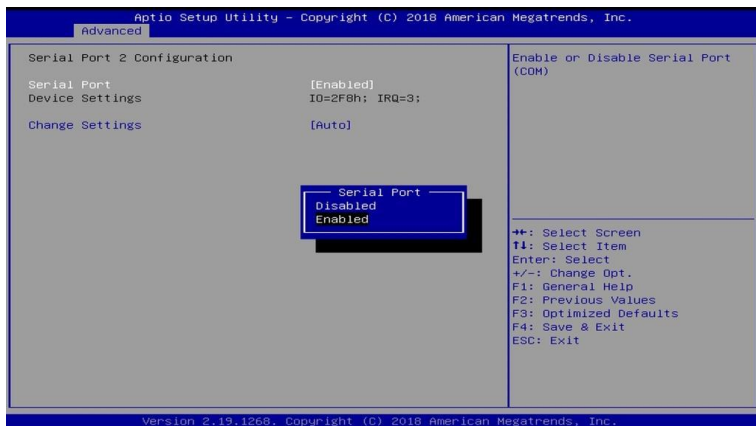

BIOS Setting	Description
Serial Port	Enables / Disables the serial port.
Change Settings	<p>Selects an optimal settings for Super IO device.</p> <p>Options:</p> <ul style="list-style-type: none"> <li>• Auto</li> <li>• IO = 2F8h; IRQ = 3</li> <li>• IO = 3F8h; IRQ = 3, 4, 5, 6, 7, 9, 10, 11, 12</li> <li>• IO = 2F8h; IRQ = 3, 4, 5, 6, 7, 9, 10, 11, 12</li> <li>• IO = 3E8h; IRQ = 3, 4, 5, 6, 7, 9, 10, 11, 12</li> <li>• IO = 2E8h; IRQ = 3, 4, 5, 6, 7, 9, 10, 11, 12</li> </ul>

**4.4.4.3. Serial Port 3 Configuration**

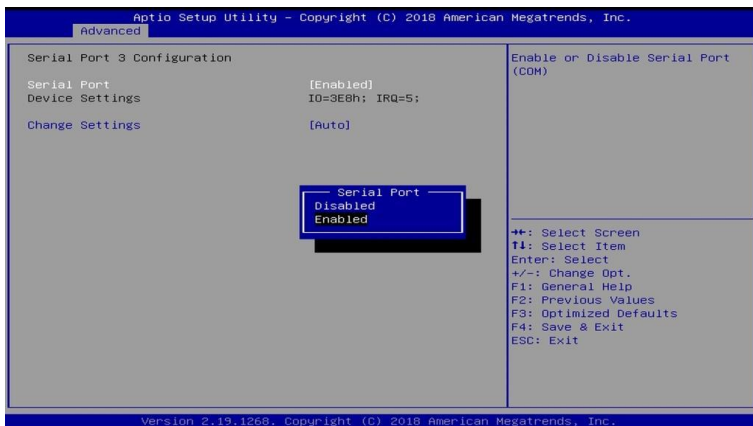

BIOS Setting	Description
Serial Port	Enables / Disables the serial port.
Change Settings	<p>Selects an optimal settings for Super IO device.</p> <p>Options:</p> <ul style="list-style-type: none"> <li>• Auto</li> <li>• IO = 3E8h; IRQ = 7</li> <li>• IO = 3F8h; IRQ = 3, 4, 5, 6, 7, 9, 10, 11, 12</li> <li>• IO = 2E8h; IRQ = 3, 4, 5, 6, 7, 9, 10, 11, 12</li> <li>• IO = 2F0h; IRQ = 3, 4, 5, 6, 7, 9, 10, 11, 12</li> <li>• IO = 2E0h; IRQ = 3, 4, 5, 6, 7, 9, 10, 11, 12</li> </ul>

#### 4.4.4.4. Serial Port 4 Configuration

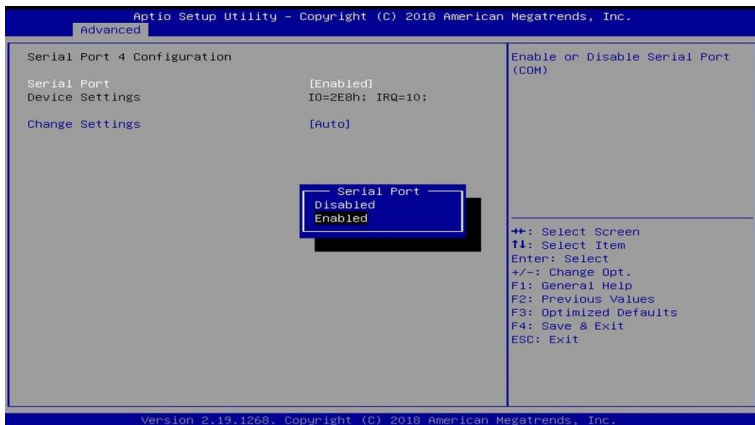

BIOS Setting	Description
Serial Port	Enables / Disables the serial port.
Change Settings	<p>Selects an optimal settings for Super IO device.</p> <p>Options:</p> <ul style="list-style-type: none"> <li>• Auto</li> <li>• IO = 2E8h; IRQ = 7</li> <li>• IO = 3E8h; IRQ = 3, 4, 5, 6, 7, 9, 10, 11, 12</li> <li>• IO = 2E8h; IRQ = 3, 4, 5, 6, 7, 9, 10, 11, 12</li> <li>• IO = 2F0h; IRQ = 3, 4, 5, 6, 7, 9, 10, 11, 12</li> <li>• IO = 2E0h; IRQ = 3, 4, 5, 6, 7, 9, 10, 11, 12</li> </ul>

## 4.4.5 Fintek Super IO Hardware Monitor

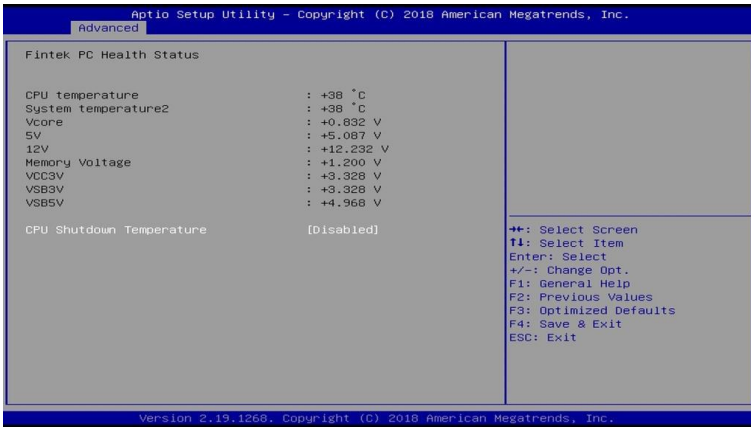

BIOS Setting	Description
Temperatures / Voltages	These fields are the parameters of the hardware monitoring function feature of the motherboard. The values are read-only values as monitored by the system and show the PC health status.
CPU Shutdown Temperature	<p>Sets a threshold of temperature to shut down if CPU goes overheated.</p> <p>Options: Disabled / 70°C / 75°C / 80°C / 85°C / 90°C / 95°C</p>

## 4.4.6 M.2 Setup

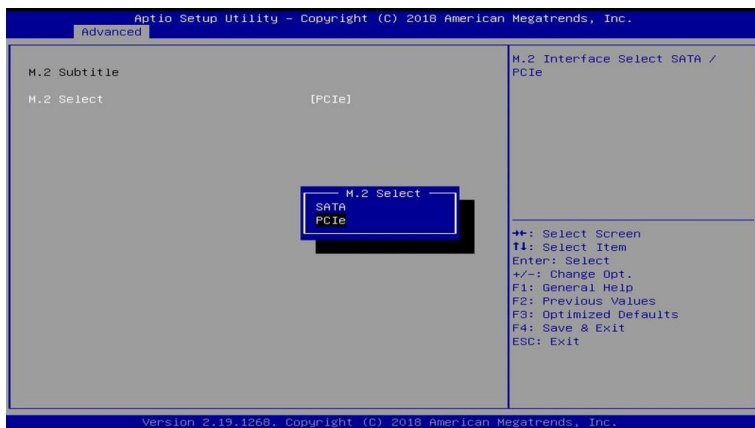

BIOS Setting	Description
M.2 Select	Selects the M.2 interface as SATA or PCIe.

## 4.4.7 CPU Configuration

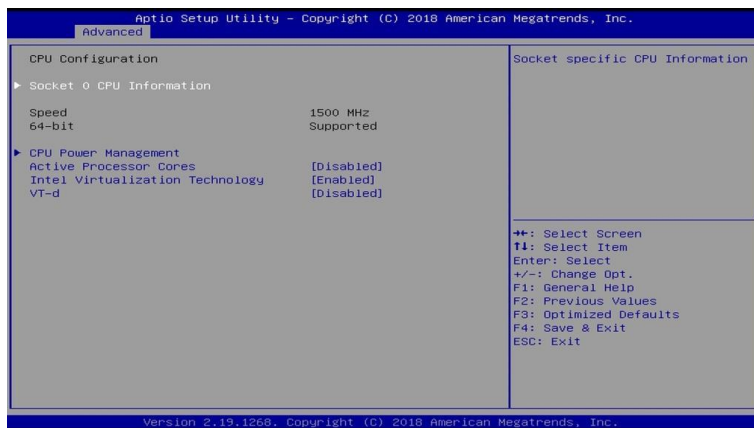

BIOS Setting	Description
Socket 0 CPU Information	Displays the socket specific CPU information.
CPU Power Management	Allows you to enable / disable Turbo Mode.
Active Processor Cores	Enables / Disables the cores in the processor package.
Intel Virtualization Technology	When enabled, a VMM can utilize the additional hardware capabilities provided by Vanderpool Technology.
VT-d	Enables / Disables CPU VT-d.

### 4.4.7.1. Socket 0 CPU Information

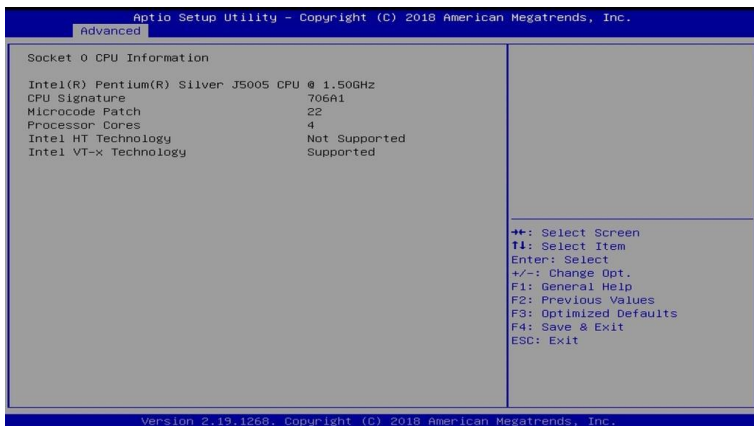

### 4.4.7.2. CPU Power Management Configuration

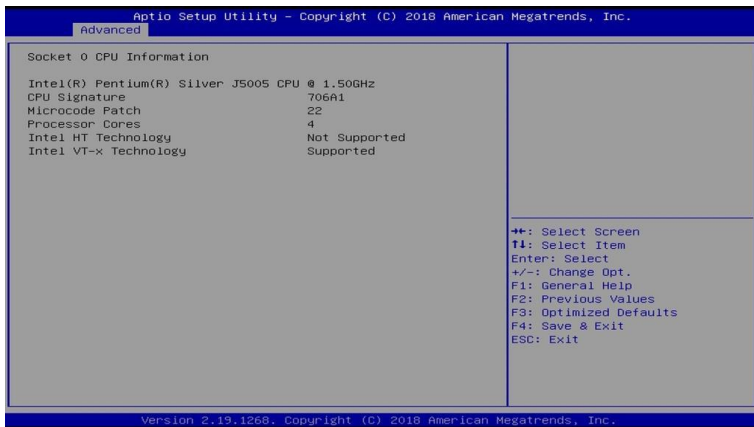

BIOS Setting	Description
EIST	Enables / Disables Intel SpeedStep.
Turbo Mode	Enables / Disables the turbo mode.

## 4.4.8 AMI Graphic Output Protocol Policy

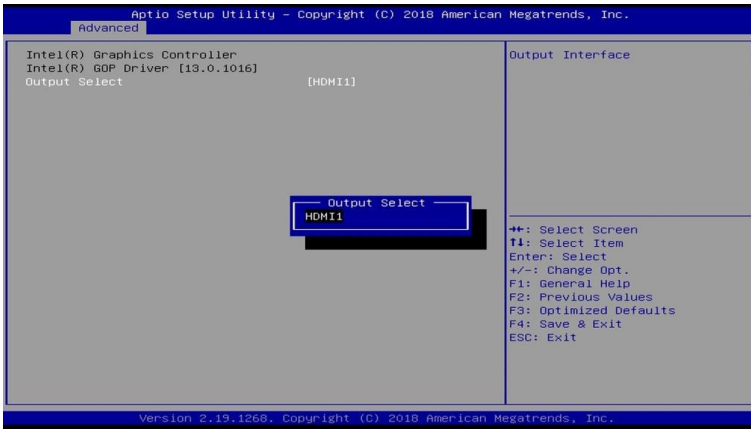

BIOS Setting	Description
Output Select	Outputs through HDMI1 interface.

### 4.4.9 Network Stack Configuration

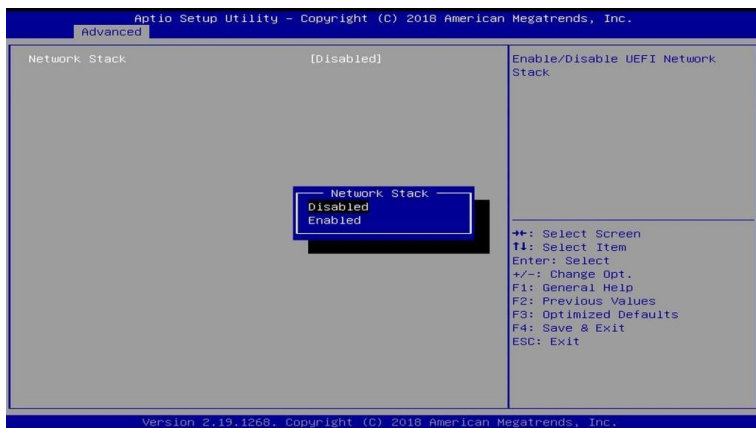

BIOS Setting	Description
Network Stack	Enables / Disables UEFI Network Stack.
IPv4 PXE Support	Enables / Disables IPv4 PXE Boot Support. If disabled, Ipv4 PXE boot option will not be created.
IPv4 HTTP Support	Enables / Disables IPv4 HTTP Boot Support. If disabled, Ipv4 HTTP boot option will not be created.
IPv6 PXE Support	Enables / Disables IPv6 PXE Boot Support. If disabled, Ipv4 PXE boot option will not be created.
IPv6 HTTP Support	Enables / Disables IPv6 HTTP Boot Support. If disabled, Ipv4 HTTP boot option will not be created.
PXE boot wait time	Assigns a period of time to press ESC key to abort the PXE boot.
Media detect count	Assigns a number of times to check the presence of media.

## 4.4.10 CSM Configuration

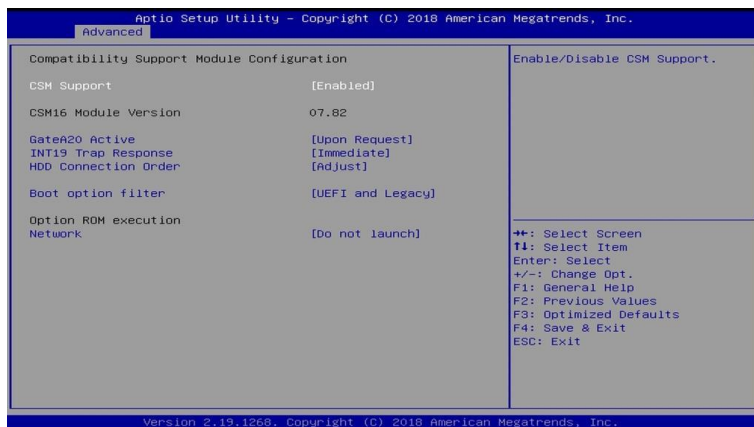

BIOS Setting	Description
CSM Support	Enables / Disables CSM support.
GateA20 Active	<ul style="list-style-type: none"> <li>• <b>Upon Request</b> disables GA20 when using BIOS services.</li> <li>• <b>Always</b> cannot disable GA20, but is useful when any RT code is executed above 1 MB.</li> </ul>
INT19 Trap Response	<p>Sets how BIOS reacts on INT19 trap by Option ROM.</p> <ul style="list-style-type: none"> <li>• <b>Immediate</b> executes the trap right away.</li> <li>• <b>Postponed</b> executes the trap during legacy boot.</li> </ul>
HDD Connection Order	<p>Some operating system require HDD handles to be adjusted., i.e. OS is installed on drive 80h.</p> <p>Options: Adjust, Keep</p>
Boot option filter	<p>Controls the priority of Legacy and UEFI ROMs.</p> <p>Options: UEFI and Legacy, Legacy only, UEFI only</p>
Network	<p>Controls the execution of UEFI and Legacy Network OpROM.</p> <p>Options: Do not launch, UEFI, Legacy</p>

## 4.4.11 USB Configuration

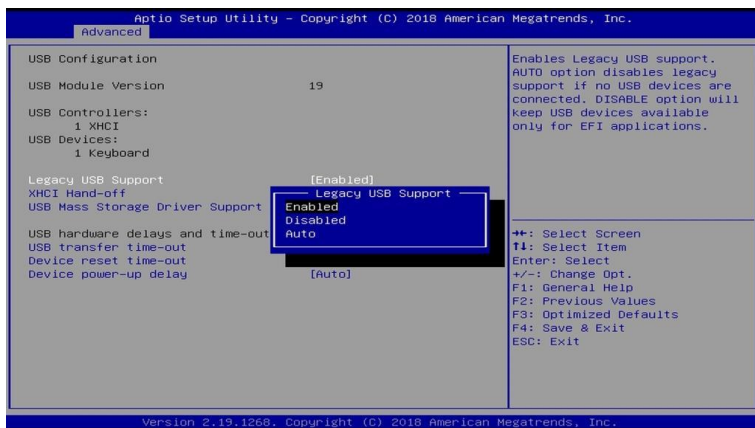

BIOS Setting	Description
Legacy USB Support	<ul style="list-style-type: none"> <li>• <b>Enabled</b> enables Legacy USB support.</li> <li>• <b>Auto</b> disables legacy support if there is no USB device connected.</li> <li>• <b>Disabled</b> keeps USB devices available only for EFI applications.</li> </ul>
XHCI Hand-off	This is a workaround for OSeS without XHCI hand-off support. The XHCI ownership change should be claimed by XHCI driver.
USB Mass Storage Driver Support	Enables / Disables the support for USB mass storage driver.
USB transfer time-out	The time-out value (1 / 5 / 10 / 20 secs) for Control, Bulk, and Interrupt transfers.
Device reset time-out	Gives seconds (10 / 20 / 30 / 40 secs) to delay execution of Start Unit command to USB mass storage device.
Device power-up delay	The maximum time the device will take before it properly reports itself to the Host Controller.  <b>Auto</b> uses default value for a Root port it is 100ms. But for a Hub port, the delay is taken from Hub descriptor.

## 4.5 Chipset Settings



### 4.5.1 South Cluster Configuration

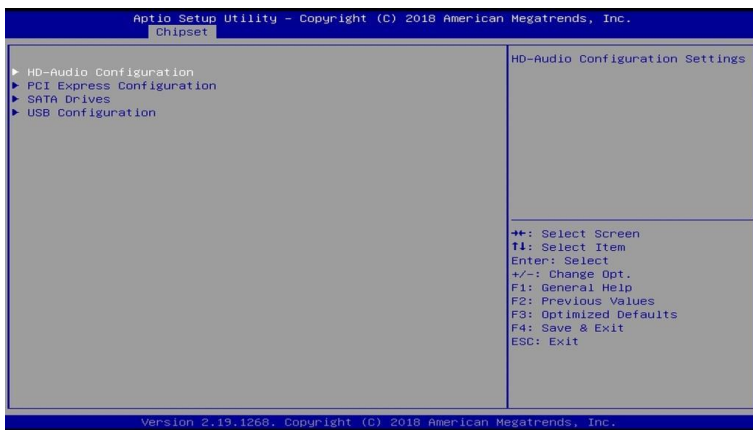

BIOS Setting	Description
HD-Audio Configuration	Configures HD-audio configuration settings.
PCU Express Configuration	Controls the PCI Express root port.
SATA Drives	Determines how SATA controller(s) operate.
USB Configuration	Configures XHCI pre-boot driver, XHCI mode, USB VBUS, USB HSIC1, USB disable override, XDCI and XHCI.

### 4.5.1.1. HD Audio Configuration

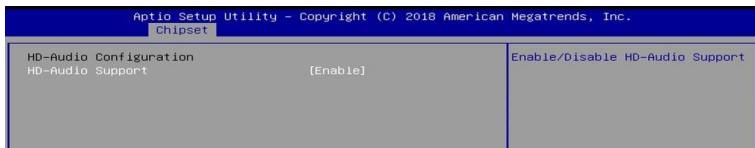

### 4.5.1.2. PCI Express Configuration



BIOS Setting	Description
PCI Express Root Port 1 ~ 6	Accesses the control of the PCI Express Root Port.

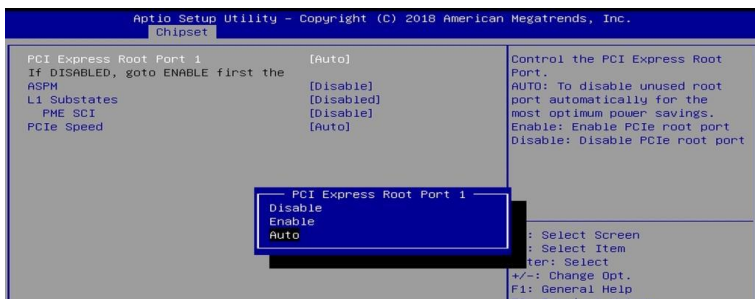

BIOS Setting	Description
PCI Express Root Port 1~6	Enables/ Disables the PCIe root port. <b>Auto:</b> To disable unused root port automatically for the most optimum power savings.
ASPM	Sets the PCIe active state power management. Options: Disable / L0s / L1 / L0SL1 / Auto
L1 Substates	Sets PCIe L1 substates. Options: Disables / L1.1 / L1.2 / L1.1 & L1.2
PME SCI	Enables / Disables PME SCI.
PCIe Speed	Configures the PCIe speed. Options: Auto, Gen1, Gen2

**4.5.1.3. SATA Drivers**

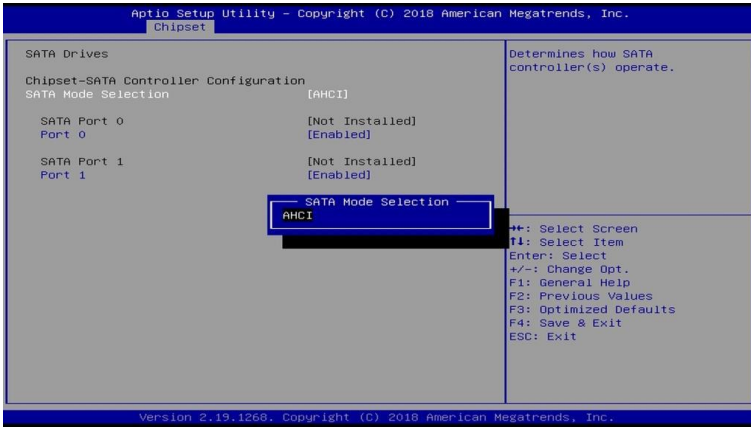

BIOS Setting	Description
SATA Mode Selection	Determines how SATA controller(s) operate.
SATA Port 0 / 1	Enables / Disables SATA port 0 or port 1.

### 4.5.1.4. USB Configuration

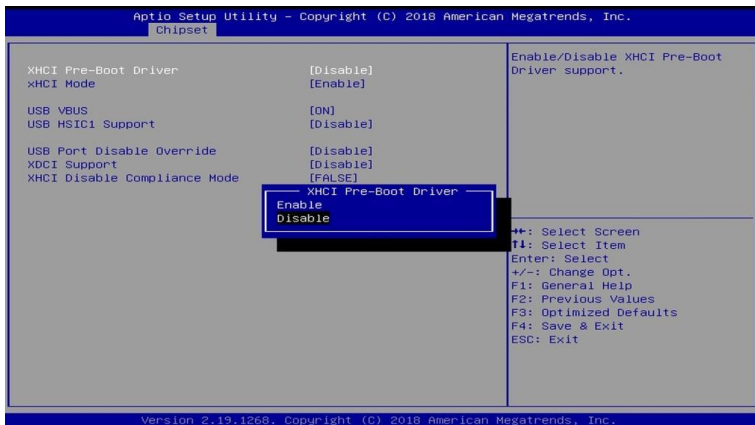

BIOS Setting	Description
XHCI Pre-Boot Driver	Enables / Disables the support for XHCI Pre-Boot Driver.
XHCI Mode	Enables / Disables XHCI mode. If disabled, XHCI controller would be disabled, and none of the USB devices are detectable or usable when system is booted up in OS.  Do NOT disable it unless for debug purpose.
USB VBUS	VBUS should be ON in HOST mode. It should be OFF in OTG device mode.
USB HSIC1 Support	Enables / Disables USB HSIC1.
USB Port Disable Override	Selectively enables / disables the corresponding USB port from reporting a device connection to the controller.
XDCI Support	Enables / Disables XDCI.
XHCI Disable Compliance Mode	<b>FALSE</b> makes the XHCI Link Compliance Mode not disabled.  <b>TRUE</b> disables the XHCI Link Compliance Mode.

## 4.6 Security Settings



BIOS Setting	Description
Setup Administrator Password	Sets an administrator password for the setup utility.
User Password	Sets a user password.
Secure Boot	Activates when: secure Boot is enabled, Platform Key (PK) is enrolled, System mode is user / depolyed, and CSM is disabled.

### 4.6.1 Secure Boot

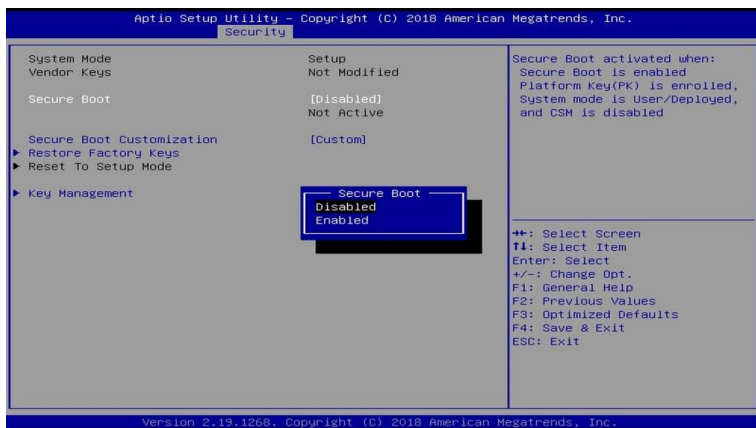

BIOS Setting	Description
Secure Boot	Activates when: secure Boot is enabled, Platform Key (PK) is enrolled, System mode is user / depolyed, and CSM is disabled.
Secure Boot Customization	Customizable Secure Boot mode: In Custom mode, Secure Boot polocy variables can be configured by a physically present user without full authentication.
Restore Factory Keys	Force System to User Mode. Configure NVRAM to contain OEM-defined factory default Secure Boot keys.

### 4.6.1.1. Factory Key Provision

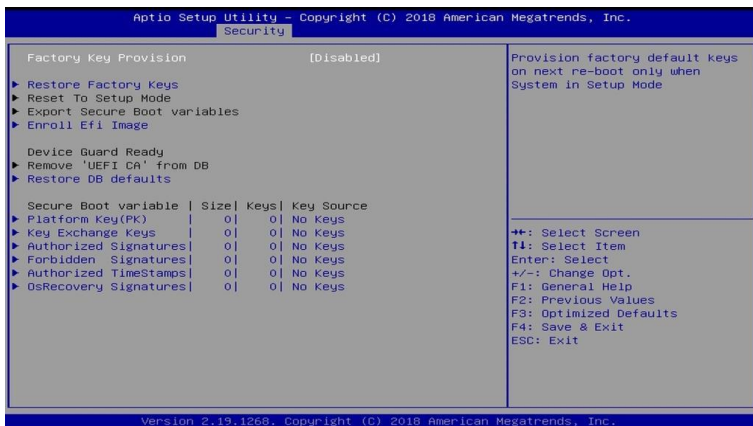

BIOS Setting	Description
Restore Factory Keys	Provision factory default keys on next re-boot only when the system is in Setup mode.
Restore Factory Keys	Force system to user mode. Configure NVRAM to contain OEM-defined factory default secure boot keys.
Enroll Efi Image	Allows the image to run in Secure Boot mode. Enroll SHA256 Hash certificate of a PE image into Authorized signature database (db).
Restore DB defaults	Restore DB variable to factory defaults.
Platform Key (PK) / Key Exchange Keys / Authorized Signatures / Forbidden Signatures / Authorized TimeStamps / OsRecovery Signatures	Enrolls factory defaults or load certificates from a file: 1.) Public Key Certificate in: EFI_SIGNATURE_LIST / EFI_CERT_XS09 (DER encoded) / EFI-CERT_RSA2048 (bin) / EFI_CERT_SHA256,384,512 2.) Authenticated UEFI Variable 3.) EFI PE/COFF Image (SHA256) Key source: factory, external, mixed

## 4.7 Boot Settings

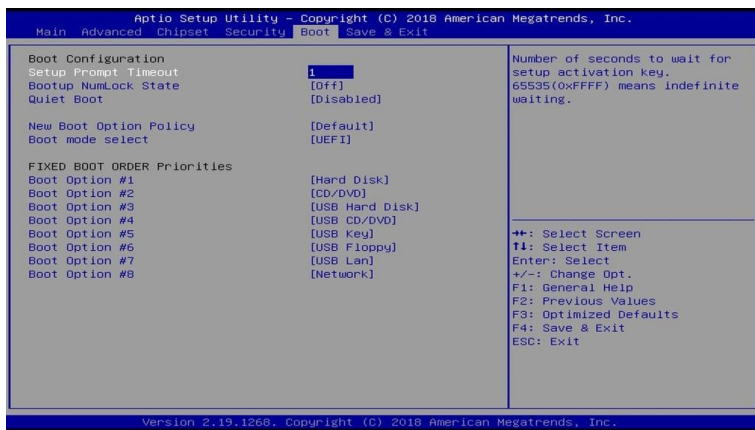

BIOS Setting	Description
Setup Prompt Timeout	Number of seconds to wait for setup activation key. 65535 (0xFFFF) means indefinite waiting.
Bootup NumLock State	Selects the keyboard NumLock state.
New Boot Option Policy	Controls the placement of newly detected UEFI boot options. Options: Default, Place First, Place Last
Boot mode select	Selects a Boot mode, Legacy / UEFI / Dual.
Boot Option Priorities	Sets the system boot order priorities for hard disk, CD/DVD, USB, Network.

## 4.8 Save & Exit Settings

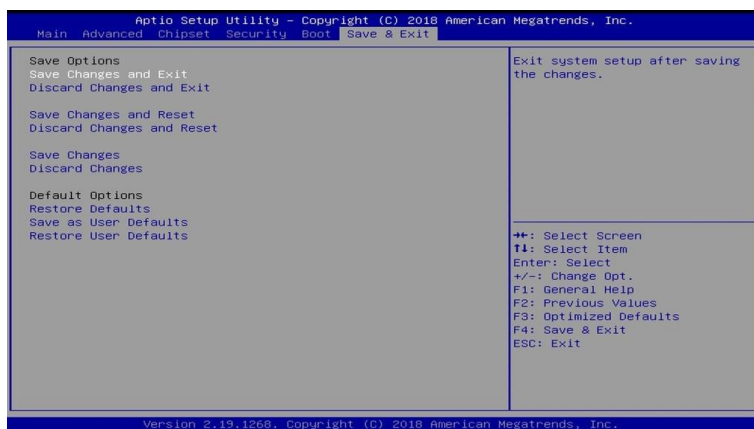

BIOS Setting	Description
Save Changes and Exit	Exits system setup after saving the changes.
Discard Changes and Exit	Exits system setup without saving any changes.
Save Changes and Reset	Resets the system after saving the changes.
Discard Changes and Reset	Resets system setup without saving any changes.
Save Changes	Saves changes done so far to any of the setup options.
Discard Changes	Discards changes done so far to any of the setup options.
Restore Defaults	Restores / Loads defaults values for all the setup options.
Save as User Defaults	Saves the changes done so far as User Defaults.
Restore User Defaults	Restores the user defaults to all the setup options.

# Appendix

This section provides the mapping addresses of peripheral devices and the sample code of watchdog timer configuration.

## A. I/O Port Address Map

Each peripheral device in the system is assigned a set of I/O port addresses which also becomes the identity of the device. The following table lists the I/O port addresses used.

Address	Device Description
0x00000A00-0x00000A0F	Motherboard resources
0x00000A10-0x00000A1F	Motherboard resources
0x00000A20-0x00000A2F	Motherboard resources
0x0000002E-0x0000002F	Motherboard resources
0x0000004E-0x0000004F	Motherboard resources
0x00000061-0x00000061	Motherboard resources
0x00000063-0x00000063	Motherboard resources
0x00000065-0x00000065	Motherboard resources
0x00000067-0x00000067	Motherboard resources
0x00000070-0x00000070	Motherboard resources
0x00000070-0x00000070	System CMOS/real time clock
0x00000080-0x0000008F	Motherboard resources
0x00000092-0x00000092	Motherboard resources
0x000000B2-0x000000B3	Motherboard resources
0x00000680-0x0000069F	Motherboard resources
0x00000400-0x0000047F	Motherboard resources
0x00000500-0x000005FE	Motherboard resources
0x00000600-0x0000061F	Motherboard resources
0x0000164E-0x0000164F	Motherboard resources
0x0000F040-0x0000F05F	Intel(R) Celeron(R)/Pentium(R) Processor SMBUS - 5AD4
0x0000D000-0x0000DFFF	Intel(R) Celeron(R)/Pentium(R) Processor PCI Express Root Port - 5AD9
0x000003F8-0x000003FF	Communications Port (COM1)
0x000002F8-0x000002FF	Communications Port (COM2)
0x000003E8-0x000003EF	Communications Port (COM3)
0x000002E8-0x000002EF	Communications Port (COM4)
0x0000E000-0x0000EFFF	Intel(R) Celeron(R)/Pentium(R) Processor PCI Express Root Port - 5AD8

Address	Device Description
0x00000000-0x0000006F	PCI Express Root Complex
0x00000078-0x00000CF7	PCI Express Root Complex
0x00000D00-0x0000FFFF	PCI Express Root Complex
0x00000020-0x00000021	Programmable interrupt controller
0x00000024-0x00000025	Programmable interrupt controller
0x00000028-0x00000029	Programmable interrupt controller
0x0000002C-0x0000002D	Programmable interrupt controller
0x00000030-0x00000031	Programmable interrupt controller
0x00000034-0x00000035	Programmable interrupt controller
0x00000038-0x00000039	Programmable interrupt controller
0x0000003C-0x0000003D	Programmable interrupt controller
0x000000A0-0x000000A1	Programmable interrupt controller
0x000000A4-0x000000A5	Programmable interrupt controller
0x000000A8-0x000000A9	Programmable interrupt controller
0x000000AC-0x000000AD	Programmable interrupt controller
0x000000B0-0x000000B1	Programmable interrupt controller
0x000000B4-0x000000B5	Programmable interrupt controller
0x000000B8-0x000000B9	Programmable interrupt controller
0x000000BC-0x000000BD	Programmable interrupt controller
0x000004D0-0x000004D1	Programmable interrupt controller
0x0000F000-0x0000F03F	Intel(R) HD Graphics
0x0000F090-0x0000F097	Standard SATA AHCI Controller
0x0000F080-0x0000F083	Standard SATA AHCI Controller
0x0000F060-0x0000F07F	Standard SATA AHCI Controller
0x00000040-0x00000043	System timer
0x00000050-0x00000053	System timer

## B. Interrupt Request Lines (IRQ)

Peripheral devices use interrupt request lines to notify CPU for the service required. The following table shows the IRQ used by the devices on board.

Level	Function
IRQ 0	System timer
IRQ 3	Communications Port (COM2)
IRQ 4	Communications Port (COM1)
IRQ 4	PCI Data Acquisition and Signal Processing Controller
IRQ 5	Communications Port (COM3)
IRQ 5	PCI Data Acquisition and Signal Processing Controller
IRQ 6	PCI Data Acquisition and Signal Processing Controller
IRQ 7	PCI Data Acquisition and Signal Processing Controller
IRQ 8	High precision event timer
IRQ 10	Communications Port (COM4)
IRQ 14	Intel(R) Serial IO GPIO Host Controller - INT3452
IRQ 25	High Definition Audio Controller
IRQ 35	PCI Data Acquisition and Signal Processing Controller
IRQ 36	PCI Data Acquisition and Signal Processing Controller
IRQ 37	PCI Data Acquisition and Signal Processing Controller
IRQ 39	SDA Standard Compliant SD Host Controller
IRQ 54 ~ IRQ 204	Microsoft ACPI-Compliant System
IRQ 256 ~ IRQ 511	Microsoft ACPI-Compliant System
IRQ 4294967279	Intel(R) USB 3.0 eXtensible Host Controller - 1.0 (Microsoft)
IRQ 4294967280 ~ IRQ 4294967285	Intel(R) I211 Gigabit Network Connection #2
IRQ 4294967286 ~ IRQ 4294967291	Intel(R) I211 Gigabit Network Connection
IRQ 4294967292	Intel(R) Trusted Execution Engine Interface
IRQ 4294967293	Intel(R) HD Graphics
IRQ 4294967294	Standard SATA AHCI Controller

## C. Watchdog Timer Configuration

The Watchdog Timer (WDT) is used to generate a variety of output signals after a user programmable count. The WDT is suitable for use in the prevention of system lock-up, such as when software becomes trapped in a deadlock. Under these sorts of circumstances, the timer will count to zero and the selected outputs will be driven.

Under normal circumstance, you will need to restart the WDT at regular intervals before the timer counts to zero.

### Sample Code:

```
//-----
//
// THIS CODE AND INFORMATION IS PROVIDED "AS IS" WITHOUT WARRANTY OF ANY
// KIND, EITHER EXPRESSED OR IMPLIED, INCLUDING BUT NOT LIMITED TO THE
// IMPLIED WARRANTIES OF MERCHANTABILITY AND/OR FITNESS FOR A PARTICULAR
// PURPOSE.
//
//-----
#include <dos.h>
#include <conio.h>
#include <stdio.h>
#include <stdlib.h>
#include "F81964.H"
//-----
int main (int argc, char *argv[]);
void EnableWDT(int);
void DisableWDT(void);
//-----
int main (int argc, char *argv[])
{
    unsigned char bBuf;
    unsigned char bTime;
    char **endptr;

    char SIO;

    printf("Fintek 81964 watch dog program\n");
    SIO = Init_F81964();
    if (SIO == 0)
    {
        printf("Can not detect Fintek 81964, program abort.\n");
        return(1);
    }
    //if (SIO == 0)

    if (argc != 2)
    {
        printf("Parameter incorrect!!\n");
        return (1);
    }
}
```

```
bTime = strtol(argv[1], endptr, 10);
printf("System will reset after %d seconds\n", bTime);
```

```
if (bTime)
{
    EnableWDT(bTime);
}
else
{
    DisableWDT();
}
return 0;
```

```

}
//-----
void EnableWDT(int interval)
{
    unsigned char bBuf;

    bBuf = Get_F81964_Reg(0x2B);
    bBuf &= (~0x20);
    Set_F81964_Reg(0x2B, bBuf);           //Enable WDTO

    Set_F81964_LD(0x07);                 //switch to logic device 7
    Set_F81964_Reg(0x30, 0x01);         //enable timer

    bBuf = Get_F81964_Reg(0xF5);
    bBuf &= (~0x0F);
    bBuf |= 0x52;
    Set_F81964_Reg(0xF5, bBuf);         //count mode is second

    Set_F81964_Reg(0xF6, interval);     //set timer

    bBuf = Get_F81964_Reg(0xFA);
    bBuf |= 0x01;
    Set_F81964_Reg(0xFA, bBuf);         //enable WDTO output

    bBuf = Get_F81964_Reg(0xF5);
    bBuf |= 0x20;
    Set_F81964_Reg(0xF5, bBuf);         //start counting
}

```

```

//-----
void DisableWDT(void)
{
    unsigned char bBuf;

    Set_F81964_LD(0x07);                 //switch to logic device 7

    bBuf = Get_F81964_Reg(0xFA);
    bBuf &= ~0x01;
    Set_F81964_Reg(0xFA, bBuf);         //disable WDTO output

    bBuf = Get_F81964_Reg(0xF5);
    bBuf &= ~0x20;
    bBuf |= 0x40;
    Set_F81964_Reg(0xF5, bBuf);         //disable WDT
}

```

```
//-----
```

```
//-----
```

```
//
```

```
// THIS CODE AND INFORMATION IS PROVIDED "AS IS" WITHOUT WARRANTY OF ANY
```

```

// KIND, EITHER EXPRESSED OR IMPLIED, INCLUDING BUT NOT LIMITED TO THE
// IMPLIED WARRANTIES OF MERCHANTABILITY AND/OR FITNESS FOR A PARTICULAR
// PURPOSE.
//
//-----
#include "F81964.H"
#include <dos.h>
//-----
unsigned int F81964_BASE;
void Unlock_F81964 (void);
void Lock_F81964 (void);
//-----
unsigned int Init_F81964(void)
{
    unsigned int result;
    unsigned char ucDid;

    F81964_BASE = 0x4E;
    result = F81964_BASE;

    ucDid = Get_F81964_Reg(0x20);
    if (ucDid == 0x07)                //Fintek 81964
    {
        goto Init_Finish;
    }

    F81964_BASE = 0x2E;
    result = F81964_BASE;

    ucDid = Get_F81964_Reg(0x20);
    if (ucDid == 0x07)                //Fintek 81964
    {
        goto Init_Finish;
    }

    F81964_BASE = 0x00;
    result = F81964_BASE;

Init_Finish:
    return (result);
}
//-----
void Unlock_F81964 (void)
{
    outputb(F81964_INDEX_PORT, F81964_UNLOCK);
    outputb(F81964_INDEX_PORT, F81964_UNLOCK);
}
//-----
void Lock_F81964 (void)
{
    outputb(F81964_INDEX_PORT, F81964_LOCK);
}
//-----
void Set_F81964_LD( unsigned char LD)
{
    Unlock_F81964();
    outputb(F81964_INDEX_PORT, F81964_REG_LD);
    outputb(F81964_DATA_PORT, LD);
    Lock_F81964();
}
//-----

```

```
void Set_F81964_Reg( unsigned char REG, unsigned char DATA)
{
    Unlock_F81964();
    outportb(F81964_INDEX_PORT, REG);
    outportb(F81964_DATA_PORT, DATA);
    Lock_F81964();
}
//-----
unsigned char Get_F81964_Reg(unsigned char REG)
{
    unsigned char Result;
    Unlock_F81964();
    outportb(F81964_INDEX_PORT, REG);
    Result = inportb(F81964_DATA_PORT);
    Lock_F81964();
    return Result;
}
//-----

//-----
//
// THIS CODE AND INFORMATION IS PROVIDED "AS IS" WITHOUT WARRANTY OF ANY
// KIND, EITHER EXPRESSED OR IMPLIED, INCLUDING BUT NOT LIMITED TO THE
// IMPLIED WARRANTIES OF MERCHANTABILITY AND/OR FITNESS FOR A PARTICULAR
// PURPOSE.
//
//-----
#ifndef F81964_H
#define F81964_H                1
//-----
#define F81964_INDEX_PORT      (F81964_BASE)
#define F81964_DATA_PORT      (F81964_BASE+1)
//-----
#define F81964_REG_LD          0x07
//-----
#define F81964_UNLOCK          0x87
#define F81964_LOCK            0xAA
//-----
unsigned int Init_F81964(void);
void Set_F81964_LD( unsigned char);
void Set_F81964_Reg( unsigned char,
unsigned char); unsigned char
Get_F81964_Reg( unsigned char);
//-----
#endif // F81964_H
```

## D. Onboard Connector Reference Types

Function	Connector Name	Onboard Type	Mating Type
eDP Connector	CN1	I-PEX 20374-030E-31	I-PEX 20380-030T
Console COM1 RS-232/422/485 Port	CN7	TechBest SM40D1P1122M31NP	D-SUB 9P (female)
LCD Backlight Connector	J2	JST B4B-PH-K-S	JST PHR-4.
LVDS Connector	J1, J3	Hirose DF20G-20DP-1V	Hirose DF20A-20DS-1C
Audio Connector	J4	Hirose DF11-12DP-2DSA	Hirose DF11-12DS-2C
USB 2.0 Connector	J8	Hirose DF11-8DP-2DSA	Hirose DF11-8DS-2C
Amplifier Connector	J6	JST B4B-PH-K-S	JST PHR-4.
SATA HDD Power Connector	J11	JST B4B-XH-A	JST XHP-4
Front Panel Connector	J13	Dupon 2.54 mm-pitch pin header (Male)	Dupon 2.54 mm-pitch (Female)
COM2 / COM3 / COM4 RS-232 Port	J18, J17, J14	Hirose DF11-10DP-2DSA	Hirose DF11-10DS-2C
Digital I/O Connector	J19	Dupon 2.00 mm-pitch pin header (Male)	Dupon 2.00 mm-pitch (Female)
DC Power Input Connector	J20	JST B2P-VH	JST VHR-2N
Battery Connector	BAT1	Molex 53047-0210	Molex 51021-0200