

CM1202-991

Expandable System with IBASE MI991AF Mini-ITX Motherboard

User Manual

Version 1.0
(January 2026)



Copyright

© 2026 IBASE Technology, Inc. All rights reserved.

No part of this publication may be reproduced, copied, stored in a retrieval system, translated into any language, or transmitted in any form or by any means, electronic, mechanical, photocopying, or otherwise, without the prior written consent of IBASE Technology, Inc. (hereinafter referred to as “IBASE”).

Disclaimer

IBASE reserves the right to make changes and improvements to the products described in this document without prior notice. Every effort has been made to ensure the information in the document is correct; however, IBASE does not guarantee this document is error-free.

IBASE assumes no liability for incidental or consequential damages resulting from misapplication or inability to use the product or the information contained herein, nor for any infringements of rights of third parties, which may result from its use.

Trademarks

All the trademarks, registrations, and brands mentioned herein are used for identification purposes only and may be trademarks and/or registered trademarks of their respective owners.

Compliance



This product has passed CE tests for environmental specifications and limits. This product is in accordance with the directives of the European Union (EU). If users modify and/or install other devices in this equipment, the CE conformity declaration may no longer apply.



This product has been tested and found to comply with the limits for a Class A device, pursuant to Part 15 of the FCC Rules. These limits are designed to provide reasonable protection against harmful interference in a commercial installation. This equipment generates, uses, and can radiate radio frequency energy and, if not installed and used in accordance with the manufacturer's instructions, may cause harmful interference to radio communications.

WEEE



This product must not be disposed of as normal household waste, in accordance with the EU directive for Waste Electrical and Electronic Equipment (WEEE – 2012/19/EU). Instead, it should be disposed of by returning it to a municipal recycling collection point. Check local regulations for disposal of electronic products.

Green IBASE



This product is compliant with the current RoHS 2 restrictions and prohibits use of the following substances in concentrations exceeding 0.1% by weight (1000 ppm) except for cadmium, limited to 0.01% by weight (100 ppm).

- Hexavalent chromium: 1,000 ppm
- Polybrominated biphenyls (PBBs): 1,000 ppm
- Polybrominated diphenyl ethers (PBDEs): 1,000 ppm
- Cadmium: 100 ppm
- Mercury: 1,000 ppm
- Lead: 1,000 ppm
- Bis(2-ethylhexyl) phthalate (DEHP): 1,000 ppm
- Butyl benzyl phthalate (BBP): 1,000 ppm
- Dibutyl phthalate (DBP): 1,000 ppm
- Diisobutyl phthalate (DIBP): 1,000 ppm

Important Safety Information

Carefully read the precautions before using the device.

Environmental conditions:

- Place the device on a stable, level surface to prevent it from falling, causing serious damage.
- Slots and openings on the chassis are for ventilation. Do not block or cover these openings. Make sure you leave plenty of space around the device for ventilation. Never insert objects of any kind into the ventilation openings.

Care for your iBASE products:

- Before cleaning the device, turn it off and unplug all cables such as power in case a small amount of electrical current may still flow.
- Use neutral cleaning agents or diluted alcohol to clean the device chassis with a cloth. Then wipe the chassis with a dry cloth.
- Vacuum the dust with a computer vacuum cleaner to prevent the air vent or slots from being clogged.

WARNING

Attention during use:

- Do not use this product near water.
- Do not spill water or any other liquids on your device.
- Do not place heavy objects on the top of the device.
- Operate this device from the type of power indicated on the marking label. If you are not sure of the type of power available, consult your distributor or local power company.
- Do not walk on the power cord or allow anything to rest on it.
- If you use an extension cord, make sure that the total ampere rating of the product plugged into the extension cord does not exceed its limits.

Avoid Disassembly

Do not disassemble, repair, or modify the device. Disassembly, modification, or any attempt at repair could generate hazards and cause damage to the device, even bodily injury or property damage, and will void any warranty.

Danger of explosion

Replace only with the same or an equivalent type recommended by the manufacturer. Dispose of used batteries according to local regulations.

Warranty Policy

- IBASE standard products:

24-month (2-year) warranty from the date of shipment. If the date of shipment cannot be ascertained, the product serial numbers can be used to determine the approximate shipping date.

- 3rd-party parts:

12-month (1-year) warranty from delivery for the 3rd-party parts that are not manufactured by IBASE, such as CPU, memory, SSD/HDD, power adapter, panel and touchscreen.

* *Products that fail due to misuse, accident, improper installation or unauthorized repair shall be treated as out of warranty and customers shall be billed for repair and shipping charges.*

Technical Support & Services

1. Visit the IBASE website at www.ibase.com.tw to find the latest information about the product.
2. If you need any further assistance from your distributor or sales representative, prepare the following information of your product and elaborate upon the problem.
 - Product model name
 - Product serial number
 - Detailed description of the problem
 - The error messages in text or in screenshots if there is any
 - The arrangement of the peripherals
 - Software in use (such as OS and application software, including the version numbers)
3. If repair service is required, you can download the RMA form at the website of IBASE. Fill out the form and contact your distributor or sales representative.

Table of Contents

Chapter 1	General Information.....	1
1.1	Introduction	2
1.2	Features.....	2
1.3	Specifications.....	3
1.4	Product View.....	5
1.5	Dimensions	8
Chapter 2	Hardware Installation	9
2.1	Essential Installations.....	10
2.1.1	System (Factory-Assembled State)	10
2.1.2	Wall-Mount Bracket Removal (If Installed).....	11
2.1.3	System Cover Removal	11
2.1.4	PCI Slot Bracket Removal	12
2.1.5	Internal Layout View	13
2.1.6	Memory Installation / Replacement.....	14
2.1.7	Storage Installation / Replacement (2.5" HDD / SSD).....	15
2.1.8	Pinout for DC Power Input Connector	16
2.2	Setting the Jumpers	17
2.3	Jumper & Connector Locations on Motherboard	18
2.4	Jumpers Quick Reference.....	19
2.4.1	JBAT1: Clear CMOS Contents	19
2.4.2	JBAT2: Clear RTC Contents.....	20
2.4.3	JP1, JP2: PCI-E x16 Mode Selection.....	21
2.4.4	JP3: Flash Descriptor Security Override (Factory use only)	22
2.5	Connectors Quick Reference	23
2.5.1	J2: ATX 12V Power Connector	24
2.5.2	J3, J4: DDR4 SO-DIMM Connector	25
2.5.3	J5: ATX Power Supply Connector.....	26
2.5.4	J7: Digital I/O Connector	27
2.5.5	J9: Mini PCI-E Connector	28
2.5.6	J10: Mini PCI-E Connector (Supports mSATA Function)	28
2.5.7	J11: ACPI Status LED	29
2.5.8	J12: SPI Flash Connector (Factory use only).....	30
2.5.9	J13: Debug 80 Port Connector (Factory use only)	30
2.5.10	J14: Battery Connector	31
2.5.11	J15: USB2.0 Connectors	32
2.5.12	J16: Audio Pin Header for Chassis Front Panel	33

2.5.13	J17, J18: COM3/4 RS232 Serial Ports.....	34
2.5.14	J19: Front Panel Function Connector	35
2.5.15	CPU_FAN1: CPU Fan Power Connector	36
2.5.16	SYS_FAN1: System Fan1 Power Connector	37
2.5.17	PCIE1: PCI-E X16 Slot	38
Chapter 3 Driver Installation		39
3.1	Introduction	40
3.2	Intel® Chipset Software Installation Utility	40
3.3	VGA Drivers Installation	42
3.4	Realtek HD Audio Driver Installation	44
3.5	LAN Drivers Installation.....	46
3.6	Intel® Management Engine Interface	49
3.7	Intel® USB 3.0 Drivers	51
Chapter 4 BIOS Setup.....		54
4.1	Introduction	55
4.2	BIOS Setup.....	55
4.3	Main Settings	56
4.4	Advanced Settings	57
4.5	Chipset Settings.....	66
4.6	Security Settings	70
4.7	Boot Settings.....	71
4.8	Save & Exit Settings.....	72
Appendix		73
	I/O Port Address Map	74
	Watchdog Timer Configuration	75

Chapter 1

General Information

The information provided in this chapter includes:

- Features
- Specifications
- Product View
- Dimensions

1.1 Introduction

The CMI202-991 is a compact industrial embedded system designed for reliable performance in automation, control, and edge-computing environments. Powered by 6th-generation Intel® Core™ processors and the Intel® Q170 chipset, it supports up to 32GB of DDR4 memory and dual 2.5" SATA storage for fast, stable operation. The system offers rich I/O connectivity, including multiple serial ports, USB 3.0, dual Gigabit LAN, and triple independent display outputs (HDMI, DVI-D, DisplayPort). Its rugged steel chassis, wide operating temperature range, and 24V DC industrial power input make it ideal for factory, kiosk, and machine-vision applications.



1.2 Features

- 6th Gen Intel® Core™ i7/i5/i3 / Pentium® / Celeron® DT Processors
- Dual-channel memory, up to 32GB DDR4
- 4x DB9, 1x GPIO
- Supports DVI-D, HDMI and DisplayPort
- Removable 2.5" storage (supports RAID 0/1)
- Supports Intel® iAMT(11.0) and TPM (1.2)

1.3 Specifications

Product Name	<i>CMI202-991</i>
Mainboard	MI991AF
System Type	Mini-ITX Expandable System
CPU Type	6th Gen Intel® Core™ i7 / i5 / i3 / Pentium® / Celeron® Desktop Processors
PCH	Intel® Q170
System Speed	i7-6700 (3.4GHz ~ 4.0GHz)
Memory	2x 8GB DDR4-2400 SO-DIMM, Max. 32GB
Front-side Panel I/O	N/A
Rear-side Panel I/O	<ul style="list-style-type: none"> • 1x 2-pin DC input for 24V (±10%) • 1x 2-pin DC output for 12V (±10%) • 1x Power on/off button • 1x Reset button • 1x Power LED, 1 x HDD LED • 1x DB9 (GPIO 4-in / 4-out) • 3x RS-232 for COM2–COM4 (2 ports via pin header) • 1x RS-232/422/485 for COM1 • 6x USB 3.0, 2x USB 2.0 • 2x System fans • 2x RJ-45 LAN ports • 1x Audio port (Line-in / Line-out / Mic-in) • 1x Speaker out (6W) via ID107 (optional) • 1x DVI-D, 1x HDMI, 1x DisplayPort
Storage Interface	2 x 2.5" SATA HDD or SSD (removable)
RAID Support	RAID 0 / RAID 1
Expansion Slot	1 x PCIe x16 expansion slot Add-on card size supports up to 106mm x 200mm
Power Supply	Industrial 250W DC switching power supply
Input Voltage	Direct 24V DC (±10%), 18A
Construction	SECC
Chassis Color	Black
Mounting Type	Wall mount / Desktop
Dimensions (mm)	345 (W) x 240 (D) x 100 (H)
Dimensions (inch)	13.5" (W) x 9.44" (D) x 3.93" (H)
Weight	4.4 kg

Environment	
Operating Temperature	0°C ~ 45°C (32°F ~ 113°F)
Storage Temperature	-20°C ~ 80°C (-4°F ~ 176°F)
Relative Humidity	5% ~ 90% @ 45°C (non-condensing)
Vibration (Operating)	0.25 grms / 5–500 Hz / random
Vibration (Non-operating)	1.0 grms / 5–500 Hz / random
Certification	CE / LVD / FCC Class B (Pre-scan only)

All specifications are subject to change without prior notice.

For detailed MB specifications, refer to the respective user manuals on our website.



1.4 Product View

Rear View



Rear-side Panel I/O (see figure above)

- 1x 2-pin DC input for 24V ($\pm 10\%$) (left side)
- 1x 2-pin DC output for 12V ($\pm 10\%$) (left side)
- 1x RS-232/422/485 for COM1 (rear I/O plate)
- 6x USB 3.0, 2x USB 2.0 (rear I/O plate)
- 2x RJ-45 LAN ports (rear I/O plate)
- 1x Audio port (Line-in / Line-out / Mic-in) (rear I/O plate)
- 1x DVI-D, 1x HDMI, 1x DisplayPort (rear I/O plate)
- 3x RS-232 for COM2–COM4 (2 ports via header) (COM2 rear I/O plate)
- 1x Power on/off button (right side)
- 1x Reset button (right side)
- 1x Power LED, 1x HDD LED (right side)
- 1x DB9 (GPIO 4-in / 4-out) (upper right)
- 1x Speaker out (6W) via ID107 (optional, internal)
- 2x System fans (above I/O plate)

Front View (with wallmount bracket installed)



Top View



1.5 Dimensions

Unit: mm

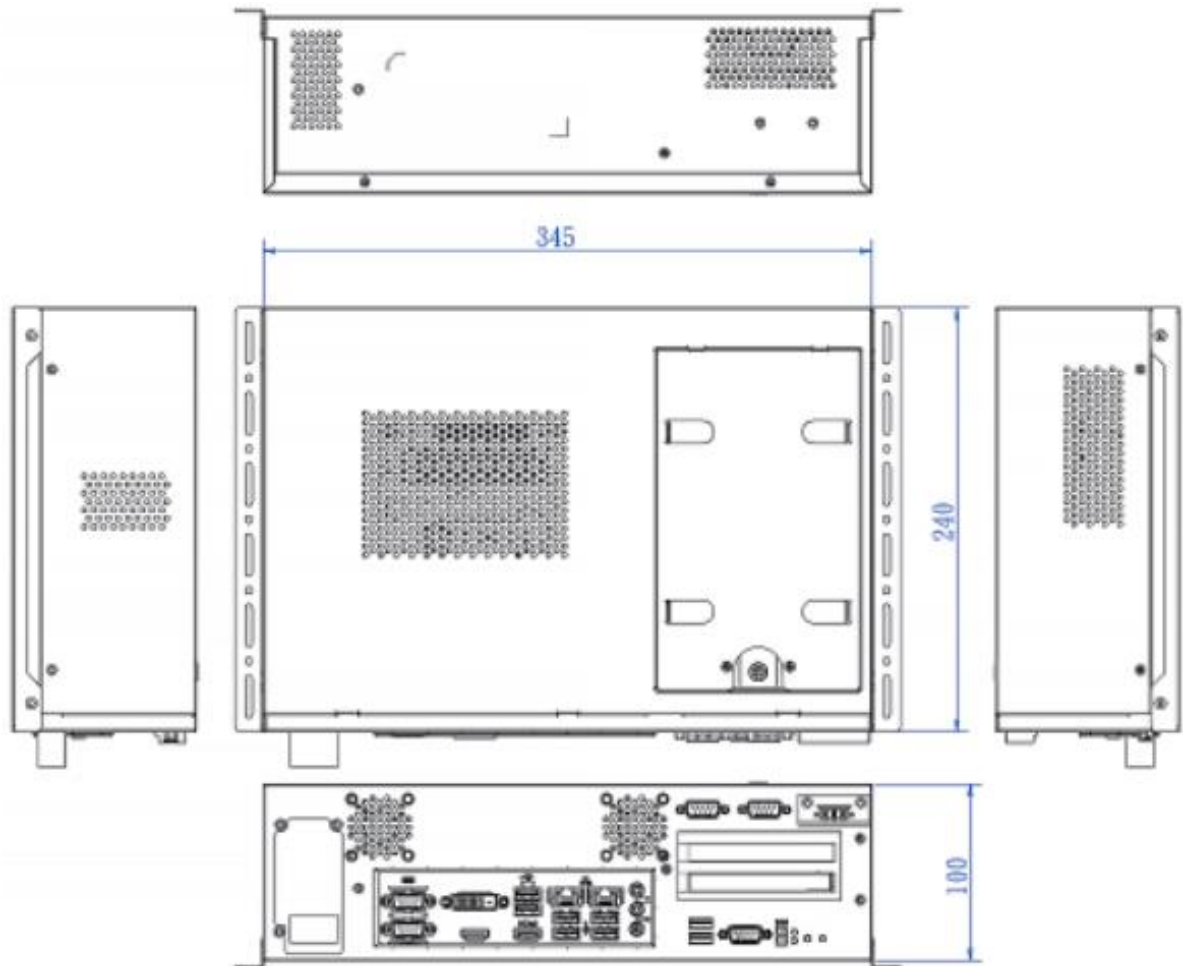

Chapter 2

Hardware Installation

The information provided in this chapter includes:

- Essential installations: memory and storage
- Expansion card, and wall mount installation

2.1 Essential Installations

This section describes the procedures required to install or replace internal components of the CMI202-991 system. Follow the steps in the order provided.

2.1.1 System (Factory-Assembled State)

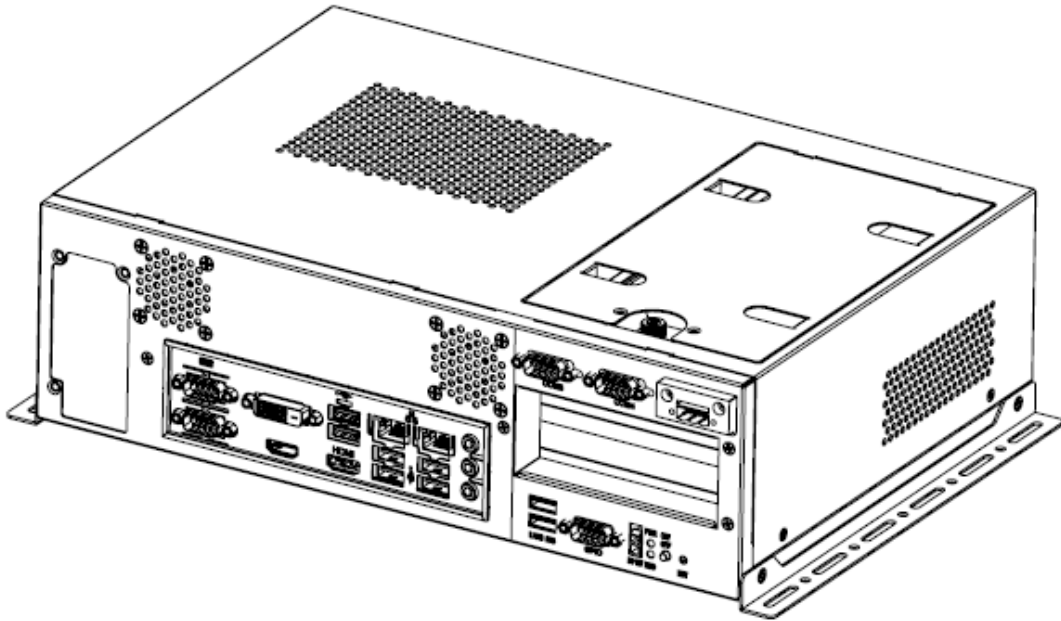

Figure 2-1. CMI202-991 Fully Assembled System (Rear View)

This figure shows the system in its factory-assembled condition with:

- System cover installed
- PCI slot brackets installed
- Wall-mount brackets attached (if applicable)

No internal components are accessible in this state.

2.1.2 Wall-Mount Bracket Removal (If Installed)

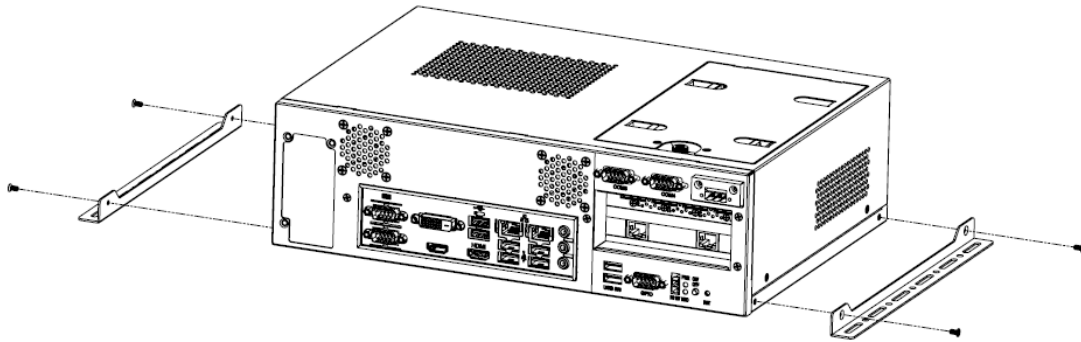

Figure 2-2. Wall-Mount Bracket Removal

Steps:

1. Power off the system and disconnect all cables.
2. Turn the system upside down.
3. Remove **two (2) screws from the left wall-mount bracket.**
4. Remove **two (2) screws from the right wall-mount bracket.**
5. Remove both wall-mount brackets and retain the screws for reinstallation.

Total screws removed in this step: 4

2.1.3 System Cover Removal

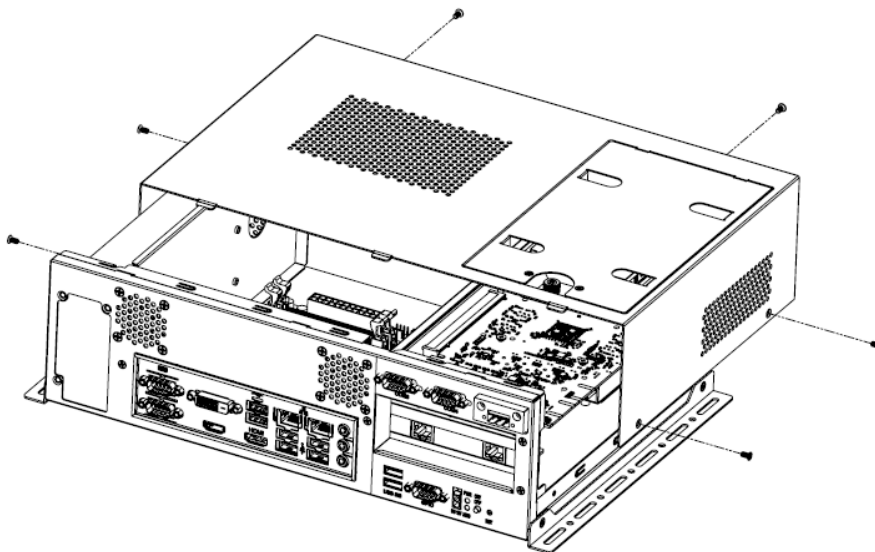

Figure 2-3. System Cover Removal

Steps:

1. Place the system upright.
2. Locate the screws securing the top system cover.
3. Remove **all system cover retaining screws.**
4. Lift the system cover upward and remove it from the chassis.

Note: Removing the system cover provides access to all internal components.

2.1.4 PCI Slot Bracket Removal

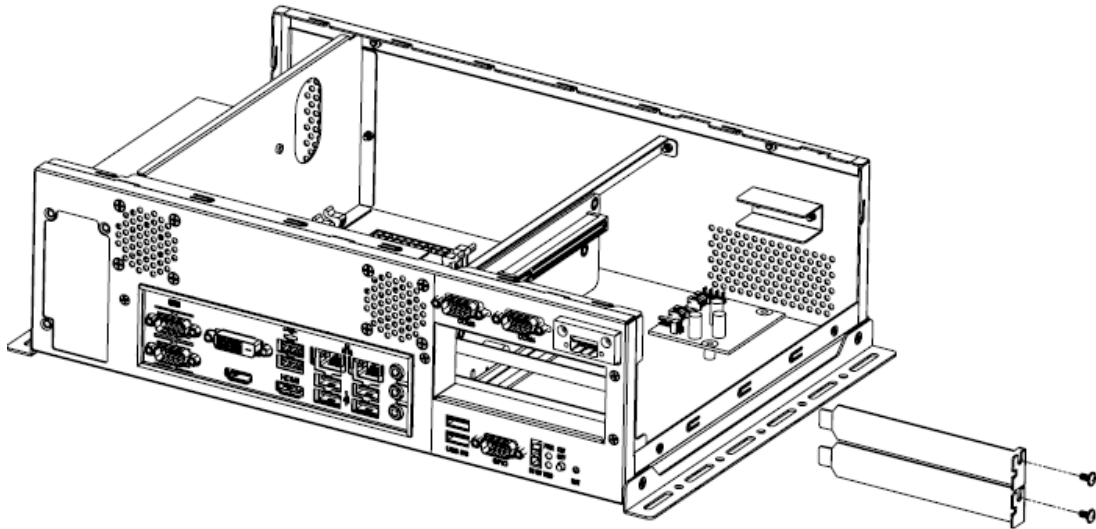

Figure 2-4. PCI Slot Bracket Removal

Steps:

1. Locate the two PCI slot brackets on the rear panel.
2. Remove **one (1) screw from each PCI slot bracket.**
3. Remove the PCI slot brackets corresponding to the PCIe x16 expansion slot.

Total screws removed in this step: 2

Note: Keep unused PCI brackets installed to maintain EMI protection.

2.1.5 Internal Layout View

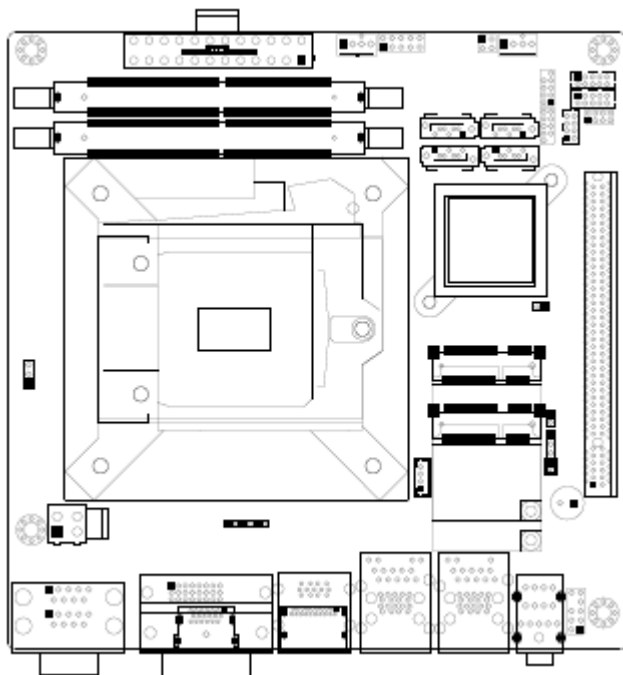

Figure 2-5. Internal Component (board) Layout

This figure identifies the following components:

- DDR4 SO-DIMM memory slots
- 2.5" SATA storage bays
- PCIe x16 expansion slot
- MI991AF Mini-ITX motherboard

2.1.6 Memory Installation / Replacement



Figure 2-6. DDR4 SO-DIMM Memory Installation Steps:

1. Locate the DDR4 SO-DIMM slots on the motherboard.
2. Align the key of your memory module with that on the memory slot and insert the module slantwise.
3. Gently push the module in an upright position until the clips of the slot click to hold the module in place when the module touches the bottom of the slot.

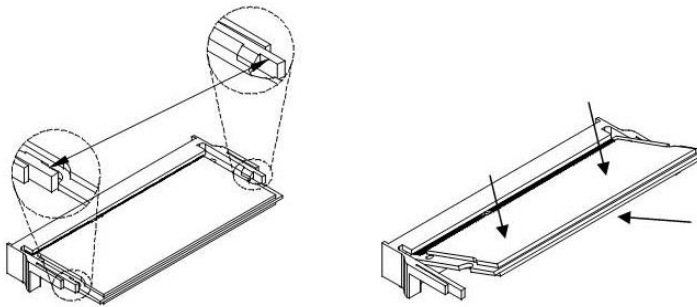

To remove the module, press the clips outwards with both hands.

2.1.7 Storage Installation / Replacement (2.5" HDD / SSD)



Figure 2-7

Steps:

1. Locate the external 2.5" storage tray.
2. Remove one (1) external fixing screw that locks the storage tray.
3. Pull the storage tray completely out of the chassis.
4. Turn the tray over to access the drive mounting side.
5. Install the HDD first (bottom position). Place the 2.5" HDD into the lower/bottom mounting position on the tray. Secure the HDD using four (4) screws (B30-B x4).
6. Install the SSD second (top position). Place the 2.5" SSD onto the upper/top mounting position above the HDD. Secure the SSD using four (4) screws **(B30-B x4)**.
7. Reinsert the storage tray into the chassis and secure it with the original external fixing screw.

2.1.8 Pinout for DC Power Input Connector

- DC Power Input (terminal block)

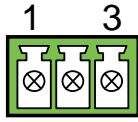

Pin	Assignment	Pin	Assignment
1	GND	3	+12V
2	Chassis GND		

2.2 Setting the Jumpers

Set up and configure your system by using jumpers for various settings and features according to your needs and applications. Contact your supplier if you have doubts about the best configuration for your use.

Jumpers are short-length conductors consisting of several metal pins with a non-conductive base mounted on the circuit board. Jumper caps are used to have the functions and features enabled or disabled. If a jumper has 3 pins, you can connect either PIN1 to PIN2 or PIN2 to PIN3 by shorting.

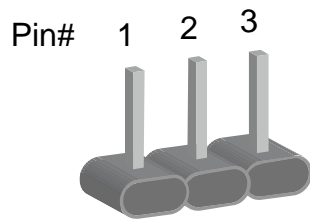

A 3-pin jumper

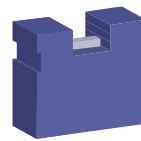

A jumper cap

Refer to the illustration below to set jumpers.

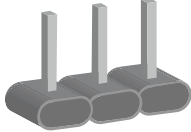
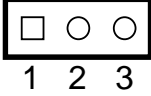
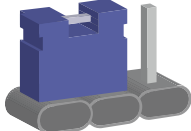
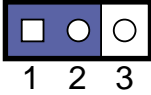
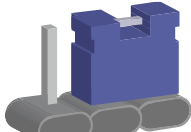
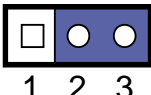
Pin closed	Oblique view	Schematic illustration in the manual
Open		
1-2		
2-3		

When two pins of a jumper are encased in a jumper cap, this jumper is **closed**, i.e. turned **On**.

When a jumper cap is removed from two jumper pins, this jumper is **open**, i.e. turned **Off**.

2.3 Jumper & Connector Locations on Motherboard

Motherboard: MI991

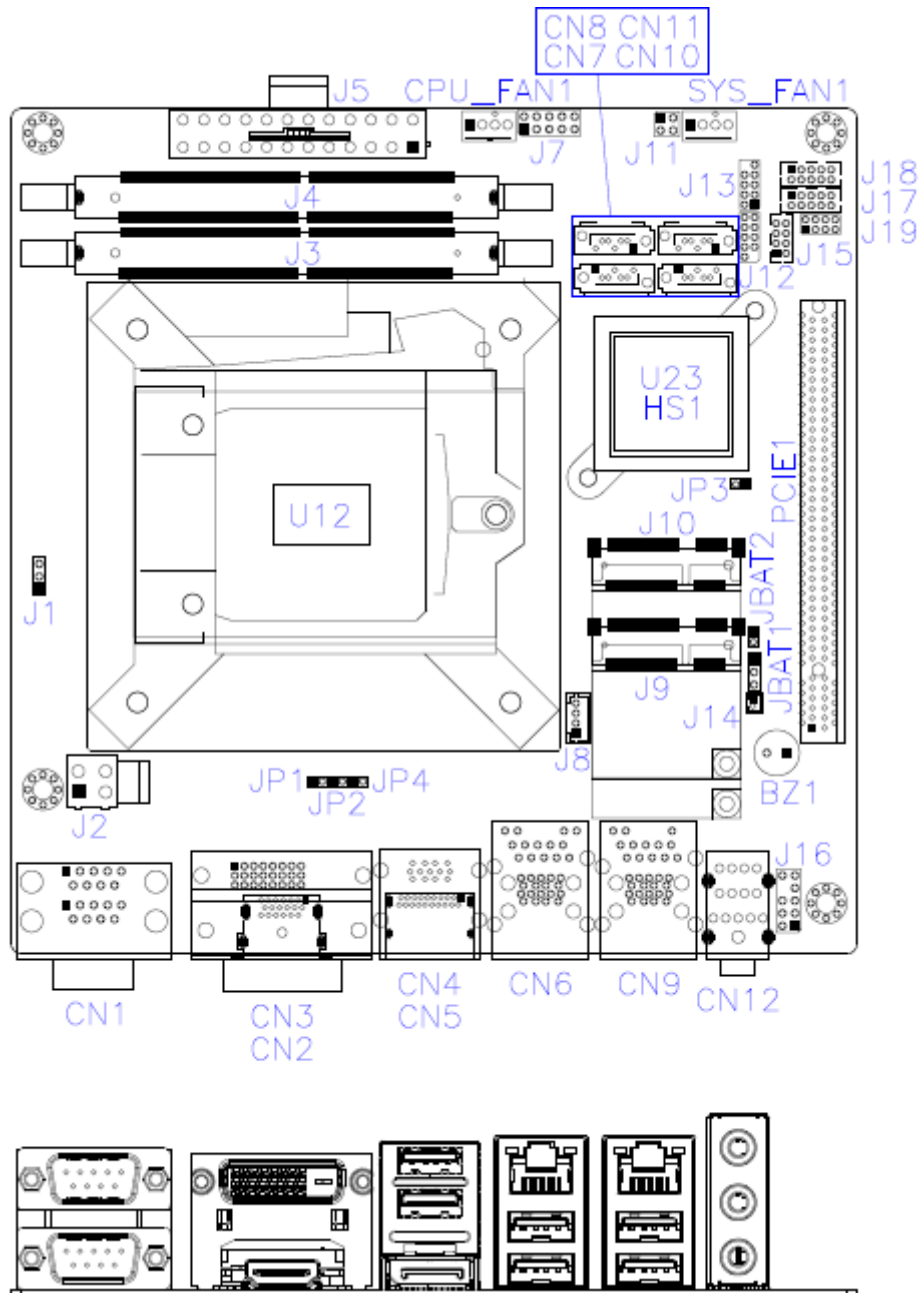

2.4 Jumpers Quick Reference

Connector	Function
JBAT1	Clear CMOS Contents
JBAT2	Clear RTC Contents
JP1, JP2	PCI-E x16 Mode Selection
JP3	Flash Descriptor Security Override (Factory use only)

2.4.1 JBAT1: Clear CMOS Contents

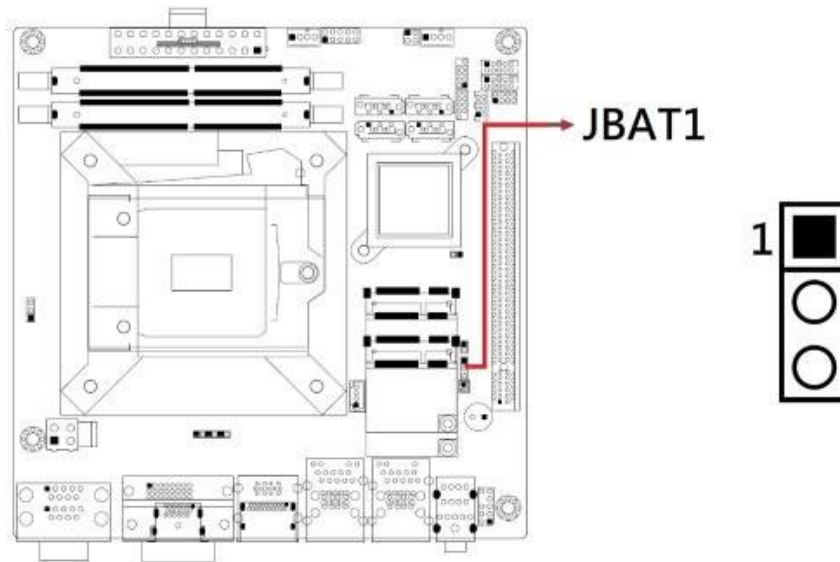

Note: E-CALL 0125-01-203-030

Function	JBAT	Illustration
Normal (default)	Pin 1-2 closed	
Clear CMOS	Pin 2-3 closed	

2.4.2 JBAT2: Clear RTC Contents

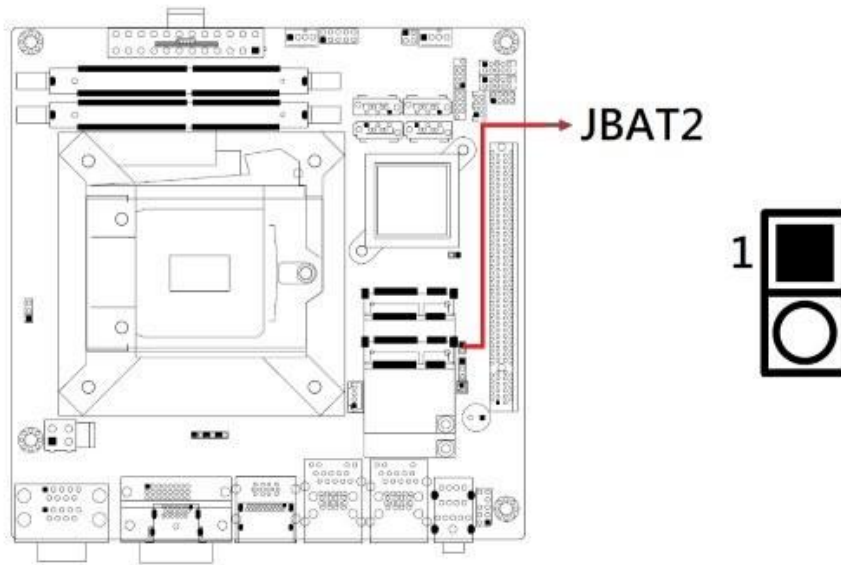

Note: 0195-01-200-020

Function	JBAT2
Normal (default)	Open
Clear RTC	Close

2.4.3 JP1, JP2: PCI-E x16 Mode Selection

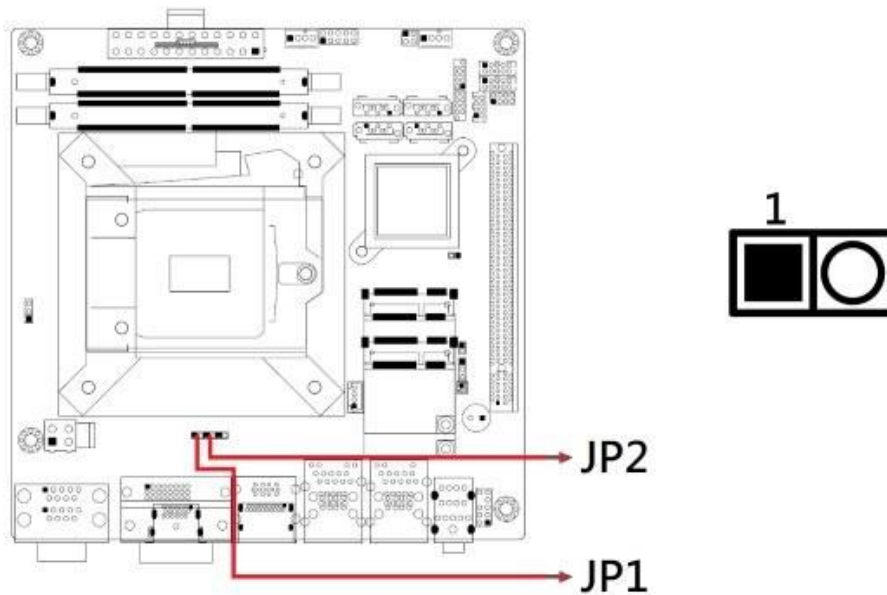

Note: 0195-01-200-020

Pin closed	Function
JP1/Open JP2/Open	1 x16 (default)
JP1/Open JP2/Short	2 x8
JP1/Short JP2/Short	1 x8, 2 x4

2.4.4 JP3: Flash Descriptor Security Override (Factory use only)

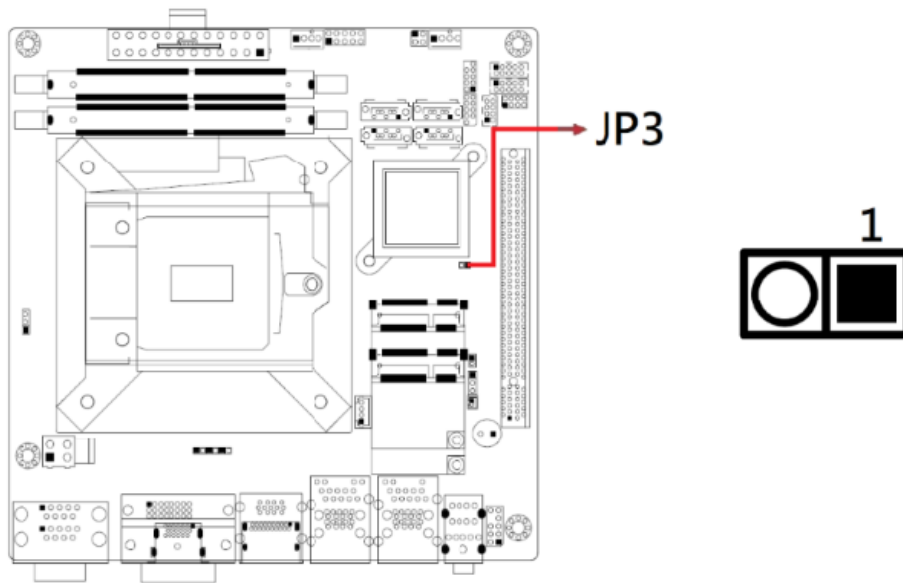

JP3	Flash Descriptor Security Override
Open	Disabled (default)
Close	Enabled

Note: 0195-01-200-020

2.5 Connectors Quick Reference

Connector	Function
CN1	COM1 and COM2 Serial Ports
CN2, CN3	DVI-D and HDMI Connector
CN4, CN5	Display Port + USB 3.0 0/1 Connector
CN6	Gigabit LAN (Intel I219LM/I219V) + USB3.0 2/3
CN7, CN8, CN10, CN11	SATA Connectors
CN9	Gigabit LAN (Intel I211AT) + USB 3.0 4/5
CN12	HD Audio Connector
J2	ATX 12V Power Connector
J3, J4	DDR4 SO-DIMM Connector
J5	ATX Power Supply Connector
J7	Digital I/O Connector
J9	Mini PCI-E Connector
J10	Mini PCI-E Connector
J11	ACPI Status LED
J12	SPI Flash Connector (Factory use only)
J13	Debug 80 Port Connector (Factory use only)
J14	Battery Connector
J15	USB2.0 Connectors
J16	Audio Pin Header for Chassis Front Panel
J17, J18	COM3/4 RS232 Serial Ports
J19	Front Panel Function Connector
CPU_FAN1	CPU Fan Power Connector
SYS_FAN1	System Fan1 Power Connector
PCIE1	PCI-E x16 Slot

2.5.1 J2: ATX 12V Power Connector

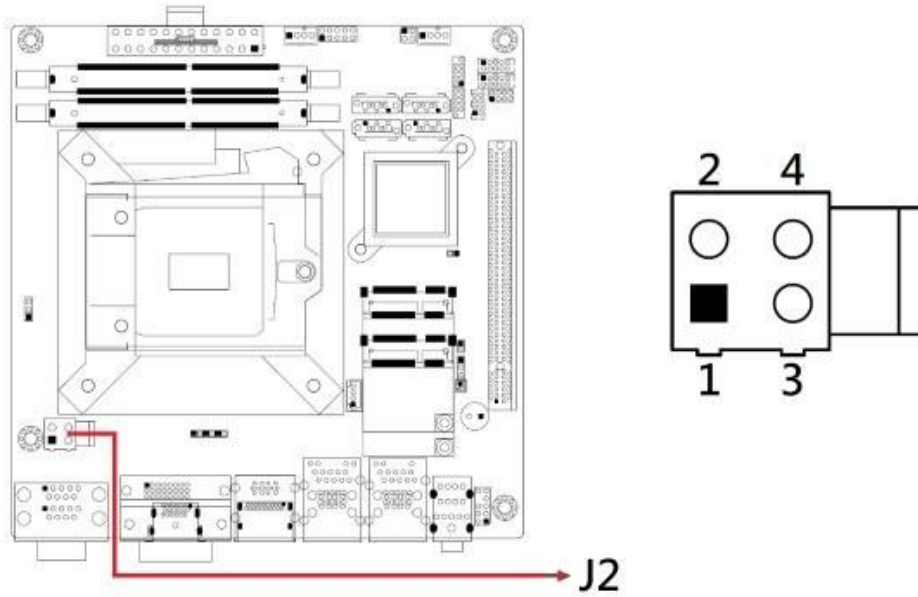

Note: HAOGUO ATX4PT-NY46

Pin	Assignment
1	Ground
2	Ground
3	+12V
4	+12V

2.5.2 J3, J4: DDR4 SO-DIMM Connector

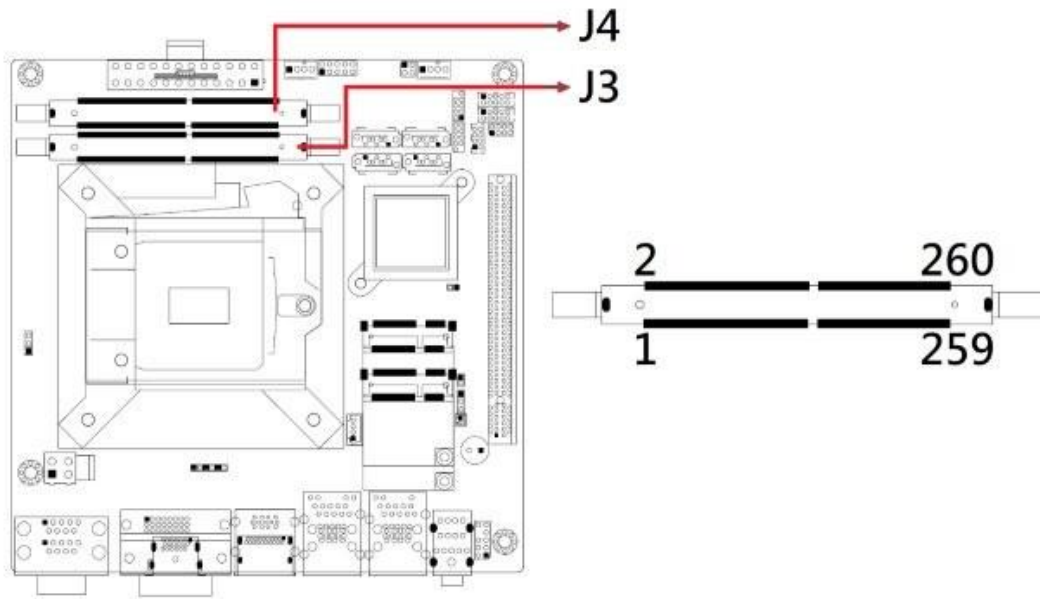

Note: LOTES DDR0075-P001C

2.5.3 J5: ATX Power Supply Connector

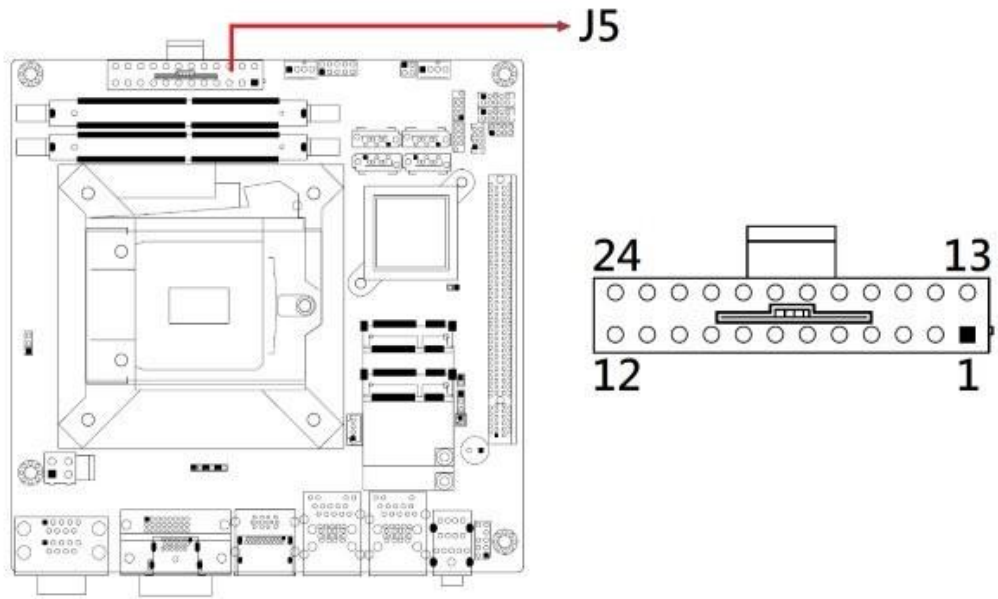

Note: HAOGUO 01-0018-03

Pin	Assignment	Pin	Assignment
13	3.3V	1	3.3V
14	-12V	2	3.3V
15	Ground	3	Ground
16	PS-ON	4	+5V
17	Ground	5	Ground
18	Ground	6	+5V
19	Ground	7	Ground
20	-5V	8	Power good
21	+5V	9	5VSB
22	+5V	10	+12V
23	+5V	11	+12V
24	Ground	12	+3.3V

2.5.4 J7: Digital I/O Connector

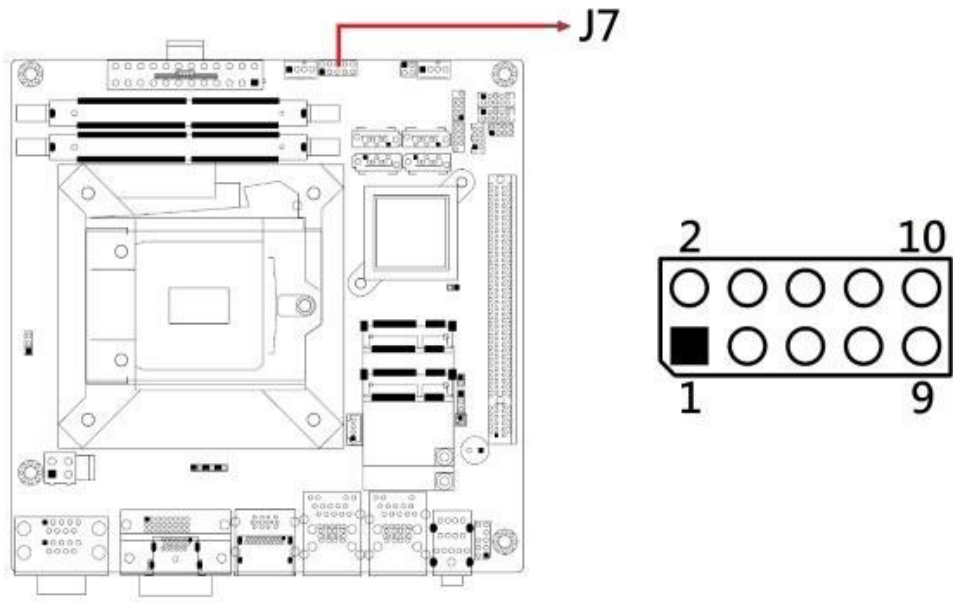

Note: E-CALL 0126-01-203-100

Pin	Assignment	Pin	Assignment
1	GND	2	VCC
3	OUT3	4	OUT1
5	OUT2	6	OUT0
7	IN3	8	IN1
9	IN2	10	IN0

2.5.5 J9: Mini PCI-E Connector

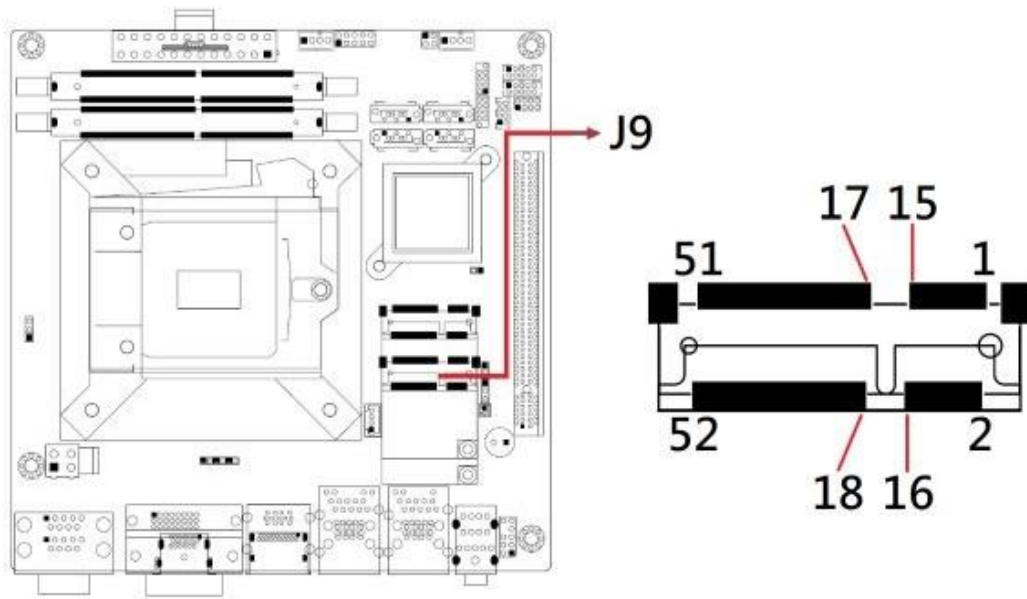

Note: Foxconn AS0B226-S56Q-7H

2.5.6 J10: Mini PCI-E Connector (Supports mSATA Function)

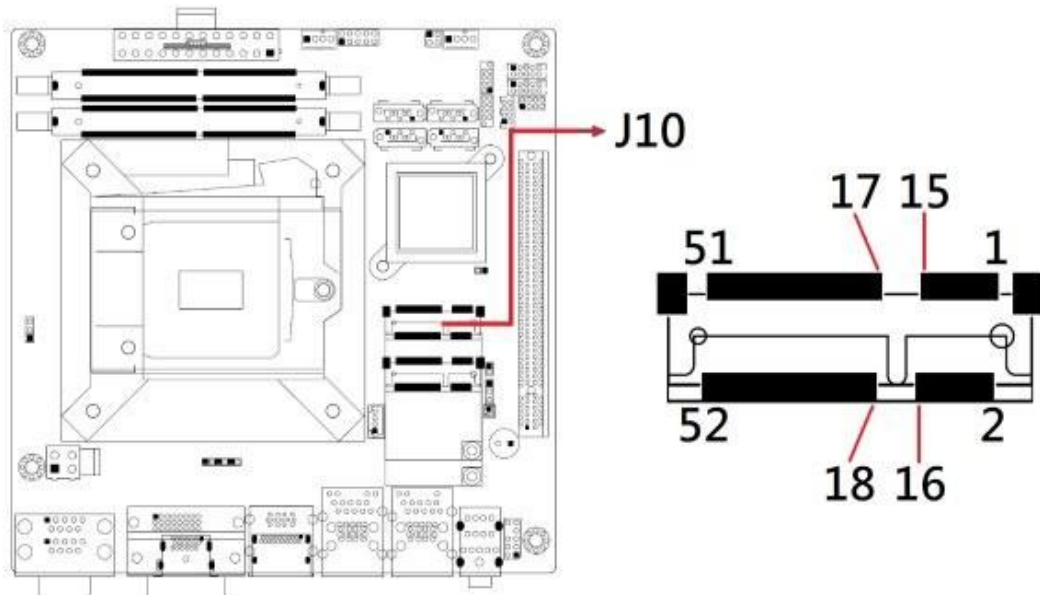

Note: Foxconn AS0B226-S99Q-7H

2.5.7 J11: ACPI Status LED

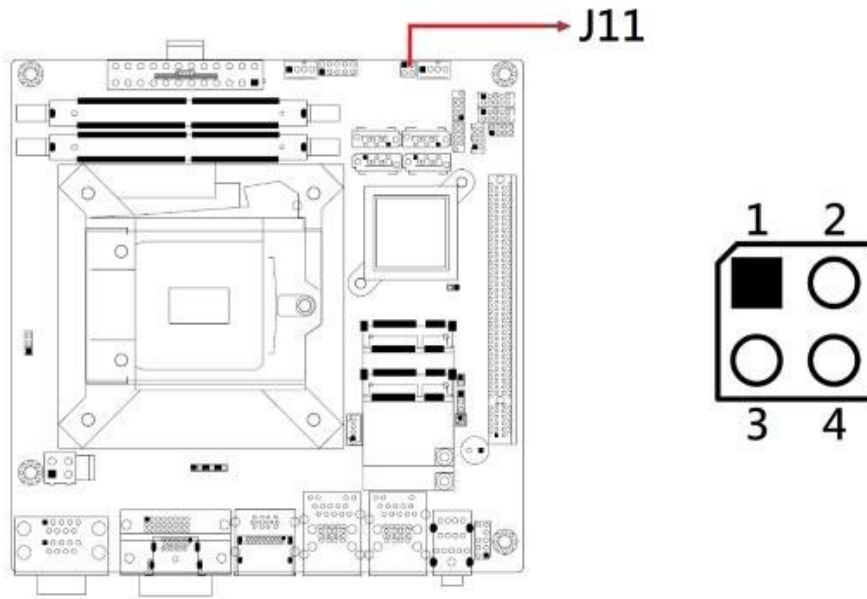

Note: E-CALL 0126-01-203-040

Pin	Assignment
1	+3VDUAL
2	GND
3	+VCC3
4	GND

2.5.8 J12: SPI Flash Connector (Factory use only)

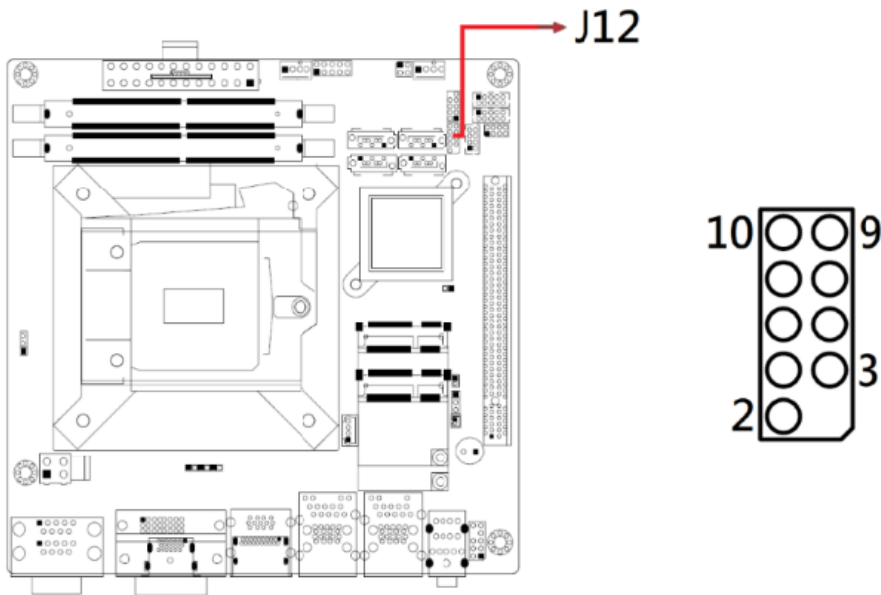

Note: E-CALL 0196-01-2001009

2.5.9 J13: Debug 80 Port Connector (Factory use only)

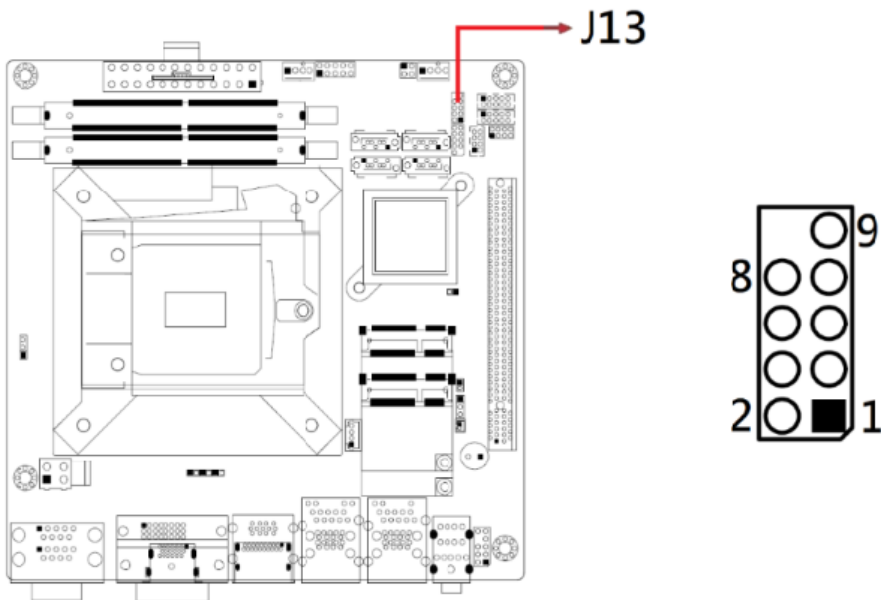

Note: E-CALL 0196-01-2001009

2.5.10 J14: Battery Connector

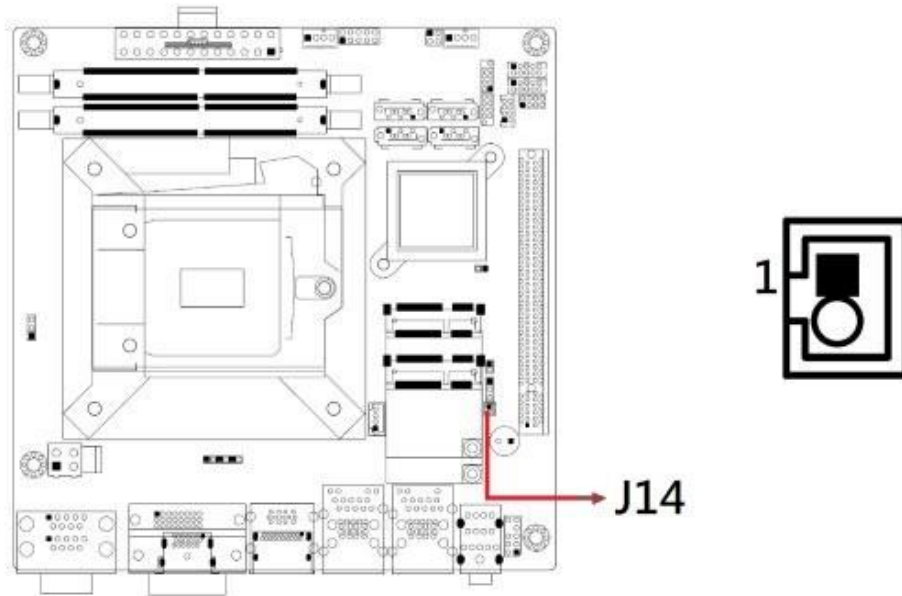

Note: 世均1252-WS2-02-LF

Pin	Assignment
1	Battery+
2	GND

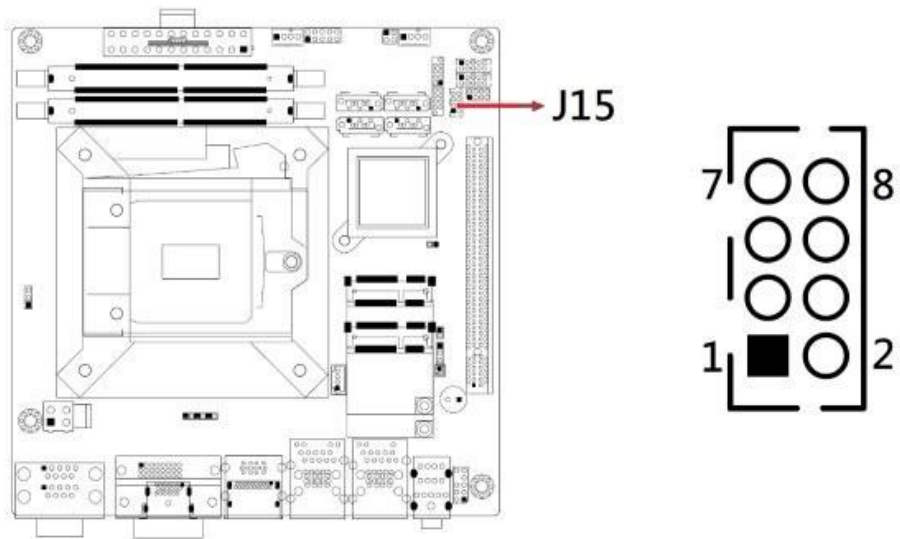
2.5.11 J15: USB2.0 Connectors**Note: HAOGUO DF11-8S-PA66H**

Pin	Assignment	Pin	Assignment
1	VCC	2	Ground
3	D0-	4	D1+
5	D0+	6	D1-
7	Ground	8	VCC

2.5.12 J16: Audio Pin Header for Chassis Front Panel

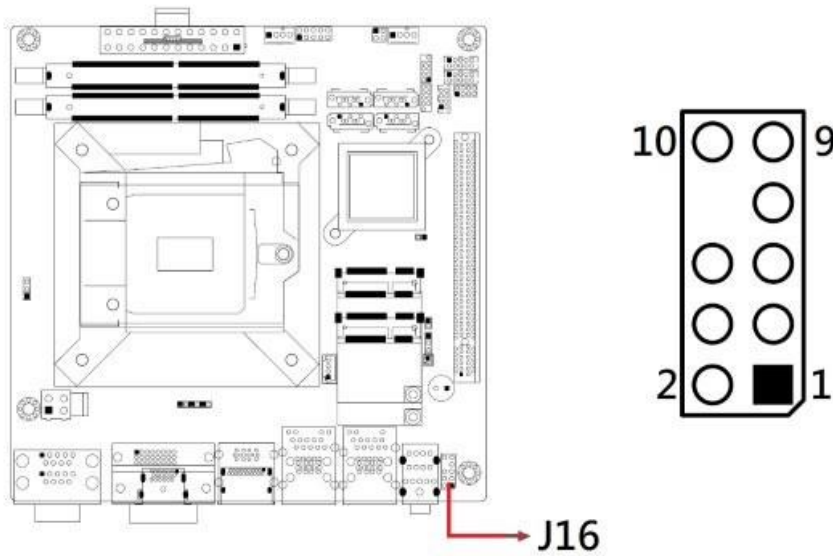

Note: E-CALL 0126-01-2821009

Pin	Assignment	Pin	Assignment
1	MIC IN_L	2	Ground
3	MIC IN_R	4	DET
5	LINE_R	6	Sense Ground
7	Sense	8	Key
9	LINE_L	10	Sense Ground

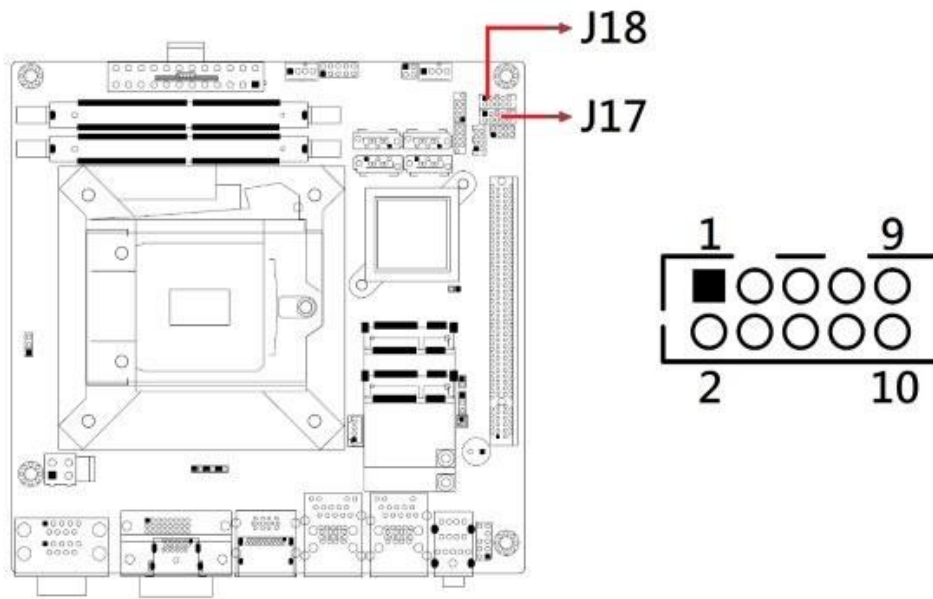
2.5.13 J17, J18: COM3/4 RS232 Serial Ports**Note: HAOGUO DF11-10S-PA66H**

Pin	Assignment	Pin	Assignment
1	DCD#	6	DSR#
2	SIN	7	RTS#
3	SOUT	8	CTS#
4	DTR#	9	RI#
5	GND	X	KEY

2.5.14 J19: Front Panel Function Connector

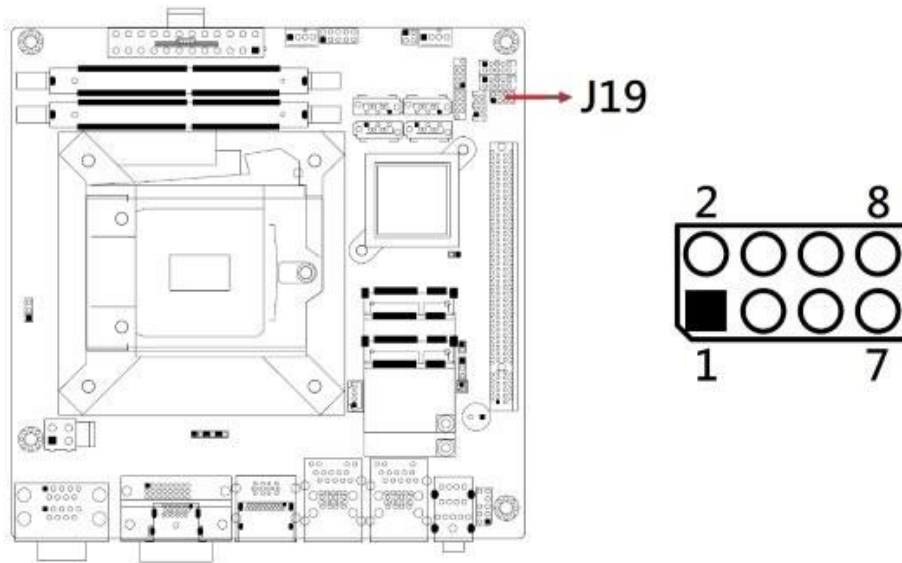

Note: 0196-01-200-080

Pin	Assignment	Pin	Assignment
1	Ground	2	PWR_SW
3	PWR_LED+	4	PWR_LED-(GND)
5	HDD_LED+	6	HDD_LED-
7	Ground	8	Reset

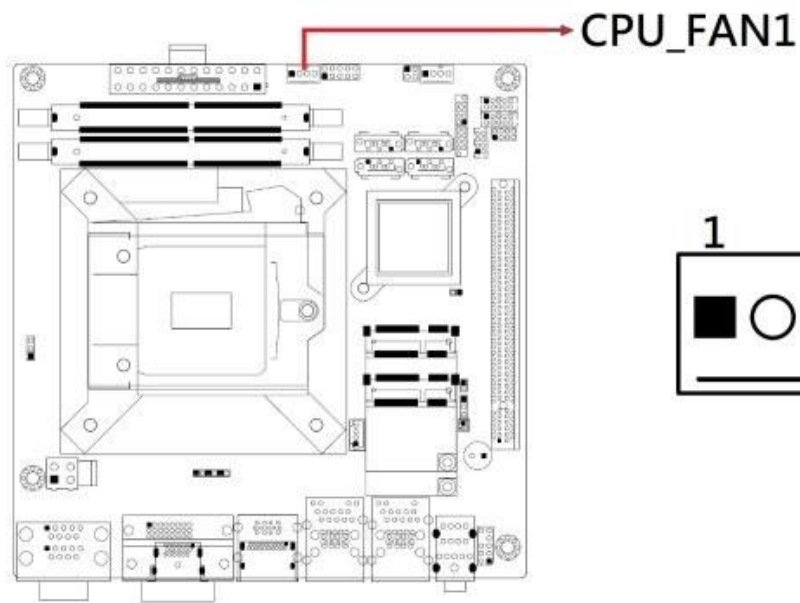
2.5.15 CPU_FAN1: CPU Fan Power Connector**Note: HF27040-M1**

Pin	Assignment
1	Ground
2	+12V
3	Rotation detection
4	Control

2.5.16 SYS_FAN1: System Fan1 Power Connector

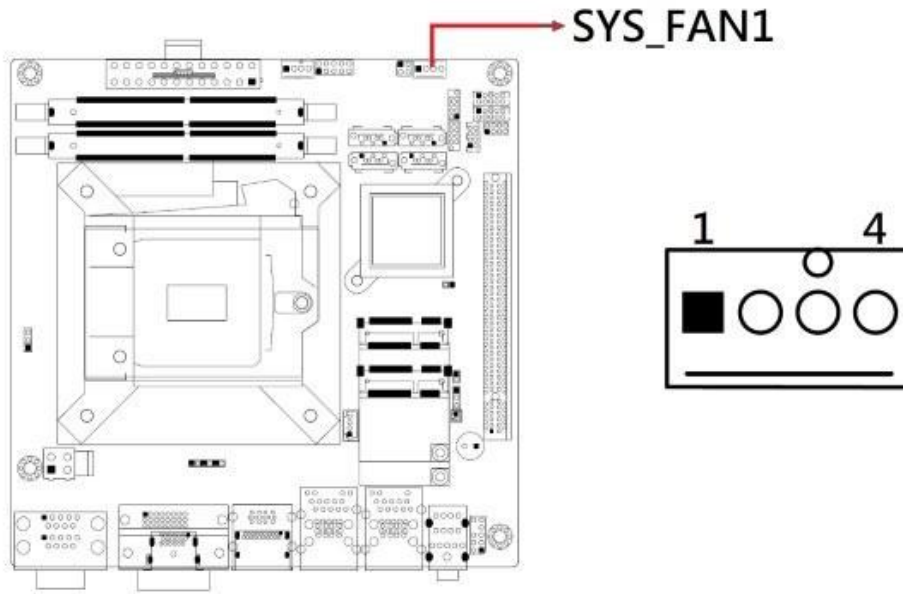

Note: HF27040-M1

Pin	Assignment
1	Ground
2	+12V
3	Rotation detection
4	Control

2.5.17 PCIE1: PCI-E X16 Slot

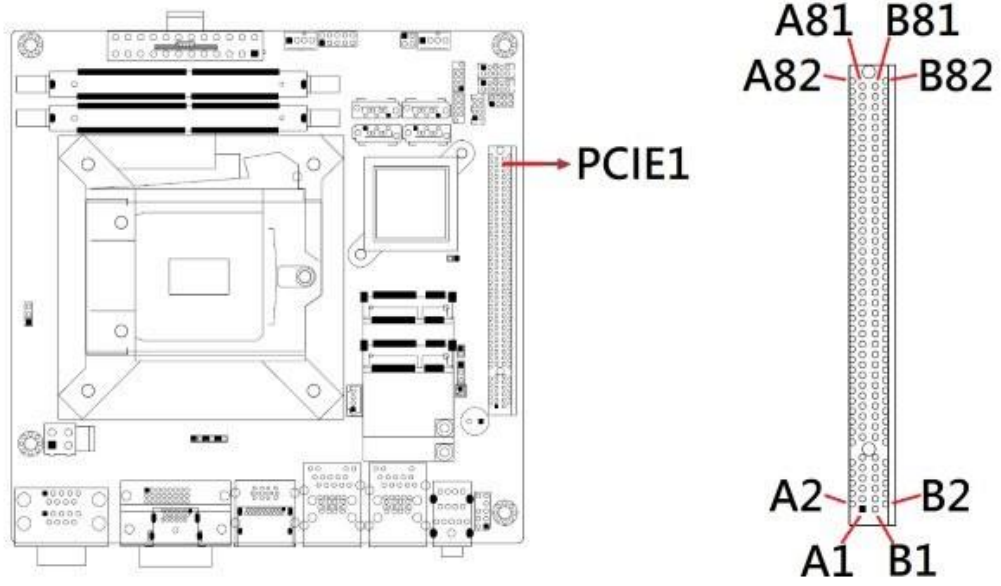

Note: 2EG08211-D2D-DF

Chapter 3

Driver Installation

The information provided in this chapter includes:

- Introduction
- Intel® Chipset Software Installation Utility
- VGA Drivers Installation
- Realtek HD Audio Driver Installation
- LAN Drivers Installation
- Intel® Management Engine Interface
- Intel® USB 3.0 Drivers

3.1 Introduction

This section describes the installation procedures for software drivers. The software drivers are available in the IBASE website.

Note: After installing your Windows operating system, you must install the Intel® Chipset Software Installation Utility first before proceeding with the drivers installation.

3.2 Intel® Chipset Software Installation Utility

The Intel® Chipset drivers should be installed first before the software drivers to install INF files for Plug & Play function for the chipset components. Follow the instructions below to complete the installation.

1. Visit the IBASE download page and navigate to your product's support section. Download the compressed driver package and copy it to your system. Double-click the file to extract its contents. Run the CDGuide to open the main driver interface. In the left navigation pane, click Intel, and then Intel(R) Skylake Chipset Drivers.



2. Click Intel(R) Chipset Software Installation Utility.



3. When the Welcome screen to the Intel® Chipset Device Software appears, click Next to continue.
4. Click Yes to accept the software license agreement and proceed with the installation process.
5. On the Readme File Information screen, click Install to continue the installation.
6. The Setup process is now complete. Click Finish to restart the computer and for changes to take effect.

3.3 VGA Drivers Installation

1. Click Intel and then Intel(R) Skylake Chipset Drivers.



2. Click Intel(R) HD Graphics Driver.



3. When the Welcome screen appears, click Next to continue.

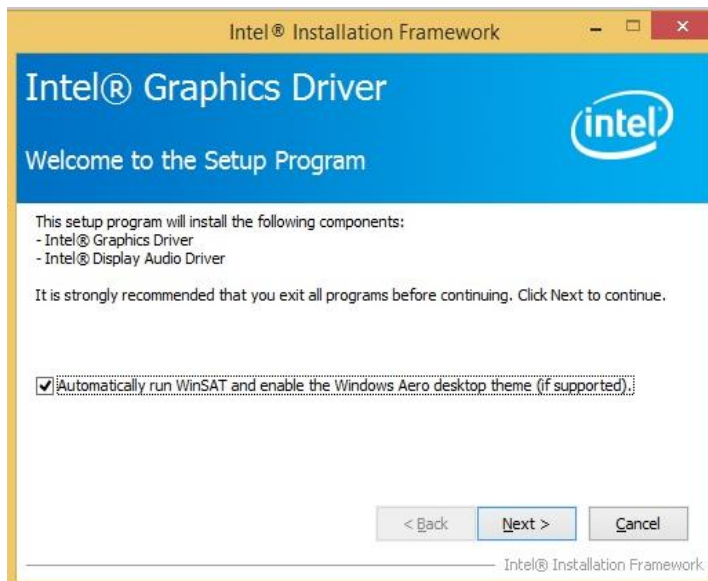

4. Click Yes to agree with the license agreement and continue the installation.
5. On the screen shown below, click Install to continue.



6. Setup complete. Click Finish to restart the computer and for changes to take effect.

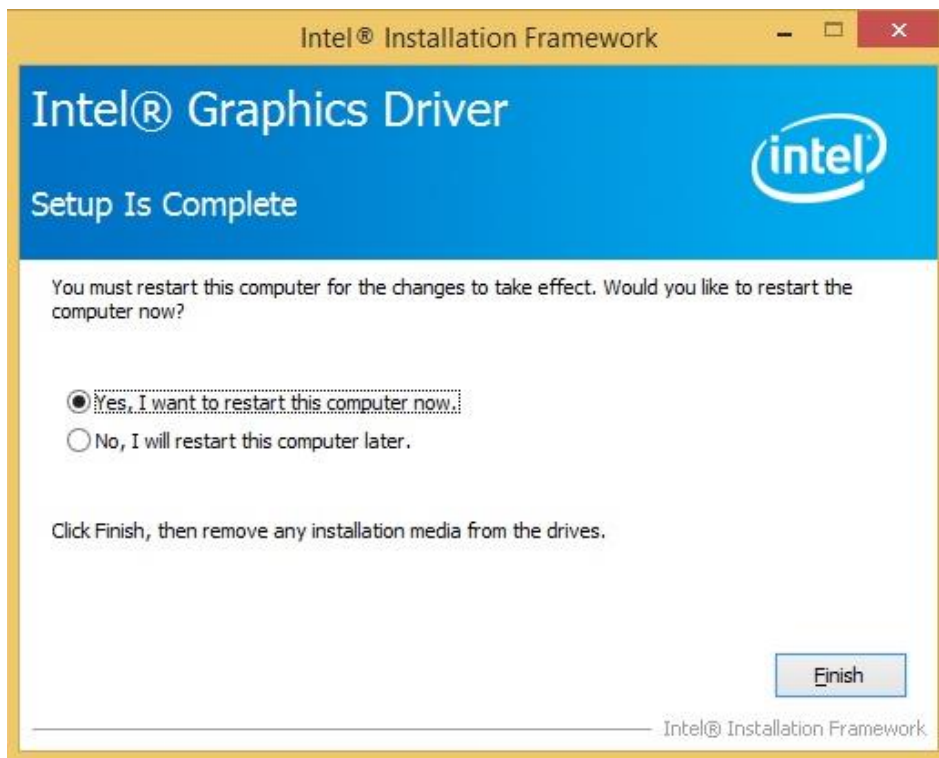

3.4 Realtek HD Audio Driver Installation

1. Click Intel and then Intel(R) Skylake Chipset Drivers.



2. Click Realtek High Definition Audio Driver.

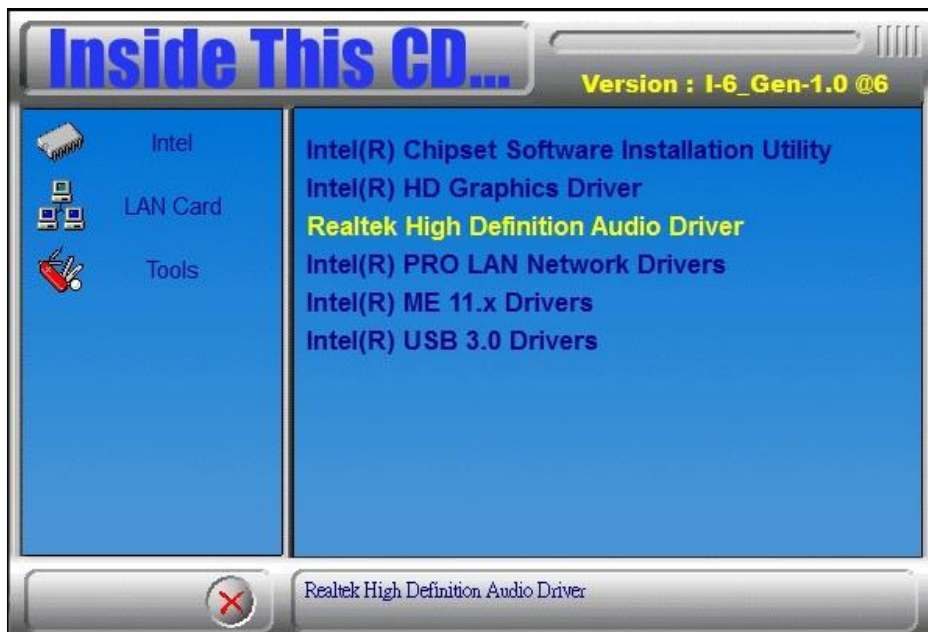

3. On the Welcome to the InstallShield Wizard screen, click Next to proceed with and complete the installation process.

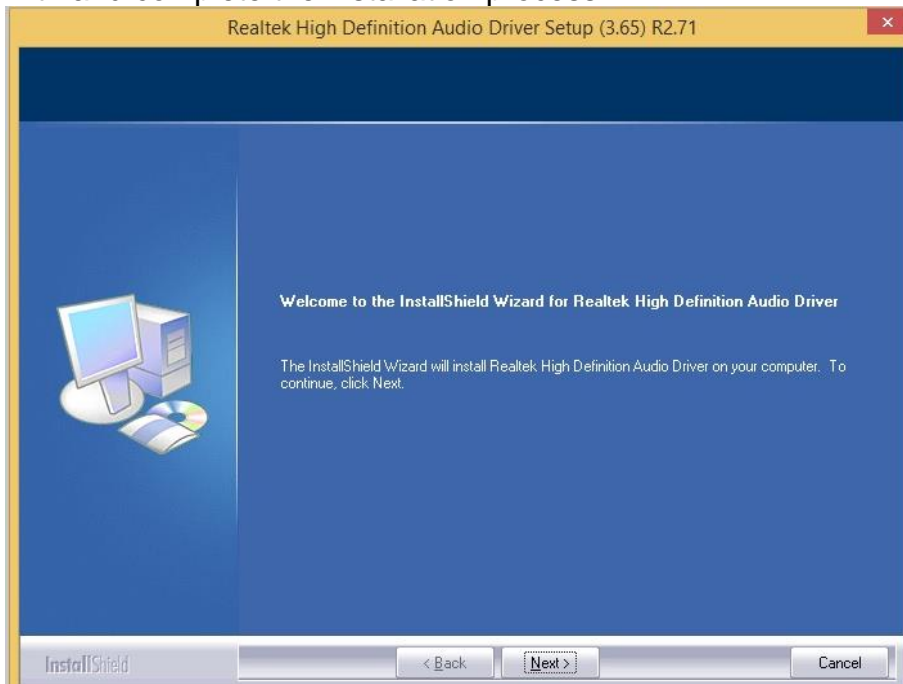

4. The InstallShield Wizard Complete. Click Finish to restart the computer and for changes to take effect.

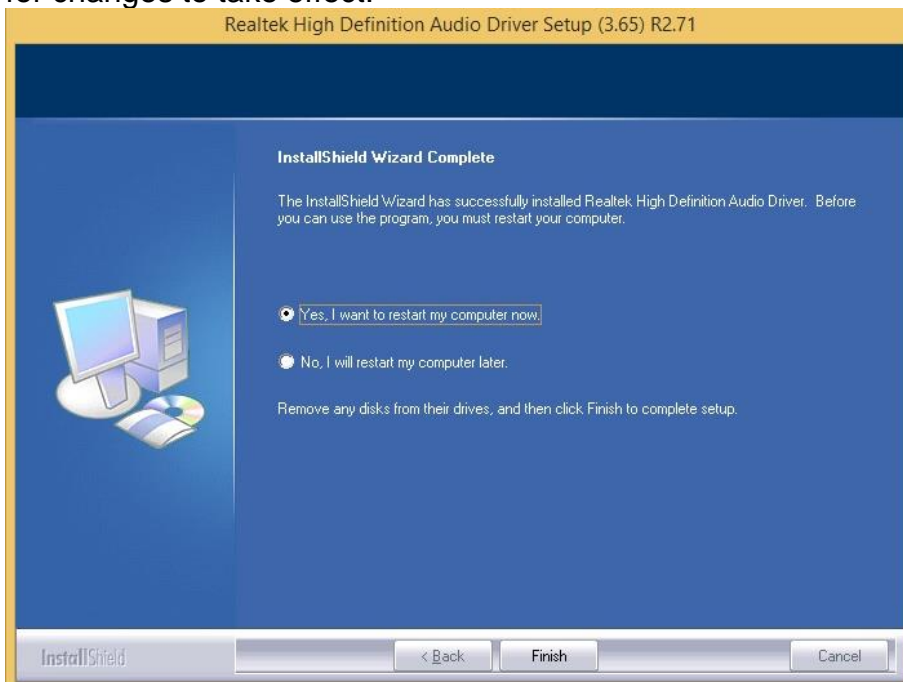

3.5 LAN Drivers Installation

1. Click Intel and then Intel(R) Skylake Chipset Drivers.

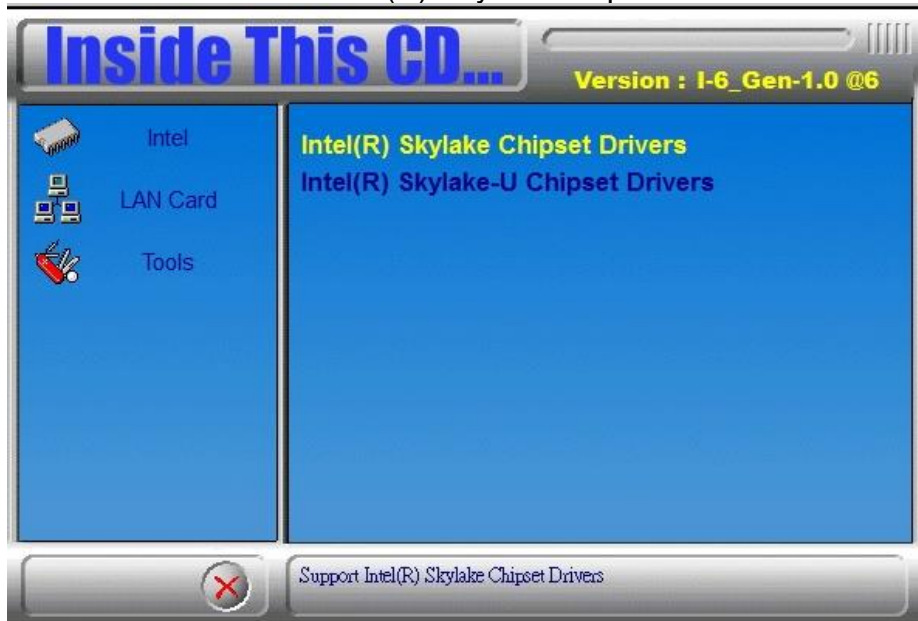

2. Click Intel(R) PRO LAN Network Driver.



3. Click Install Drivers and Software.

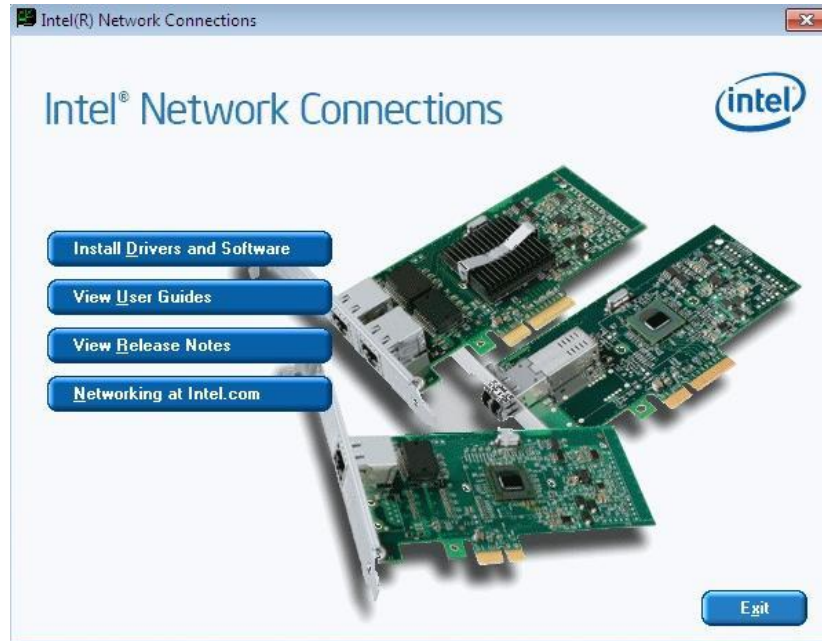

4. When the Welcome screen appears, click Next.

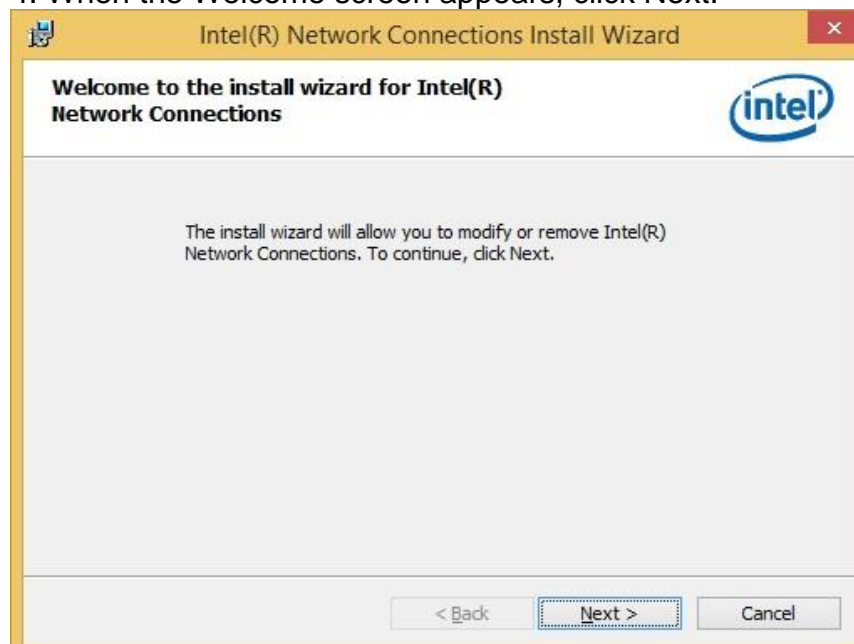

5. Click Next to to agree with the license agreement.

6. Click the checkbox for Drivers in the Setup Options screen to select it and click Next to continue.

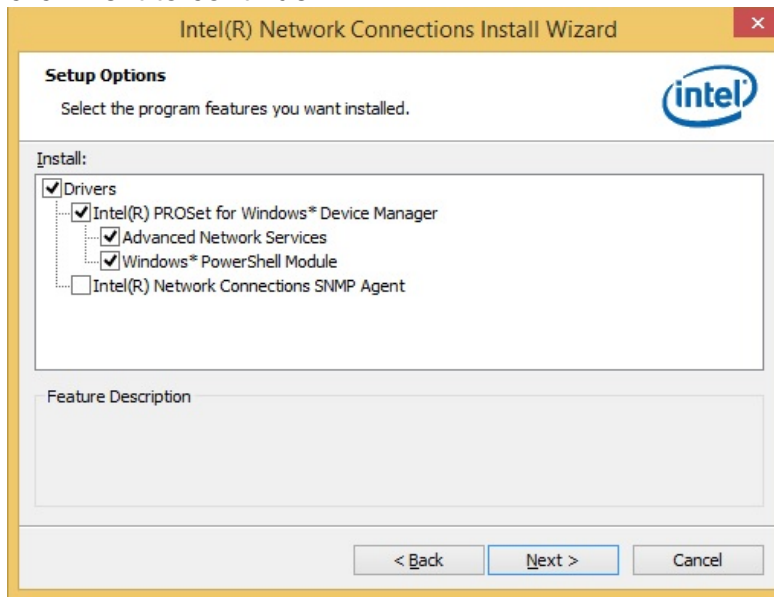

7. The wizard is ready to begin installation. Click Install to begin the installation.



8. When InstallShield Wizard is complete, click Finish.

3.6 Intel® Management Engine Interface

1. Click Intel and then Intel(R) Skylake Chipset Drivers.



2. When the Welcome screen to the InstallShield Wizard for Intel® Management Engine Components, click the checkbox for Install Intel® Control Center & click Next.

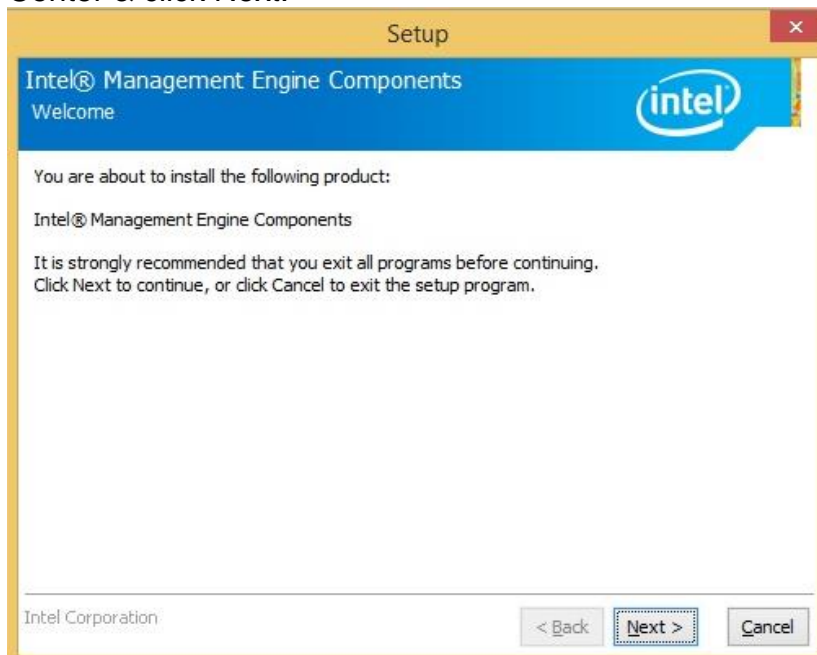

3. Click Next to agree with the license agreement.



4. When the Setup Progress screen appears, click Next. Then, click Finish when the setup progress has been successfully installed.

3.7 Intel® USB 3.0 Drivers

1. Click Intel and then Intel(R) Skylake Chipset Drivers.

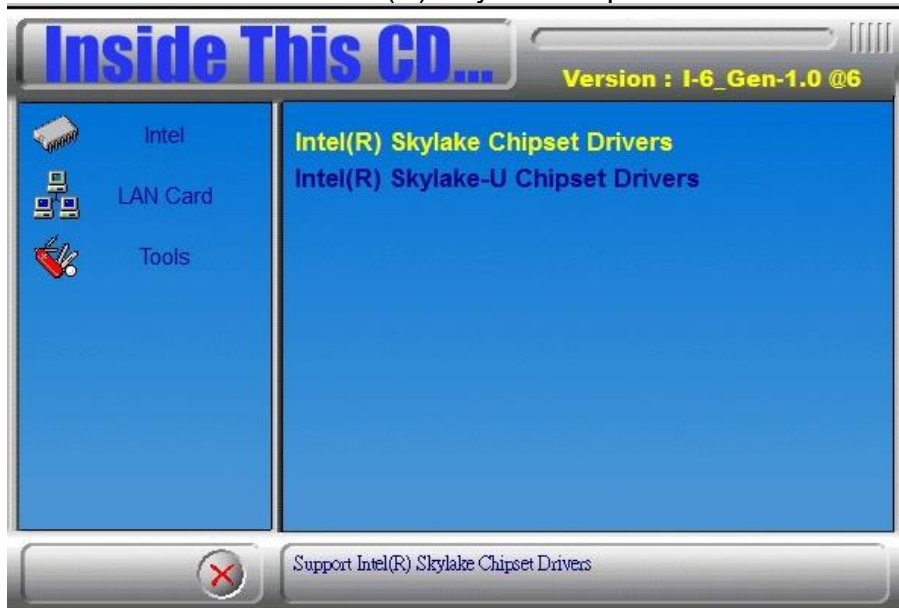

2. Click Intel(R) USB 3.0 Drivers.

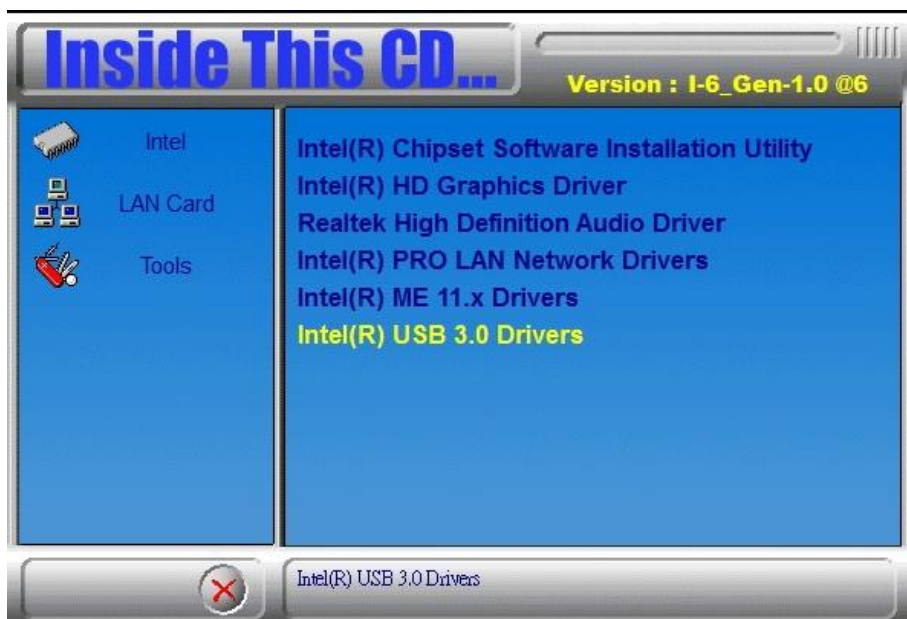

3. When the Welcome screen to the InstallShield Wizard for Intel® USB 3.0 eXtensible Host Controller Driver, click Next.

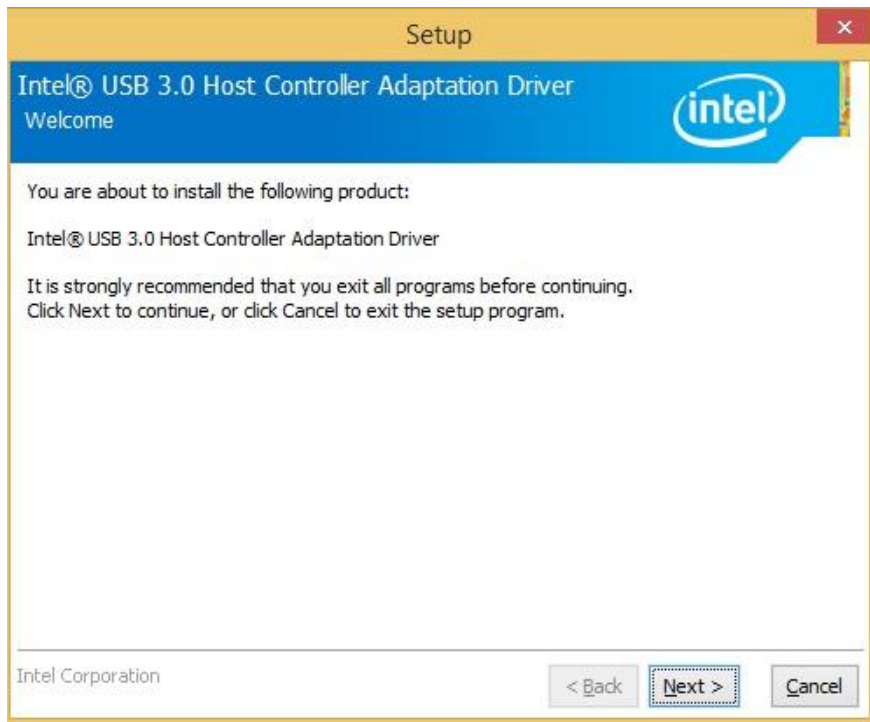

4. Click Next to agree with the license agreement and continue the installation.

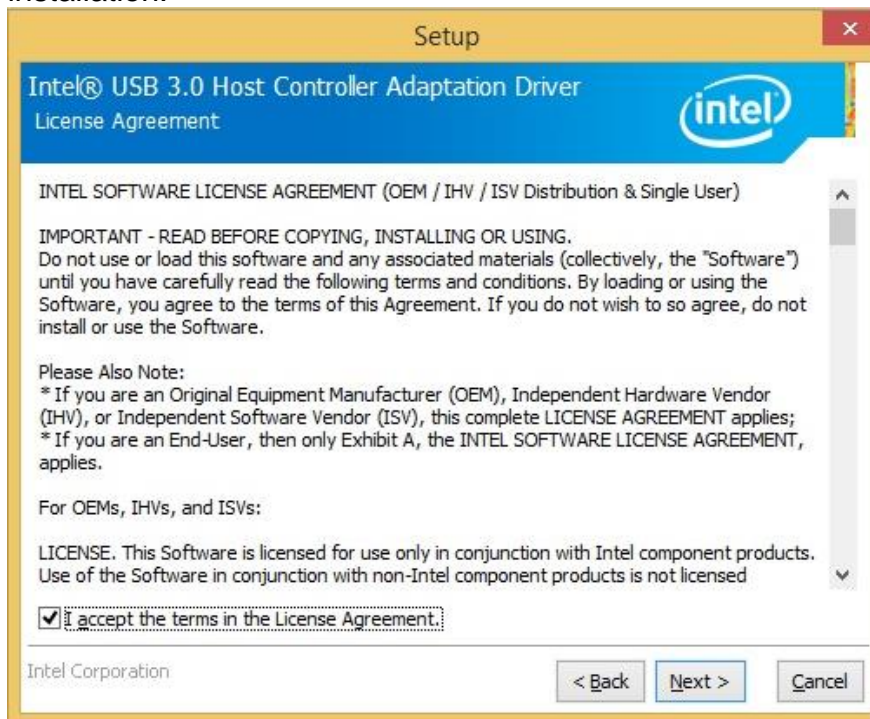

5. On the Readme File Information screen, click Next to continue the installation of the Intel® USB 3.0 eXtensible Host Controller Driver.

6. Setup complete. Click Finish to restart the computer and for changes to take effect.

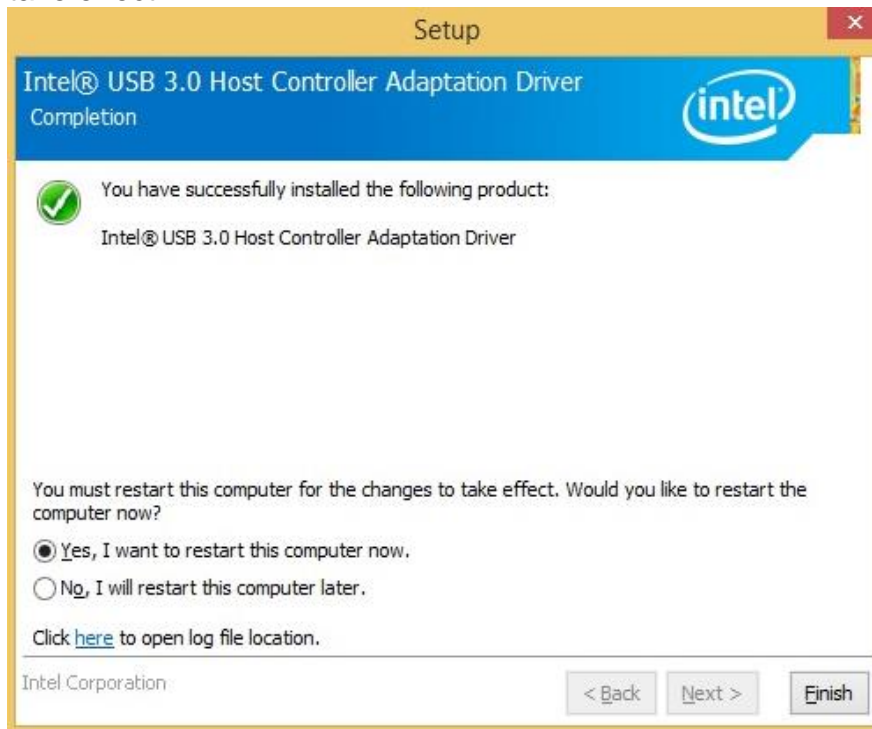

Chapter 4

BIOS Setup

This chapter describes the different settings available in the AMI BIOS that comes with the board. The topics covered in this chapter are as follows:

- Main Settings
- Advanced Settings
- Chipset Settings
- Security Settings
- Boot Settings
- Save & Exit

4.1 Introduction

The BIOS (Basic Input/Output System) installed in the ROM of your computer system supports Intel® processors. The BIOS provides critical low-level support for standard devices such as disk drives, and serial ports. It also provides password protection as well as special support for detailed fine-tuning of the chipset controlling the entire system.

4.2 BIOS Setup

The BIOS provides a Setup utility program for specifying the system configurations and settings. The BIOS ROM of the system stores the Setup utility. When you turn on the computer, the BIOS is immediately activated. Press the key immediately allows you to enter the Setup utility. If you are a little bit late pressing the key, POST (Power On Self Test) will continue with its test routines, thus preventing you from invoking the Setup.

If you still need to enter Setup, restart the system by pressing the "Reset" button or simultaneously pressing the <Ctrl>, <Alt> and <Delete> keys. You can also restart by turning the system Off and back On again.

The following message will appear on the screen:

```
Press <DEL> to Enter Setup
```

In general, press the arrow keys to highlight items, <Enter> to select, the <PgUp> and <PgDn> keys to change entries, <F1> for help, and <Esc> to quit.

When you enter the BIOS Setup utility, the *Main Menu* screen will appear on the screen. The Main Menu allows you to select from various setup functions and exit choices.

Warning: It is strongly recommended that you avoid making any changes to the chipset defaults.

These defaults have been carefully chosen by both AMI and your system manufacturer to provide the absolute maximum performance and reliability. Changing the defaults could make the system unstable and crash in some cases.

4.3 Main Settings

Aptio Setup Utility – Copyright © 2011 American Megatrends, Inc.

Main	Advanced	Chipset	Security	Boot	Save & Exit
Total Memory			4096 MB		Choose the system default language
Memory Frequency			2133 MHz		→ ← Select Screen
					↑ ↓ Select Item
					Enter: Select
System Date			[Tue 01/20/2009]		+ - Change Field
System Time			[21:52:06]		F1: General Help
					F2: Previous Values
					F3: Optimized Default
					F4: Save ESC: Exit

System Date

Set the Date. Use Tab to switch between Data elements.

System Time

Set the Time. Use Tab to switch between Data elements.

4.4 Advanced Settings

This section allows you to configure and improve your system and allows you to set up some system features according to your preference.

Aptio Setup Utility	
Main	Advanced
<ul style="list-style-type: none"> ▶ CPU Configuration ▶ Power & Performance ▶ PCH-FW Configuration ▶ Trusted Computing ▶ ACPI Settings ▶ iSmart Controller ▶ F81846 Super IO Configuration ▶ Hardware Monitor ▶ CSM Configuration ▶ USB Configuration 	<ul style="list-style-type: none"> → ← Select Screen ↑ ↓ Select Item Enter: Select + - Change Field F1: General Help F2: Previous Values F3: Optimized Default F4: Save ESC: Exit

CPU Configuration

This section shows the CPU configuration parameters.

Aptio Setup Utility – Copyright © 2012 American Megatrends, Inc.	
Main	Advanced
CPU Configuration	
Type	Intel(R) CPU Core(TM)i5-7500 @ 2.40GHz
ID	0x906E9
Speed	3400 MHz
VMX	Supported
SMX/TXT	Supported
Intel (VMX) Virtualization Technology	Enabled
Active Processor Cores	All
AES	Enabled
Intel Trusted Execution Technology	Disabled
	<ul style="list-style-type: none"> → ← Select Screen ↑ ↓ Select Item Enter: Select + - Change Field F1: General Help F2: Previous Values F3: Optimized Default F4: Save ESC: Exit

Intel (VMX) Virtualization Technology

When enabled, a VMM can utilize the additional hardware capabilities provided by Vanderpool Technology.

Active Processor Cores

Number of cores to enable in each processor package.

AES

Enable/Disable AES (Advanced Encryption Standard).

Power & Performance

Aptio Setup Utility					
Main	Advanced	Chipset	Security	Boot	Save & Exit
Power & Performance				→ ←	Select Screen
▶ CPU - Power Management Control				↑ ↓	Select Item
				Enter:	Select
				+ -	Change Field
				F1:	General Help
				F2:	Previous Values
				F3:	Optimized Default
				F4: Save	ESC: Exit

CPU - Power Management Control

Aptio Setup Utility					
Main	Advanced	Chipset	Security	Boot	Save & Exit
CPU - Power Management Control					
Intel(R) SpeedStep(tm)		Enabled		→ ←	Select Screen
Intel(R) Speed Shift Technology		Enabled		↑ ↓	Select Item
Turbo Mode		Enabled		Enter:	Select
				+ -	Change Field
				F1:	General Help
				F2:	Previous Values
				F3:	Optimized Default
				F4: Save	ESC: Exit

Intel(R) SpeedStep(tm)

Allows more than two frequency ranges to be supported.

Intel(R) Speed Shift Technology

Enable/Disable Intel(R) Speed Shift Technology Support. Enabling will expose the CPPC v2 interface to allow for hardware controlled P-states.

Turbo Mode

Enable/Disable processor Turbo Mode (requires EMTTM enabled too). Auto means enabled, unless max turbo ratio is bigger than 16 – SKL A0 W/A.

PCH-FW Configuration

Aptio Setup Utility					
Main	Advanced	Chipset	Security	Boot	Save & Exit
	ME Firmware Version	11.6.10.1196			
	ME Firmware Mode	Normal Mode		→ ←	Select Screen
	ME Firmware SKU	Corporate SKU		↑ ↓	Select Item
	ME File System Integrity Value	2		Enter:	Select
	ME Firmware Status 1	0x90000245		+ -	Change Field
	ME Firmware Status 2	0x80108306		F1:	General Help
				F2:	Previous Values
	AMT BIOS Features	Enabled		F3:	Optimized Default
				F4:	Save ESC: Exit

AMT BIOS Features

This configuration is supported only with MI991AF-C236 and MI991AF. When disabled AMT BIOS Features are no longer supported and user is no longer able to access MEBx setup.

Trusted Computing

Aptio Setup Utility					
Main	Advanced	Chipset	Security	Boot	Save & Exit
	Configuration				
	Security Device Support	Disabled		→ ←	Select Screen
	No Security Device Found	Disabled		↑ ↓	Select Item
				Enter:	Select
				+ -	Change Field
				F1:	General Help
				F2:	Previous Values
				F3:	Optimized Default
				F4:	Save ESC: Exit

Security Device Support

This configuration is supported only with MI991AF-C236 and MI991AF. Enables or Disables TPM support. O.S. will not show TPM. Reset of platform is required.

ACPI Settings

Aptio Setup Utility					
Main	Advanced	Chipset	Security	Boot	Save & Exit
ACPI Settings				→ ←	Select Screen
Enable Hibernation				↑ ↓	Select Item
ACPI Sleep State				Enter:	Select
S3 (Suspend to R...)				+ -	Change Field
				F1:	General Help
				F2:	Previous Values
				F3:	Optimized Default
				F4:	Save ESC: Exit

Enable Hibernation

Enables or Disables System ability to Hibernate (OS/S4 Sleep State). This option may be not effective with some OS.

ACPI Sleep State

Select ACPI sleep state the system will enter, when the SUSPEND button is pressed.

iSmart Controller

Aptio Setup Utility					
Main	Advanced	Chipset	Security	Boot	Save & Exit
iSmart Controller				→ ←	Select Screen
Power-On after Power failure				↑ ↓	Select Item
Temperature Guardian				Enter:	Select
Schedule Slot 1				+ -	Change Field
Schedule Slot 2				F1:	General Help
				F2:	Previous Values
				F3:	Optimized Default
				F4:	Save ESC: Exit

Power-On after Power failure

This field sets the system power status whether *Disable* or *Enable* when power returns to the system from a power failure situation.

Temperature Guardian

Generate the reset signal when system hangs up on POST

Schedule Slot 1 / 2

Setup the hour/minute for system power on.

F81846 Super IO Configuration

Aptio Setup Utility					
Main	Advanced	Chipset	Security	Boot	Save & Exit
F81846 Super IO Configuration					
Super IO Chip		F81866		→ ←	Select Screen
Standby Power on S5(Eup)		All Enable		↑ ↓	Select Item
▶ Serial Port 1 Configuration				Enter:	Select
▶ Serial Port 2 Configuration				+ -	Change Field
▶ Serial Port 3 Configuration				F1:	General Help
▶ Serial Port 4 Configuration				F2:	Previous Values
				F3:	Optimized Default
				F4:	Save ESC: Exit

Standby Power on S5(Eup)

This configuration is supported only with MI991EF.

Serial Port Configuration

Set Parameters of Serial Ports. User can Enable/Disable the serial port and Select an optimal settings for the Super IO Device.

Hardware Monitor

Aptio Setup Utility					
Main	Advanced	Chipset	Security	Boot	Save & Exit
PC Health Status					
CPU smart fan control		Disabled			
System smart fan control		Disabled			
CPU temperature		+33 C			
System temperature		+34 C			
CPU FAN Speed		2170 RPM			
SYS FAN Speed		N/A			
VCORE		+1.112 V		→ ← Select Screen	
+5V		+5.087 V		↑ ↓ Select Item	
+12V		+12.408 V		Enter: Select	
Memory Voltage		+1.560 V		+- Change Field	
+3.3V		+3.376V		F1: General Help	
				F2: Previous Values	
				F3: Optimized Default	
				F4: Save ESC: Exit	
CPU Shutdown Temperature		Disabled			

CPU/System smart fan control

This field enables or disables the smart fan feature.
 Disabled (default)

- 50 °C
- 60 °C
- 70 °C
- 80 °C
- 90 °C

Temperatures/Voltages

These fields are the parameters of the hardware monitoring function feature of the motherboard. The values are read-only values as monitored by the system and show the PC health status.

CPU Shutdown Temperature

The default setting is Disabled.

CSM Configuration

Aptio Setup Utility					
Main	Advanced	Chipset	Security	Boot	Save & Exit
Option ROM execution					
Network		Do not launch		→ ← Select Screen ↑ ↓ Select Item Enter: Select +- Change Field F1: General Help F2: Previous Values F3: Optimized Default F4: Save ESC: Exit	

Network

Controls the execution of UEFI and Legacy PXE OpROM

USB Configuration

Aptio Setup Utility - Copyright © 2012 American Megatrends, Inc.

Main	Advanced	Chipset	Boot	Security	Save & Exit
USB Configuration					
USB Module Version		17			
USB Controllers:					
1 XHCI					
USB Devices:					
1 Keyboard					
Legacy USB Support		Enabled			
XHCI Hand-off		Enabled			
USB Mass Storage Driver Support		Enabled			
Port 60/64 Emulation		Disabled			
USB hardware delays and time-outs:					
USB Transfer time-out		20 sec			
Device reset time-out		20 sec			
Device power-up delay		Auto			
→ ← Select Screen ↑ ↓ Select Item Enter: Select +- Change Opt. F1: General Help F2: Previous Values F3: Optimized Defaults F4: Save & Exit ESC: Exit					

Legacy USB Support

Enables Legacy USB support.

AUTO option disables legacy support if no USB devices are connected.

DISABLE option will keep USB devices available only for EFI applications.

XHCI Hand-off

This is a workaround for OSes without XHCI hand-off support. The XHCI ownership change should be claimed by XHCI driver.

USB Mass Storage Driver Support

Enable/Disable USB Mass Storage Driver Support.

Port 60/64 Emulation

Enables I/O port 60h/64h emulation support. This should be enabled for the complete USB keyboard legacy support for non-USB aware OSes.

USB Transfer time-out

The time-out value for Control, Bulk, and Interrupt transfers.

Device reset time-out

USB mass Storage device start Unit command time-out.

Device power-up delay

Maximum time the device will take before it properly reports itself to the Host Controller. 'Auto' uses default value: for a Root port it is 100ms, for a Hub port the delay is taken from Hub descriptor.

EHCI Hand-off

Enabled/Disabled. This is a workaround for OSes without EHCI hand-off support. The EHCI ownership change should be claimed by EHCI driver.

USB Mass Storage Driver Support

Enable/Disable USB Mass Storage Driver Support.

USB Transfer time-out

The time-out value for Control, Bulk, and Interrupt transfers.

Device reset time-out

USB mass Storage device start Unit command time-out.

Device power-up delay

Maximum time the device will take before it properly reports itself to the Host Controller. 'Auto' uses default value: for a Root port it is 100ms, for a Hub port the delay is taken from Hub descriptor.

4.5 Chipset Settings

This section allows you to configure and improve your system and allows you to set up some system features according to your preference.

Aptio Setup Utility					
Main	Advanced	Chipset	Security	Boot	Save & Exit
<ul style="list-style-type: none"> ▶ System Agent (SA) Configuration ▶ PCH-IO Configuration 			<ul style="list-style-type: none"> → ← Select Screen ↑ ↓ Select Item Enter: Select + - Change Field F1: General Help F2: Previous Values F3: Optimized Default F4: Save ESC: Exit 		

System Agent (SA) Configuration

Aptio Setup Utility					
Main	Advanced	Chipset	Security	Boot	Save & Exit
System Agent (SA) Configuration			<ul style="list-style-type: none"> → ← Select Screen ↑ ↓ Select Item Enter: Select + - Change Field F1: General Help F2: Previous Values F3: Optimized Default F4: Save ESC: Exit 		
SA PCIe Code Version		1.5.0.0			
VT-d		Supported			
▶ Graphics Configuration					
VT-d		Enabled			

VT-d

Check to enable VT-d function on MCH.

Graphics Configuration

Aptio Setup Utility					
Main	Advanced	Chipset	Security	Boot	Save & Exit
Graphics Configuration					
Skip Scanning of External Gfx Card		Disabled			
Primary Display		Auto		→ ← Select Screen	
Select PCIE Card		Auto		↑ ↓ Select Item	
▶ External Gfx Card Primary Display Configuration				Enter: Select	
Internal Graphics		Auto		+- Change Field	
GTT Size		8MB		F1: General Help	
Aperture Size		256MB		F2: Previous Values	
DVMT Pre-Allocated		32M		F3: Optimized Default	
DVMT Total Gfx Mem		256MB		F4: Save ESC: Exit	
Gfx Low Power Mode		Disabled			

Skip Scanning of External Gfx Card

If Enable, it will not scan for External Gfx Card on PEG and PCH PCIE ports.

Primary Display

Select which of IGFX/PEG/PCI graphics device should be primary display or select SG for switchable Gfx.

Select PCIE Card

Select the card used on the platform.

Auto : Skip GPIO based Power Enable to dGPU.

Elk Creek 4 : DGPU Power Enable = ActiveLow.

PEG Eval : DGPU Power Enable = ActiveHigh.

Internal Graphics

Keep IGD enabled based on the setup options.

DVMT Pre-Allocated

Select DVMT 5.0 Pre-Allocated (Fixed) graphics memory size used by the internal graphics device.

DVMT Total Gfx Mem

Select DVMT 5.0 total graphics memory size used by the internal graphics device.

Gfx Low Power Mode

This option is applicable for SFF only.

External Gfx Card Primary Display Configuration

Aptio Setup Utility					
Main	Advanced	Chipset	Security	Boot	Save & Exit
External Gfx Card Primary Display Configuration					
Primary PEG		Auto		→ ← Select Screen ↑ ↓ Select Item Enter: Select +- Change Field F1: General Help F2: Previous Values F3: Optimized Default F4: Save ESC: Exit	
Primary PCIE		Auto			

Primary PEG

Select PEGO/PEG1/PEG2/PEG3 Graphics device should be Primary PEG.

Primary PCIE

Select PCIE0/PCIE1/PCIE2/PCIE3/PCIE4/PCIE5/PCIE6/PCIE7 Graphics device should be primary PCIE.

PCH-IO Configuration

This section allows you to configure the North Bridge Chipset.

Aptio Setup Utility					
Main	Advanced	Chipset	Security	Boot	Save & Exit
PCH-IO Configuration					
▶ SATA And RST Configuration					
PCH LAN Controller		Enabled		→ ← Select Screen ↑ ↓ Select Item Enter: Select +- Change Field F1: General Help F2: Previous Values F3: Optimized Default F4: Save ESC: Exit	
Wake on LAN Enable		Enabled			

PCH LAN Controller

Enable or disable onboard NIC.

Wake on LAN

Enable or disable integrated LAN to wake the system. (The Wake On LAN cannot be disabled if ME is on at Sx state.)

SATA And RST Configuration

SATA Devices Configuration.

Aptio Setup Utility - Copyright © 2012 American Megatrends, Inc.

Main	Advanced	Chipset	Security	Boot	Save & Exit
	SATA Controller(s)	Enabled			
	SATA Mode Selection	AHCI			
	SATA Port0	Empty			
	Software Preserve	Unknown			
	Hot Plug	Disabled			
	SATA Port1	Empty			
	Software Preserve	Unknown			
	Hot Plug	Disabled			
	SATA Port2	Empty			
	Software Preserve	Unknown			
	Hot Plug	Disabled			
	SATA Port3	Empty			
	Software Preserve	Unknown			
	Hot Plug	Disabled			
	SATA Port4	Empty			
	Software Preserve	Unknown			
	Hot Plug	Disabled			

→ ← Select Screen
 ↑ ↓ Select Item
 Enter: Select
 +- Change Opt.
 F1: General Help
 F2: Previous Values
 F3: Optimized Defaults
 F4: Save & Exit
 ESC: Exit

SATA Controller(s)

Enable or disable SATA Device.

SATA Mode Selection

Determines how SATA controller(s) operate.

- (1) AHCI Mode.
- (2) RAID Mode.

Hot Plug

Designates this port as Hot Pluggable.

4.6 Security Settings

This section allows you to configure and improve your system and allows you to set up some system features according to your preference.

Aptio Setup Utility				
Main	Advanced	Chipset	Security	Boot Save & Exit
Password Description If ONLY the Administrator's password is set, then this only limit access to Setup and is only asked for when entering Setup. If ONLY the User's password is set, then this is a power on password and must be entered to boot or enter Setup. In Setup the User will have Administrator rights The password length must be in the following range: Minimum length 3 Maximum length 20 Administrator Password User Password			→ ← Select Screen ↑ ↓ Select Item Enter: Select +- Change Field F1: General Help F2: Previous Values F3: Optimized Default F4: Save ESC: Exit	

Administrator Password

Set Setup Administrator Password.

User Password

Set User Password.

4.7 Boot Settings

This section allows you to configure the boot settings.

Aptio Setup Utility					
Main	Advanced	Chipset	Security	Boot	Save & Exit
Boot Configuration					
Setup Prompt Timeout		1			
Bootup NumLock State		Off			
Quiet Boot		Disabled			
Fast Boot		Disabled			
Boot mode Select		LEGACY			
FIXED BOOT ORDER Priorities					
Boot Option #1		Hard Disk		→ ←	Select Screen
Boot Option #2		CD/DVD		↑ ↓	Select Item
Boot Option #3		USB Hard Disk		Enter:	Select
Boot Option #4		USB CD/DVD		+ -	Change Field
Boot Option #5		USB Key		F1:	General Help
Boot Option #6		USB Floppy		F2:	Previous Values
Boot Option #7		USB Lan		F3:	Optimized Default
Boot Option #8		Network		F4:	Save ESC: Exit

Setup Prompt Timeout

Number of seconds to wait for setup activation key.
65535(0xFFFF) means indefinite waiting.

Bootup NumLock State

Select the keyboard NumLock state.

Quiet Boot

Enables/Disables Quiet Boot option.

Fast Boot

Enables/Disables boot with initialization of a minimal set of devices required to launch active boot option. Has no effect for BBS boot options.

FIXED BOOT ORDER Priorities

Sets the system boot order.

4.8 Save & Exit Settings

Aptio Setup Utility					
Main	Advanced	Chipset	Security	Boot	Save & Exit
Save Options					
Save Changes and Exit					
Discard Changes and Exit					
Save Changes and Reset					
Discard Changes and Reset					
Save Changes					
Discard Changes					
Defaults Options					
Restore Defaults					
Save as User Defaults					
Restore User Defaults					
					→ ← Select Screen ↑ ↓ Select Item Enter: Select +- Change Field F1: General Help F2: Previous Values F3: Optimized Default F4: Save ESC: Exit

Save Changes and Exit

Exit system setup after saving the changes.

Discard Changes and Exit

Exit system setup without saving any changes.

Save Changes and Reset

Reset the system after saving the changes.

Discard Changes and Reset

Reset system setup without saving any changes.

Save Changes

Save Changes done so far to any of the setup options.

Discard Changes

Discard Changes done so far to any of the setup options.

Restore Defaults

Restore/Load Defaults values for all the setup options.

Save as User Defaults

Save the changes done so far as User Defaults.

Restore User Defaults

Restore the User Defaults to all the setup options.

Appendix

This section provides the mapping addresses of peripheral devices and the sample code of watchdog timer configuration.

- I/O Port Address Map
- Watchdog Timer Configuration

A. I/O Port Address Map

Each peripheral device in the system is assigned a set of I/O port addresses which also becomes the identity of the device. The following table lists the I/O port addresses used.

Address	Device Description
0000h-0CF7h	PCI Express Root Complex
0040h-0043h	System timer
0050h-0053h	System timer
0070h-0070h	System CMOS/real time clock
00F0h-00F0h	Numeric data processor
02E8h-02EFh	Communications Port (COM4)
02F8h-02FFh	Communications Port (COM2)
03B0h-03BBh	Intel(R) HD Graphics 530
03C0h-03DFh	Intel(R) HD Graphics 530
03E8h-03EFh	Communications Port (COM3)
03F8h-03FFh	Communications Port (COM1)
0D00h-FFFFh	PCI Express Root Complex
E000h-0E01h	Intel(R) 100 Series/C230 Series Chipset Family PCI Express Root Port #6 - A115
F000h-F03Fh	Intel(R) HD Graphics 530
F040h-F05Fh	Intel(R) 100 Series/C230 Series Chipset SMBus - A123
F060h-F07Fh	Standard SATA AHCI Controller
F080h-F083h	Standard SATA AHCI Controller
F090h-F097h	Standard SATA AHCI Controller
F0A0h-F0A7h	Intel(R) Active Management Technology - SOL (COM5)

B. Watchdog Timer Configuration

The WDT is used to generate a variety of output signals after a user programmable count. The WDT is suitable for use in the prevention of system lock-up, such as when software becomes trapped in a deadlock. Under these sorts of circumstances, the timer will count to zero and the selected outputs will be driven. Under normal circumstance, the user will restart the WDT at regular intervals before the timer counts to zero.

SAMPLE CODE:

```
//-----
//
// THIS CODE AND INFORMATION IS PROVIDED "AS IS" WITHOUT WARRANTY OF ANY
// KIND, EITHER EXPRESSED OR IMPLIED, INCLUDING BUT NOT LIMITED TO THE
// IMPLIED WARRANTIES OF MERCHANTABILITY AND/OR FITNESS FOR A
// PARTICULAR
// PURPOSE.
//
//-----
#include <dos.h>
#include <conio.h>
#include <stdio.h>
#include <stdlib.h>
#include "F81866.H"
//-----
int main (int argc, char *argv[]);
void EnableWDT(int);
void DisableWDT(void);
//-----
int main (int argc, char *argv[])
{
    unsigned char bBuf;
    unsigned char bTime;
    char *endptr = NULL;
    char SIO;

    printf("Fintek 81866 watch dog program\n");

    SIO = Init_F81866();
    if (SIO == 0)
    {
        printf("Can not detect Fintek 81866, program abort.\n");
        return(1);
    }/if (SIO == 0)

    if (argc != 2)
    {
        printf(" Parameter incorrect!!\n");
        return (1);
    }

    bTime = (unsigned char)strtol(argv[1], &endptr, 10);
    printf("System will reset after %d seconds\n", bTime);
```

iBASE

```
    if (bTime)
    {    EnableWDT(bTime); }
    else
    {    DisableWDT(); }

    return 0;
}
//-----
void EnableWDT(int interval)
{
    unsigned char bBuf;

    bBuf = Get_F81866_Reg(0x2B);
    bBuf &= (~0x20);
    Set_F81866_Reg(0x2B, bBuf);                //Enable WDTO

    Set_F81866_LD(0x07);                      //switch to logic device 7
    Set_F81866_Reg(0x30, 0x01);              //enable timer

    bBuf = Get_F81866_Reg(0xF5);
    bBuf &= (~0x0F);
    bBuf |= 0x52;
    Set_F81866_Reg(0xF5, bBuf);              //count mode is second

    Set_F81866_Reg(0xF6, interval);          //set timer

    bBuf = Get_F81866_Reg(0xFA);
    bBuf |= 0x01;
    Set_F81866_Reg(0xFA, bBuf);              //enable WDTO output

    bBuf = Get_F81866_Reg(0xF5);
    bBuf |= 0x20;
    Set_F81866_Reg(0xF5, bBuf);              //start counting
}
//-----
void DisableWDT(void)
{
    unsigned char bBuf;

    Set_F81866_LD(0x07);                    //switch to logic device 7

    bBuf = Get_F81866_Reg(0xFA);
    bBuf &= ~0x01;
    Set_F81866_Reg(0xFA, bBuf);              //disable WDTO output

    bBuf = Get_F81866_Reg(0xF5);
    bBuf &= ~0x20;
    bBuf |= 0x40;
    Set_F81866_Reg(0xF5, bBuf);              //disable WDT
}
//-----
```

```

//-----
//
// THIS CODE AND INFORMATION IS PROVIDED "AS IS" WITHOUT WARRANTY OF ANY
// KIND, EITHER EXPRESSED OR IMPLIED, INCLUDING BUT NOT LIMITED TO THE
// IMPLIED WARRANTIES OF MERCHANTABILITY AND/OR FITNESS FOR A
// PARTICULAR
// PURPOSE.
//
//-----
#include "F81866.H"
#include <dos.h>
//-----
unsigned int F81866_BASE;
void Unlock_F81866 (void);
void Lock_F81866 (void);
//-----
unsigned int Init_F81866(void)
{
    unsigned int result;
    unsigned char ucDid;

    F81866_BASE = 0x4E;
    result = F81866_BASE;

    ucDid = Get_F81866_Reg(0x20);
    if (ucDid == 0x07)                //Fintek 81866
    {   goto Init_Finish; }

    F81866_BASE = 0x2E;
    result = F81866_BASE;

    ucDid = Get_F81866_Reg(0x20);
    if (ucDid == 0x07)                //Fintek 81866
    {   goto Init_Finish; }

    F81866_BASE = 0x00;
    result = F81866_BASE;

Init_Finish:
    return (result);
}
//-----
void Unlock_F81866 (void)
{
    outportb(F81866_INDEX_PORT, F81866_UNLOCK);
    outportb(F81866_INDEX_PORT, F81866_UNLOCK);
}
//-----
void Lock_F81866 (void)
{
    outportb(F81866_INDEX_PORT, F81866_LOCK);
}
//-----
void Set_F81866_LD( unsigned char LD)

```

```
{
    Unlock_F81866();
    outportb(F81866_INDEX_PORT, F81866_REG_LD);
    outportb(F81866_DATA_PORT, LD);
    Lock_F81866();
}
//-----
void Set_F81866_Reg( unsigned char REG, unsigned char DATA)
{
    Unlock_F81866();
    outportb(F81866_INDEX_PORT, REG);
    outportb(F81866_DATA_PORT, DATA);
    Lock_F81866();
}
//-----

unsigned char Get_F81866_Reg(unsigned char REG)
{
    unsigned char Result;
    Unlock_F81866();
    outportb(F81866_INDEX_PORT, REG);
    Result = inportb(F81866_DATA_PORT);
    Lock_F81866();
    return Result;
}
//-----
```