

ASB200-916
Fanless System with
3.5" Disk-Size SBC System

User's Manual

Version 1.0a
(Oct. 2019)



Copyright

© 2018 IBASE Technology, Inc. All rights reserved.

No part of this publication may be reproduced, copied, stored in a retrieval system, translated into any language or transmitted in any form or by any means, electronic, mechanical, photocopying, or otherwise, without the prior written consent of IBASE Technology, Inc. (hereinafter referred to as "IBASE").

Disclaimer

IBASE reserves the right to make changes and improvements to the products described in this document without prior notice. Every effort has been made to ensure the information in the document is correct; however, IBASE does not guarantee this document is error-free. IBASE assumes no liability for incidental or consequential damages arising from misapplication or inability to use the product or the information contained herein, nor for any infringements of rights of third parties, which may result from its use.

Trademarks

All the trademarks, registrations and brands mentioned herein are used for identification purposes only and may be trademarks and/or registered trademarks of their respective owners.

Compliance

CE

This product has passed CE tests for environmental specifications and limits. This product is in accordance with the directives of the Union European (EU). If users modify and/or install other devices in this equipment, the CE conformity declaration may no longer apply.

FCC

This product has been tested and found to comply with the limits for a Class B device, pursuant to Part 15 of the FCC Rules. These limits are designed to provide reasonable protection against harmful interference in a residential installation. This equipment generates, uses and can radiate radio frequency energy and, if not installed and used in accordance with manufacturer's instructions, may cause harmful interference to radio communications.

WEEE



This product must not be disposed of as normal household waste, in accordance with the EU directive of for waste electrical and electronic equipment (WEEE - 2012/19/EU). Instead, it should be disposed of by returning it to a municipal recycling collection point. Check local regulations for disposal of electronic products.

Green IBASE



This product is compliant with the current RoHS restrictions and prohibits use of the following substances in concentrations exceeding 0.1% by weight (1000 ppm) except for cadmium, limited to 0.01% by weight (100 ppm).

- Lead (Pb)
- Mercury (Hg)
- Cadmium (Cd)
- Hexavalent chromium (Cr6+)
- Polybrominated biphenyls (PBB)
- Polybrominated diphenyl ether (PBDE)

Important Safety Information

Carefully read the precautions before using the device.

Environmental conditions:

- Lay the device horizontally on a stable and solid surface in case the device may fall, causing serious damage.
- Leave plenty of space around the device and do not block the openings for ventilation. **NEVER DROP OR INSERT ANY OBJECTS OF ANY KIND INTO THE VENTILATION OPENINGS.**
- Slots and openings on the chassis are for ventilation. Do not block or cover these openings. Make sure you leave plenty of space around the device for ventilation. **NEVER INSERT OBJECTS OF ANY KIND INTO THE VENTILATION OPENINGS.**
- Use this product in environments with ambient temperatures $-20^{\circ}\text{C} \sim 60^{\circ}\text{C}$ for SSD, and $0^{\circ}\text{C} \sim 45^{\circ}\text{C}$ for HDD.
- **DO NOT LEAVE THIS DEVICE IN AN ENVIRONMENT WHERE THE STORAGE TEMPERATURE MAY GO BELOW -20°C OR ABOVE 80°C .** This could damage the device. The device must be used in a controlled environment.

Care for your iBASE products:

- Before cleaning the device, turn it off and unplug all cables such as power in case a small amount of electrical current may still flow.
- Use neutral cleaning agents or diluted alcohol to clean the device chassis with a cloth. Then wipe the chassis with a dry cloth.
- Vacuum the dust with a computer vacuum cleaner to prevent the air vent or slots from being clogged.



WARNING

Attention during use:

- Do not use this product near water.
- Do not spill water or any other liquids on your device.
- Do not place heavy objects on the top of the device.
- Operate this device from the type of power indicated on the marking label. If you are not sure of the type of power available, consult your distributor or local power company.
- Do not walk on the power cord or allow anything to rest on it.
- If you use an extension cord, make sure that the total ampere rating of the product plugged into the extension cord does not exceed its limits.

Avoid Disassembly

Do not disassemble, repair or make any modification to the device. Disassembly, modification, or any attempt at repair could generate hazards and cause damage to the device, even bodily injury or property damage, and will void any warranty.



CAUTION

Danger of explosion if internal lithium-ion battery is replaced by an incorrect type. Replace only with the same or equivalent type recommended by the manufacturer. Dispose of used batteries according to the manufacturer's instructions.

Warranty Policy

- **IBASE standard products:**

24-month (2-year) warranty from the date of shipment. If the date of shipment cannot be ascertained, the product serial numbers can be used to determine the approximate shipping date.
- **3rd-party parts:**

12-month (1-year) warranty from delivery for the 3rd-party parts that are not manufactured by IBASE, such as CPU, memory, HDD, power adapter, panel and touchscreen.
- * PRODUCTS, HOWEVER, THAT FAILS DUE TO MISUSE, ACCIDENT, IMPROPER INSTALLATION OR UNAUTHORIZED REPAIR SHALL BE TREATED AS OUT OF WARRANTY AND CUSTOMERS SHALL BE BILLED FOR REPAIR AND SHIPPING CHARGES.

Technical Support & Services

1. Visit the IBASE website at www.ibase.com.tw to find the latest information about the product.
2. If you need any further assistance from your distributor or sales representative, prepare the following information of your product and elaborate upon the problem.
 - Product model name
 - Product serial number
 - Detailed description of the problem
 - The error messages in text or in screenshots if there is any
 - The arrangement of the peripherals
 - Software in use (such as OS and application software, including the version numbers)
3. If repair service is required, please log in to the RMA system of the website or contact your distributor or sales representative for assistance.

Table of Contents

Compliance.....	iii
Important Safety Information	iv
WARNING	iv
CAUTION	v
Warranty Policy.....	v
Technical Support & Services	v
Chapter 1 General Information.....	1
1.1 Introduction	2
1.2 Features.....	2
1.3 Packing List	3
1.4 Optional Accessories	3
1.5 Specifications.....	4
1.6 Overview.....	6
1.7 Dimensions	8
Chapter 2 Hardware Configuration.....	9
2.1 Installations.....	10
2.1.1 HDD Installation.....	10
2.1.2 Memory Installation	11
2.1.3 Mini-PCIe Card Installation	11
2.1.4 WiFi / 3G / 4G Antenna Installation.....	12
2.1.5 Wall Mounting Installation.....	12
2.1.6 VESA Mount Installation	13
2.1.7 Pinout for COM Ports, DC Power & Digital I/O Connectors.....	15
2.2 Setting the Jumpers	17
2.2.1 How to Set Jumpers	17
2.3 Jumper & Connector Locations on Motherboard	18
2.4 Jumpers Quick Reference.....	19
2.4.1 Clearing CMOS Data (JP2).....	19
2.4.2 Clearing ME Register (JP3).....	20
2.4.3 eDP Panel Power Selection (JP4).....	20
2.5 Connectors Quick Reference	21
2.5.1 eDP Connector (CN2).....	22

2.5.2	Audio Connector (J1)	23
2.5.3	SATA HDD Power Connector (J5)	23
2.5.4	Front Panel Connector (J6)	24
2.5.5	USB 2.0 Connector (J7)	25
2.5.6	Battery Connector (J10)	25
2.5.7	DC Power Input Connector (J13)	26
2.5.8	Digital I/O Connector (J16)	26
Chapter 3 Driver Installation		27
3.1	Introduction	28
3.2	Intel® Chipset Software Installation Utility	28
3.3	Graphics Driver Installation	29
3.4	HD Audio Driver Installation	30
3.5	LAN Driver Installation	31
3.6	Intel® Management Engine Driver Installation	33
Chapter 4 BIOS Setup		35
4.1	Introduction	36
4.2	BIOS Setup	36
4.3	Main Settings	37
4.4	Advanced Settings	38
4.5	Chipset Settings	55
4.6	Security Settings	57
4.7	Boot Settings	58
4.8	Save & Exit Settings	59
Appendix		60
A.	I/O Port Address Map	61
B.	Interrupt Request Lines (IRQ)	63
C.	Digital I/O Sample Code	64
D.	Watchdog Timer Configuration	68

Chapter 1

General Information

The information provided in this chapter includes:

- Features
- Packing List
- Optional Accessories
- Specifications
- Overview
- Dimensions

1.1 Introduction

The ASB200-916 is applicable to thin clients, smart industrial automation or controller, and retail equipment. It is a compact and fanless design with an Intel® 7th Gen. Core™ i7 / i5 / i3 U-series processor. This product also features iSmart, the IBase's unique technique, which allows the device capable of auto-scheduling for general applications and gives energy savings on power.



1.2 Features

- Fanless system with IBase 3.5" disk-size SBC
- Onboard Intel® 7th Gen. Core™ i7/i5/i3 U-series processor
- iSmart for auto-scheduler and power resume
- 1 x 2.5" SATA HDD, 1 x Mini-PCIe (full-size)
- 4 x USB 3.0, 1 x DisplayPort, 1 x HDMI
- 12 ~ 24V wide-range DC power input
- Wall mount kit included

1.3 Packing List

Your product package should include the items listed below. If any of the items below is missing, contact the distributor or the dealer from whom you purchased the product.

- ASB200-916 x 1
- 3-Pin Terminal Block (for power) x 1
- 10-Pin Terminal Block (for GPIO connector) x 1
- Wall Mount Kit (2 brackets) x 1
- Screws for Wall Mount Kit x 4
- Antenna x 2

1.4 Optional Accessories

IBASE provide optional accessories as follows. Please contact us or your dealer if you need any.

- VESA Mount Kit (with 4 screws)
- DC Power Jack
- Power Adapter and Power Cord (for DC power jack)

1.5 Specifications

Product Name	ASB200-916-i7	ASB200-916-i5	ASB200-916-i3
Motherboard	IB916AF-7600	IB916AF-7300	IB916F-7100
MB Form Factor	3.5" disk-size SBC		
System			
Operating System	<ul style="list-style-type: none"> Windows 10 Linux Ubuntu / Fedora 		
CPU	Intel® 7 th Gen. Core™ i7-7600U	Intel® 7 th Gen. Core™ i5-7300U	Intel® 7 th Gen. Core™ i3-7100U
CPU Speed	2.8 GHz	2.6 GHz	2.4 GHz
Memory	2 x DDR4-2133 SO-DIMM 4 GB, expandable to 32 GB		
Storage	1 x 2.5" HDD or SSD drive bay		
Super I/O	Fintek F81846AD-I		
Audio Codec	Realtek ALC662		
Network	<ul style="list-style-type: none"> Intel® I219LM GbE PHY Intel® I211AT as 2nd GbE 	<ul style="list-style-type: none"> Intel® I219V GbE PHY Intel® I211AT as 2nd GbE 	
Power Supply	90W power adaptor (Optional)		
BIOS	AMI BIOS		
Watchdog	Watchdog Timer 256 segments, 0, 1, 2...255 sec/min		
Chassis	Aluminum & steel, black		
Mounting	<ul style="list-style-type: none"> Desktop mount Wall mount VESA mount (Optional) 		
Dimensions (W x H x D)	180 x 66 x 150 mm (7.09" x 2.6" x 5.9")		
Weight	1.8 kg (3.97 lb)		
Certificate	CE / LVD / FCC Class B		
I/O Ports			
DC Input	12 ~ 24V DC-in through a 3-pin terminal block (Optional: a locking DC Jack)		
LAN	2 x RJ45 GbE LAN		
USB	<ul style="list-style-type: none"> 2 x USB 2.0 4 x USB 3.0 		

Serial	4 x COM ports: <ul style="list-style-type: none"> • COM1 port through RJ50 connector (RS-232/422/485, selectable from BIOS) • COM2/3/4 port through DB9 connector (RS-232 only)
Digital I/O	4-In & 4-Out
Display	<ul style="list-style-type: none"> • 1 x DisplayPort • 1 x HDMI
Audio Jack	<ul style="list-style-type: none"> • 1 x Microphone Input • 1 x Line-Out • 1 x Line-In
SATA	2 x SATA III connector
Expansion	1 x Mini-PCIe slot (full-size)
Environment	
Temperature	<ul style="list-style-type: none"> • Operating: with SSD: -20 ~ 60 °C (-4 ~ 140 °F) with HDD: 0 ~ 45 °C (32 ~ 113 °F) • Storage: -20~ 80 °C (-4 ~ 176 °F)
Relative Humidity	5 ~ 90% at 45 °C (non-condensing)
Vibration Protection	<ul style="list-style-type: none"> • Operating: 0.25 Grms / 5 ~ 500 Hz • Non-operating: 1 Grms / 5 ~ 500Hz
Shock Protection	<ul style="list-style-type: none"> • Operating: 20 g / 11 ms • Non-operating: 40 g / 11 ms

All specifications are subject to change without prior notice.

1.6 Overview

Front View



No.	Name	No.	Name
1	Digital I/O Connector (4-In / 4-Out)	4	Power Button
2	Audio Jacks (From left to right: Mic-In, Line-In, Lin-Out)	5	HDD LED Indicator
3	USB 2.0 Ports		

Rear View

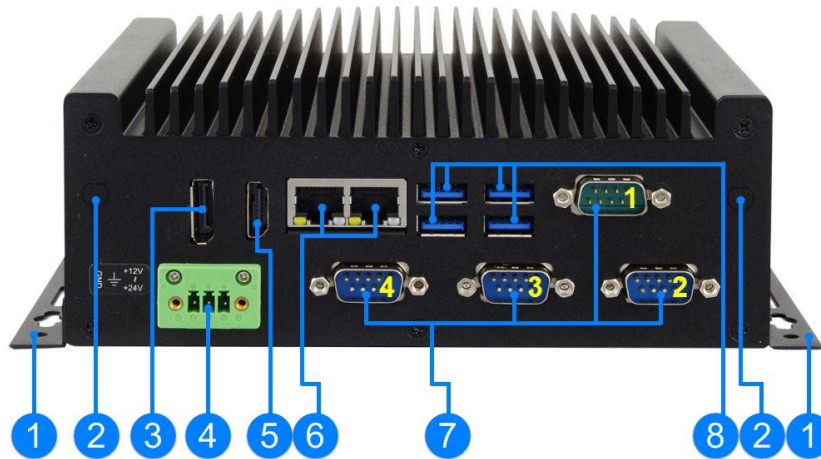

No.	Name	No.	Name
1	Wall Mount Kit (2 brackets)	5	HDMI Port
2	Antenna Holes	6	GbE LAN Ports
3	DisplayPort	7	COM1 ~ COM4 Ports (COM1: RS-232/422/485, COM2 ~ COM4: RS-232)
4	DC-In Power Connector	8	USB 3.0 Ports

Oblique View



1.7 Dimensions

Unit: mm

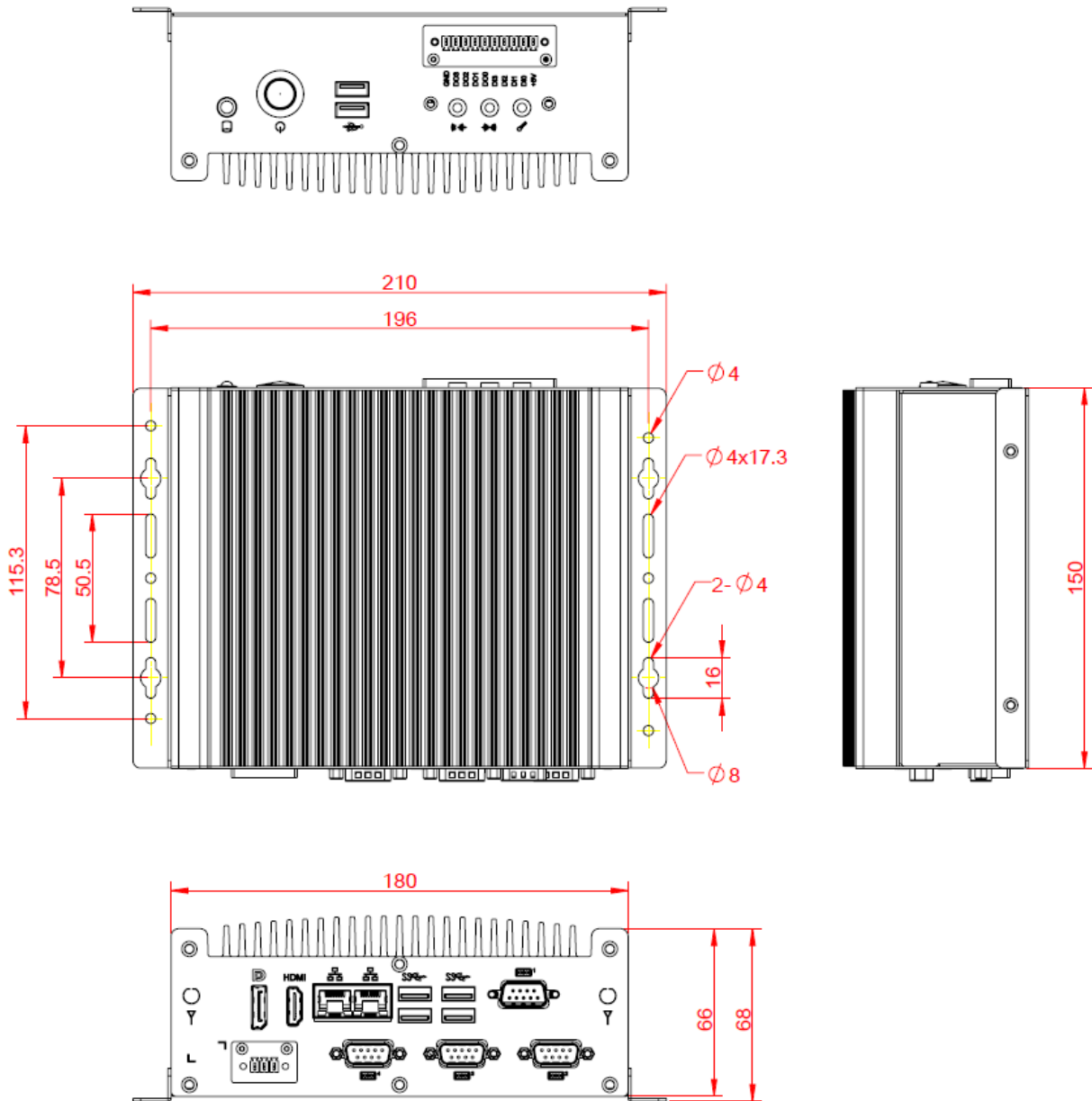

Chapter 2

Hardware Configuration

The information provided in this chapter includes:

- Installations
- Information and locations of connectors

2.1 Installations

Before installations, you need to remove the bottom chassis cover by loosen 6 screws from the device and pull out the cover.

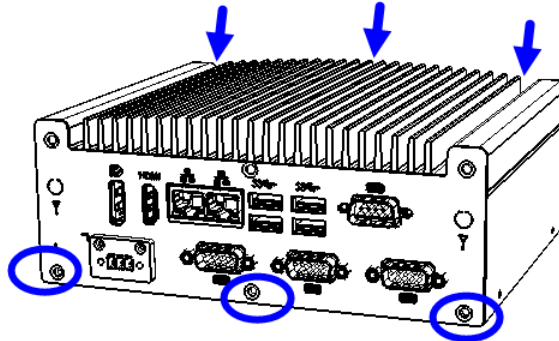

2.1.1 HDD Installation

If you need to install or replace an SSD or a HDD, follow the instructions below for installation after you remove the device cover.

1. Loosen 4 screws below.
2. Attach your SSD / HDD and tighten these screws.

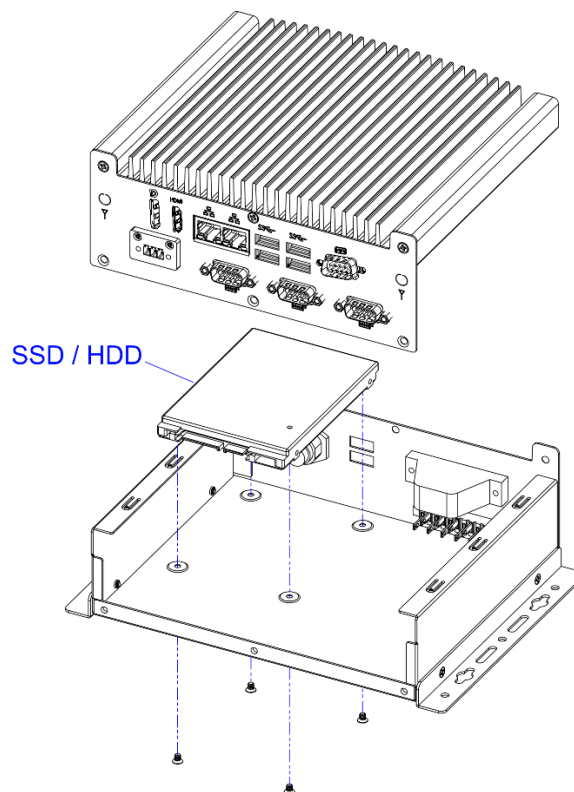

2.1.2 Memory Installation

If you need to install or replace a memory module, perform the following steps:

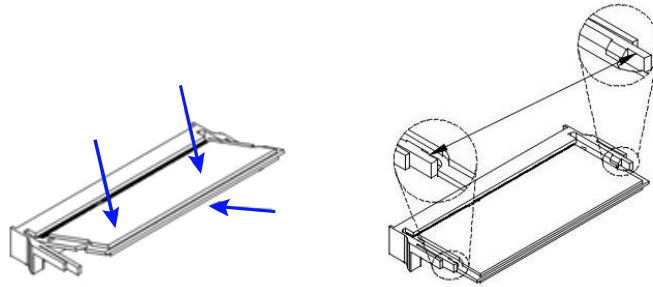

1. Locate the memory slot on the board.
2. Align the key of the memory module with that on the memory slot and insert the module slantwise.
3. Gently push the module down in an upright position until the clips of the slot close to hold the module in place when the module touches the bottom of the slot.

To remove the module, press the clips outwards with both hands, and the module will pop-up.

2.1.3 Mini-PCIe Card Installation

If you need to use a mini-PCIe card for expansion slots, follow the instructions below for installation after you remove the device bottom chassis cover.

1. Align the key of the mini-PCIe card to the mini-PCIe interface, and insert the card slantwise.

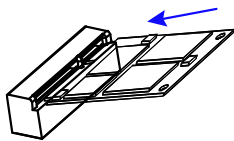

2. Push the mini-PCIe card down, fix it onto the standoff with a screw.

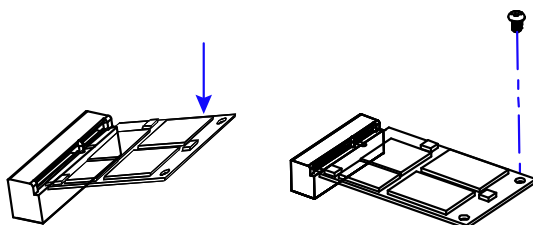

2.1.4 WiFi / 3G / 4G Antenna Installation

Thread the WiFi / 3G / 4G antenna cable through an antenna hole. Then fasten the antenna as shown below.

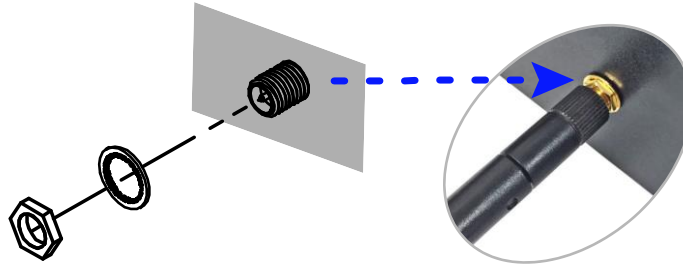

Info: The diameter of the nut is around 6.35 mm (0.25"-36UNC).

2.1.5 Wall Mounting Installation

Requirements

Before mounting the system, ensure that you have enough room for the power adaptor and signal cable routing, and have good ventilation for the power adaptor. The method of mounting must be able to support weight of the SI-61S plus the weight of the suspending cables attached to the system. Use the following methods for mounting your system:

1. Attach the mounting brackets to your ASB200-916, and secure with the supplied 4 screws.
2. Prepare at least 4 screws (M3) to install the device on wall .

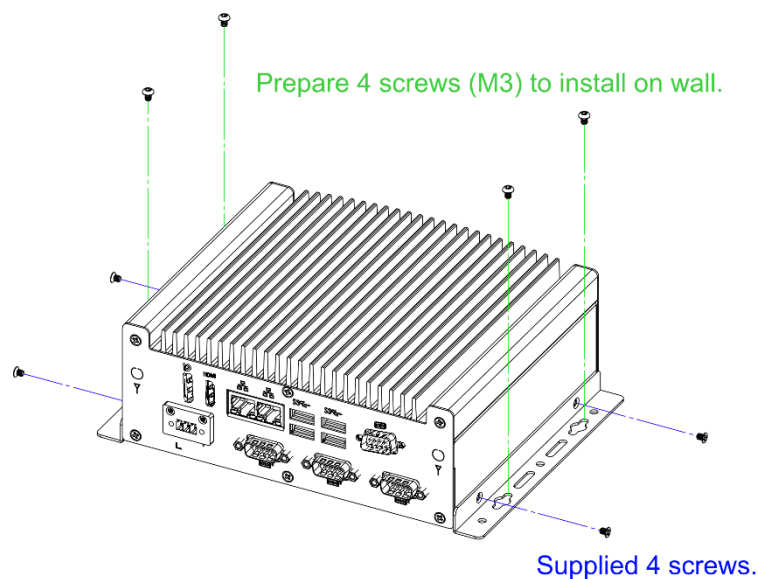

2.1.6 VESA Mount Installation

1. VESA mounting ASB200-916.

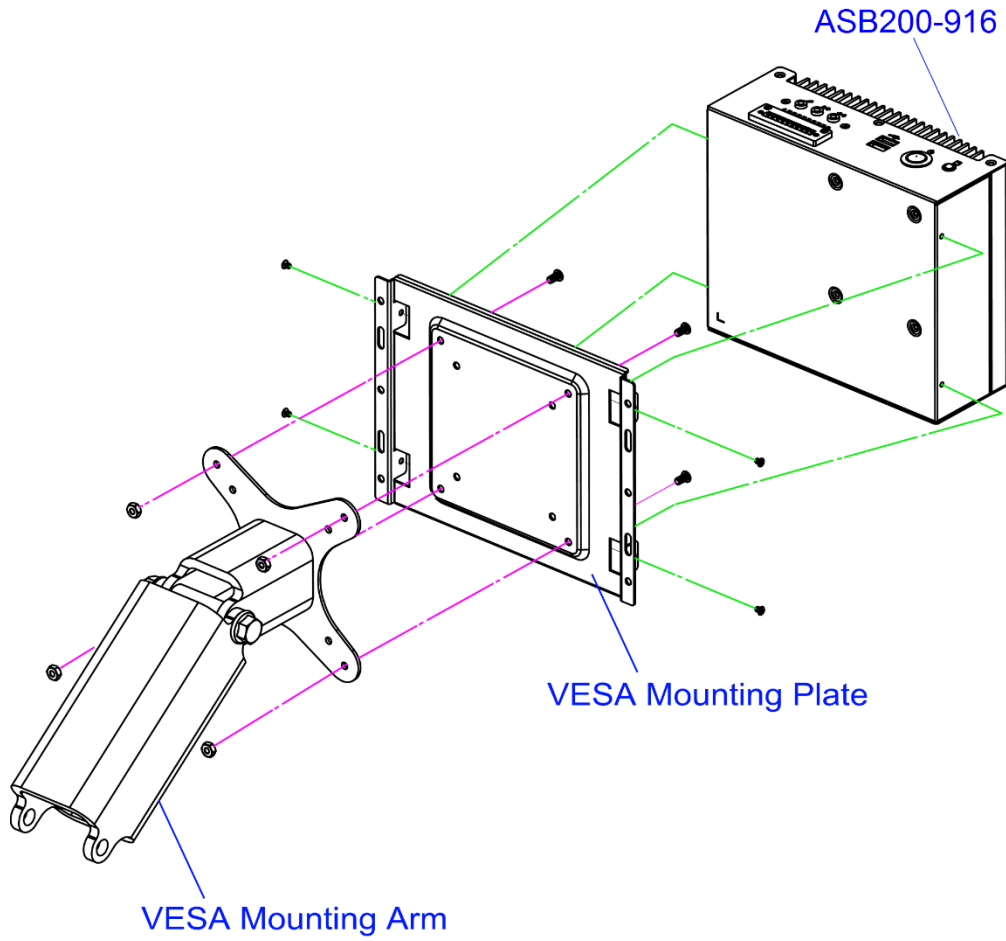

2. VESA mounting ASB200-916 to a panel

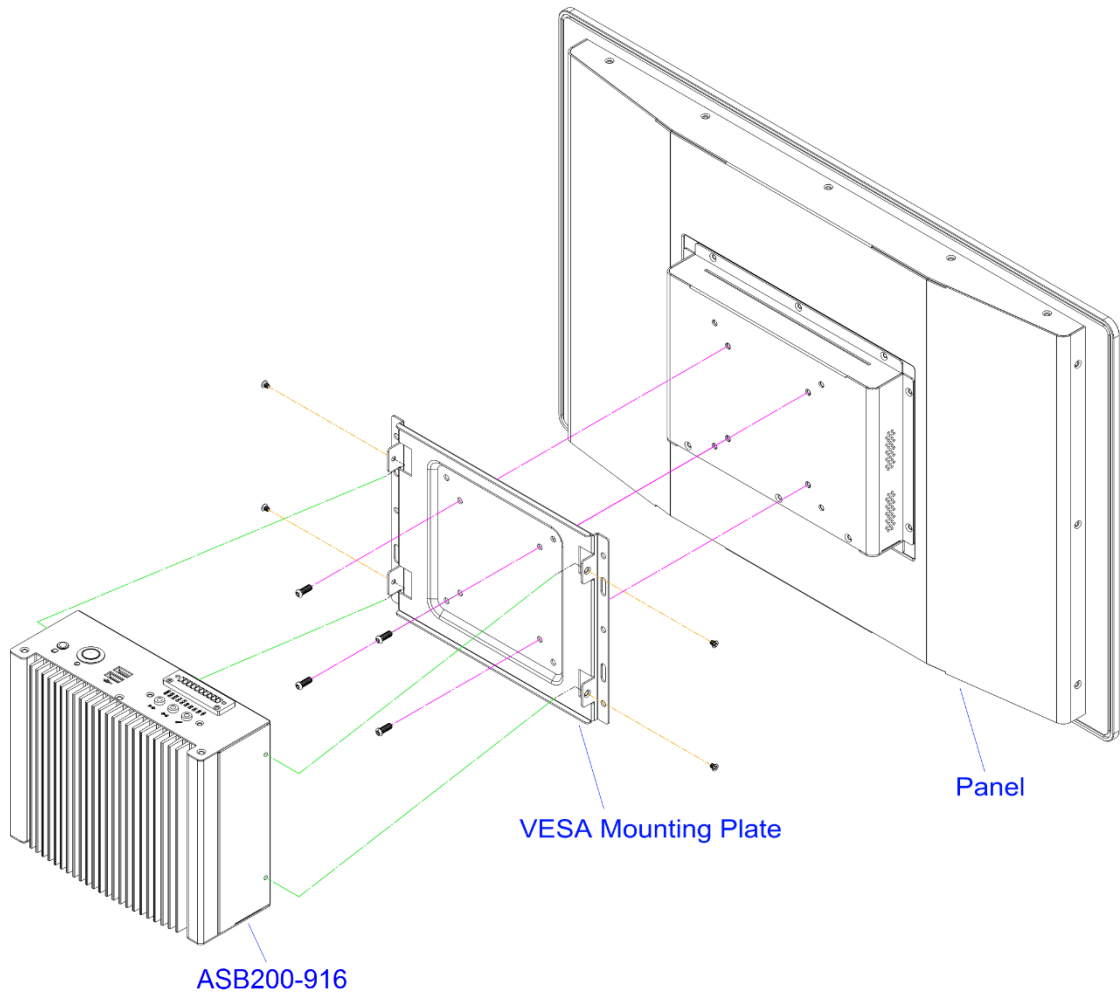

2.1.7 Pinout for COM Ports, DC Power & Digital I/O Connectors

- **COM1 RS232/422/485 Port**



COM1 port is jumper-less and configurable in BIOS.

Pin	Assignment	Pin	Assignment
1	DCD, Data carrier detect	6	DSR, Data set ready
2	RXD, Receive data	7	RTS, Request to send
3	TXD, Transmit data	8	CTS, Clear to send
4	DTR, Data terminal ready	9	RI, Ring indicator
5	Ground		

Pin	Assignment		
	RS-232	RS-422	RS-485
1	DCD	TX-	DATA-
2	RX	TX+	DATA+
3	TX	RX+	NC
4	DTR	RX-	NC
5	Ground	Ground	Ground
6	DSR	NC	NC
7	RTS	NC	NC
8	CTS	NC	NC
9	RI	NC	NC

- **COM2 / COM3 / COM4 (DB-9) RS-232 Ports**



Pin	Assignment	Pin	Assignment
1	DCD, Data carrier detect	6	DSR, Data set ready
2	RXD, Receive data	7	RTS, Request to send
3	TXD, Transmit data	8	CTS, Clear to send
4	DTR, Data terminal ready	9	RI, Ring indicator
5	Ground		

- **DC Power Input Connector (terminal block)**



Pin	Assignment	Pin	Assignment
1	Ground	3	+12V ~ +24V
2	Chassis Ground		

- **Digital I/O Connector (terminal block)**

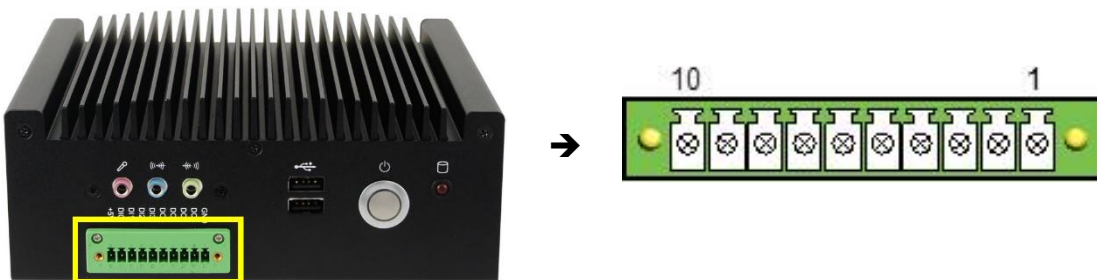

Pin	Assignment	Pin	Assignment
1	Ground	6	DI3
2	DO3	7	DI2
3	DO2	8	DI1
4	DO1	9	DI0
5	DO0	10	+5V

2.2 Setting the Jumpers

Set up and configure your product by using jumpers for various settings and features according to your needs and applications. Contact your supplier if you have doubts about the best configuration for your use.

2.2.1 How to Set Jumpers

Jumpers are short-length conductors consisting of several metal pins with a non-conductive base mounted on the circuit board. Jumper caps are used to have the functions and features enabled or disabled. If a jumper has 3 pins, you can connect either PIN1 to PIN2 or PIN2 to PIN3 by shorting.

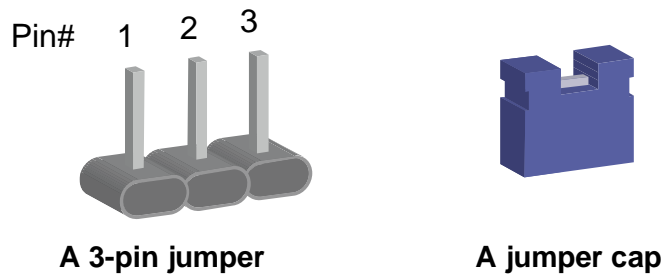

Refer to the illustration below to set jumpers.

Pin closed	Oblique view	Schematic illustration in the manual
Open		
1-2		
2-3		

When two pins of a jumper are encased in a jumper cap, this jumper is **closed**, i.e. turned **On**.

When a jumper cap is removed from two jumper pins, this jumper is **open**, i.e. turned **Off**.

2.3 Jumper & Connector Locations on Motherboard

Motherboard: IB916

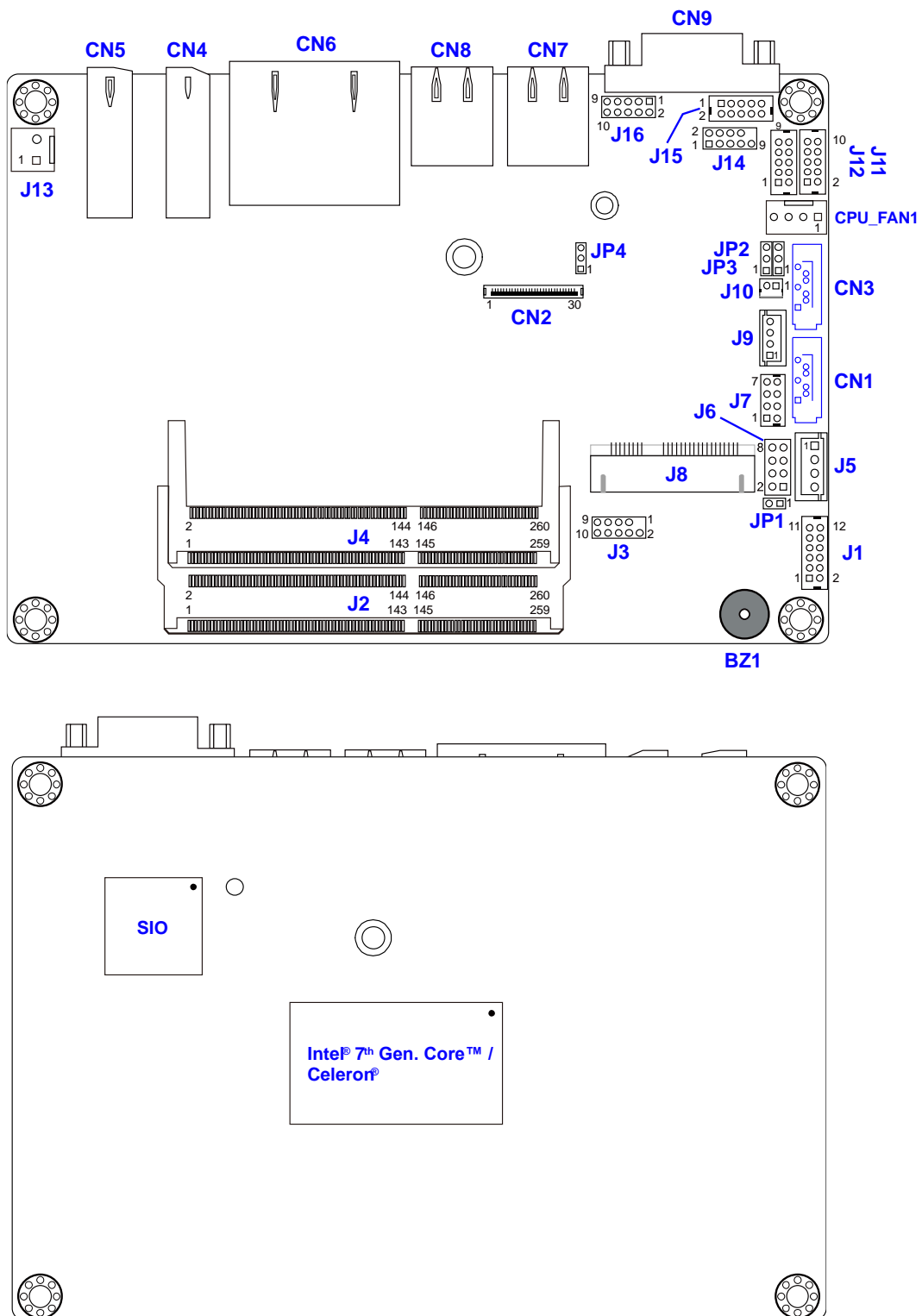

Board diagram of IB916

2.4 Jumpers Quick Reference

Function	Connector Name	Page
CMOS Data Clearance	JP2	19
ME Register Clearance	JP3	20
eDP Panel Power Selection	JP4	20
Factory Use Only	JP1	- -

2.4.1 Clearing CMOS Data (JP2)

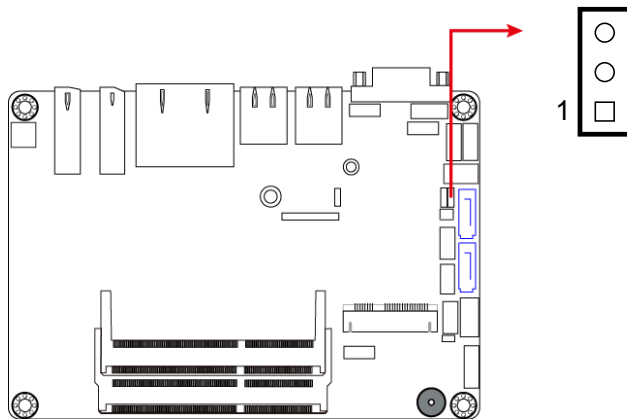

Function	Pin closed	Illustration
Normal (default)	1-2	
Clear CMOS	2-3	

2.4.2 Clearing ME Register (JP3)

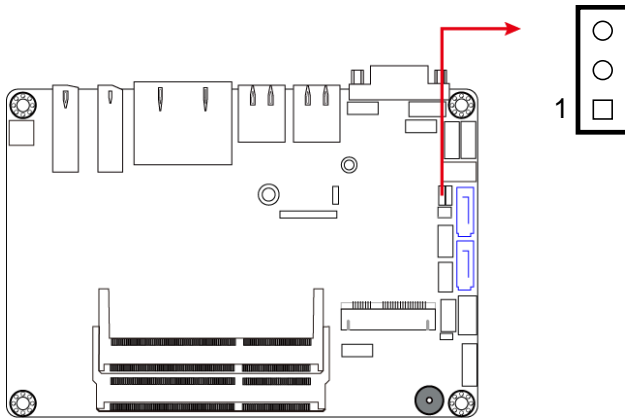

Function	Pin closed	Illustration
Normal (default)	1-2	
Clear ME	2-3	

2.4.3 eDP Panel Power Selection (JP4)

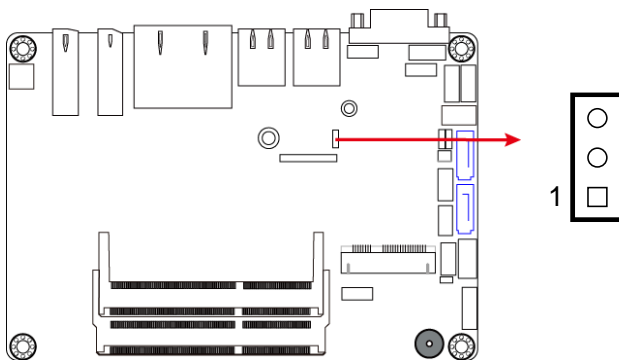

Function	Pin closed	Illustration
3.3V (default)	1-2	
5V	2-3	

2.5 Connectors Quick Reference

Function	Connector Name	Page
eDP Connector	CN2	22
Audio Connector	J1	23
SATA HDD Power Connector	J5	23
Front Panel Setting Connector	J6	24
USB 2.0 Connector	J7	25
Battery Connector	J10	25
DC Power Input Connector	J13	26
Digital I/O Connector	J16	26
COM1 RS-232/422/485 Port ^[1]	CN9	--
COM2, COM3, COM4 RS-232 Ports ^[1]	J15, J12, J11	--
SATA III Port	CN1, CN3	--
HDMI 1.4 Port	CN4	--
Display Port	CN5	--
GbE LAN Ports	CN6	--
USB 3.0 Port	CN7, CN8	--
DDR4 SO-DIMM Slot	J2, J4	--
Mini-PCIe / mSATA Slot	J8	--
Factory Use Only	J3, J9, J14	--

[1]: Refer to 2.1.7 Pinout for COM Ports, DC Power & Digital I/O Connectors.

2.5.1 eDP Connector (CN2)

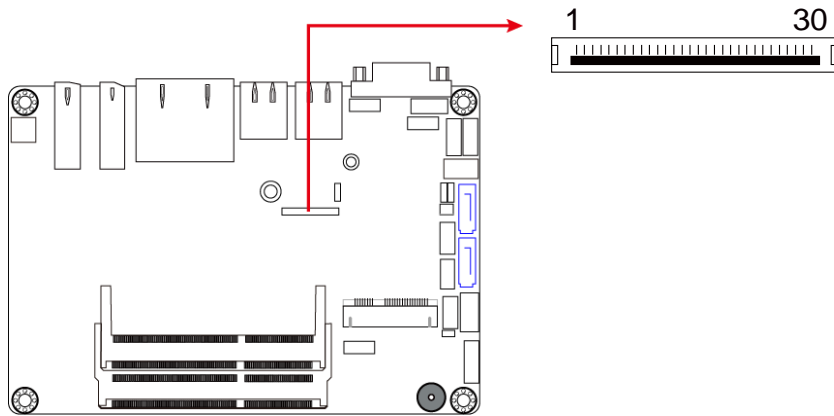

Pin	Assignment	Pin	Assignment
1	NC	16	Ground
2	BL_Power	17	NC
3	BL_Power	18	Panel_VDD
4	BL_Power	19	Panel_VDD
5	BL_Power	20	Ground
6	NC	21	AUX_N
7	NC	22	AUX_P
8	Brightness	23	Ground
9	Bklt_en	24	TX0_P
10	Ground	25	TX0_N
11	Ground	26	Ground
12	Ground	27	TX1_P
13	Ground	28	TX1_N
14	HPD	29	Ground
15	Ground	30	NC

2.5.2 Audio Connector (J1)

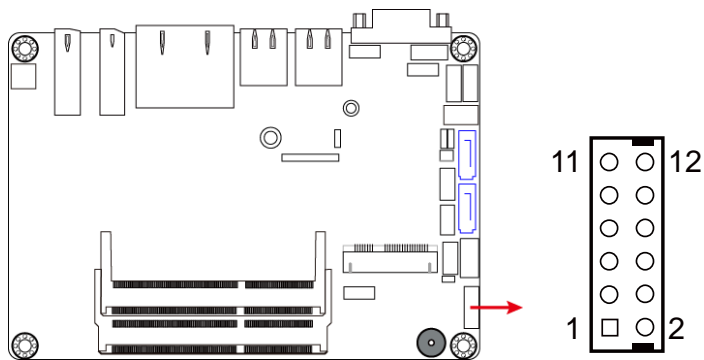

Pin	Assignment	Pin	Assignment
1	Lineout_L	2	Lineout_R
3	JD_FRONT	4	Ground
5	LINEIN_L	6	Linein_R
7	JD_LINEIN	8	Ground
9	MIC_L	10	MIC-R
11	JD_MIC1	12	Ground

2.5.3 SATA HDD Power Connector (J5)

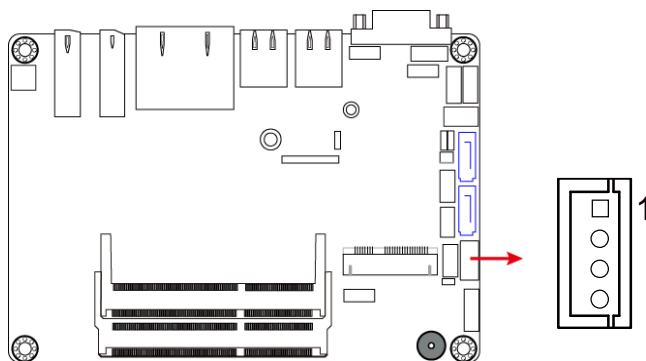

Pin	Assignment	Pin	Assignment
1	+5V	3	Ground
2	Ground	4	+12V

2.5.4 Front Panel Connector (J6)

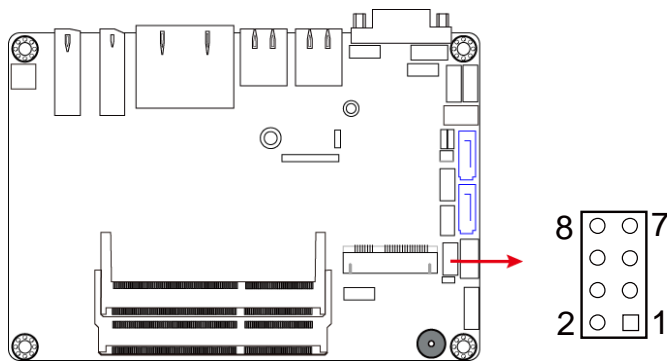

Pin	Assignment	Pin	Assignment
1	Ground	2	PWR_BTN
3	3.3V	4	HDD Active
5	Ground	6	Reset
7	+5V	8	Ground

J6 is utilized for system indicators to provide light indication of the computer activities and switches to change the computer status. It provides interfaces for the following functions.

- ATX Power ON Switch (Pins 1 and 2)**
 The 2 pins make an “ATX Power Supply On/Off Switch” for the system that connects to the power switch on the case. When pressed, the power switch will force the system to power on. When pressed again, it will power off the system.
- Hard Disk Drive LED Connector (Pins 3 and 4)**
 This connector connects to the hard drive activity LED on control panel. This LED will flash when the HDD is being accessed.
- Reset Switch (Pins 5 and 6)**
 The reset switch allows you to reset the system without turning the main power switch off and then on again. Orientation is not required when making a connection to this header.
- Power LED: Pins 7 and 8**
 This connector connects to the system power LED on control panel. This LED will light when the system turns on.

2.5.5 USB 2.0 Connector (J7)

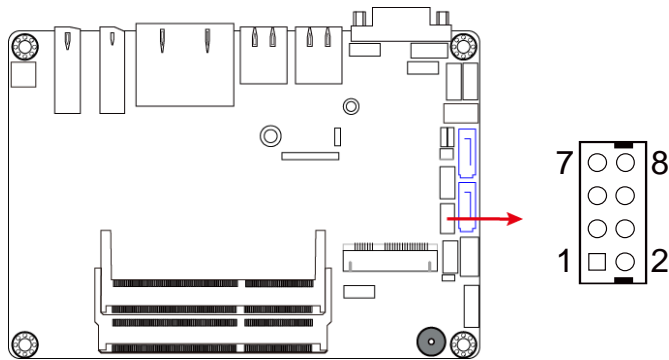

Pin	Assignment	Pin	Assignment
1	VCC	2	Ground
3	D0-	4	D1+
5	D0+	6	D1-
7	Ground	8	VCC

2.5.6 Battery Connector (J10)

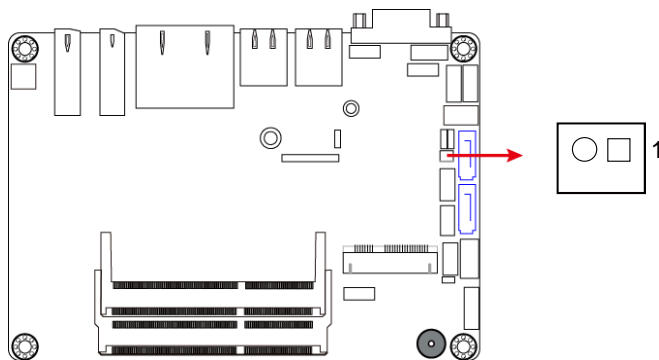

Pin	Assignment	Pin	Assignment
1	Battery+	2	Ground

2.5.7 DC Power Input Connector (J13)

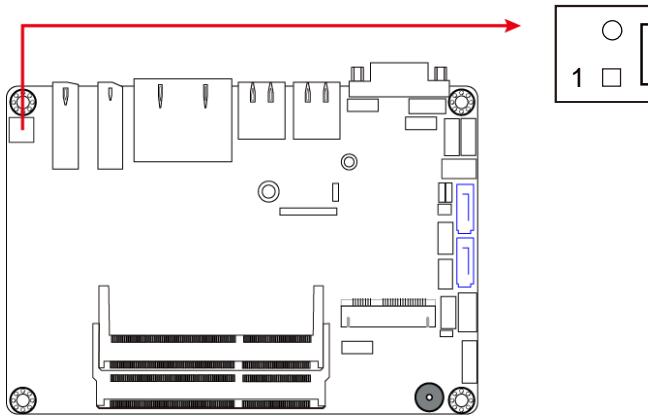

Pin	Assignment	Pin	Assignment
1	+9V ~ +24V	2	Ground

2.5.8 Digital I/O Connector (J16)

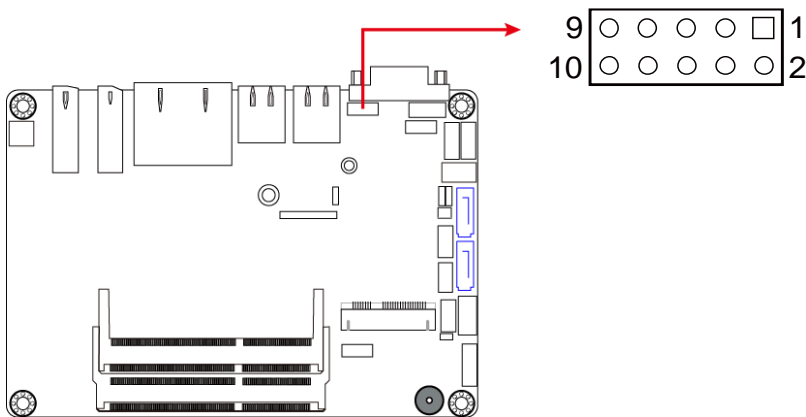

Pin	Assignment	Pin	Assignment
1	Ground	2	VCC
3	OUT3	4	OUT1
5	OUT2	6	OUT0
7	IN3	8	IN1
9	IN2	10	IN0

Chapter 3

Driver Installation

The information provided in this chapter includes:

- Intel® Chipset Software Installation Utility
- Graphics Driver Installation
- HD Audio Driver Installation
- LAN Driver Installation
- Intel® Management Engine Driver Installation

3.1 Introduction

This section describes the installation procedures for software drivers.

Note: After installing your Windows operating system, you must install the Intel® Chipset Software Installation Utility first before proceeding with the drivers installation.

3.2 Intel® Chipset Software Installation Utility

The Intel® Chipset drivers should be installed first before the software drivers to install INF files for Plug & Play function for the chipset components. Follow the instructions below to complete the installation.

1. Go to the download page of the product. Copy the compressed drivers file to your computer. Double click the file to decompress it. Run “CDGuide” to go to the main drivers page as shown. Click **Intel** on the left pane and then **Intel(R) Kabylake-U Chipset Drivers** on the right pane.



2. Click **Intel(R) Chipset Software Installation Utility**.



3. When the *Welcome* screen to the Intel® Chipset Device Software appears, click **Next** to continue.
4. Accept the software license agreement and proceed with the installation process.
5. On the *Readme File Information* screen, click **Next** for installation.

- When the driver is completely installed, restart the computer for changes to take effect.

3.3 Graphics Driver Installation

- Click **Intel** on the left pane and then **Intel(R) Kabylake-U Chipset Drivers**.

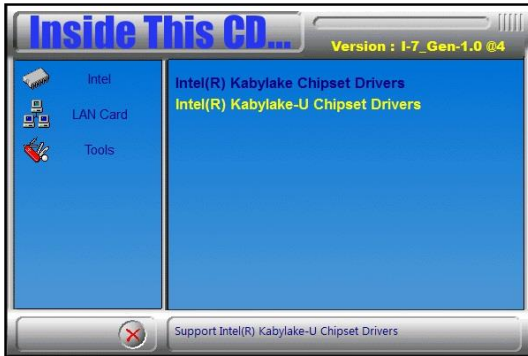

- Click **Intel(R) HD Graphics Driver**.



- When the *Welcome* screen appears, click **Next**.

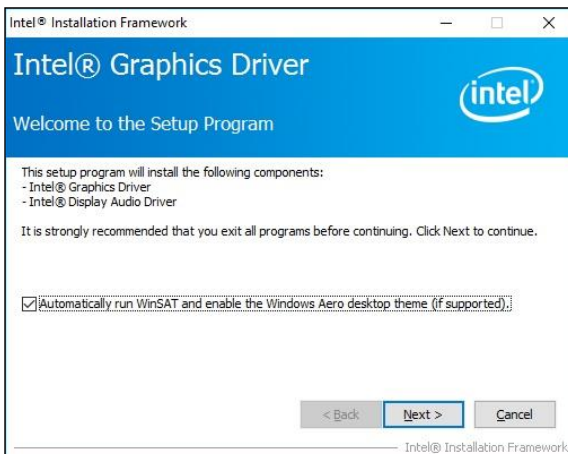

- Click **Yes** to accept the license agreement and click **Next**.
- On the *Readme File Information* screen, click **Next** until installation starts.
- When the driver is completely installed, restart the computer

3.4 HD Audio Driver Installation

1. Click **Intel** and then **Intel(R) Kabylake-U Chipset Drivers**.

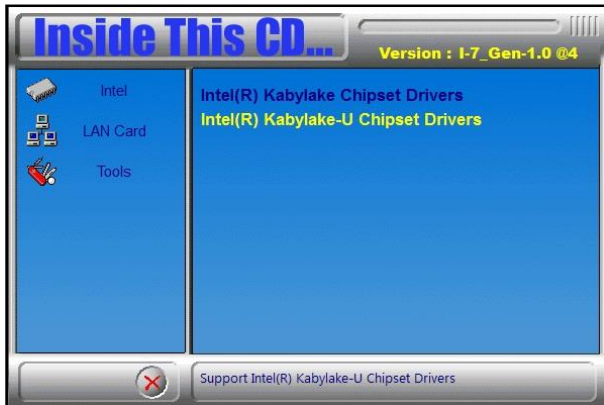

2. Click **Realtek High Definition Audio Driver**.



3. On the *Welcome* screen of the InstallShield Wizard, click **Next** until the installation starts.

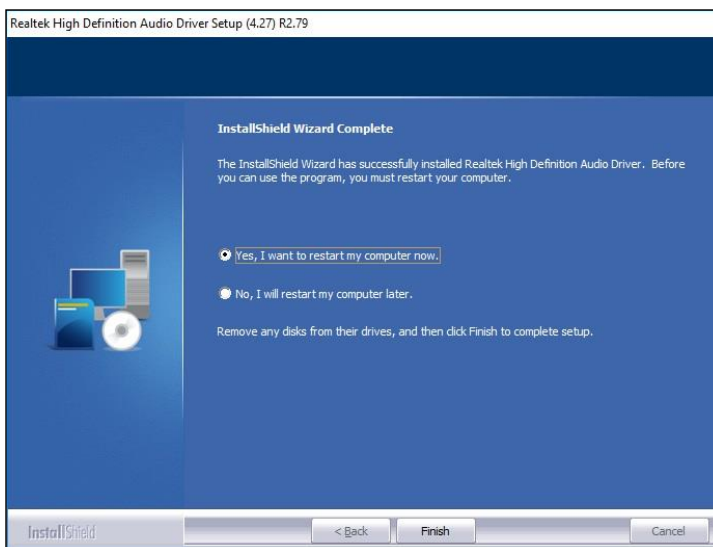

4. When the driver is completely installed, restart the computer for changes to take effect.

3.5 LAN Driver Installation

1. Click **LAN Card** and then **Intel(R) Kabylake-U Chipset Drivers**



2. Click **Intel(R) PRO LAN Network Drivers..**



3. When the *Welcome* screen appears, click **Next** to continue.

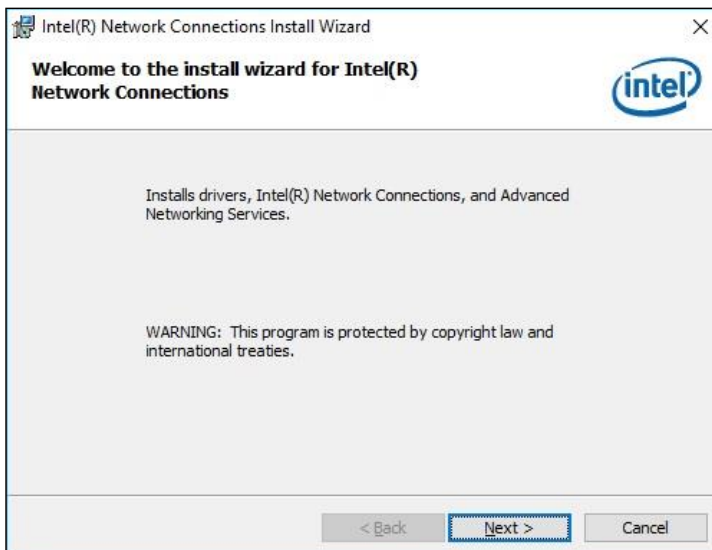

4. Accept the license agreement and click **Next**.

5. Tick the checkbox for **Drivers** to select the related drivers and click **Next**.

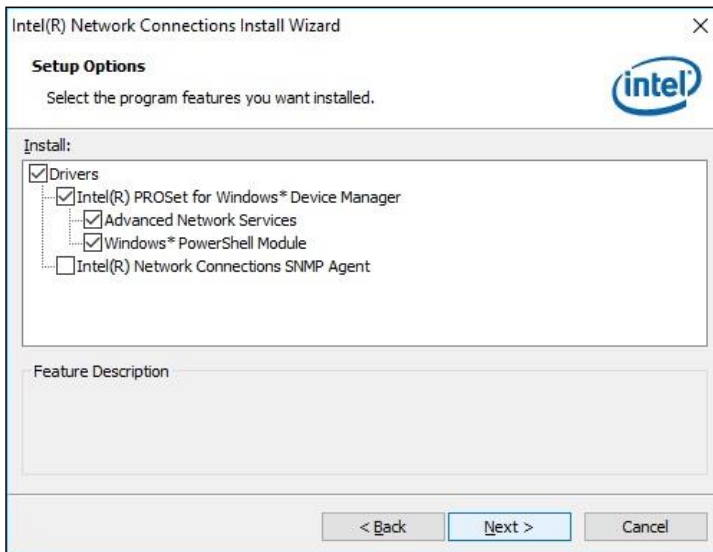

6. When the wizard is ready for installation, click **Install**.
7. As the installation is complete, restart the computer for changes to take effect.

3.6 Intel® Management Engine Driver Installation

1. Click **Intel** and then **Intel(R) Kabylake-U Chipset Drivers**.



2. Click **Intel(R) ME 11.x Drivers**.



3. When the *Welcome* screen appears, click **Next** to continue.

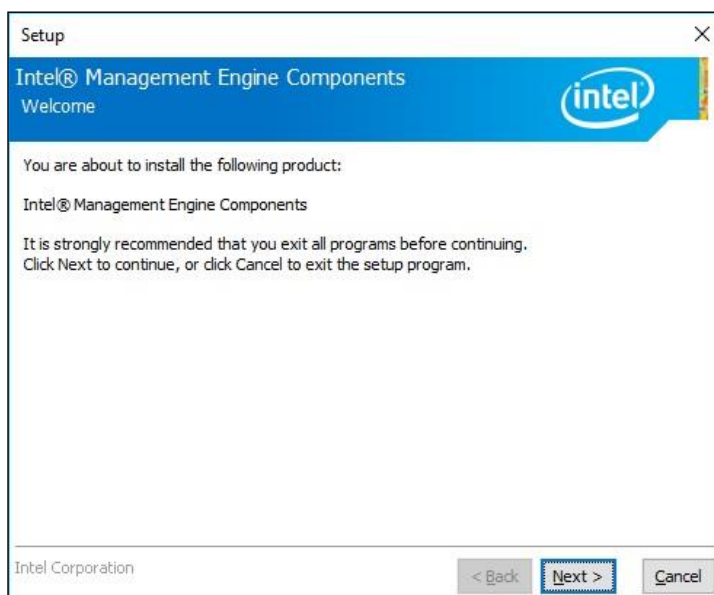

4. Accept the licence agreement and click **Next** until the installation starts.

iBASE

5. As the driver is completely installed, restart the computer for changes to take effect.

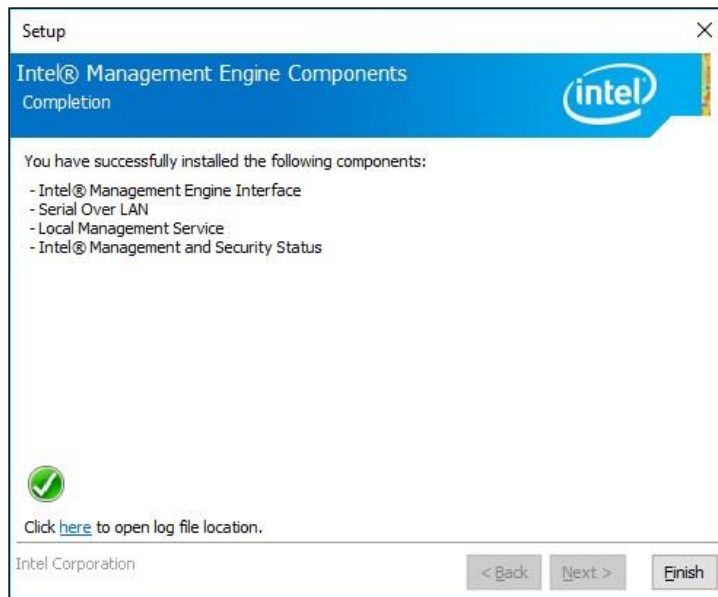

Chapter 4

BIOS Setup

This chapter describes the different settings available in the AMI BIOS that comes with the board. The topics covered in this chapter are as follows:

- Main Settings
- Advanced Settings
- Chipset Settings
- Security Settings
- Boot Settings
- Save & Exit

4.1 Introduction

The BIOS (Basic Input/Output System) installed in the ROM of your computer system supports Intel® processors. The BIOS provides critical low-level support for standard devices such as disk drives, serial ports and parallel ports. It also provides password protection as well as special support for detailed fine-tuning of the chipset controlling the entire system.

4.2 BIOS Setup

The BIOS provides a Setup utility program for specifying the system configurations and settings. The BIOS ROM of the system stores the Setup utility. When you turn on the computer, the BIOS is immediately activated. Press the key immediately allows you to enter the Setup utility. If you are a little bit late pressing the key, POST (Power On Self Test) will continue with its test routines, thus preventing you from invoking the Setup.

If you still need to enter Setup, restart the system by pressing the "Reset" button or simultaneously pressing the <Ctrl>, <Alt> and <Delete> keys. You can also restart by turning the system Off and back On again.

The following message will appear on the screen:

```
Press <DEL> to Enter Setup
```

In general, press the arrow keys to highlight items, <Enter> to select, the <PgUp> and <PgDn> keys to change entries, <F1> for help, and <Esc> to quit.

When you enter the BIOS Setup utility, the *Main Menu* screen will appear on the screen. The Main Menu allows you to select from various setup functions and exit choices.

Warning: It is strongly recommended that you avoid making any changes to the chipset defaults.

These defaults have been carefully chosen by both AMI and your system manufacturer to provide the absolute maximum performance and reliability. Changing the defaults could make the system unstable and crash in some cases.

4.3 Main Settings

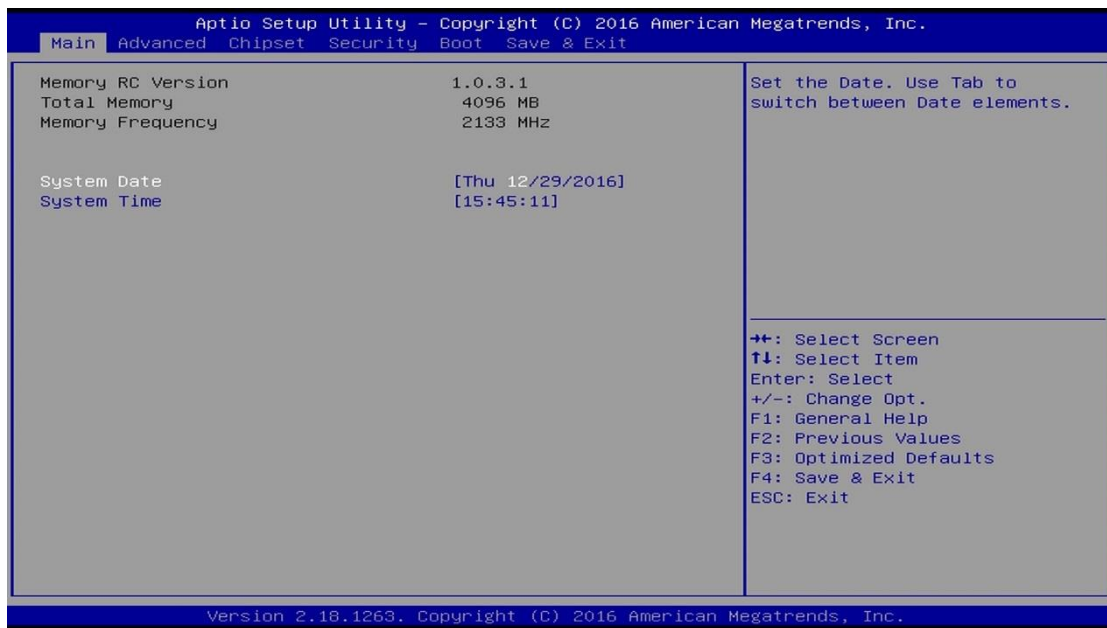

BIOS Setting	Description
System Date	Sets the date. Use the <Tab> key to switch between the date elements.
System Time	Set the time. Use the <Tab> key to switch between the time elements.

4.4 Advanced Settings

This section allows you to configure, improve your system and allows you to set up some system features according to your preference.

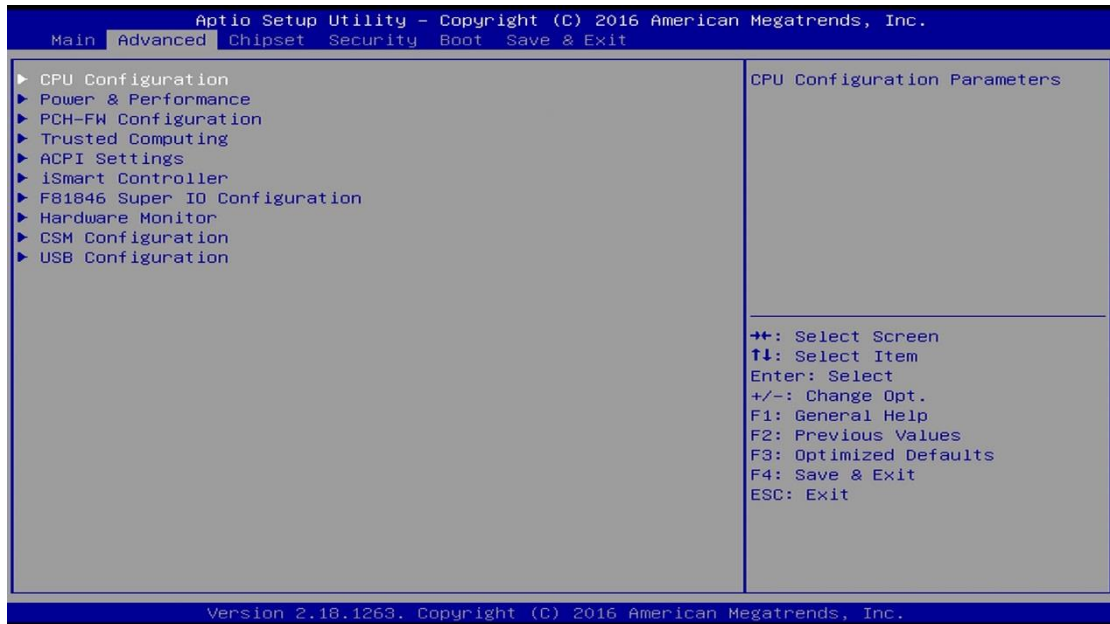

4.4.1 CPU Configuration

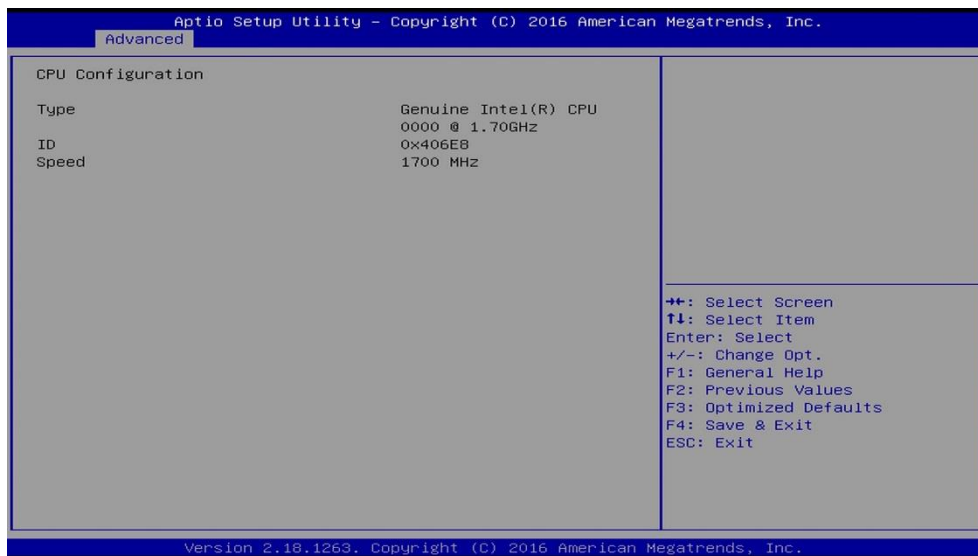

Displays the type, ID and speed of the CPU.

Note: The CPU information displayed varies upon the actual CPU type you use.

4.4.2 Power & Performance

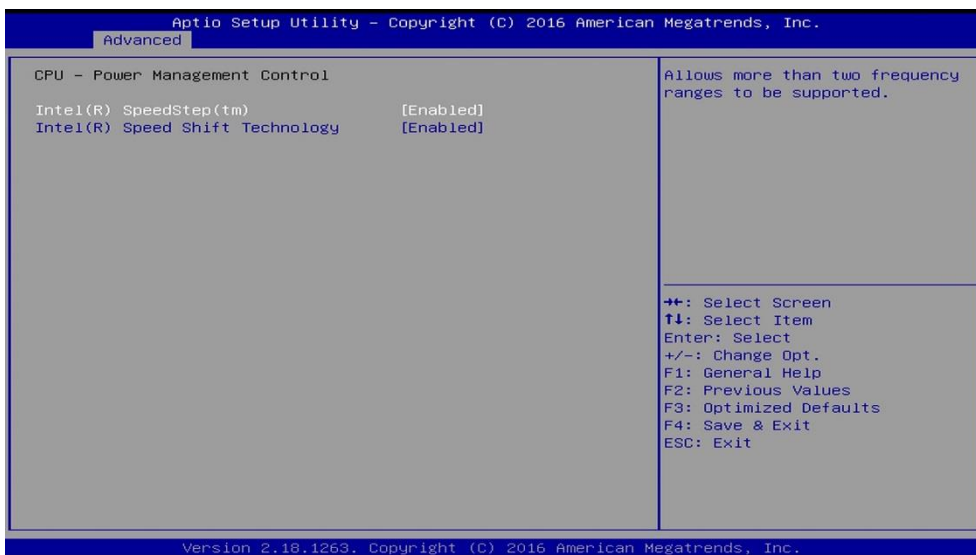
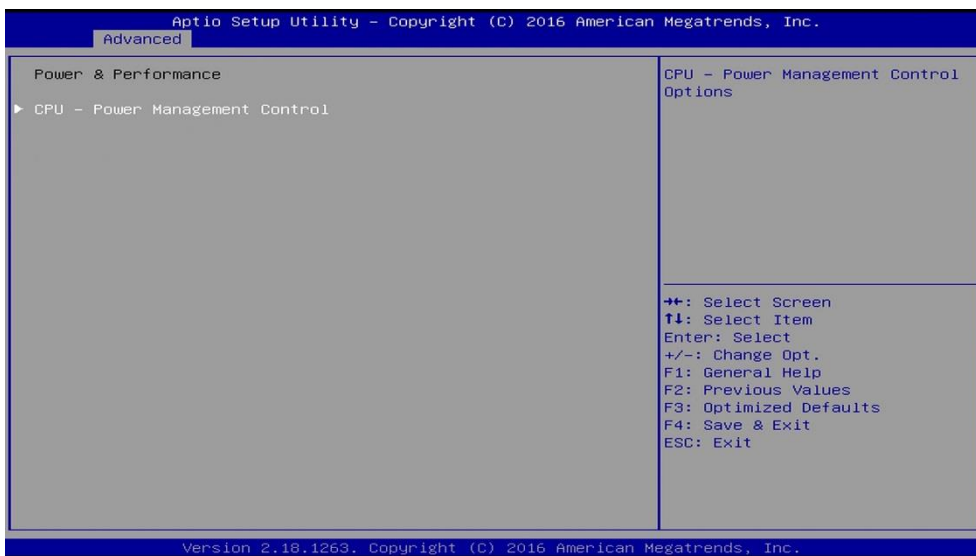

BIOS Setting	Description
Intel(R) SpeedStep(tm)	Allows more than two frequency ranges to be supported.
Intel(R) Speed Shift Technology	Enables / Disables Intel(R) Speed Shift Technology support. Enabling will expose the CPPC v2 interface to allow for hardware controlled P-states.

4.4.3 PCH-FW Configuration

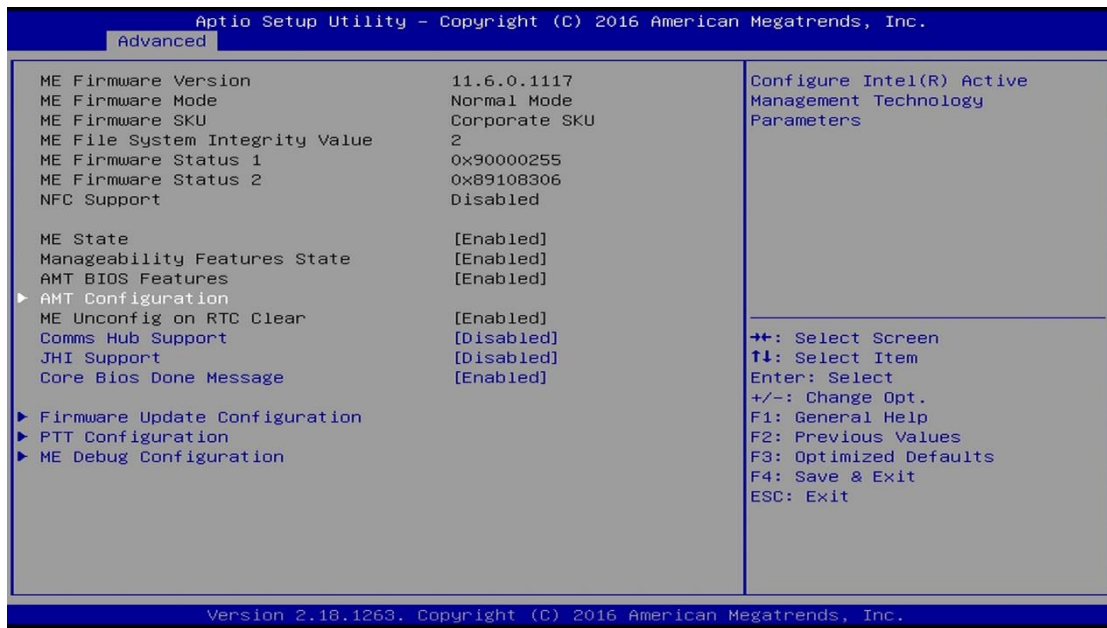

BIOS Setting	Description
AMT Configuration	Configures Intel(R) Active Management Technology Parameters.
Comms Hub Support	Enables / Disables support for Comms Hub.
JHI Support	Enables / Disables Intel(R) DAL Host Interface Service (JHI).
Core BIOS Done Message	Enables / Disables Core BIOS done message sent to ME.
Firmware Update Configuration	Configures Management Engine Technology parameters.
PTT Configuration	Configures PTT capability or state.
ME Debug Configuration	Configures ME debug options. Note: This menu is provided for testing purposes. It is recommended to leave the options in their default states.

4.4.4 AMT Configuration

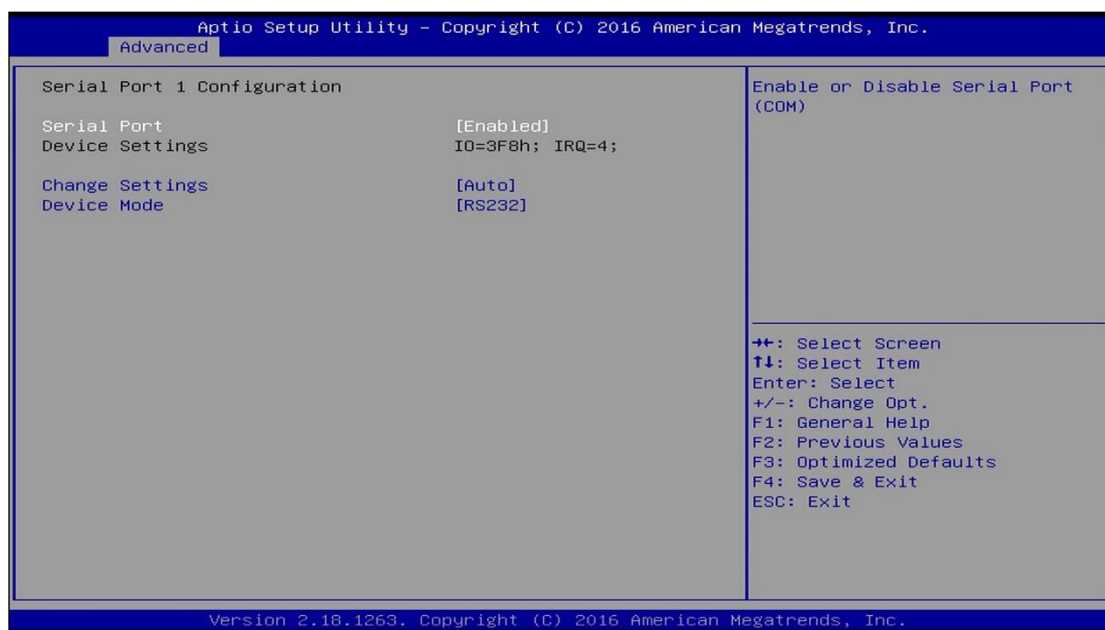

BIOS Setting	Description
ASF Support	Enables / Disables Alert Standard Format support.
USB Provisioning of AMT	Enables / Disables of AMT USB provisioning.
CIRA Configuration	Configures remote assistance process parameters.
ASF Configuration	Configures Alert Standard Format parameters.
Secure Erase Configuration	Secures erase configuration menu.
OEM Flags Settings	Configures OEM Flags.
MEBx Resolution Settings	Shows resolution settings for MEBx display modes.

4.4.4.1. ASF Configuration

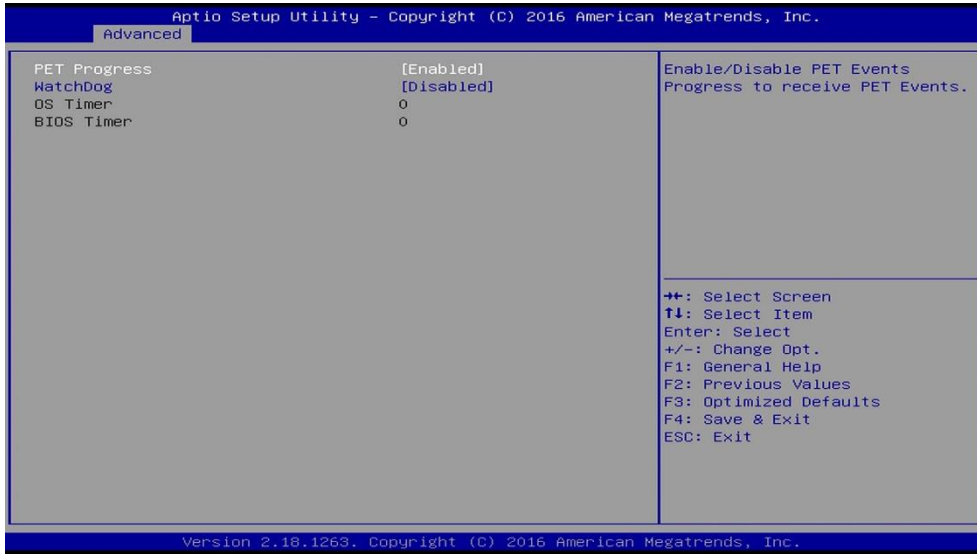

BIOS Setting	Description
PET Progress	Enables / Disables PET events progress to receive PET events.
WatchDog	Enables / Disables the watchdog timer.

4.4.4.2. Secure Erase Configuration

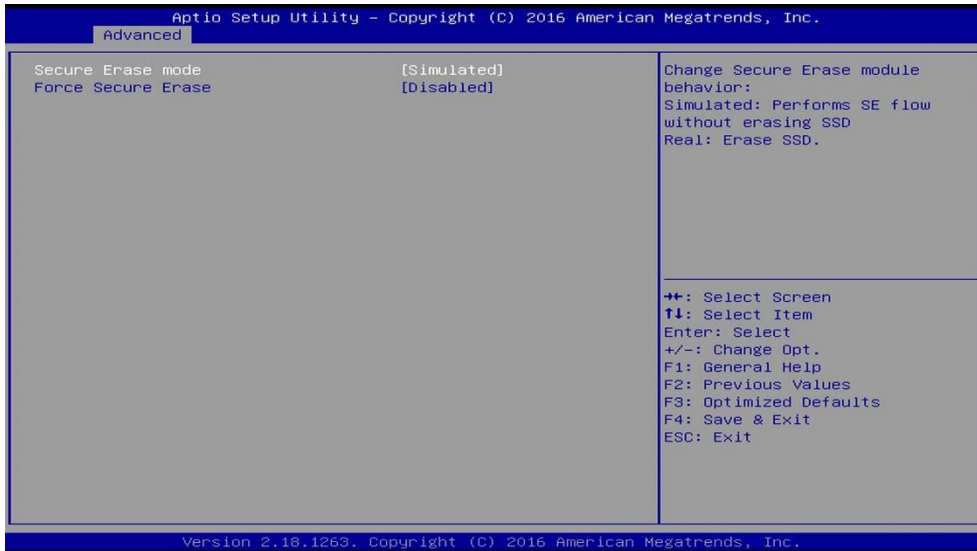

BIOS Setting	Description
Secure Erase Mode	Changes Secure Erase module behavior. <ul style="list-style-type: none"> • Simulated performs SE flow without erasing SSD. • Real erases SSD.
Force Secure Erase	Force Secure Erase on next boot.

4.4.4.3. OEM Flags Settings

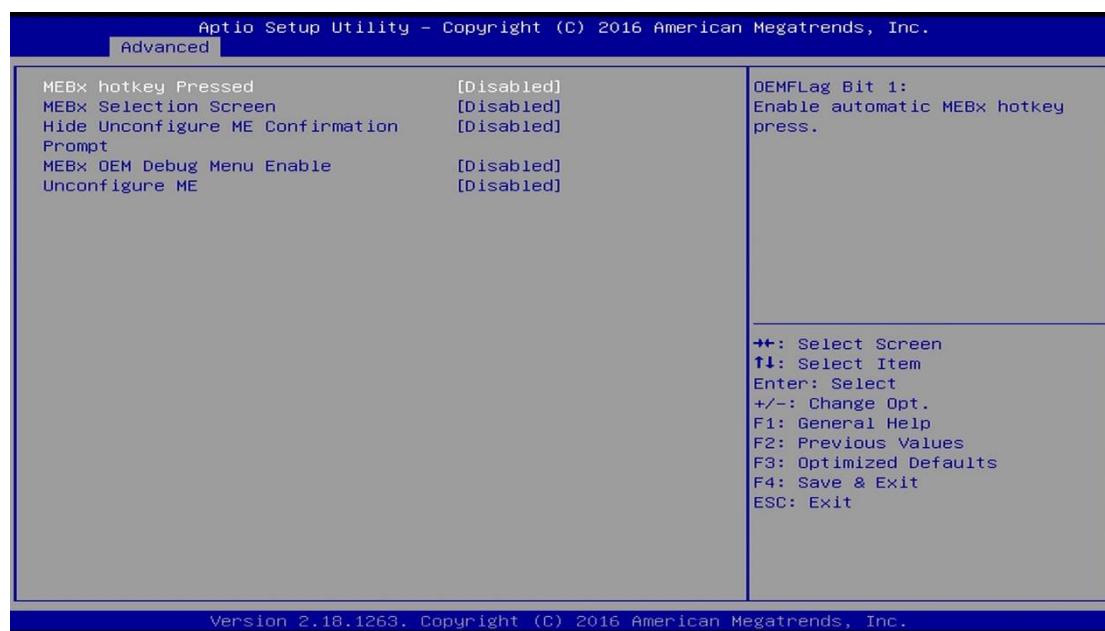

BIOS Setting	Description
MEBx hotkey Pressed	OEMFlag Bit 1: enables automatic MEBx hotkey press.
MEBx Selection Screen	OEMFlag Bit 2: enables MEBx selection screen with 2 options. <ul style="list-style-type: none"> Press 1 to enter ME configuration screens. Press 2 to initiate a remote connection. Note: Network access must be activated from MEBx Setup for this screen to be displayed.
Hide Unconfigure ME Confirmation Prompt	OEMFlag Bit 6: hides the unconfigure ME confirmation prompt when attempting ME unconfiguration.
MEBx OEM Debug Menu Enable	OEMFlag Bit 14: enables OEM debug menu in MEBx.
Unconfigure ME	OEMFlag Bit 15: Unconfigures ME with resetting MEBx password to default.

4.4.4.4. MEBx Resolution Settings

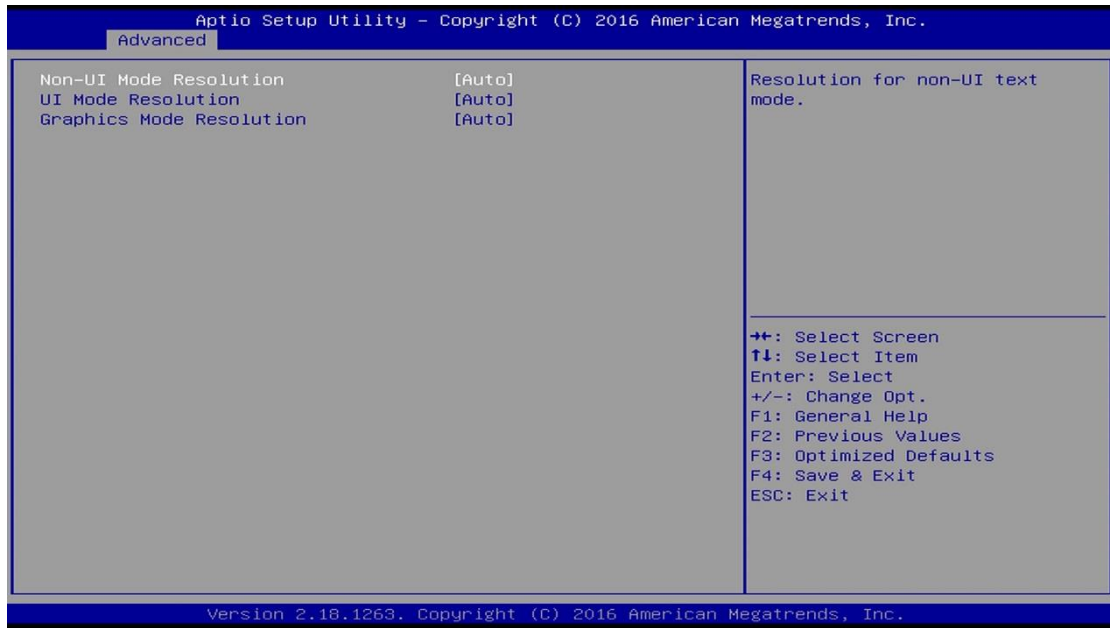

BIOS Setting	Description
Non-UI Mode Resloution	Sets resolution fro non-UI text mode.
UI Mode Resolution	Sets resolution for UI text mode.
Graphics Mode Resolution	Sets resolution for graphics mode.

4.4.5 PTT Configuration

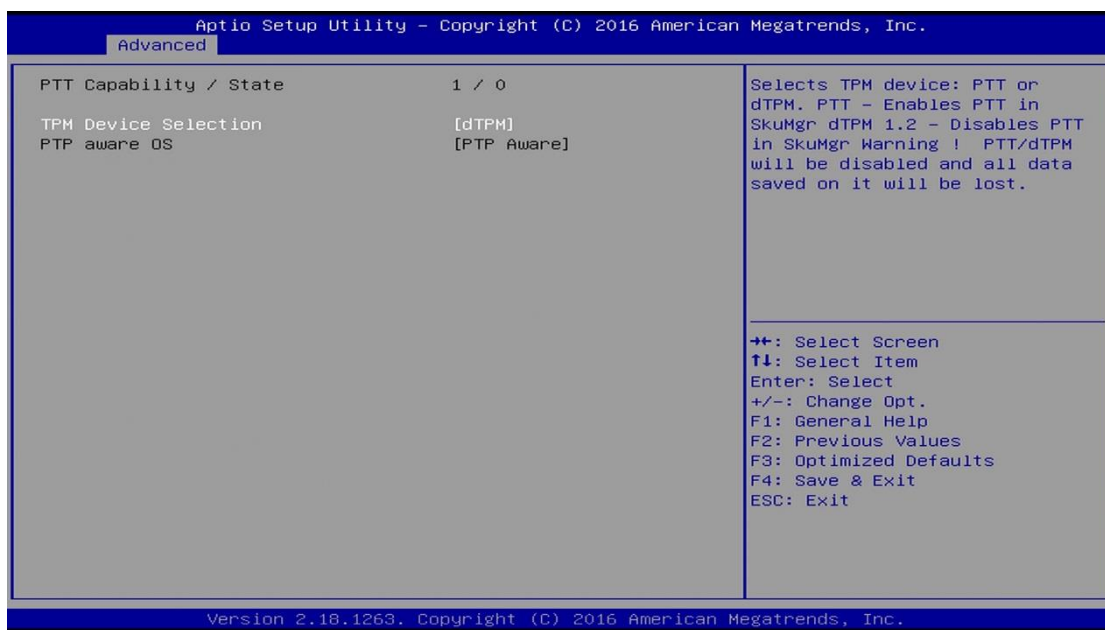

BIOS Setting	Description
TPM Device Selection	Selects TPM device: PTT or dTPM. <ul style="list-style-type: none"> • PTT enables PTT in SkuMgr. • dTPM 1.2 disables PTT in SkuMgr warning. PTT/dTPM will be disabled and all data saved on it will be lost.

4.4.6 ME Debug Configuration

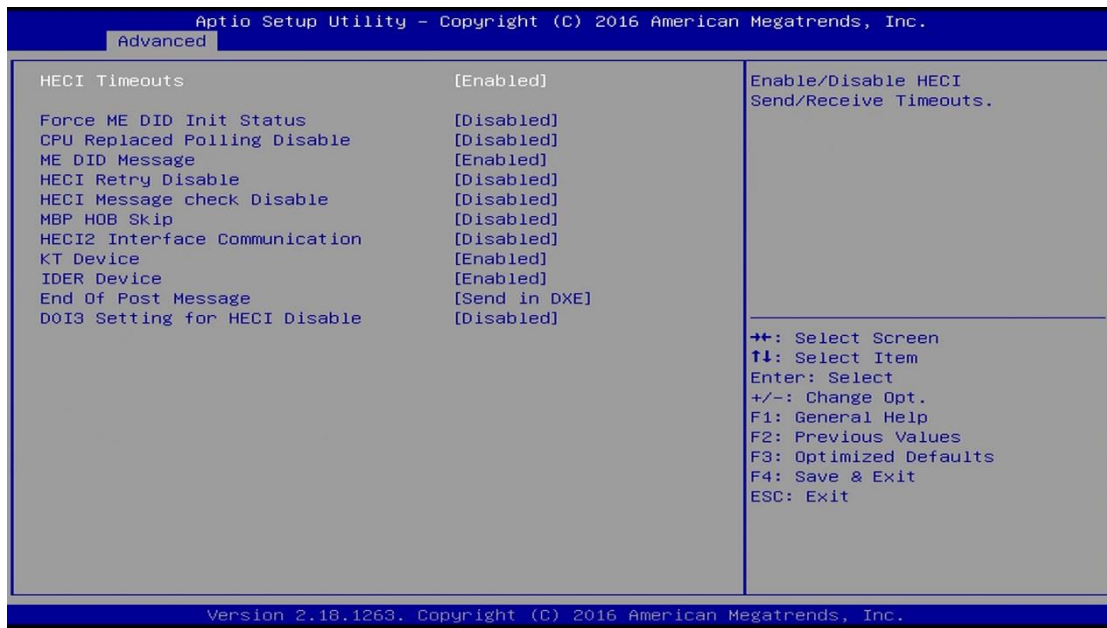

BIOS Setting	Description
HECI Timeouts	Enables / Disables HECI sending/receiving timeouts.
Force ME DID Init Status	Forces the DID initialization status value.
CPU Replaced Polling Disable	Disables CPU replacement polling loop.
ME DID Message	Enables / Disables ME DID message (disable will prevent the DID message from being sent).
HECI Retry Disable	Setting this option disables retry mechanism for all HECI APIs.
HECI Message Check Disable	Disables message check for BIOS boot path when sending messages.
MBP HDB Skip	Enables / Disables skip of MBP HDB.
HECI2 Interface Communicationn	Adds / Removes HECI2 device from PCI space.
KT Device	Enables / Disables KT device.
IDER Device	Enables / Disables IDER device.
End of Post Message	Enables / Disables end of Post message sent to ME.
DOI3 Setting for HECI Disable	Disables setting DOI3 bit for all HECI devices.

4.4.7 Trusted Computing

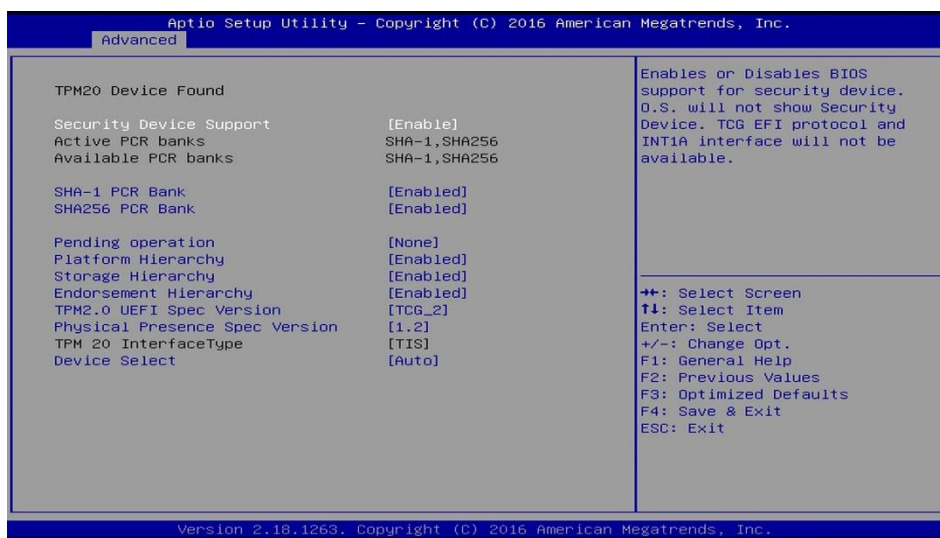

BIOS Setting	Description
Security Device Support	Enables / Disables BIOS support for security device. OS will not show security device. TCG EFI protocol and INT1A interface will not be available.
SHA-1 PCR Bank	Enables / Disables SHA-1 PCR Bank.
SHA256 PCR Bank	Enables / Disables SHA256 PCR Bank.
Pending operation	Schedule an operation for the security device. Note: Your computer will reboot during restart in order to change state of security device.
Platform Hierarchy	Enables / Disables platform hierarchy.
Storage Hierarchy	Enables / Disables storage hierarchy.
Endorsement Hierarchy	Enables / Disables endorsement hierarchy.
TPM2.0 UEFI Spec Version	Selects the supported TCG version based on your OS. <ul style="list-style-type: none"> • TCG_1_2: supports Windows 8 /10. • TCG_2: supports new TCG2 protocol and event format for Windows 10 or later.
Physical Presence Spec Version	Selects to show the PPI Spec Version (1.2 or 1.3) that the OS supports. Note: Some HCK tests might not support 1.3.
Device Select	<ul style="list-style-type: none"> • TPM 1.2 will restrict support to TPM 1.2 devices only. • TPM 2.0 will restrict support to TPM 2.0 devices only. • Auto will support both with the default being set to TPM 2.0 devices if not found, and TPM 1.2 device will be enumerated.

4.4.8 ACPI Settings

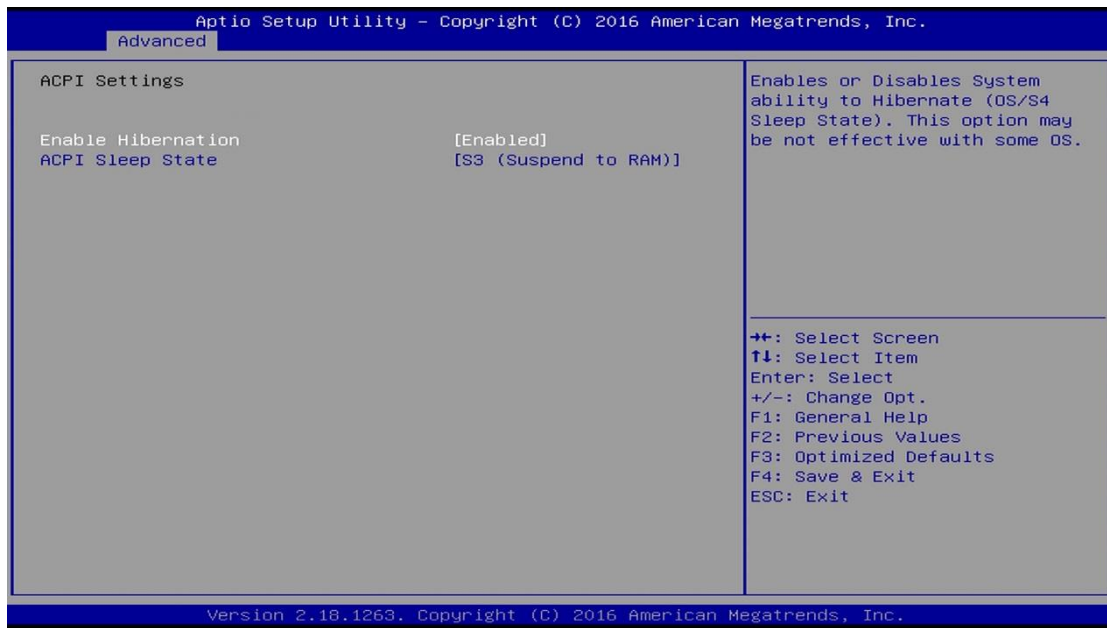

BIOS Setting	Description
Enable Hibernation	Enables / Disables the system ability to hibernate (OS/S4 Sleep State). This option may be not effective with some OS.
ACPI Sleep State	Selects an ACPI sleep state (Suspend Disabled or S3) where the system will enter when the Suspend button is pressed.

4.4.9 iSmart Controller

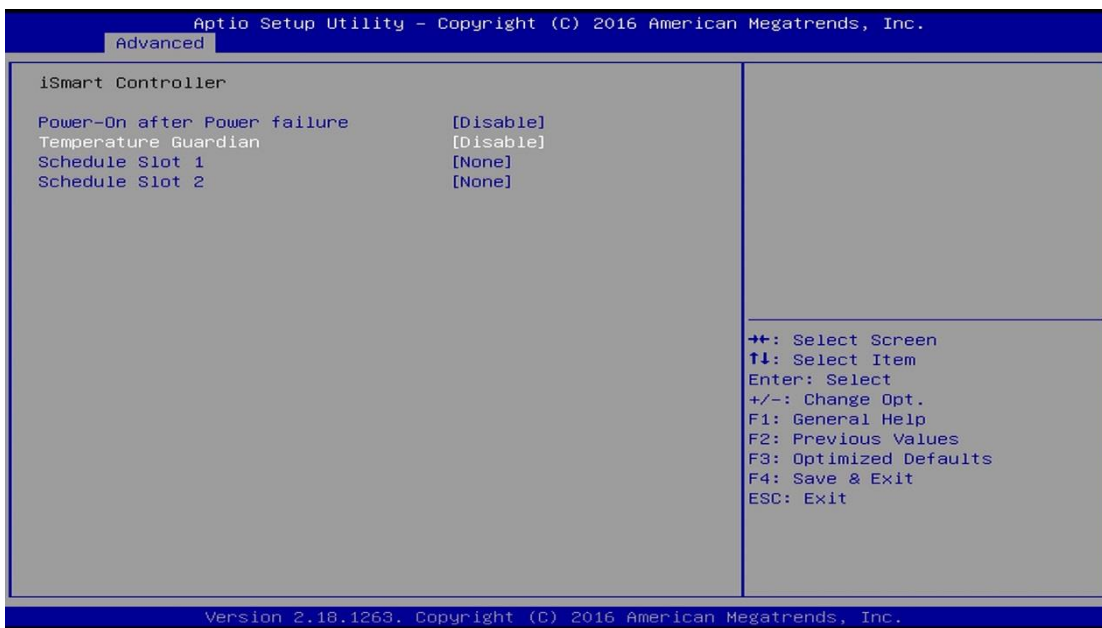

BIOS Setting	Description
Power-On after Power failure	Enables / Disables the system to be turned on automatically after a power failure.
Temperature Guardian	Generate the reset signal when system hands up on POST.
Schedule Slots	Sets up the hour / minute / day for the power-on schedule for the system. Options: None, Power On, Power On/Off

4.4.10 F81846 Super IO Configuration

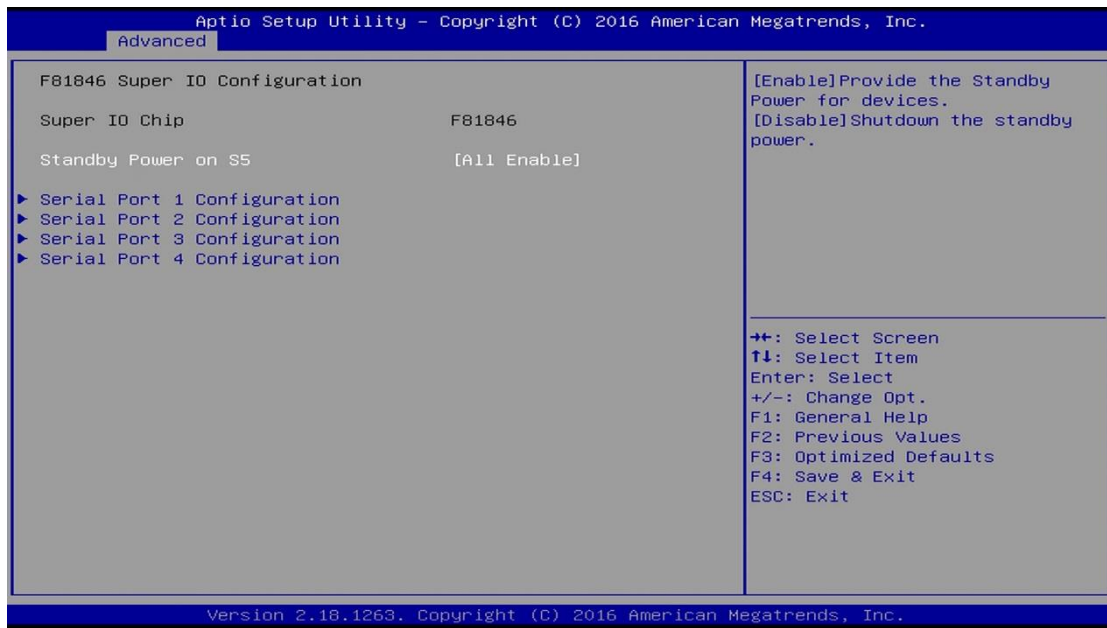

BIOS Setting	Description
Standby Power on S5	Enables / Disables to provide the standby power for devices. Options: All Enable / Enable Ethernet for WOL / All Disable
Serial Ports Configuration	Sets parameters of serial ports. Enables / Disables the serial port and select an optimal setting for the Super IO device.

4.4.10.1. Serial Port 1 Configuration

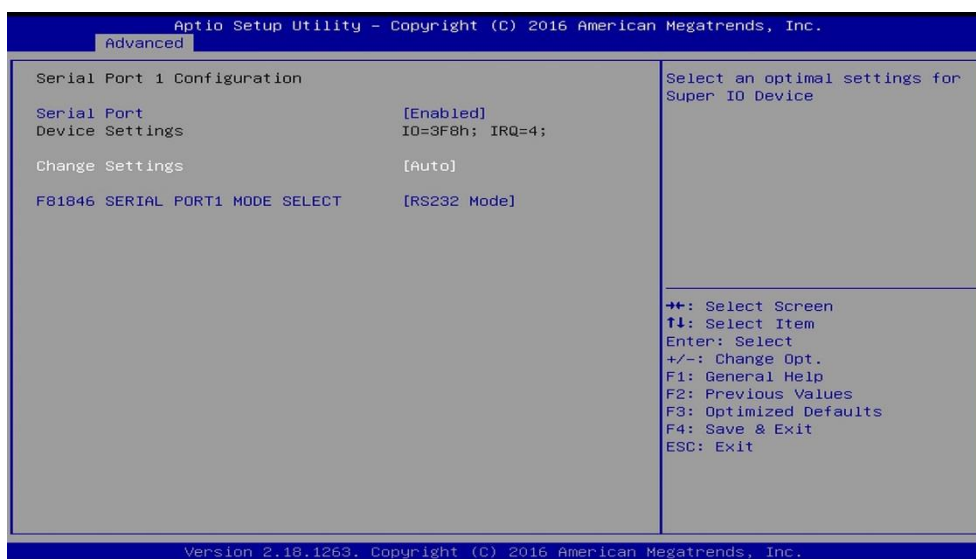

BIOS Setting	Description
Serial Port	Enables / Disables the serial port.
Change Settings	Selects an optimal settings for Super I/O device. Options: <ul style="list-style-type: none"> • Auto • IO = 3F8h; IRQ = 4 • IO = 3F8h; IRQ = 3, 4, 5, 6, 7, 9, 10, 11, 12 • IO = 2F8h; IRQ = 3, 4, 5, 6, 7, 9, 10, 11, 12 • IO = 3E8h; IRQ = 3, 4, 5, 6, 7, 9, 10, 11, 12 • IO = 2E8h; IRQ = 3, 4, 5, 6, 7, 9, 10, 11, 12
F81846 Serial Port 1 Mode Select	Changes the serial port mode to RS232/422/485.

4.4.11 Hardware Monitor

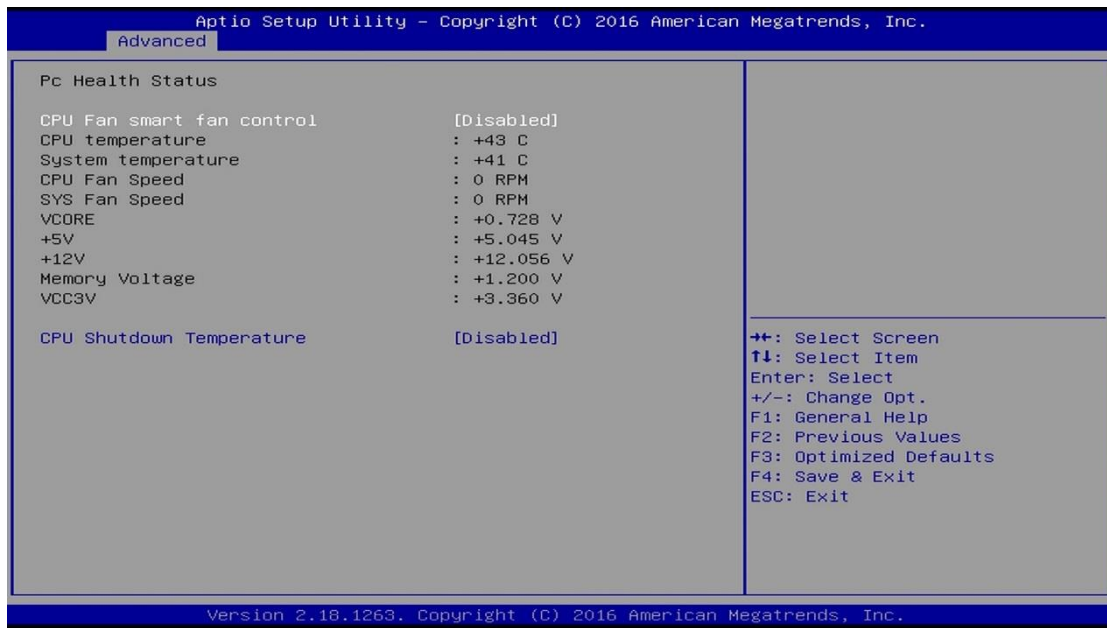

BIOS Setting	Description
CPU Fan smart fan control	Enables / Disables smart fan control.
Temperatures / Voltages	These fields are the parameters of the hardware monitoring function feature of the motherboard. The values are read-only values as monitored by the system and show the PC health status.
CPU Shutdown Temperature	Sets a threshold of temperature to shut down if CPU goes overheated. Options: Disabled, 70°C, 75°C, 80°C, 85°C, 90°C, 95 °C

4.4.12 CSM Configuration

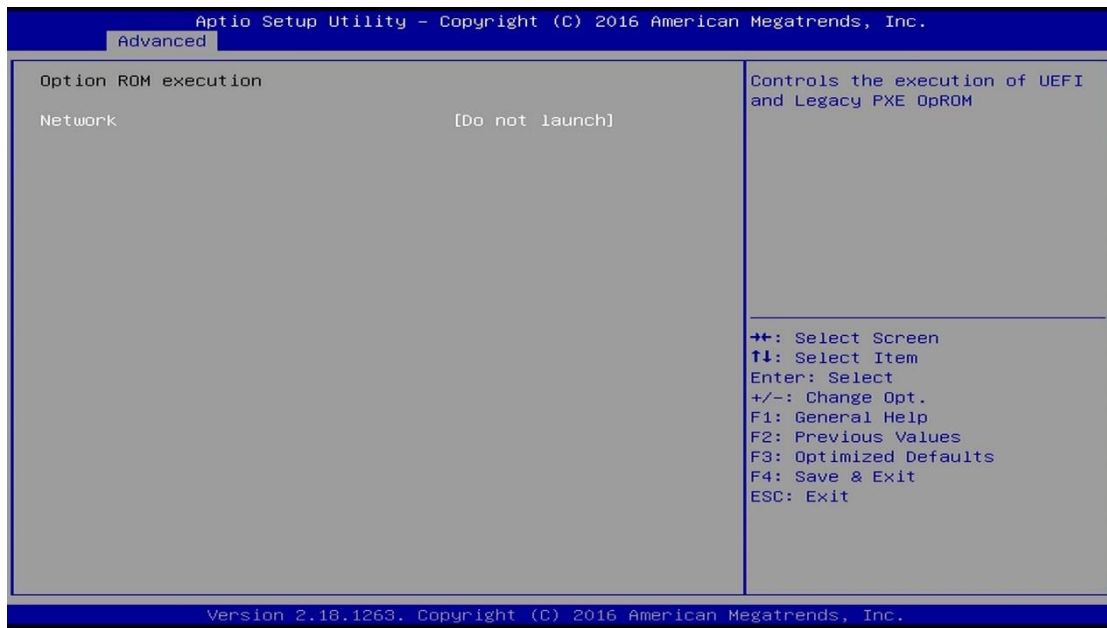

BIOS Setting	Description
Network	Controls the execution of UEFI and Legacy PXE OpROM.

4.4.13 USB Configuration

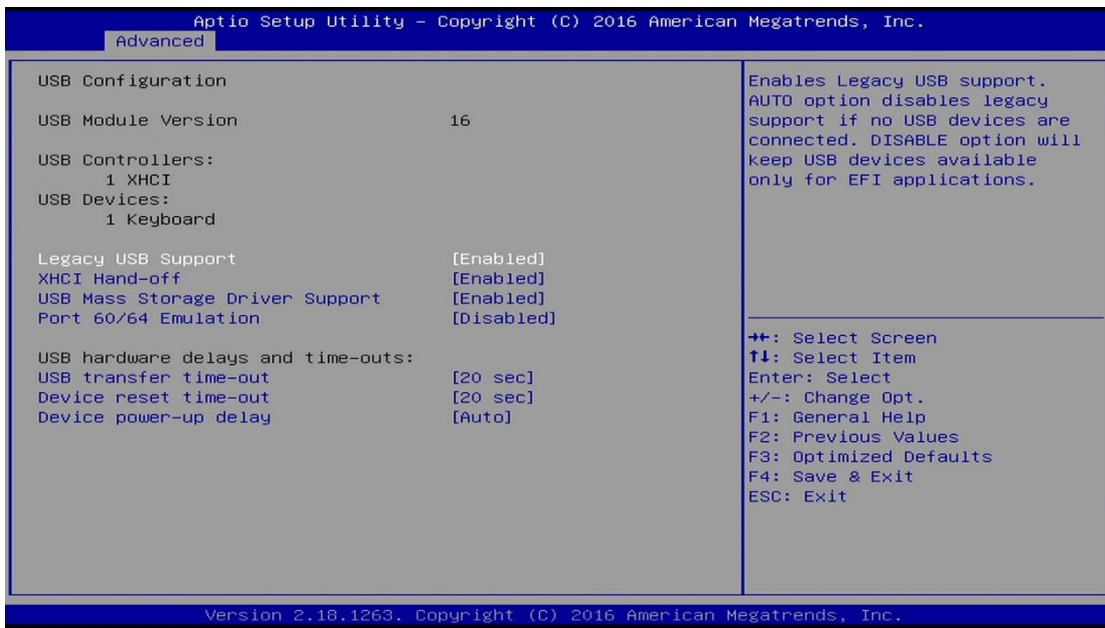

BIOS Setting	Description
Legacy USB Support	<ul style="list-style-type: none"> • Enabled enables Legacy USB support. • Auto disables legacy support if there is no USB device connected. • Disabled keeps USB devices available only for EFI applications.
XHCI Hand-off	This is a workaround for OSEs without XHCI hand-off support. The XHCI ownership change should be claimed by XHCI driver.
USB Mass Storage Driver Support	Enables / Disables the support for USB mass storage driver.
Port 60/64 Emulation	Enables / Disables the support for I/O port 60h / 64h emulation. This should be enabled for the complete USB keyboard legacy support for non-USB aware OSEs.
USB Transfer time-out	The time-out value (1, 5, 10, 20 secs) for Control, Bulk, and Interrupt transfers.
Device reset time-out	Gives seconds (10, 20, 30, 40 secs) to delay execution of Start Unit command to USB mass storage device.
Device power-up delay	The maximum time the device will take before it properly reports itself to the Host Controller. Auto uses default value for a Root port it is 100ms. But for a Hub port, the delay is taken from Hub descriptor.

4.5 Chipset Settings

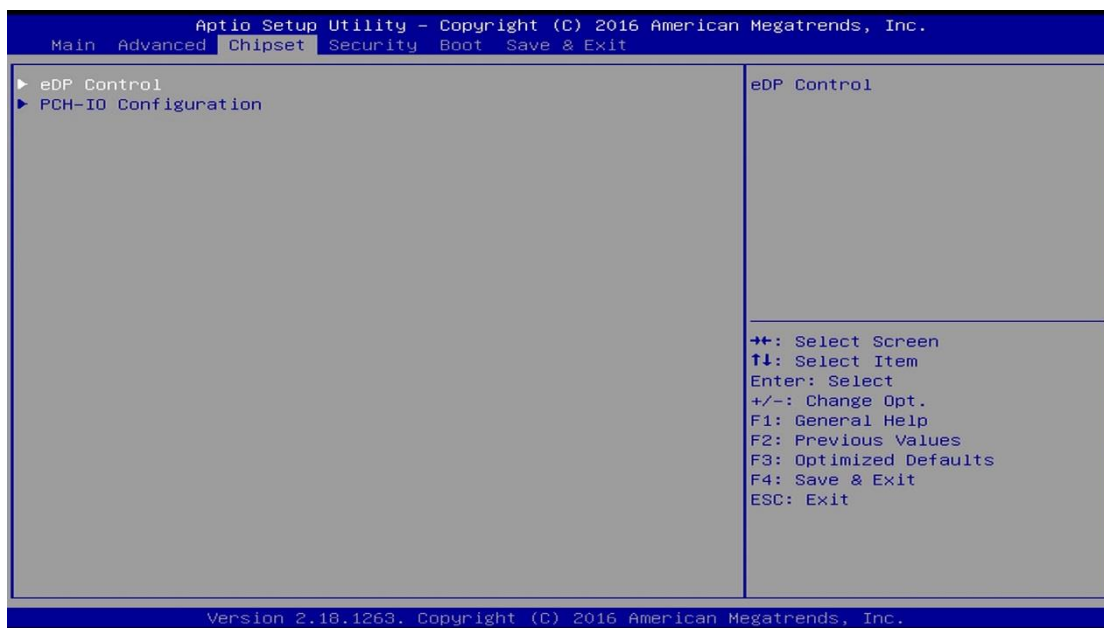

4.5.1 eDP Control

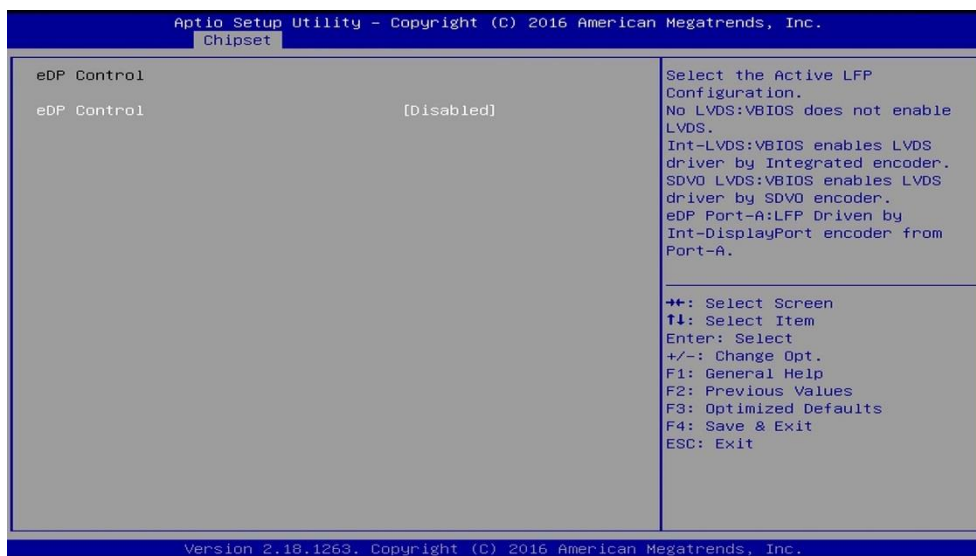

BIOS Setting	Description
eDP Control	<p>Selects or disables the Active LFP configuration.</p> <ul style="list-style-type: none"> • No LVDS: VBIOS does not enable LVDS. • Int-LVDS: VBIOS enables LVDS driver by Integrated encoder. • SDVD LVDS: VBIOS enables LVDS driver by SDVD encoder. • eDP Port-A: LFP driven by Int-DisplayPort encoder from Port-A.

4.5.2 PCH-IO Configuration

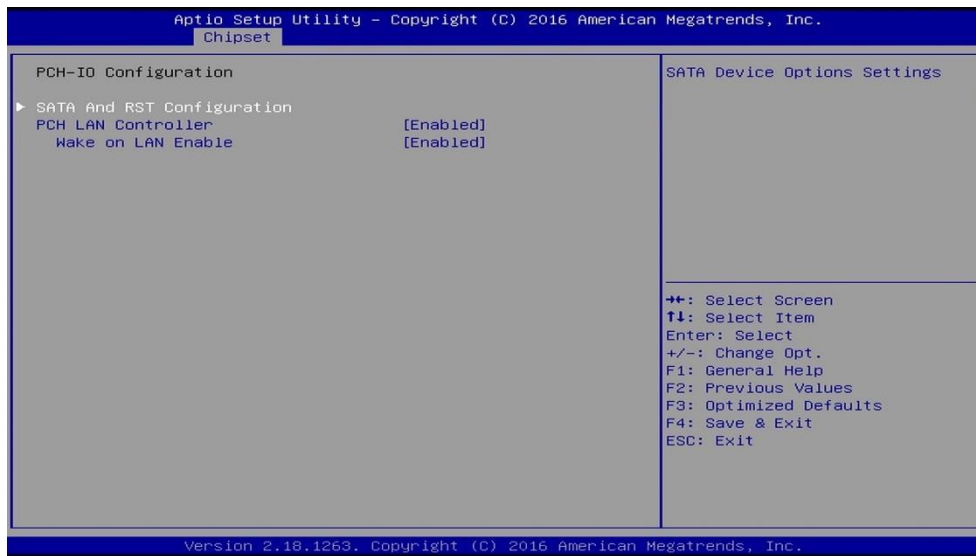

BIOS Setting	Description
SATA and RST Configuration	SATA device options and settings
PCH LAN Controller	Enables / Disables onboard NIC.
Wake on LAN Enable	Enables / Disables integrated LAN to wake the system.

4.5.2.1. SATA and RST Configuration

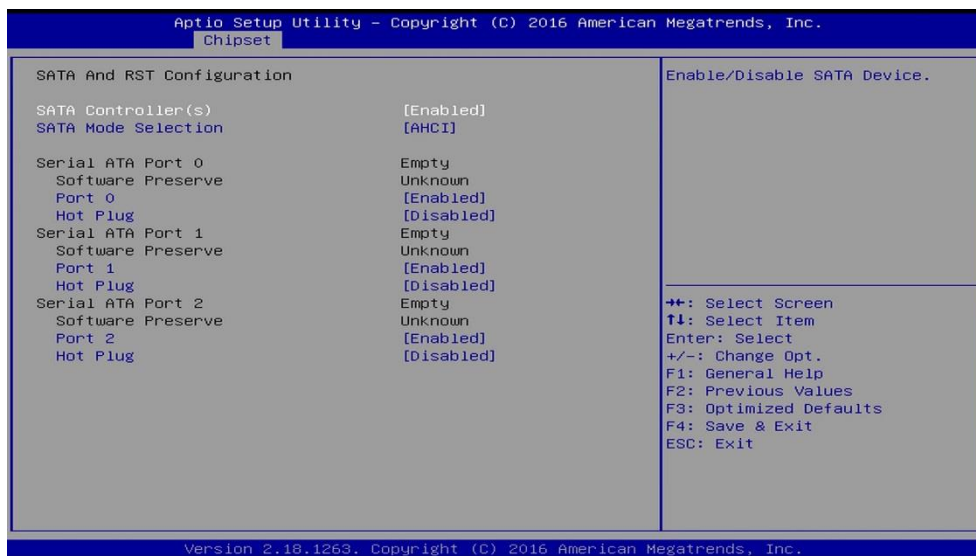

BIOS Setting	Description
SATA Controller(s)	Enables / Disables the Serial ATA.
SATA Mode Selection	Selects IDE or AHCI Mode.
Serial ATA Port 0~2	Enables / Disables Serial Port 0 ~ 2.
SATA Ports Hot Plug	Enables / Disables SATA Ports HotPlug.

4.6 Security Settings

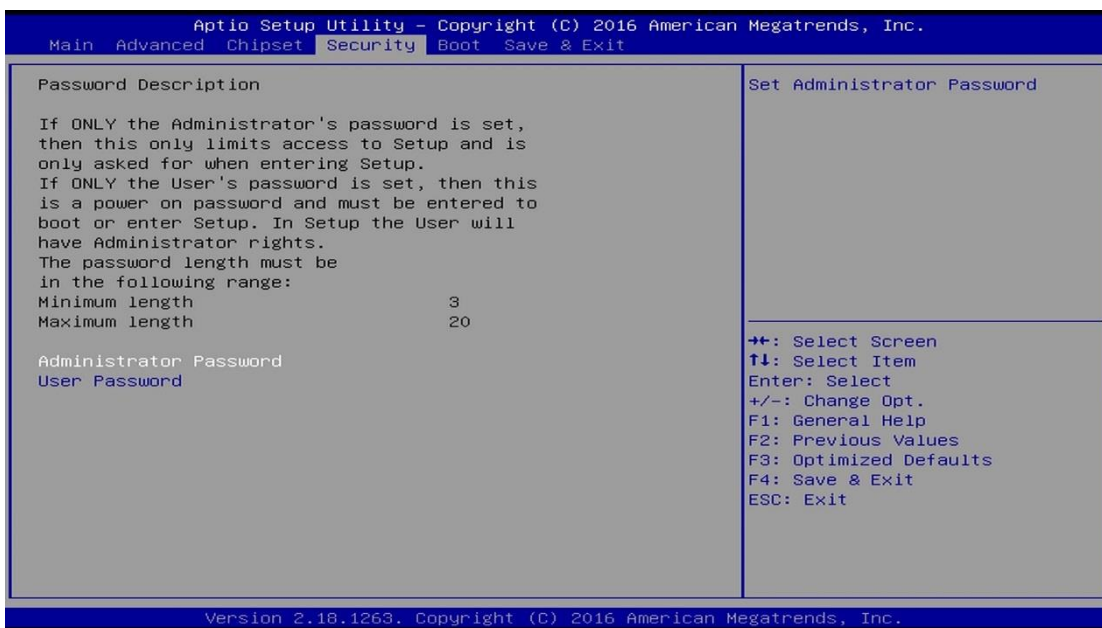

BIOS Setting	Description
Administrator Password	Sets an administrator password for the setup utility.
User Password	Sets a user password.

4.7 Boot Settings

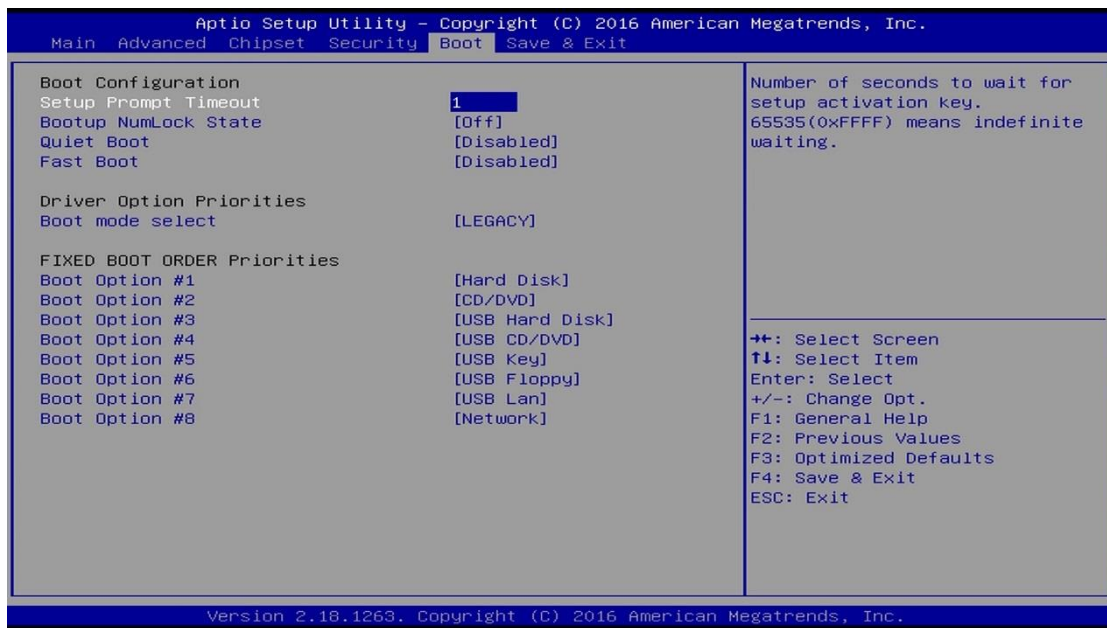

BIOS Setting	Description
Setup Prompt Timeout	Number of seconds to wait for setup activation key. 65535 (0xFFFF) means indefinite waiting.
Bootup NumLock State	Selects the keyboard NumLock state.
Quiet Boot	Enables / Disables Quiet Boot option.
Fast Boot	Enables / Disables boot with initialization of a minimal set of devices required to launch the active boot option. Has no effect for BBS boot options.
Boot mode select	Selects a Boot mode, Legacy / UEFI.
Boot Option Priorities	Sets the system boot order priorities for hard disk, CD/DVD, USB, Network.

4.8 Save & Exit Settings



BIOS Setting	Description
Save Changes and Exit	Exits system setup after saving the changes.
Discard Changes and Exit	Exits system setup without saving any changes.
Save Changes and Reset	Resets the system after saving the changes.
Discard Changes and Reset	Resets system setup without saving any changes.
Save Changes	Saves changes done so far to any of the setup options.
Discard Changes	Discards changes done so far to any of the setup options.
Restore Defaults	Restores / Loads defaults values for all the setup options.
Save as User Defaults	Saves the changes done so far as User Defaults.
Restore User Defaults	Restores the user defaults to all the setup options.

Appendix

This section provides the mapping addresses of peripheral devices and the sample code of watchdog timer configuration.

- I/O Port Address Map
- Interrupt Request Lines (IRQ)
- Digital I/O Sample Code
- Watchdog Timer Configuration

A. I/O Port Address Map

Each peripheral device in the system is assigned a set of I/O port addresses which also becomes the identity of the device. The following table lists the I/O port addresses used.

Address	Device Description
0x00000020-0x00000021	Programmable interrupt controller
0x00000024-0x00000025	Programmable interrupt controller
0x00000028-0x00000029	Programmable interrupt controller
0x0000002C-0x0000002D	Programmable interrupt controller
0x00000030-0x00000031	Programmable interrupt controller
0x00000034-0x00000035	Programmable interrupt controller
0x00000038-0x00000039	Programmable interrupt controller
0x0000003C-0x0000003D	Programmable interrupt controller
0x000000A0-0x000000A1	Programmable interrupt controller
0x000000A4-0x000000A5	Programmable interrupt controller
0x000000A8-0x000000A9	Programmable interrupt controller
0x000000AC-0x000000AD	Programmable interrupt controller
0x000000B0-0x000000B1	Programmable interrupt controller
0x000000B4-0x000000B5	Programmable interrupt controller
0x000000B8-0x000000B9	Programmable interrupt controller
0x000000BC-0x000000BD	Programmable interrupt controller
0x000004D0-0x000004D1	Programmable interrupt controller
0x00000A00-0x00000A0F	Motherboard resources
0x00000A10-0x00000A1F	Motherboard resources
0x00000A10-0x00000A1F	Motherboard resources
0x0000002E-0x0000002F	Motherboard resources
0x0000004E-0x0000004F	Motherboard resources
0x00000061-0x00000061	Motherboard resources
0x00000063-0x00000063	Motherboard resources
0x00000065-0x00000065	Motherboard resources
0x00000067-0x00000067	Motherboard resources
0x00000070-0x00000070	Motherboard resources
0x00000070-0x00000070	System CMOS/real time clock

Address	Device Description
0x00000080-0x00000080	Motherboard resources
0x00000092-0x00000092	Motherboard resources
0x000000B2-0x000000B3	Motherboard resources
0x00000680-0x0000069F	Motherboard resources
0x0000FFFF-0x0000FFFF	Motherboard resources
0x0000FFFF-0x0000FFFF	Motherboard resources
0x0000FFFF-0x0000FFFF	Motherboard resources
0x00001800-0x000018FE	Motherboard resources
0x0000164E-0x0000164F	Motherboard resources
0x00001854-0x00001857	Motherboard resources
0x000003F8-0x000003FF	Communications Port (COM1)
0x000002F8-0x000002FF	Communications Port (COM2)
0x000003E8-0x000003EF	Communications Port (COM3)
0x000002E8-0x000002EF	Communications Port (COM4)
0x00000000-0x00000CF7	PCI Express Root Complex
0x00000D00-0x0000FFFF	PCI Express Root Complex
0x00000040-0x00000043	System timer
0x00000050-0x00000053	System timer
0x0000E000-0x0000EFFF	Mobile 6th/7th Generation Intel(R) Processor Family I/O PCI Express Root Port #11 - 9D1A
0x0000F040-0x0000F05F	Mobile 6th/7th Generation Intel(R) Processor Family I/O SMBUS - 9D23
0x0000FF00-0x0000FFFE	Motherboard resources
0x00000060-0x00000060	Standard PS/2 Keyboard
0x00000064-0x00000064	Standard PS/2 Keyboard
0x0000F090-0x0000F097	Standard SATA AHCI Controller
0x0000F080-0x0000F083	Standard SATA AHCI Controller
0x0000F060-0x0000F07F	Standard SATA AHCI Controller
0x0000F000-0x0000F03F	Intel(R) HD Graphics 620
0x000003B0-0x000003BB	Intel(R) HD Graphics 620
0x000003C0-0x000003DF	Intel(R) HD Graphics 620

B. Interrupt Request Lines (IRQ)

Peripheral devices use interrupt request lines to notify CPU for the service required. The following table shows the IRQ used by the devices on board.

Level	Function
IRQ 0	System timer
IRQ 1	Standard PS/2 Keyboard
IRQ 3	Communications Port (COM2)
IRQ 4	Communications Port (COM1)
IRQ 5	Communications Port (COM3)
IRQ 7	Communications Port (COM4)
IRQ 8	System CMOS/real time clock
IRQ 11	Mobile 6th/7th Generation Intel(R) Processor Family I/O SMBUS - 9D23
IRQ 11	Mobile 6th/7th Generation Intel(R) Processor Family I/O Thermal subsystem - 9D31
IRQ 12	Microsoft PS/2 Mouse
IRQ 14	Motherboard resources
IRQ 16	High Definition Audio Controller
IRQ 54 ~ IRQ 204	Microsoft ACPI-Compliant System
IRQ 256 ~ IRQ 511	Microsoft ACPI-Compliant System
IRQ 4294967285	Intel(R) Management Engine Interface
IRQ 4294967286	Intel(R) I211 Gigabit Network Connection
IRQ 4294967287	Intel(R) I211 Gigabit Network Connection
IRQ 4294967288	Intel(R) I211 Gigabit Network Connection
IRQ 4294967289	Intel(R) I211 Gigabit Network Connection
IRQ 4294967290	Intel(R) USB 3.0 eXtensible Host Controller - 1.0 (Microsoft)
IRQ 4294967291	Intel(R) HD Graphics 620
IRQ 4294967292	Intel(R) Ethernet Connection I219-V
IRQ 4294967293	Standard SATA AHCI Controller
IRQ 4294967294	Mobile 6th/7th Generation Intel(R) Processor Family I/O PCI Express Root Port #11 - 9D1A

C. Digital I/O Sample Code

1. DIO Sample Code: The file F81846.cpp

```
//=====
=====
//
// THIS CODE AND INFORMATION IS PROVIDED "AS IS" WITHOUT WARRANTY OF ANY
// KIND, EITHER EXPRESSED OR IMPLIED, INCLUDING BUT NOT LIMITED TO THE
// IMPLIED WARRANTIES OF MERCHANTABILITY AND/OR FITNESS FOR A
// PARTICULAR
// PURPOSE.
//
//=====
=====
#include "F81846.H"
#include <dos.h>
//=====
=====
unsigned int F81846_BASE;
void Unlock_F81846 (void);
void Lock_F81846 (void);
//=====
=====
unsigned int Init_F81846(void)
{
    unsigned int result; //
    unsigned char ucDid;

    F81846_BASE = 0x4E;
    result = F81846_BASE;

    ucDid = Get_F81846_Reg(0x20);
    if ((ucDid == 0x07) || (ucDid == 0x10) || (ucDid == 0x15)) //Fintek
81865/81846/81846/81946/81846
    {    goto Init_Finish;}

    F81846_BASE = 0x2E;
    result = F81846_BASE;

    ucDid = Get_F81846_Reg(0x20);
    if ((ucDid == 0x07) || (ucDid == 0x10) || (ucDid == 0x15)) //Fintek
81865/81846/81846/81946/81846
    {    goto Init_Finish;}

    F81846_BASE = 0x00;
    result = F81846_BASE;

Init_Finish:
    return (result);
}
//=====
=====
```

```

void Unlock_F81846 (void)
{
    outportb(F81846_INDEX_PORT, F81846_UNLOCK);
    outportb(F81846_INDEX_PORT, F81846_UNLOCK);
}
//=====================================================
=====
void Lock_F81846 (void)
{
    outportb(F81846_INDEX_PORT, F81846_LOCK);
}
//=====================================================
=====
void Set_F81846_LD( unsigned char LD)
{
    Unlock_F81846();
    outportb(F81846_INDEX_PORT, F81846_REG_LD);
    outportb(F81846_DATA_PORT, LD);
    Lock_F81846();
}
//=====================================================
=====
void Set_F81846_Reg( unsigned char REG, unsigned char DATA)
{
    Unlock_F81846();
    outportb(F81846_INDEX_PORT, REG);
    outportb(F81846_DATA_PORT, DATA);
    Lock_F81846();
}
//=====================================================
=====
unsigned char Get_F81846_Reg(unsigned char REG)
{
    unsigned char Result;
    Unlock_F81846();
    outportb(F81846_INDEX_PORT, REG);
    Result = inportb(F81846_DATA_PORT);
    Lock_F81846();
    return Result;
}
//=====================================================
=====

```

2. DIO Sample Code: The file F81846.h

```
//=====
//=====
//
// THIS CODE AND INFORMATION IS PROVIDED "AS IS" WITHOUT WARRANTY OF ANY
// KIND, EITHER EXPRESSED OR IMPLIED, INCLUDING BUT NOT LIMITED TO THE
// IMPLIED WARRANTIES OF MERCHANTABILITY AND/OR FITNESS FOR A
// PARTICULAR
// PURPOSE.
//
//=====
//=====
#ifndef __F81846_H
#define __F81846_H          1
//=====
//=====
#define F81846_INDEX_PORT      (F81846_BASE)
#define F81846_DATA_PORT      (F81846_BASE+1)
//=====
//=====
#define F81846_REG_LD          0x07
//=====
//=====
#define F81846_UNLOCK          0x87
#define F81846_LOCK            0xAA
//=====
//=====
unsigned int Init_F81846(void);
void Set_F81846_LD( unsigned char);
void Set_F81846_Reg( unsigned char, unsigned char);
unsigned char Get_F81846_Reg( unsigned char);
//=====
//=====
#endif    //__F81846_H
```

3. DIO Sample Code: The file MAIN.CPP

```
//-----
//
// THIS CODE AND INFORMATION IS PROVIDED "AS IS" WITHOUT WARRANTY OF ANY
// KIND, EITHER EXPRESSED OR IMPLIED, INCLUDING BUT NOT LIMITED TO THE
// IMPLIED WARRANTIES OF MERCHANTABILITY AND/OR FITNESS FOR A
// PARTICULAR
// PURPOSE.
//
//-----
#include <dos.h>
#include <conio.h>
#include <stdio.h>
#include <stdlib.h>
#include "F81846.H"
//-----
void ClrKbBuf(void);
int main (int argc, char *argv[]);
//-----
int main (int argc, char *argv[])
{
    unsigned char result;
    char SIO;

    SIO = Init_F81846();
    if (SIO == 0)
    {
        printf("Can not detect Fintek F81846, program abort.\n");
        return(1);
    }

    Set_F81846_LD(0x06);
    //switch to logic device 6

    result = ((Get_F81846_Reg(0xE2)) & 0x04) ? 0x01 : 0x00;    //result = 0x00 GPI is
    Low / result = 0x01 GPI is High

    return (result);
}
```

D. Watchdog Timer Configuration

The Watchdog Timer (WDT) is used to generate a variety of output signals after a user programmable count. The WDT is suitable for the use in the prevention of system lock-up, such as when software becomes trapped in a deadlock. Under these sorts of circumstances, the timer will count to zero and the selected outputs will be driven.

Under normal circumstance, you will need to restart the WDT at regular intervals before the timer counts to zero.

Sample Code

```
//-----  
//  
// THIS CODE AND INFORMATION IS PROVIDED "AS IS" WITHOUT WARRANTY OF ANY  
// KIND, EITHER EXPRESSED OR IMPLIED, INCLUDING BUT NOT LIMITED TO THE  
// IMPLIED WARRANTIES OF MERCHANTABILITY AND/OR FITNESS FOR A  
// PARTICULAR  
// PURPOSE.  
//  
//-----  
#include <dos.h>  
#include <conio.h>  
#include <stdio.h>  
#include <stdlib.h>  
#include "F81846.H"  
//-----  
int main (int argc, char *argv[]); void EnableWDT(int);  
void DisableWDT(void);  
//-----  
int main (int argc, char *argv[])  
{  
    unsigned char bBuf;  
    unsigned char bTime;  
    char **endptr;  
  
    char SIO;  
    printf("Fintek 81846 watch dog program\n");  
    SIO = Init_F81846();  
    if (SIO == 0)  
    {  
        printf("Can not detect Fintek 81846, program abort.\n");  
        return(1);  
    }/if (SIO == 0)  
  
    if (argc != 2)  
    {  
        printf(" Parameter incorrect!!\n");  
        return (1);  
    }  
}
```

```

bTime = strtol (argv[1], endptr, 10);
printf("System will reset after %d seconds\n", bTime);

if (bTime)
{   EnableWDT(bTime); }
else
{   DisableWDT(); }
return 0;
}
//-----
void EnableWDT(int interval)
{
    unsigned char bBuf;

    bBuf = Get_F81846_Reg(0x2B);
    bBuf &= (~0x20);
    Set_F81846_Reg(0x2B, bBuf);           //Enable WDTO

    Set_F81846_LD(0x07);                 //switch to logic device 7
    Set_F81846_Reg(0x30, 0x01);         //enable timer

    bBuf = Get_F81846_Reg(0xF5);
    bBuf &= (~0x0F);
    bBuf |= 0x52;
    Set_F81846_Reg(0xF5, bBuf);         //count mode is second
    Set_F81846_Reg(0xF6, interval);     //set timer
    bBuf = Get_F81846_Reg(0xFA);
    bBuf |= 0x01;
    Set_F81846_Reg(0xFA, bBuf);         //enable WDTO output

    bBuf = Get_F81846_Reg(0xF5);
    bBuf |= 0x20;
    Set_F81846_Reg(0xF5, bBuf);         //start counting
}
//-----
void DisableWDT(void)
{
    unsigned char bBuf;
    Set_F81846_LD(0x07);                 //switch to logic device 7
    bBuf = Get_F81846_Reg(0xFA);
    bBuf &= ~0x01;
    Set_F81846_Reg(0xFA, bBuf);         //disable WDTO output

    bBuf = Get_F81846_Reg(0xF5);
    bBuf &= ~0x20;
    bBuf |= 0x40;
    Set_F81846_Reg(0xF5, bBuf);         //disable WDT
}
//-----

```

```
//-----  
//  
// THIS CODE AND INFORMATION IS PROVIDED "AS IS" WITHOUT WARRANTY OF ANY  
// KIND, EITHER EXPRESSED OR IMPLIED, INCLUDING BUT NOT LIMITED TO THE  
// IMPLIED WARRANTIES OF MERCHANTABILITY AND/OR FITNESS FOR A  
// PARTICULAR  
// PURPOSE.  
//  
//-----  
#include "F81846.H"  
#include <dos.h>  
//-----  
unsigned int F81846_BASE; void Unlock_F81846 (void); void Lock_F81846 (void);  
//-----  
unsigned int Init_F81846(void)  
{  
    unsigned int result;  
    unsigned char ucDid;  
  
    F81846_BASE = 0x4E;  
    result = F81846_BASE;  
  
    ucDid = Get_F81846_Reg(0x20);  
    if (ucDid == 0x07) //Fintek 81846  
    {    goto Init_Finish; }  
  
    F81846_BASE = 0x2E;  
    result = F81846_BASE;  
  
    ucDid = Get_F81846_Reg(0x20);  
    if (ucDid == 0x07) //Fintek 81846  
    {    goto Init_Finish; }  
  
    F81846_BASE = 0x00;  
    result = F81846_BASE;  
  
Init_Finish:  
    return (result);  
}  
//-----  
void Unlock_F81846 (void)  
{  
    outportb(F81846_INDEX_PORT, F81846_UNLOCK);  
    outportb(F81846_INDEX_PORT, F81846_UNLOCK);  
}  
//-----  
void Lock_F81846 (void)  
{  
    outportb(F81846_INDEX_PORT, F81846_LOCK);  
}  
//-----  
void Set_F81846_LD( unsigned char LD)  
{  
    Unlock_F81846();
```

```

        outportb(F81846_INDEX_PORT, F81846_REG_LD);
        outportb(F81846_DATA_PORT, LD); Lock_F81846();
    }
//-----
void Set_F81846_Reg( unsigned char REG, unsigned char DATA)
{
    Unlock_F81846();
    outportb(F81846_INDEX_PORT, REG);
    outportb(F81846_DATA_PORT, DATA);
    Lock_F81846();
}
//-----
unsigned char Get_F81846_Reg(unsigned char REG)
{
    unsigned char Result;
    Unlock_F81846();
    outportb(F81846_INDEX_PORT, REG);
    Result = inportb(F81846_DATA_PORT);
    Lock_F81846();
    return Result;
}
//-----

//-----
//
// THIS CODE AND INFORMATION IS PROVIDED "AS IS" WITHOUT WARRANTY OF ANY
// KIND, EITHER EXPRESSED OR IMPLIED, INCLUDING BUT NOT LIMITED TO THE
// IMPLIED WARRANTIES OF MERCHANTABILITY AND/OR FITNESS FOR A
// PARTICULAR
// PURPOSE.
//
//-----
#ifndef    F81846_H
#define    F81846_H    1
//-----
#define    F81846_INDEX_PORT    (F81846_BASE)
#define    F81846_DATA_PORT    (F81846_BASE+1)
//-----
#define    F81846_REG_LD    0x07
//-----
#define    F81846_UNLOCK    0x87
#define    F81846_LOCK    0xAA
//-----
unsigned int Init_F81846(void);
void Set_F81846_LD( unsigned char);
void Set_F81846_Reg( unsigned char, unsigned char); unsigned char
Get_F81846_Reg( unsigned char);
//-----
#endif //    F81846_H

```