

**ARD-042-N**  
**All-in-One Bar-Type**  
**Digital Signage Display**

**User's Manual**

Version 1.0  
(Dec. 2018)



## **Copyright**

© 2018 IBASE Technology, Inc. All rights reserved.

No part of this publication may be reproduced, copied, stored in a retrieval system, translated into any language or transmitted in any form or by any means, electronic, mechanical, photocopying, or otherwise, without the prior written consent of IBASE Technology, Inc. (hereinafter referred to as "IBASE").

## **Disclaimer**

IBASE reserves the right to make changes and improvements to the products described in this document without prior notice. Every effort has been made to ensure the information in the document is correct; however, IBASE does not guarantee this document is error-free. IBASE assumes no liability for incidental or consequential damages arising from misapplication or inability to use the product or the information contained herein, nor for any infringements of rights of third parties, which may result from its use.

## **Trademarks**

All the trademarks, registrations and brands mentioned herein are used for identification purposes only and may be trademarks and/or registered trademarks of their respective owners.

## Compliance

### CE

This product has passed CE tests for environmental specifications and limits. This product is in accordance with the directives of the Union European (EU). If users modify and/or install other devices in this equipment, the CE conformity declaration may no longer apply.

### FCC

This product has been tested and found to comply with the limits for a Class B device, pursuant to Part 15 of the FCC Rules. These limits are designed to provide reasonable protection against harmful interference in a residential installation. This equipment generates, uses and can radiate radio frequency energy and, if not installed and used in accordance with manufacturer's instructions, may cause harmful interference to radio communications.

### WEEE



This product must not be disposed of as normal household waste, in accordance with the EU directive of for waste electrical and electronic equipment (WEEE - 2012/19/EU). Instead, it should be disposed of by returning it to a municipal recycling collection point. Check local regulations for disposal of electronic products.

### Green IBASE



This product is compliant with the current RoHS restrictions and prohibits use of the following substances in concentrations exceeding 0.1% by weight (1000 ppm) except for cadmium, limited to 0.01% by weight (100 ppm).

- Lead (Pb)
- Mercury (Hg)
- Cadmium (Cd)
- Hexavalent chromium (Cr6+)
- Polybrominated biphenyls (PBB)
- Polybrominated diphenyl ether (PBDE)

## Important Safety Information

Carefully read the precautions before using the device.

### Environmental conditions:

- Put the device horizontally on a stable and solid surface.
- Leave plenty of space around the device and do not block the ventilation openings. NEVER DROP OR INSERT ANY OBJECTS OF ANY KIND INTO THE VENTILATION OPENINGS.
- Use this product in environments with ambient temperatures between 0°C and 40°C.
- DO NOT LEAVE THIS DEVICE IN AN ENVIRONMENT WHERE THE STORAGE TEMPERATURE MAY GO BELOW -20°C OR ABOVE 80°C. This could damage the device. The device must be used in a controlled environment.

### Care during use:

- Before cleaning the device, turn it off and unplug all cables such as power in case a small amount of electrical current may still flow.
- Use neutral cleaning agents or diluted alcohol to clean the device chassis with a cloth. Then wipe the chassis with a dry cloth.
- Vacuum dust and particles from the vents by using a computer vacuum cleaner.



## WARNING

### Attention during use:

- Sharp-pointed articles are prohibited to the panel.
- Do not use this product near water.
- Do not spill water or any other liquids on your device.
- Do not place heavy objects on the top of the device.
- Operate this device from the type of power indicated on the marking label. If you are not sure of the type of power available, consult your distributor or local power company.
- Do not walk on the power cord or allow anything to rest on it.
- If you use an extension cord, make sure that the total ampere rating of the product plugged into the extension cord does not exceed its limits.

### Avoid Disassembly

Do not disassemble, repair or make any modification to the device. Doing so could generate hazards and cause damage to the device, even bodily injury or property damage, and will void any warranty.



## CAUTION

There is a danger of explosion if internal lithium-ion battery is replaced by an incorrect type. Replace only with the same or equivalent type recommended by the manufacturer. Dispose of used batteries by observing local regulations.

## Warranty Policy

- **IBASE standard products:**

24-month (2-year) warranty from the date of shipment. If the date of shipment cannot be ascertained, the product serial numbers can be used to determine the approximate shipping date.
- **3<sup>rd</sup>-party parts:**

12-month (1-year) warranty from delivery for the 3<sup>rd</sup>-party parts that are not manufactured by IBASE, such as CPU, memory, HDD, power adapter, panel and touchscreen.
- \* PRODUCTS, HOWEVER, THAT FAILS DUE TO MISUSE, ACCIDENT, IMPROPER INSTALLATION OR UNAUTHORIZED REPAIR SHALL BE TREATED AS OUT OF WARRANTY AND CUSTOMERS SHALL BE BILLED FOR REPAIR AND SHIPPING CHARGES.

## Technical Support & Services

1. Visit the IBASE website at [www.ibase.com.tw](http://www.ibase.com.tw) to find the latest information about the product.
2. If you encounter any technical problems and require assistance from your distributor or sales representative, please prepare and send the following information:
  - Product model name
  - Product serial number
  - Detailed description of the problem
  - The error messages in text or in screenshots if there is any
  - The arrangement of the peripherals
  - Software in use (such as OS and application software, including the version numbers)
3. If repair service is required, please log in to the RMA system of the website or and contact your distributor or sales representative for assistance.

# Table of Contents

---

<b>Compliance</b> .....	<b>iii</b>
<b>Important Safety Information</b> .....	<b>iv</b>
<b>WARNING</b> .....	<b>iv</b>
<b>CAUTION</b> .....	<b>v</b>
<b>Warranty Policy</b> .....	<b>v</b>
<b>Technical Support &amp; Services</b> .....	<b>v</b>
<b>Chapter 1 General Information</b> .....	<b>1</b>
1.1 Introduction .....	2
1.2 Features.....	2
1.3 Packing List .....	2
1.4 Specifications.....	3
1.5 Dimensions .....	5
<b>Chapter 2 Hardware Configuration</b> .....	<b>6</b>
2.1 Installations.....	7
2.1.1 Memory Installation .....	8
2.1.2 Mini-PCIe & mSATA Cards Installation .....	8
2.1.3 Mounting Brackets Installation .....	9
2.2 Setting the Jumpers .....	10
2.2.1 How to Set Jumpers .....	10
2.3 Jumper & Connector Locations on Motherboard .....	11
2.4 Jumpers Quick Reference.....	12
2.4.1 LVDS Panel Brightness Selection (JP1).....	12
2.4.2 LVDS Panel Power Selection (JP2) .....	13
2.4.3 eDP Panel Power Selection (JP3).....	13
2.4.4 eDP / LVDS Panel Selection (JP4).....	14
2.4.5 ATX / AT Power Selection (JP5) .....	14
2.4.6 Clearing CMOS Data (JP6).....	15
2.4.7 Clearing ME Register (JP7).....	15
2.5 Connectors Quick Reference .....	16
2.5.1 eDP Connector (CN1) .....	17
2.5.2 Console COM1 RS-232/422/485 Port (CN7) .....	18
2.5.3 SATA HDD Power Connector (J10) .....	19
2.5.4 COM2 / COM3 / COM4 RS-232 Port (J16, J17, J12) .....	20

2.5.5	Digital I/O Connector (J18)	20
2.5.6	DC Power Input Connector (J19)	21
<b>Chapter 3</b>	<b>Driver Installation</b>	<b>22</b>
3.1	Introduction	23
3.2	Intel® Chipset Software Installation Utility	23
3.3	Intel® Graphics Driver Installation	24
3.4	HD Audio Driver Installation	25
3.5	Intel® Trusted Execution Engine Drivers Installation	25
3.6	Intel® Serial I/O Drivers Installation	26
3.7	LAN Driver Installation	27
<b>Chapter 4</b>	<b>BIOS Setup</b>	<b>28</b>
4.1	Introduction	29
4.2	BIOS Setup	29
4.3	Main Settings	30
4.4	Advanced Settings	31
4.4.1	ACPI Settings	32
4.4.2	LVDS (eDP/DP) Configuration	33
4.4.3	Fintek Super IO Configuration	34
4.4.4	Fintek Super IO Hardware Monitor	36
4.4.5	M.2 Setup	37
4.4.6	CPU Configuration	38
4.4.7	AMI Graphic Output Protocol Policy	39
4.4.8	Network Stack Configuration	40
4.4.9	CSM Configuration	41
4.4.10	USB Configuration	42
4.5	Chipset Settings	43
4.5.1	North Bridge	43
4.5.2	South Cluster Configuration	44
4.6	Security Settings	48
4.7	Boot Settings	49
4.8	Save & Exit Settings	50
<b>Appendix</b>		<b>51</b>
A.	I/O Port Address Map	52
B.	Interrupt Request Lines (IRQ)	54
C.	Watchdog Timer Configuration	55



# Chapter 1

## General Information

The information provided in this chapter includes:

- Features
- Packing List
- Specifications
- Overview
- Dimensions

## 1.1 Introduction

ARD-042-N is an all-in-one fanless digital signage player that comes with the Intel® Pentium® N4200 QC processor. It features a rich set of I/Os such as HDMI, DisplayPort, RS-232/422/485 serial port and USB, and supports two DDR3L-1866 slots for a maximum into those small spaces, giving customers sharp and crisp messages under ambient conditions and making it perfect for displaying content on public transit or restaurant menu boards.



## 1.2 Features

- Ruggedized, fanless and compact design
- 42" color TFT active matrix, wide LCD with optimum resolution 1920 x 480
- Intel® Pentium® N4200 1.1 ~ 2.5 GHz with Intel® SoC integrated Gen. 9 18 EUs graphics
- 2 x DDR3L-1866 SO-DIMM, dual channel, Max. 8 GB (Non-ECC)
- 1 x M.2 B key (3042) for storage or 4G LTE options
- 2 x RJ45 for Gigabit LAN
- 1 x HDMI 1.4b
- 1 x DP 1.2

## 1.3 Packing List

Your device package should include the items listed below. If any of the items below is missing, contact the distributor or the dealer from whom you purchased the product.

- |                               |     |
|-------------------------------|-----|
| • ARD-042-N                   | x 1 |
| • Power Adapter               | x 1 |
| • Power Cord                  | x 1 |
| • Wall Mount Kit (2 brackets) | x 1 |
| • Screw for Wall Mount Kit    | x 8 |

## 1.4 Specifications

<b>Product Name</b>	<b>ARD-042-N</b>
<b>System</b>	
<b>Motherboard</b>	IB811F-420
<b>Operating System</b>	Windows 10 Enterprise (32-bit / 64-bit)
<b>CPU</b>	Intel® Pentium® QC N4200 1.1 ~ 2.5 GHz, 2 MB cache, socket FCBGA1296 (24 ~ 31 mm)
<b>Chipset</b>	Integrated
<b>Memory</b>	2 x DDR3L-1866 SO-DIMM, expandable up to 8 GB (Non-ECC)
<b>Network</b>	Intel® I210IT or I210AT PCIe GbE LAN
<b>Graphics</b>	Intel® SoC integrated Gen. 9 18EUs Gfx
<b>Super I/O</b>	Fintek F81964
<b>Storage</b>	1 x mSATA
<b>Audio Codec</b>	Intel® SoC built-in HD audio controller Realtek ALC283QHD codec with speaker amplifier
<b>Power Supply</b>	180W power adapter
<b>BIOS</b>	AMI BIOS
<b>Watchdog</b>	Watchdog Timer 256 segments, 0, 1, 2...255 sec/min
<b>H/W Monitor</b>	Yes
<b>Chassis</b>	Aluminum & SGCC, black
<b>Mounting</b>	Side mounting
<b>Dimensions (W x H x D)</b>	1065.1 x 70 x 287.9 mm (41.93" x 2.75" x 11.33")
<b>Net Weight</b>	14.8 kg (32.63 lb)
<b>Certificate</b>	CE, FCC Class B, cULus, CCC
<b>Display</b>	
<b>Display Type</b>	42" color TFT active matrix, wide LCD
<b>Display Area</b>	1039.68 (H) x 259.92 (V)
<b>Display Surface</b>	Anti-glare coating (Haze 44%)
<b>Resolution</b>	Max. 1920 x 480
<b>Viewing Angle</b>	178° (H) / 178° (V)
<b>Response Time</b>	8 ms (typ.)

<b>Contrast</b>	4000:1
<b>Backlight Lifetime</b>	50000 hrs
<b>Brightness</b>	550 nits
<b>I/O Ports</b>	
<b>DC Jack</b>	24V DC-In (180W power supply)
<b>Display</b>	<ul style="list-style-type: none"><li>• 1 x HDMI (1.4b), 3840 x 2160 at 30 Hz</li><li>• 1 x DisplayPort (1.2), 4096 x 2160 at 60 Hz</li></ul>
<b>LAN</b>	2 x RJ45 GbE LAN
<b>USB</b>	4 x USB 3.0
<b>Serial</b>	1 x COM Port (RS-232/422/485, jumperless selection)
<b>Expansion</b>	1 x M.2 B3042 Slot with PCIe (x1), USB and SATA
<b>Environment</b>	
<b>Temperature</b>	<ul style="list-style-type: none"><li>• <b>Operating:</b> 0 ~ 40 °C (32 ~ 104 °F)</li><li>• <b>Storage:</b> -20~ 80 °C (-4 ~ 176 °F)</li></ul>
<b>Relative Humidity</b>	5 ~ 90% at 45 °C (non-condensing)
<b>Vibration Protection</b>	IEC 61373 (Vibration Class B)

All specifications are subject to change without prior notice.

## 1.5 Dimensions

Unit: mm

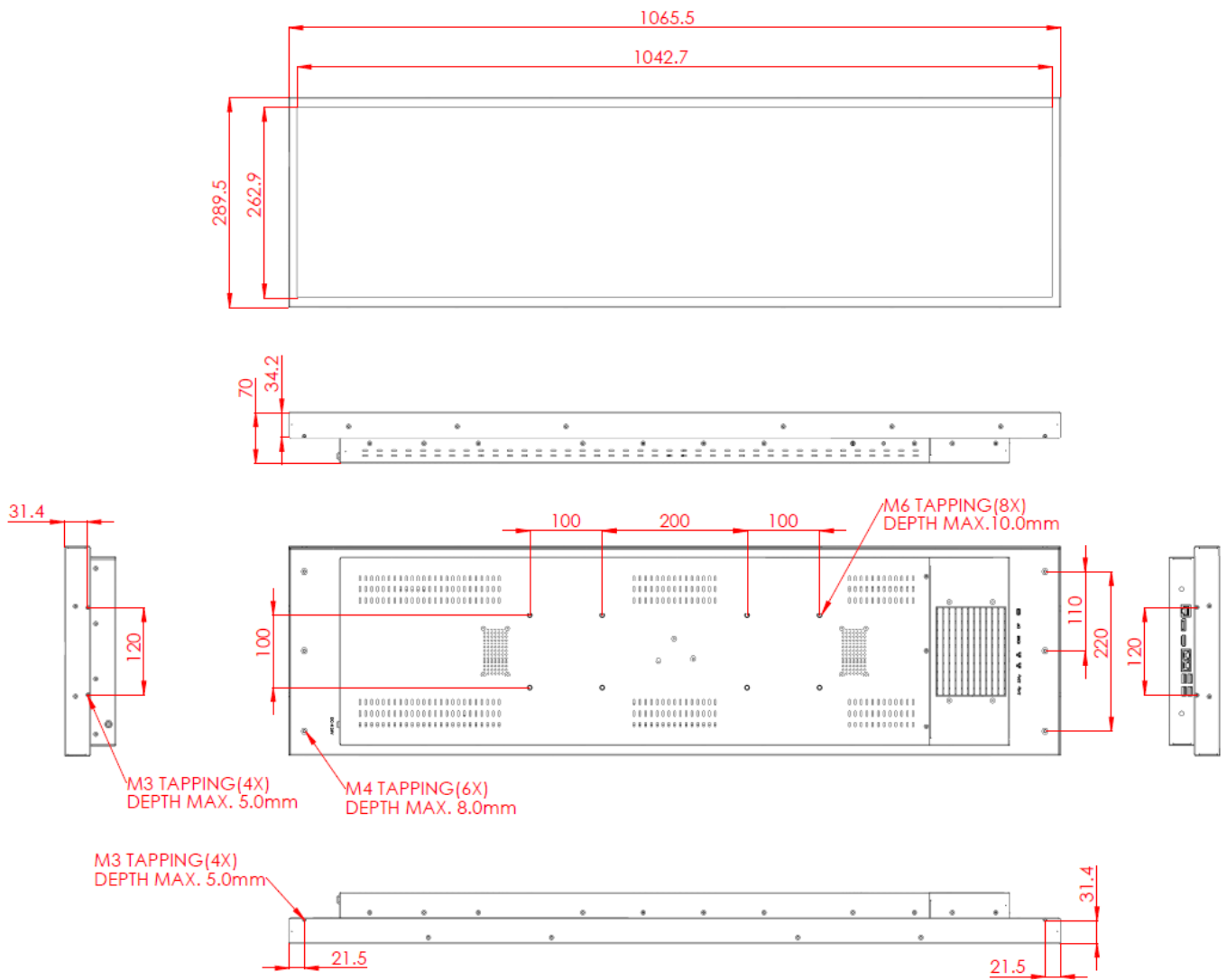

## Chapter 2

# Hardware Configuration

The information provided in this chapter includes:

- Essential installations before you begin
- Information and locations of connectors

## 2.1 Installations

For all the installation or replacement of the memory modules, mSATA card and wireless card, you need to open the rear device cover. Follow the instructions below.

1. Remove 7 screws as indicated below to open the cover marked in yellow below with the motherboard mounted inside.

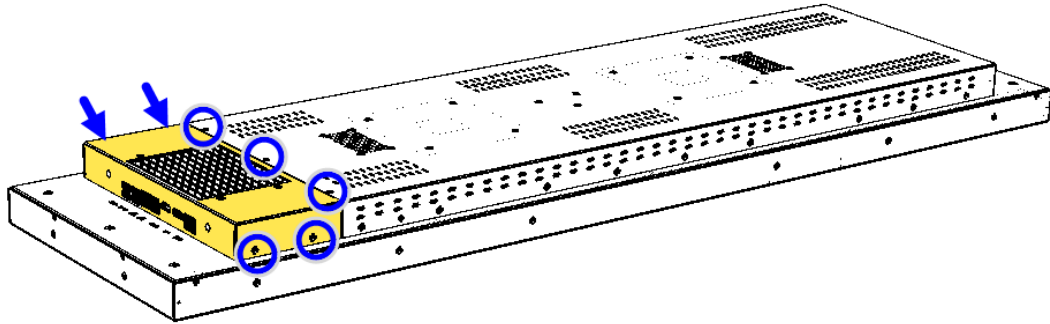

2. Lift it carefully in case the cables or thermal pad(s) may fall off.

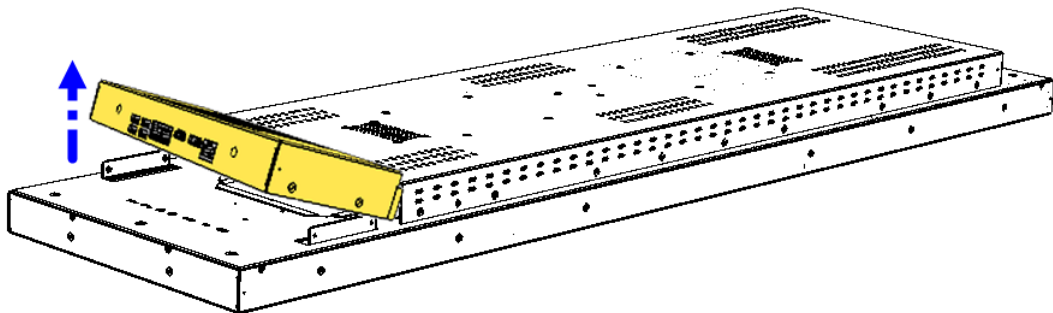

3. Then flip over the cover as shown below.

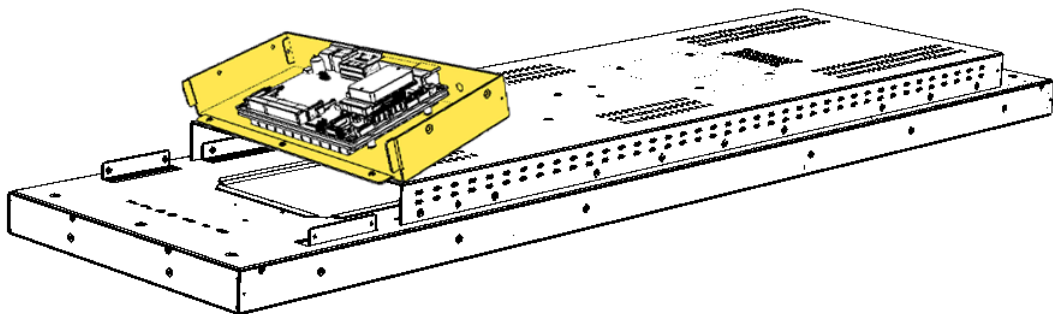

## 2.1.1 Memory Installation

If you need to install or replace a memory module, locate the memory slot inside the device and perform the following steps.

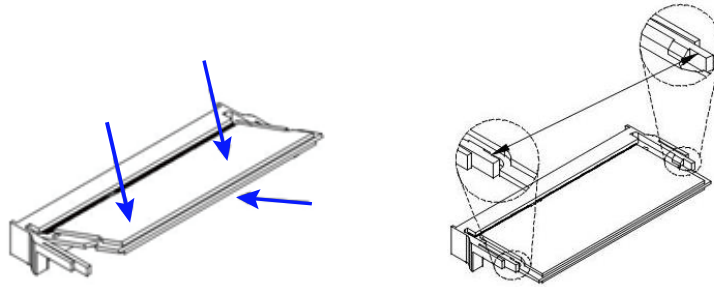

1. Align the key of your memory module with that on the memory slot and insert the module slantwise.
2. Gently push the module in an upright position until the clips of the slot click to hold the module in place when the module touches the bottom of the slot.

To remove the module, press the clips outwards with both hands.

## 2.1.2 Mini-PCle & mSATA Cards Installation

If you need to replace or install the mini-PCle or mSATA card, locate the mini-PCle slot inside the device and perform the following steps.

1. Align the key of your card to the mini-PCle interface, and insert the card slantwise.

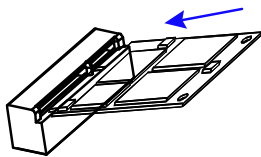

2. Push the card down and fix it with a screws of M3 x 3.8 mm.

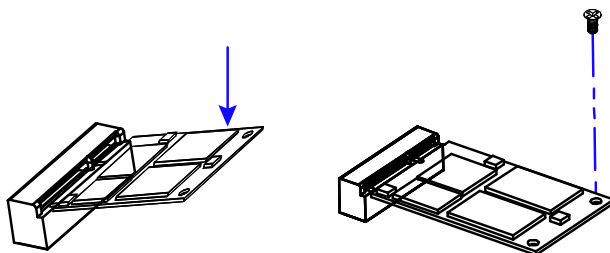

### 2.1.3 Mounting Brackets Installation

---

**Note:** Before mounting the system on wall, ensure that you are following all applicable building and electric codes.

---

#### Requirements:

Before mounting the brackets, ensure that you have enough room for power and signal cable routing. The method of mounting must be able to support weight of the system plus the suspend weight of all the cables to be attached to the system.

#### Wall mounting instructions:

1. Turn your device upside down, attach the mounting brackets to the device and secure with the supplied 10 screws.

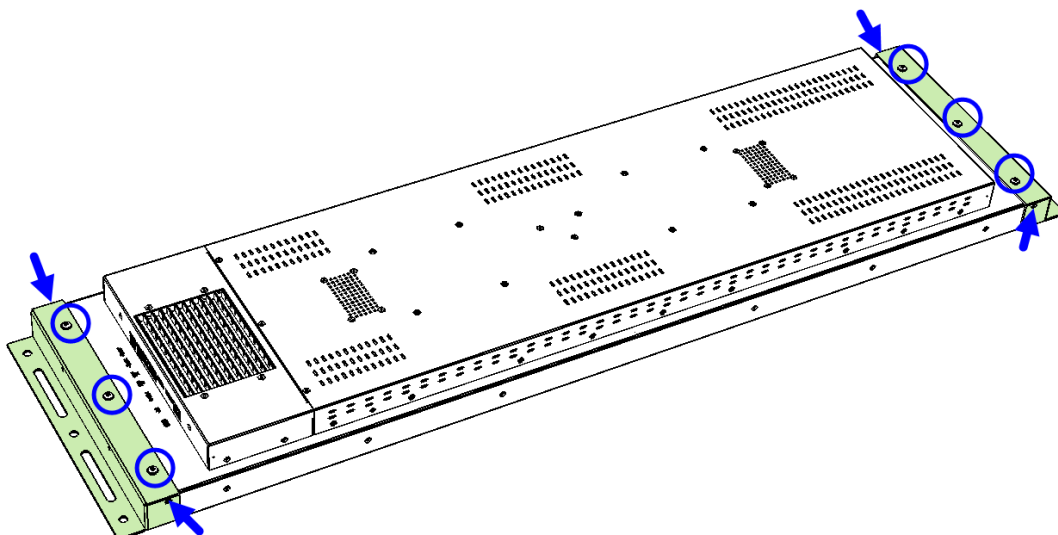

2. Then prepare at least four screws (M3, 6 mm) to mount the device on wall.

## 2.2 Setting the Jumpers

Set up and configure your device by using jumpers for various settings and features according to your needs and applications. Contact your supplier if you have doubts about the best configuration for your use.

### 2.2.1 How to Set Jumpers

Jumpers are short-length conductors consisting of several metal pins with a non-conductive base mounted on the circuit board. Jumper caps are used to have the functions and features enabled or disabled. If a jumper has 3 pins, you can connect either PIN1 to PIN2 or PIN2 to PIN3 by shorting.

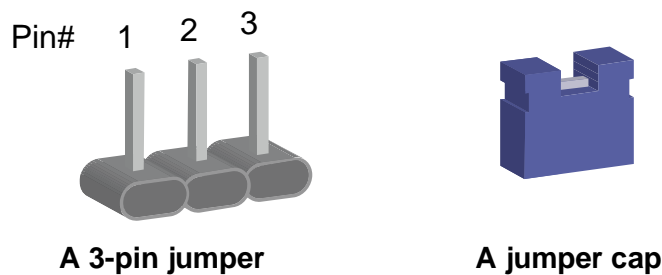

Refer to the illustration below to set jumpers.

Pin closed	Oblique view	Illustration
Open		
1-2		
2-3		

When two pins of a jumper are encased in a jumper cap, this jumper is **closed**, i.e. turned **On**.

When a jumper cap is removed from two jumper pins, this jumper is **open**, i.e. turned **Off**.



## 2.4 Jumpers Quick Reference

Function	Connector Name	Page
LCD Panel Brightness Selection	JP1	12
LVDS Panel Power Selection	JP2	13
eDP Panel Power Selection	JP3	13
eDP / LVDS Panel Seelction	JP4	14
ATX / AT Power Selection	JP5	14
Clearing CMOS Data	JP6	15
Clearing ME Register	JP7	15
Factory Use Only	JP8	--

### 2.4.1 LVDS Panel Brightness Selection (JP1)

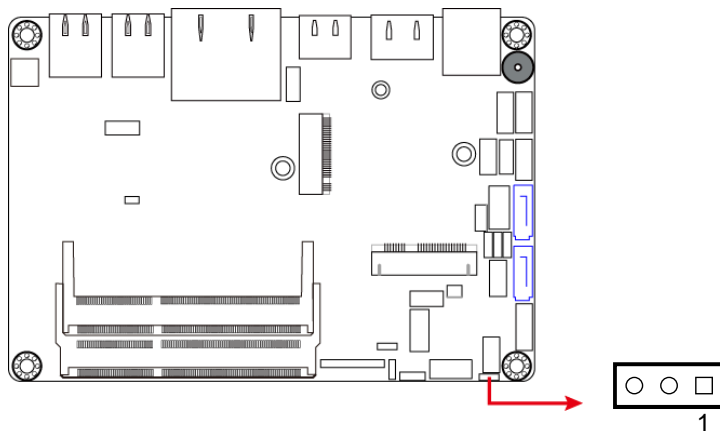

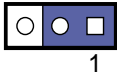
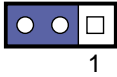
Function	Pin closed	Illustration
3.3V (default)	1-2	
5V	2-3	

### 2.4.2 LVDS Panel Power Selection (JP2)

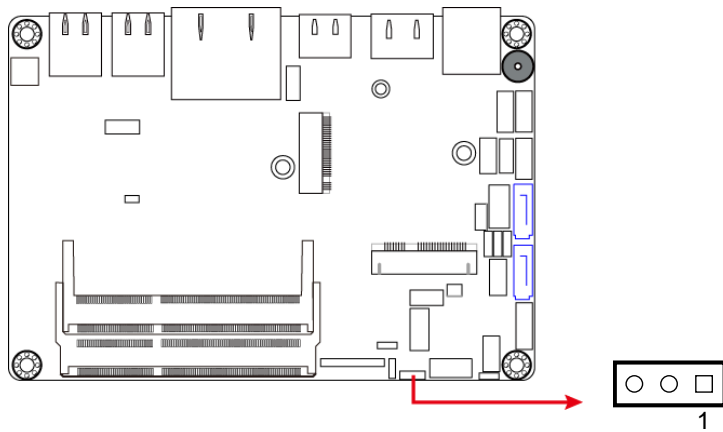

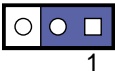
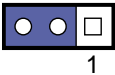
Function	Pin closed	Illustration
3.3V (default)	1-2	
5V	2-3	

### 2.4.3 eDP Panel Power Selection (JP3)

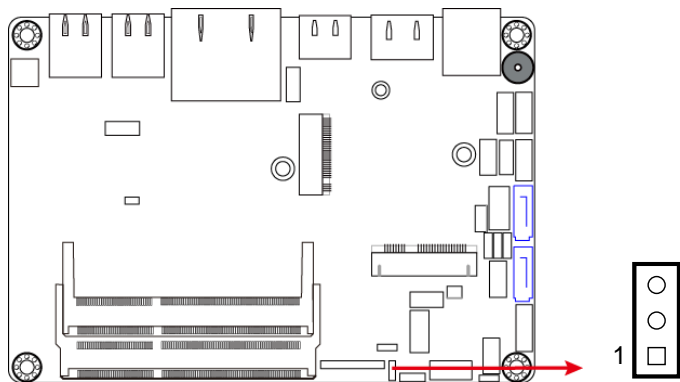

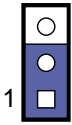
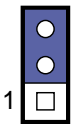
Function	Pin closed	Illustration
3.3V (default)	1-2	
5V	2-3	

**2.4.4 eDP / LVDS Panel Selection (JP4)**

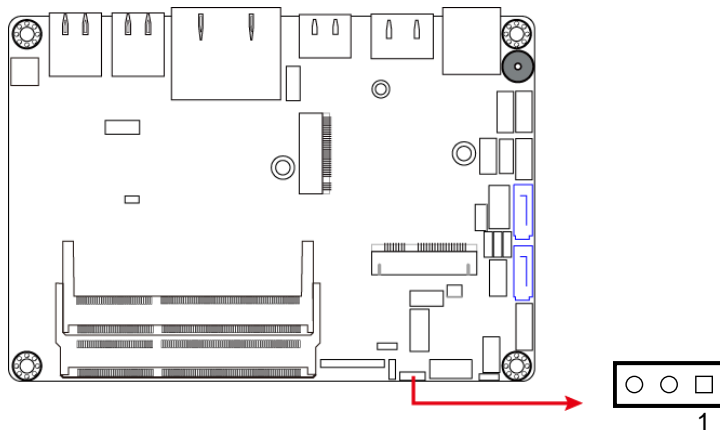

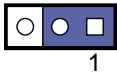
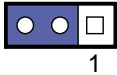
Function	Pin closed	Illustration
eDP	1-2	
LVDS (default)	2-3	

**2.4.5 ATX / AT Power Selection (JP5)**

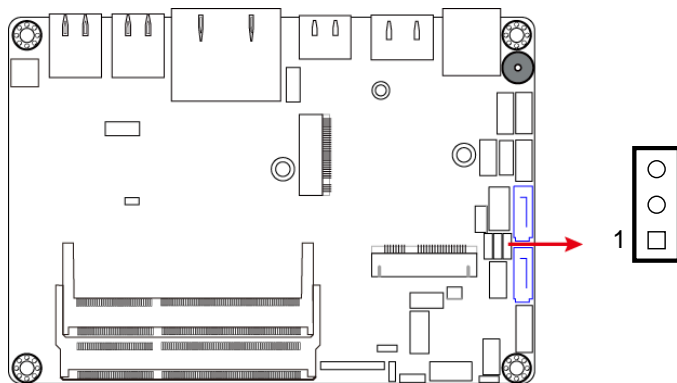

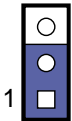
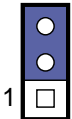
Function	Pin closed	Illustration
ATX (default)	1-2	
AT	2-3	

### 2.4.6 Clearing CMOS Data (JP6)

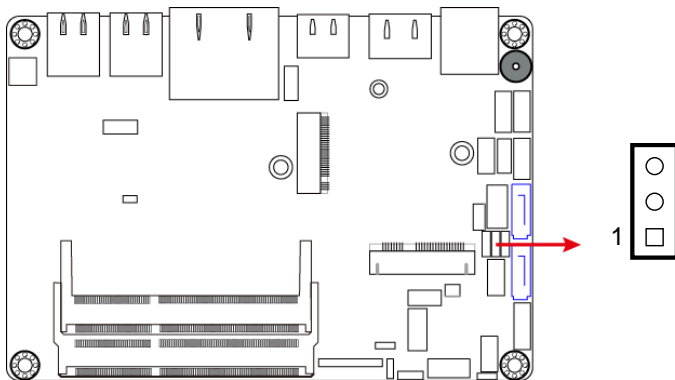

Function	Pin closed	Illustration
Normal (default)	1-2	
Clear CMOS	2-3	

### 2.4.7 Clearing ME Register (JP7)

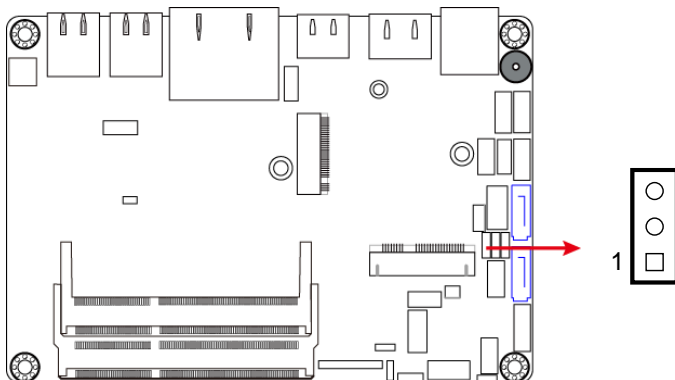

Function	Pin closed	Illustration
Normal (default)	1-2	
Clear ME Register	2-3	

## 2.5 Connectors Quick Reference

Function	Connector Name	Page
eDP Connector	CN1	17
Console COM1 (RJ10) RS-232/422/485 Port	CN7	18
SATA HDD Power Connector	J10	19
COM2 / COM3 / COM4 RS-232 Port	J16, J17, J12	20
Digital I/O Connector	J18	20
DC Power Input Connector	J19	21
SATA III Connector	CN2 (shared with M.2 B-key) CN3 (shared with mSATA)	--
LAN Ports	CN4	--
USB 3.0 Ports	CN5, CN6	--
DisplayPort	CN8	--
HDMI Port	CN9	--
LCD Backlight Connector	J2	--
LVDS Connector	J1, J3	--
Audio Connector	J4	--
DDR3L SO-DIMM Slot	J5, J8	--
USB 2.0 Connector	J6	--
Amplifier Connector	J7	--
Mini PCIe / mSATA Slot	J11	--
M.2 (B key) 3042 Slot	J14	--
Front Panel Connector	J13	--
Factory Use Only	J15, J20, J21	--

### 2.5.1 eDP Connector (CN1)

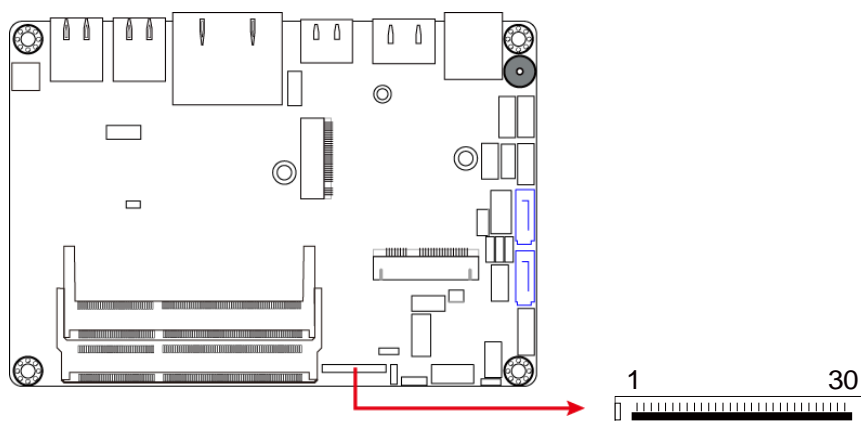

Pin	Assignment	Pin	Assignment
1	NC	16	Ground
2	BL_Power	17	NC
3	BL_Power	18	Panel_VDD
4	BL_Power	19	Panel_VDD
5	BL_Power	20	Ground
6	NC	21	AUX_N
7	NC	22	AUX_P
8	BRIGHTNESS	23	Ground
9	Bklt_en	24	TX0_P
10	Ground	25	TX0_N
11	Ground	26	Ground
12	Ground	27	TX1_P
13	Ground	28	TX1_N
14	HPD	29	Ground
15	Ground	30	NC

**2.5.2 Console COM1 RS-232/422/485 Port (CN7)**

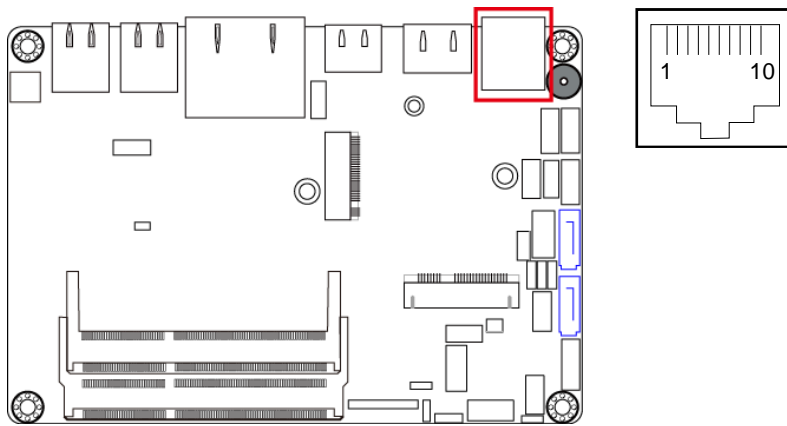

COM1 port is jumper-less and configurable in BIOS.

Pin	Assignment	Pin	Assignment
1	DSR, Data set ready	6	DCD, Data carrier detect
2	Ground	7	DTR, Data terminal ready
3	Ground	8	CTS, Clear to send
4	TX, Transmit	9	RTS, Request to send
5	RX, Receive	10	RI, Ring Indicator

Pin	Assignment		
	RS-232	RS-422	RS-485
1	DSR	NC	NC
2	Ground	Ground	Ground
3	Ground	Ground	Ground
4	TX	RX+	NC
5	RX	TX+	Data+
6	DCD	TX-	Data-
7	DTR	RX-	NC
8	CTS	NC	NC
9	RTS	NC	NC
10	RI	NC	NC

**2.5.3 SATA HDD Power Connector (J10)**

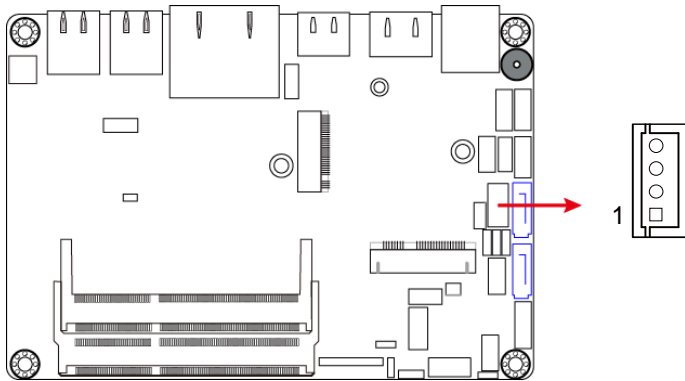

Pin	Assignment	Pin	Assignment
1	+5V	3	Ground
2	Ground	4	+12V

**2.5.4 COM2 / COM3 / COM4 RS-232 Port (J16, J17, J12)**

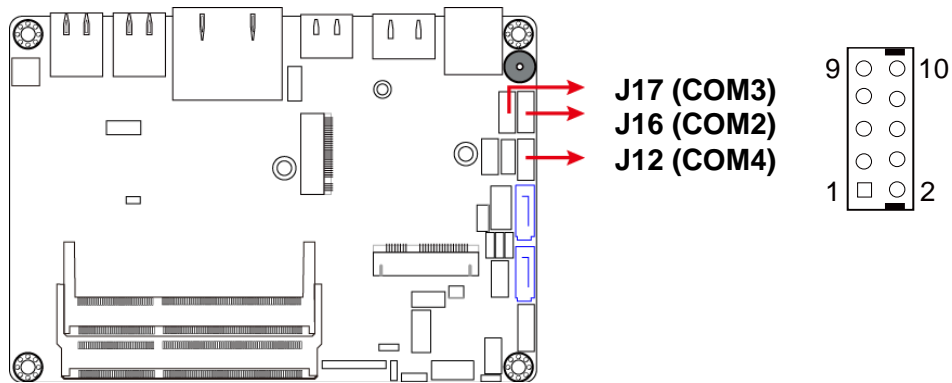

Pin	Assignment	Pin	Assignment
1	DCD, Data carrier detect	2	RXD, Receive data
3	TXD, Transmit data	4	DTR, Data terminal ready
5	Ground	6	DSR, Data set ready
7	RTS, Request to send	8	CTS, Clear to send
9	RI, Ring indicator	10	Not Used

**2.5.5 Digital I/O Connector (J18)**

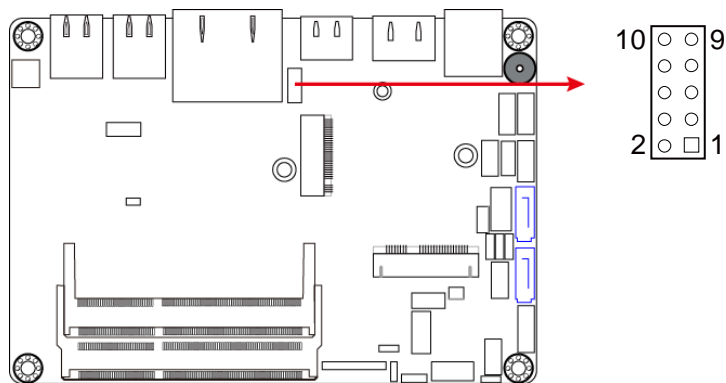

Pin	Assignment	Pin	Assignment
1	Ground	2	VCC
3	OUT3	4	OUT1
5	OUT2	6	OUT0
7	IN3	8	IN1
9	IN2	10	IN0

**2.5.6 DC Power Input Connector (J19)**

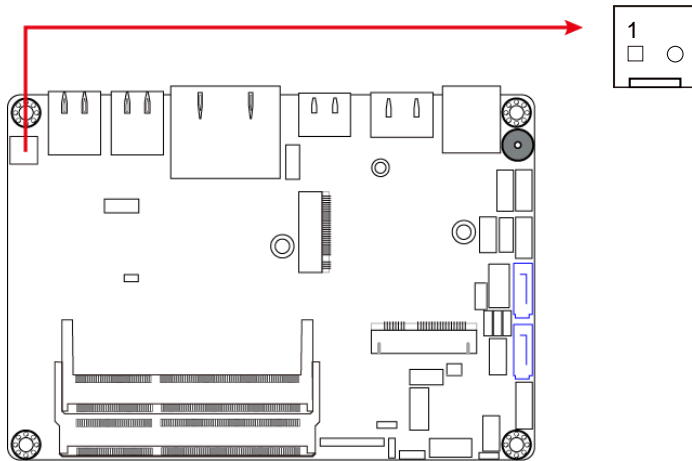

Pin	Assignment	Pin	Assignment
1	+9V ~ +36V	2	Ground

## Chapter 3

# Driver Installation

The information provided in this chapter includes:

- Intel® Chipset Software Installation Utility
- Intel® Graphics Driver Installation
- HD Audio Driver Installation
- Intel® Trusted Execution Engine Installation
- Intel® USB 3.0 Driver Installation
- LAN Driver Installation

### 3.1 Introduction

This section describes the installation procedures for software drivers.

---

**Note:** After installing your Windows operating system, you must install the Intel® Chipset Software Installation Utility first before proceeding with the drivers installation.

---

### 3.2 Intel® Chipset Software Installation Utility

The Intel® Chipset drivers should be installed first before the software drivers to install INF files for Plug & Play function for the chipset components. Follow the instructions below to complete the installation.

1. Go to the download page of the product. Copy the compressed drivers file to your computer. Double click the file to decompress it. Run “CDGuide” to go to the main drivers page (files). Run the **Setup.exe** file.
2. When the *Welcome* screen to the Intel® Chipset Device Software appears, click **Next** to continue.

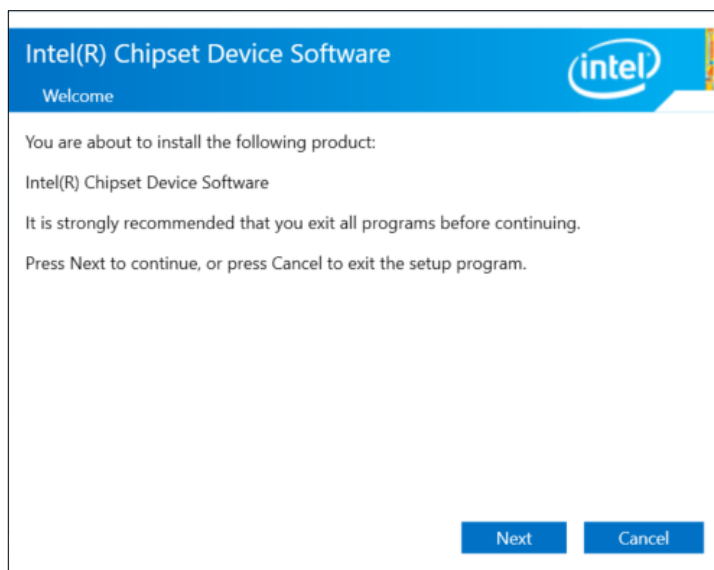

3. Accept the license agreement.

4. On the *Readme File Information* screen, click **Install**.

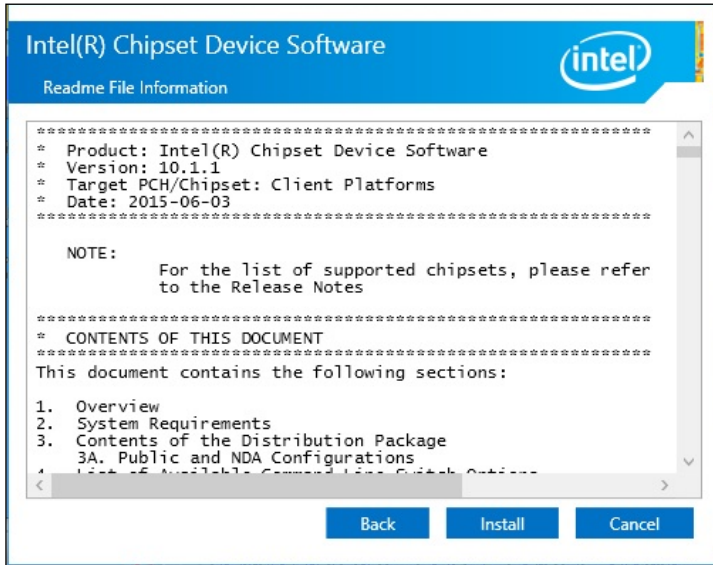

5. The driver has been completely installed. You are suggested to restart the computer for changes to take effect.

### 3.3 Intel® Graphics Driver Installation

1. Run the **Setup.exe** file.
2. When the *Welcome* screen appears, click **Next** to continue.

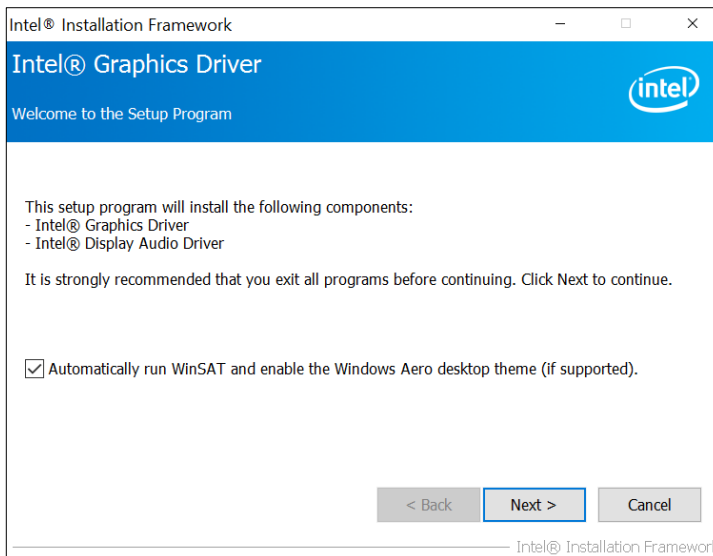

3. Click **Yes** to agree with the license agreement and continue the installation.
4. On the *Readme File Information* screen, click **Next** for installation.
5. The driver has been completely installed. You are suggested to restart the computer for changes to take effect.

### 3.4 HD Audio Driver Installation

1. Run the **Setup.exe** file.
2. On the *Welcome* screen of the InstallShield Wizard, click **Next** for installation.

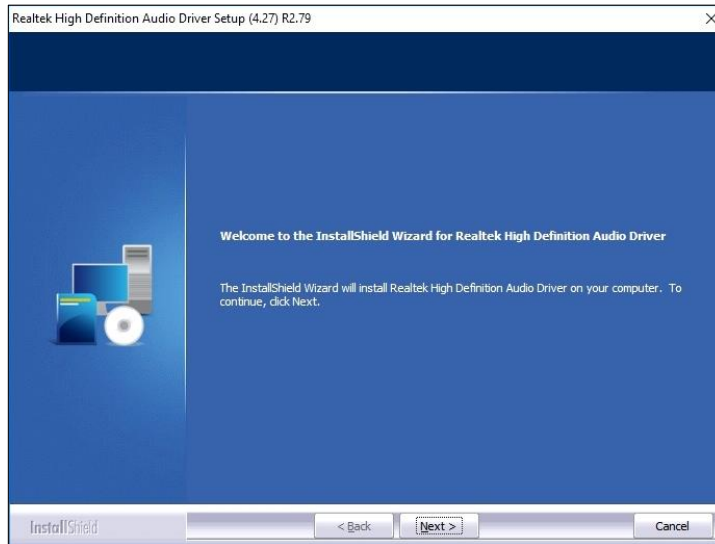

3. Click **Next** until the installation starts.
4. The driver has been completely installed. Restart the computer for changes to take effect.

### 3.5 Intel® Trusted Execution Engine Drivers Installation

1. Run the **Setup.exe** file.
2. When the *Welcome* screen appears, click **Next**.

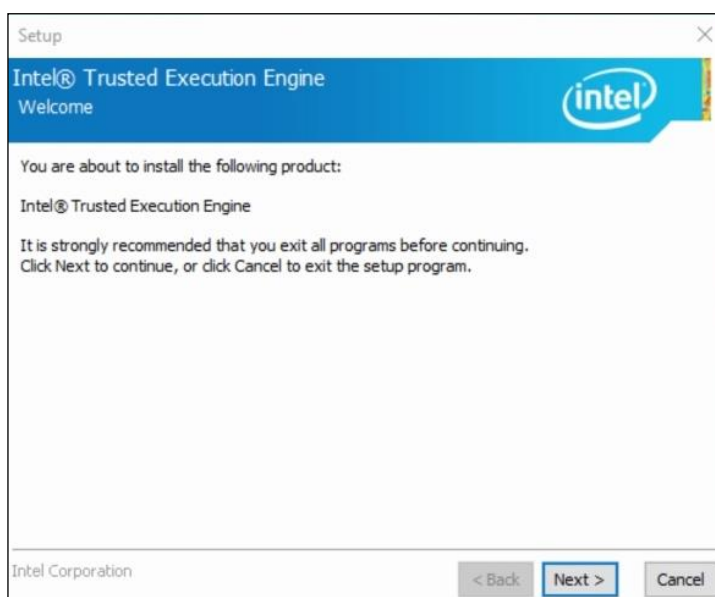

# iBASE

3. Accept the license agreement and click **Next**.
4. Click **Next** for installation.

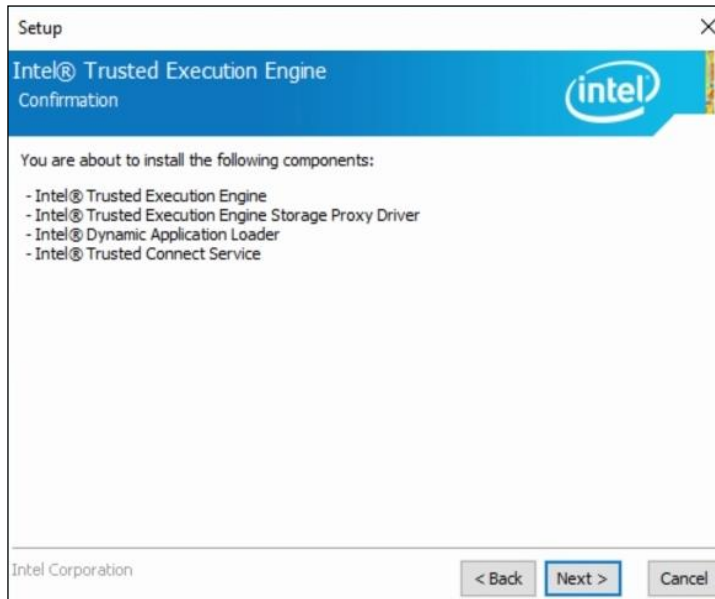

5. The driver has been completely installed. Restart the computer and for changes to take effect.

## 3.6 Intel® Serial I/O Drivers Installation

1. Run the **Setup.exe** file.
2. When the *Welcome* screen appears, click **Next**.

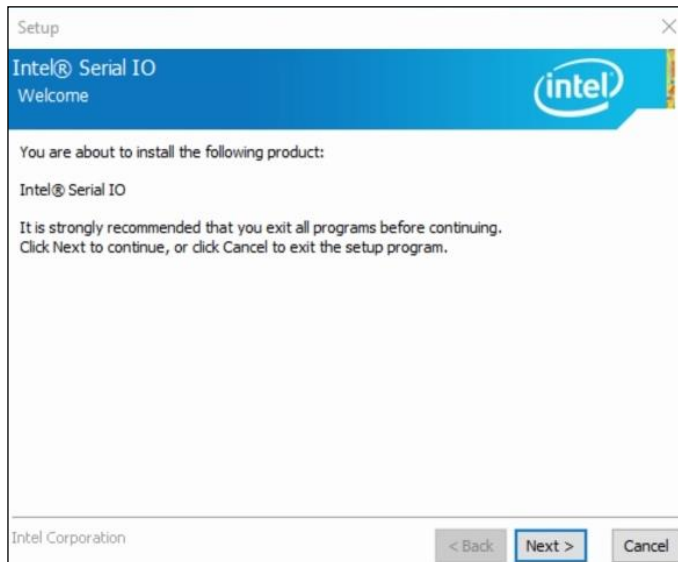

3. Accept the license agreement and click **Next**.
4. After reading the *Readme File Information*, click **Next** for installation.
5. As the driver has been completely installed, restart the computer and for changes to take effect.

### 3.7 LAN Driver Installation

1. Run the **Setup.exe** file.
2. On the *Welcome* screen of the InstallShield Wizard, click **Next**.

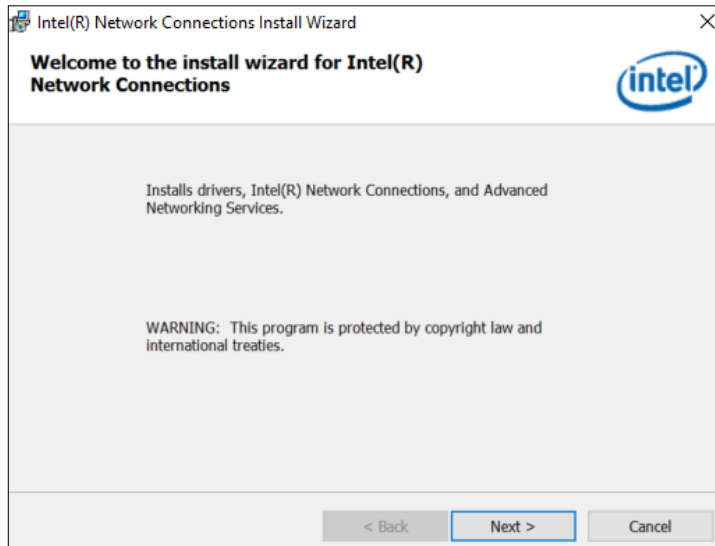

3. Accept the license agreement and click **Next** to continue.
4. On the *Setup Options* screen, click the checkbox to select the desired driver(s) for installation. Then click **Next** to continue.

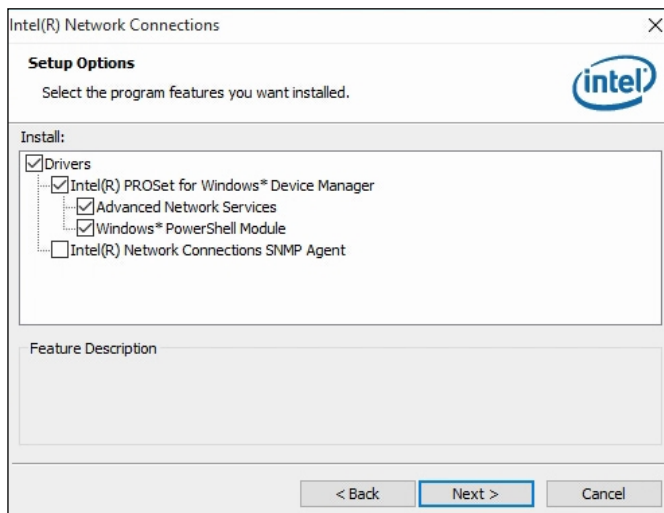

5. When the wizard is ready for installation, click **Install**.
6. As the driver has been completely installed, restart the computer and for changes to take effect.

## Chapter 4

# BIOS Setup

This chapter describes the different settings available in the AMI BIOS that comes with the board. The topics covered in this chapter are as follows:

- Main Settings
- Advanced Settings
- Chipset Settings
- Security Settings
- Boot Settings
- Save & Exit

## 4.1 Introduction

The BIOS (Basic Input/Output System) installed in the ROM of your computer system supports Intel® processors. The BIOS provides critical low-level support for standard devices such as disk drives, serial ports and parallel ports. It also provides password protection as well as special support for detailed fine-tuning of the chipset controlling the entire system.

## 4.2 BIOS Setup

The BIOS provides a Setup utility program for specifying the system configurations and settings. The BIOS ROM of the system stores the Setup utility. When you turn on the computer, the BIOS is immediately activated. Press the <Del> key immediately allows you to enter the Setup utility. If you are a little bit late pressing the <Del> key, POST (Power On Self Test) will continue with its test routines, thus preventing you from invoking the Setup.

If you still need to enter Setup, restart the system by pressing the "Reset" button or simultaneously pressing the <Ctrl>, <Alt> and <Delete> keys. You can also restart by turning the system Off and back On again.

The following message will appear on the screen:

```
Press <DEL> to Enter Setup
```

In general, press the arrow keys to highlight items, <Enter> to select, the <PgUp> and <PgDn> keys to change entries, <F1> for help, and <Esc> to quit.

When you enter the BIOS Setup utility, the *Main Menu* screen will appear on the screen. The Main Menu allows you to select from various setup functions and exit choices.

---

**Warning:** It is strongly recommended that you avoid making any changes to the chipset defaults.

These defaults have been carefully chosen by both AMI and your system manufacturer to provide the absolute maximum performance and reliability. Changing the defaults could make the system unstable and crash in some cases.

---

### 4.3 Main Settings

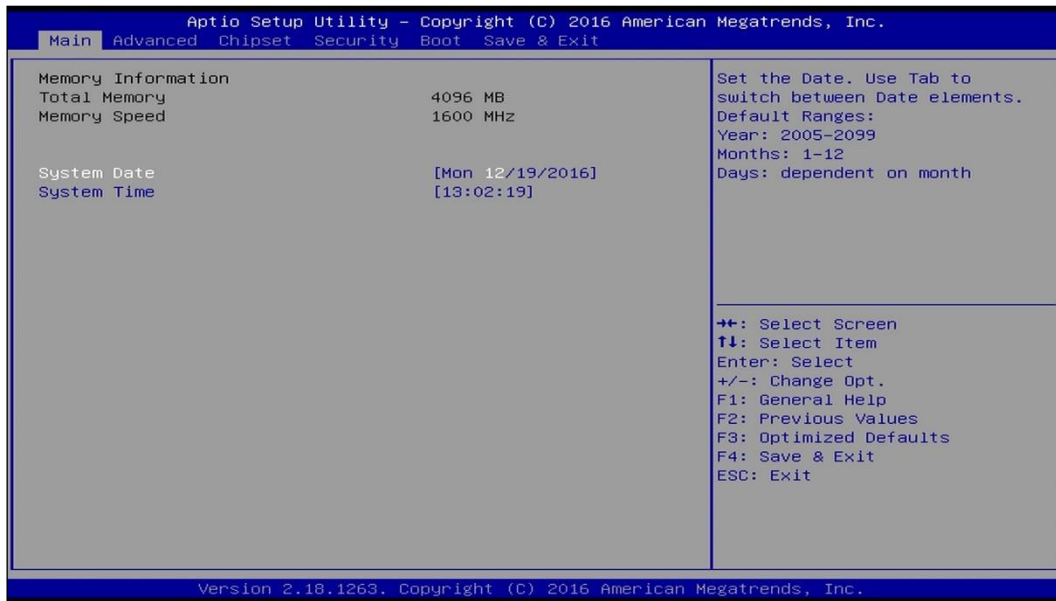

BIOS Setting	Description
System Date	Sets the date. Use the <Tab> key to switch between the date elements.
System Time	Set the time. Use the <Tab> key to switch between the time elements.

## 4.4 Advanced Settings

This section allows you to configure, improve your system and allows you to set up some system features according to your preference.

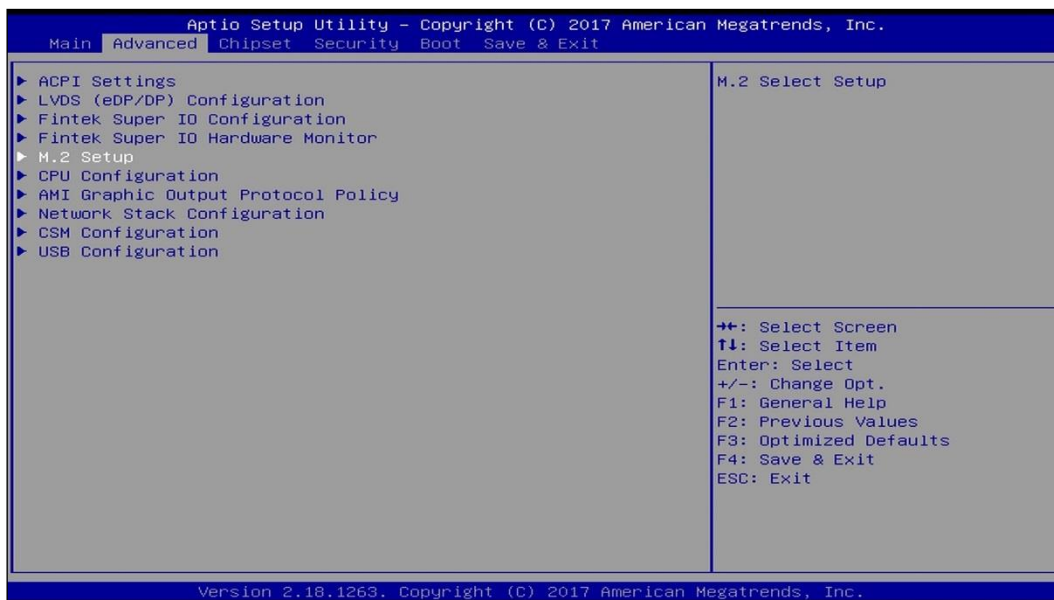

### 4.4.1 ACPI Settings

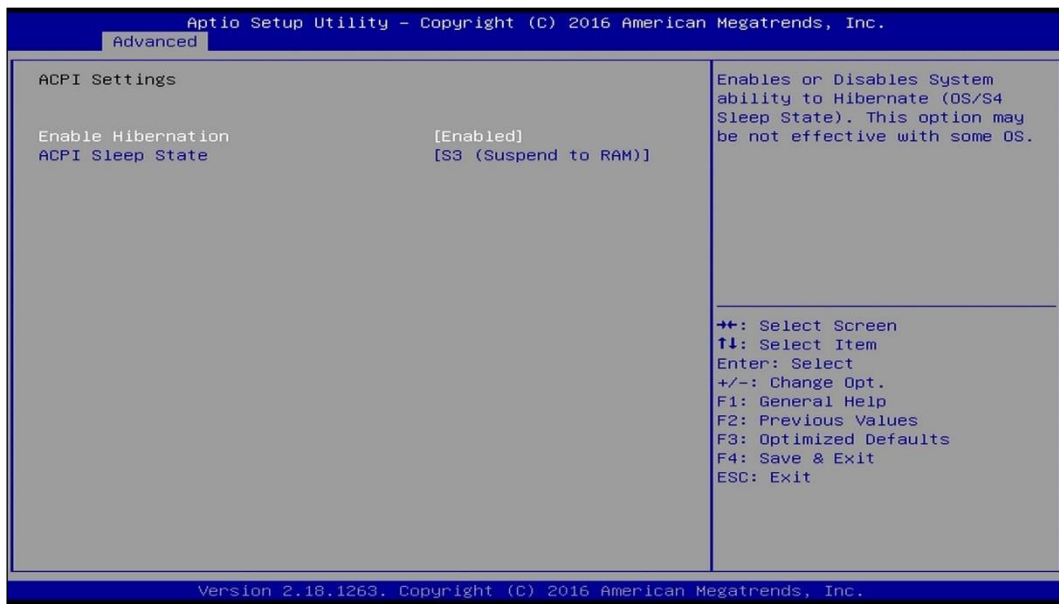

BIOS Setting	Description
Enable Hibernation	Enables / Disables the system ability to hibernate (OS/S4 Sleep State). This option may be not effective with some OS.
ACPI Sleep State	Selects an ACPI sleep state (Suspend Disabled or S3) where the system will enter when the Suspend button is pressed.

## 4.4.2 LVDS (eDP/DP) Configuration

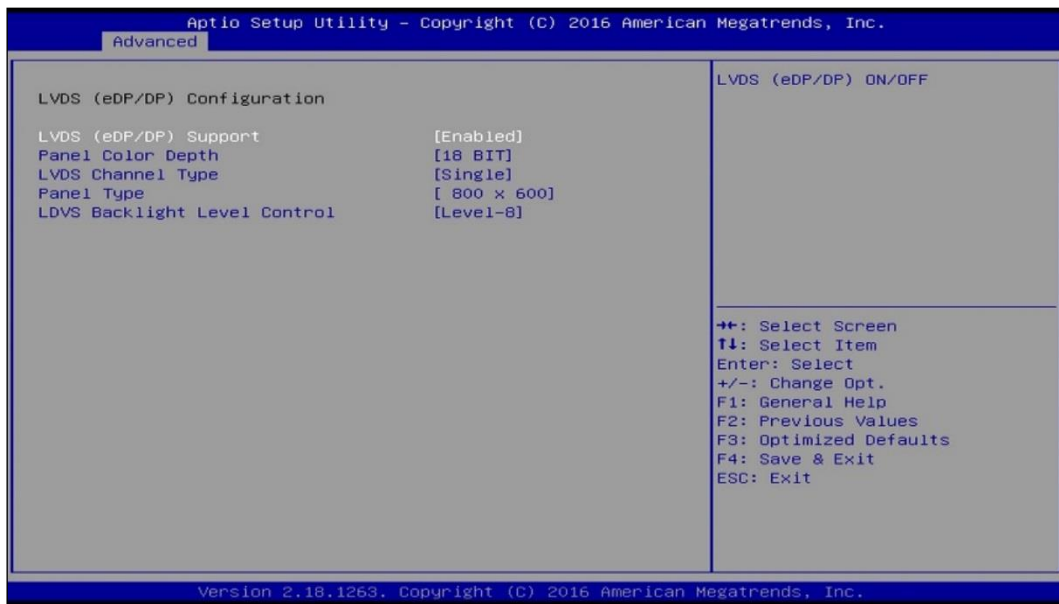

BIOS Setting	Description
LVDS (eDP/DP) Support	Enables / Disables LVDS (eDP/DP)
Panel Color Depth	Selects a panel color depth as 24 (JEIDA) bit.
LVDS Channel Type	Sets the LVDS channel type as dual channel.
Panel Type	Selects the resolution S420HW62 (1920 x 480) to fit your panel.
LVDS Backlight Level Control	Selects from Level 1 to Level 8 for the LVDS backlight.

### 4.4.3 Fintek Super IO Configuration

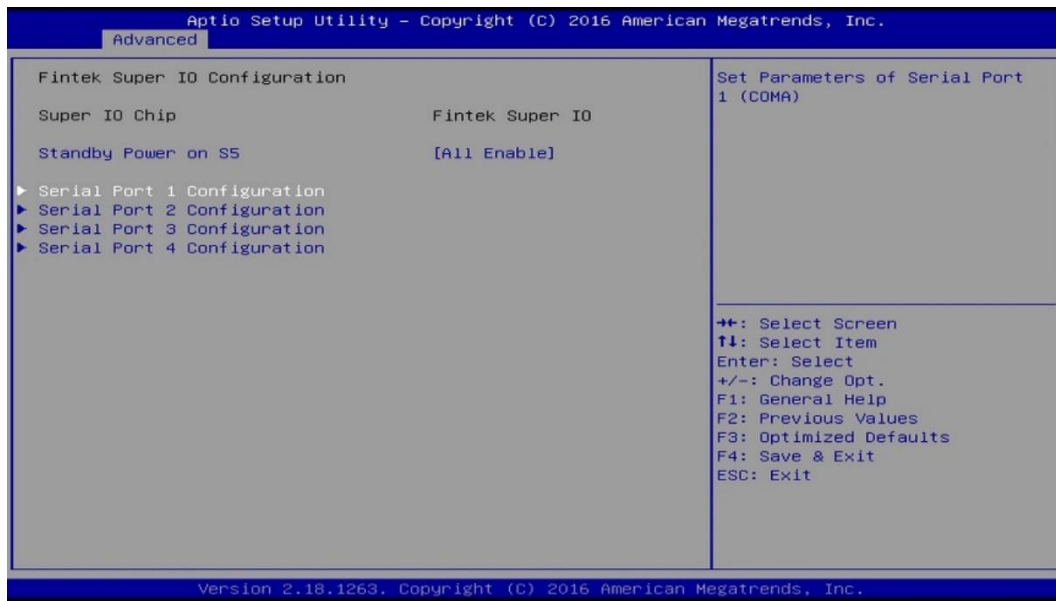

BIOS Setting	Description
Standby Power on S5	Enables / Disables to provide the standby power for devices.  Options: All Enable / Enable Ethernet for WOL / All Disable
Serial Ports Configuration	Sets parameters of serial ports.  Enables / Disables the serial port and select an optimal setting for the Super IO device.

## 4.4.3.1. Serial Port 1 Configuration

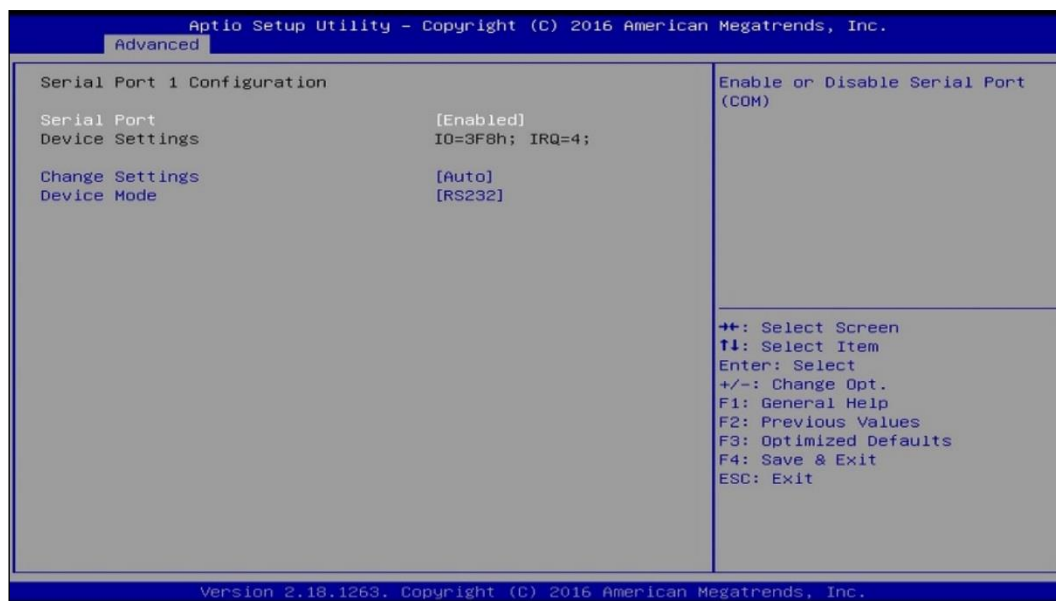

BIOS Setting	Description
Serial Port	Enables / Disables the serial port.
Change Settings	Selects an optimal settings for Super IO device.  Options: <ul style="list-style-type: none"> <li>• Auto</li> <li>• IO = 3F8h; IRQ = 4</li> <li>• IO = 3F8h; IRQ = 3, 4, 5, 6, 7, 9, 10, 11, 12</li> <li>• IO = 2F8h; IRQ = 3, 4, 5, 6, 7, 9, 10, 11, 12</li> <li>• IO = 3E8h; IRQ = 3, 4, 5, 6, 7, 9, 10, 11, 12</li> <li>• IO = 2E8h; IRQ = 3, 4, 5, 6, 7, 9, 10, 11, 12</li> </ul>
Device Mode	Changes the serial port mode to: <ul style="list-style-type: none"> <li>• RS232</li> <li>• RS485 TX Low Active</li> <li>• RS485 with Termination TX Low Active</li> <li>• RS422</li> <li>• RS422 with Termination</li> </ul>

### 4.4.4 Fintek Super IO Hardware Monitor

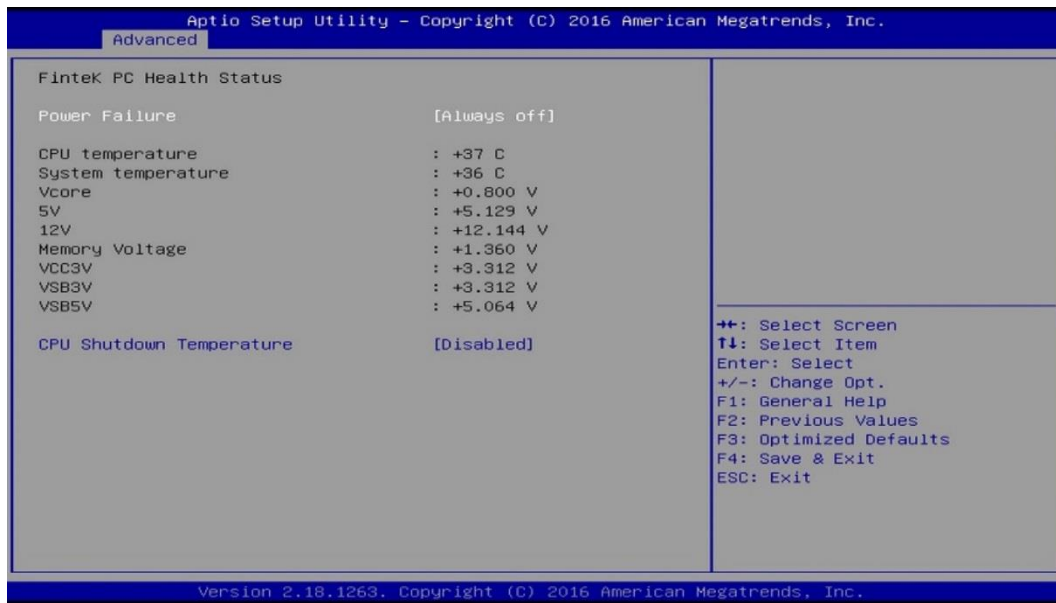

BIOS Setting	Description
Temperatures / Voltages	These fields are the parameters of the hardware monitoring function feature of the motherboard. The values are read-only values as monitored by the system and show the PC health status.
CPU Shutdown Temperature	Sets a threshold of temperature to shut down if CPU goes overheated.  Options: Disabled / 70 °C / 75 °C / 80 °C / 85 °C / 90 °C / 95 °C

### 4.4.5 M.2 Setup

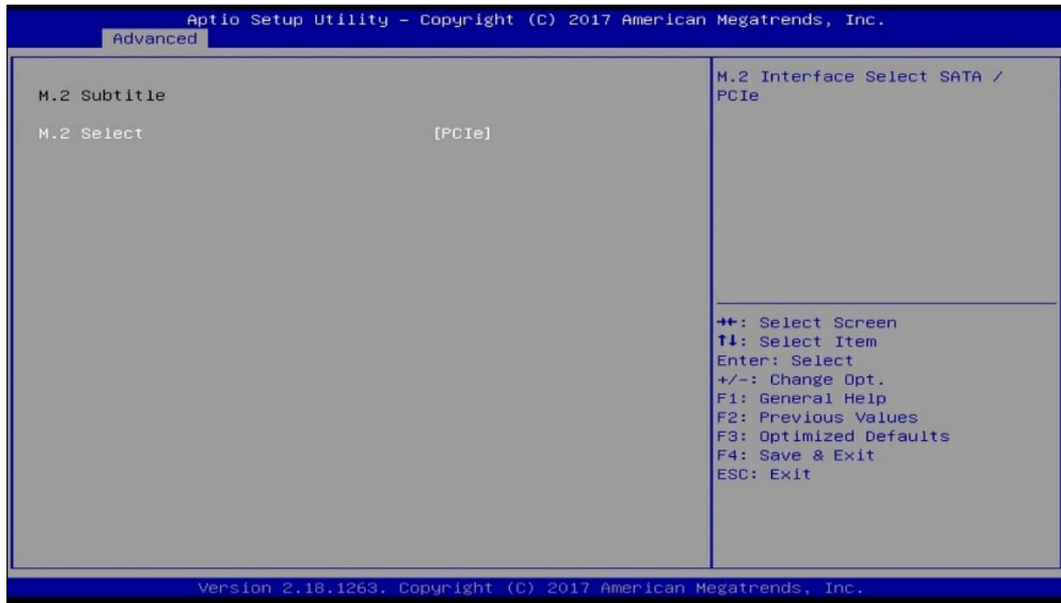

BIOS Setting	Description
M.2 Select	Selects the M.2 interface as SATA or PCIe.

## 4.4.6 CPU Configuration

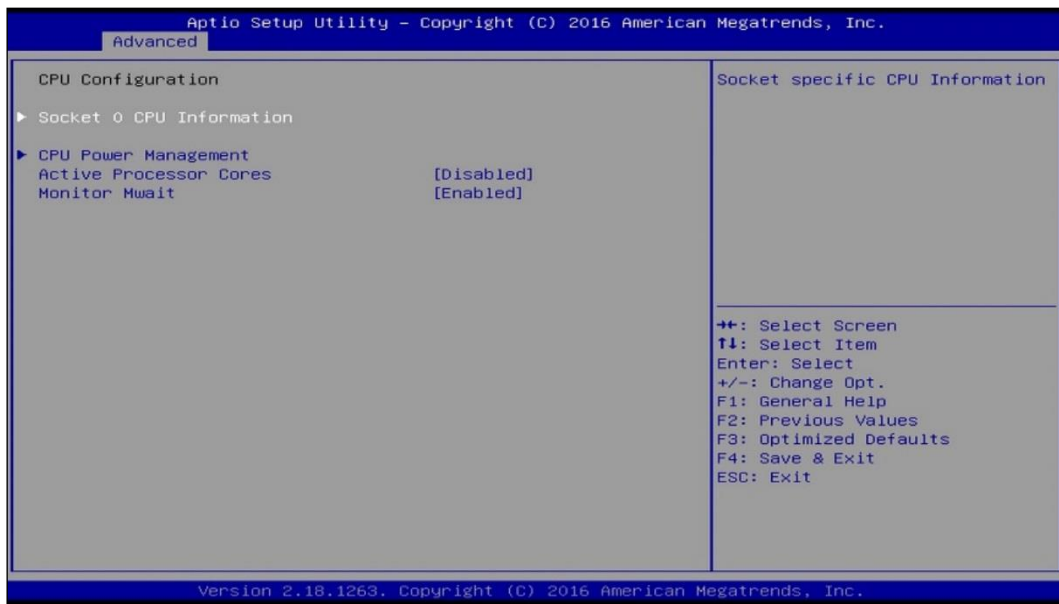

BIOS Setting	Description
Socket 0 CPU Information	Displays the socket specific CPU information.
CPU Power Management	Allows you to enable / disable Turbo Mode.
Active Processor Cores	Enables / Disables the cores in the processor package.
Monitor Mwait	Enables / Disables Monitor Mwait.

### 4.4.7 AMI Graphic Output Protocol Policy

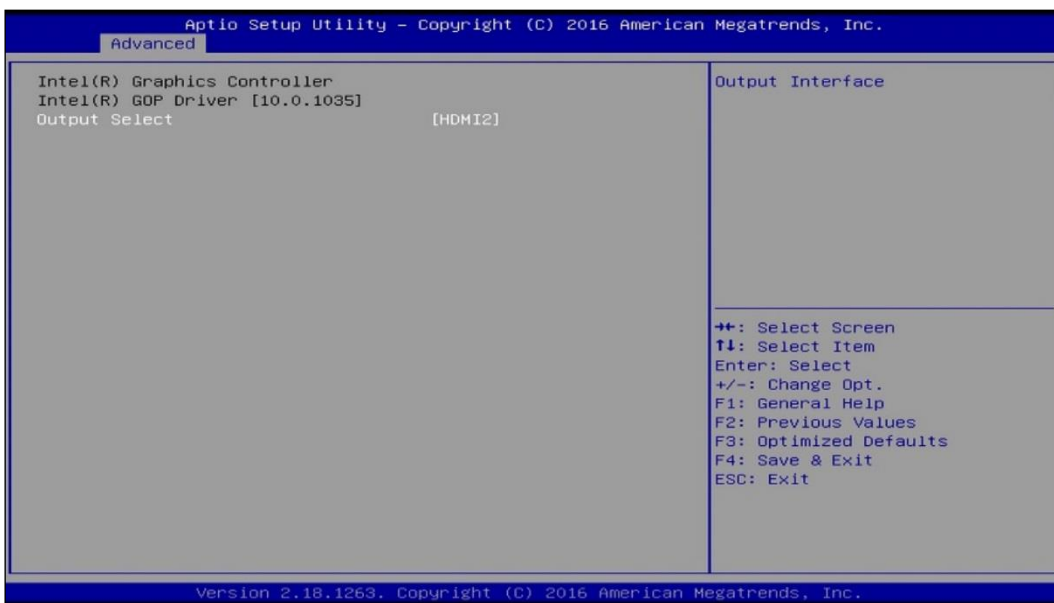

BIOS Setting	Description
Output Select	Outputs through HDMI interface.

### 4.4.8 Network Stack Configuration

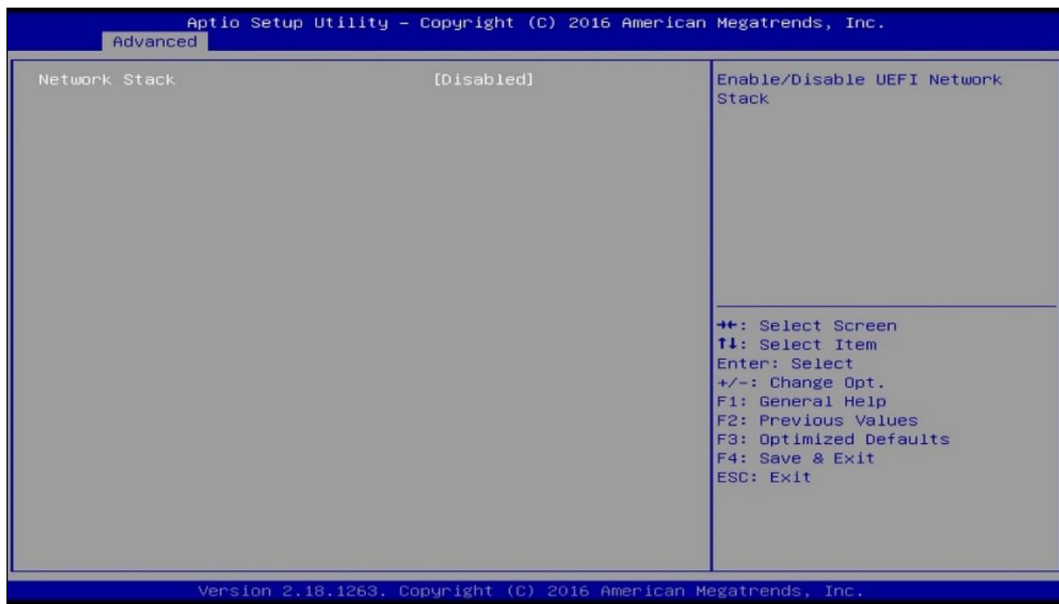

BIOS Setting	Description
Network Stack	Enables / Disables UEFI Network Stack.
IPv4 PXE Support	Enables / Disables IPv4 PXE Boot Support. If disabled, Ipv4 PXE boot option will not be created.
IPv4 HTTP Support	Enables / Disables IPv4 HTTP Boot Support. If disabled, Ipv4 HTTP boot option will not be created.
IPv6 PXE Support	Enables / Disables IPv6 PXE Boot Support. If disabled, Ipv4 PXE boot option will not be created.
IPv6 HTTP Support	Enables / Disables IPv6 HTTP Boot Support. If disabled, Ipv4 HTTP boot option will not be created.
PXE boot wait time	Assigns a period of time to press ESC key to abort the PXE boot.
Media detect count	Assigns a number of times to check the presence of media.

### 4.4.9 CSM Configuration

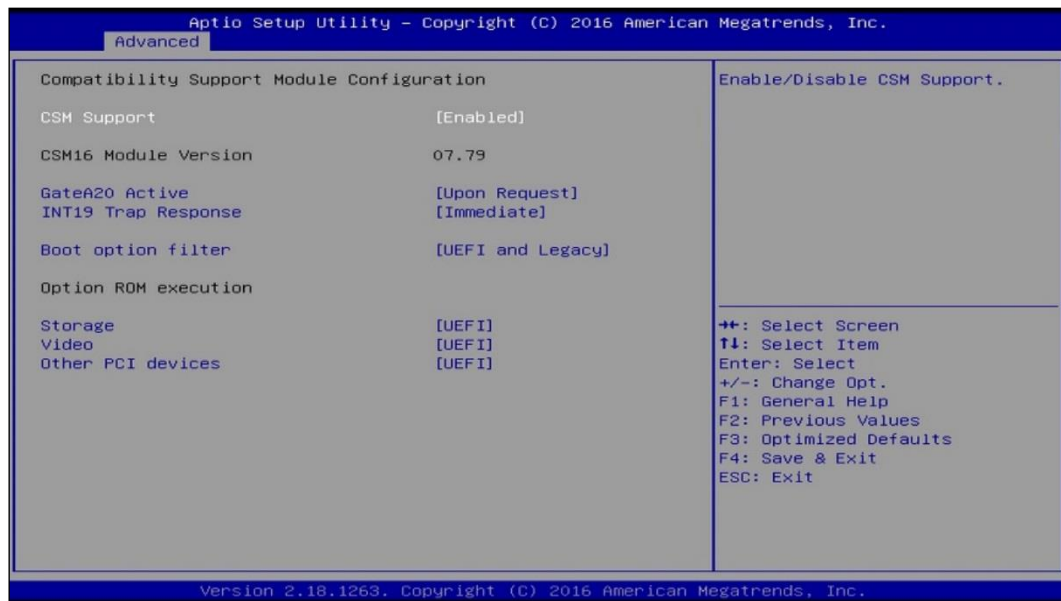

BIOS Setting	Description
CSM Support	Enables / Disables CSM support.
GateA20 Active	<ul style="list-style-type: none"> <li>• <b>Upon Request</b> disables GA20 when using BIOS services.</li> <li>• <b>Always</b> cannot disable GA20, but is useful when any RT code is executed above 1 MB.</li> </ul>
INT19 Trap Response	<p>Sets how BIOS reacts on INT19 trap by Option ROM.</p> <ul style="list-style-type: none"> <li>• <b>Immediate</b> executes the trap right away.</li> <li>• <b>Postponed</b> executes the trap during legacy boot.</li> </ul>
Boot option filter	Controls the priority of Legacy and UEFI ROMs.
Storage	Controls the execution of UEFI and Legacy Storage OpROM.
Video	Controls the execution of UEFI and Legacy Video OpROM.
Other PCI devices	Determines OpROM execution policy for devices other than network, storage or video.

### 4.4.10 USB Configuration

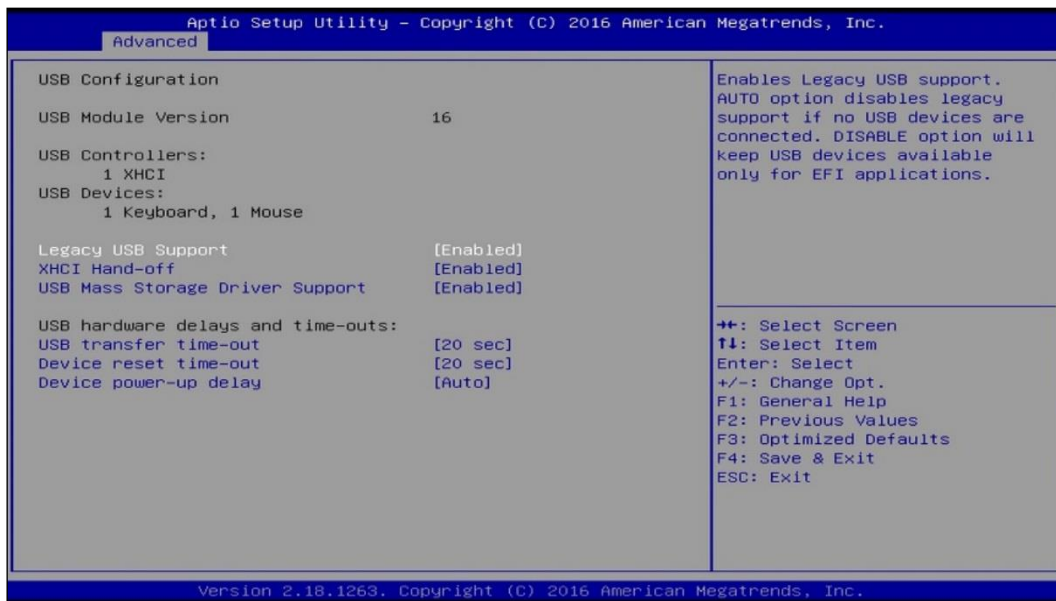

BIOS Setting	Description
Legacy USB Support	<ul style="list-style-type: none"> <li>• <b>Enabled</b> enables Legacy USB support.</li> <li>• <b>Auto</b> disables legacy support if there is no USB device connected.</li> <li>• <b>Disabled</b> keeps USB devices available only for EFI applications.</li> </ul>
XHCI Hand-off	This is a workaround for Oses without XHCI hand-off support. The XHCI ownership change should be claimed by XHCI driver.
USB Mass Storage Driver Support	Enables / Disables the support for USB mass storage driver.
USB Transfer time-out	The time-out value (1 / 5 10 / 20 secs) for Control, Bulk, and Interrupt transfers.
Device reset time-out	Gives seconds (10 / 20 / 30 / 40 secs) to delay execution of Start Unit command to USB mass storage device.
Device power-up delay	The maximum time the device will take before it properly reports itself to the Host Controller. <b>Auto</b> uses default value for a Root port it is 100ms. But for a Hub port, the delay is taken from Hub descriptor.

## 4.5 Chipset Settings

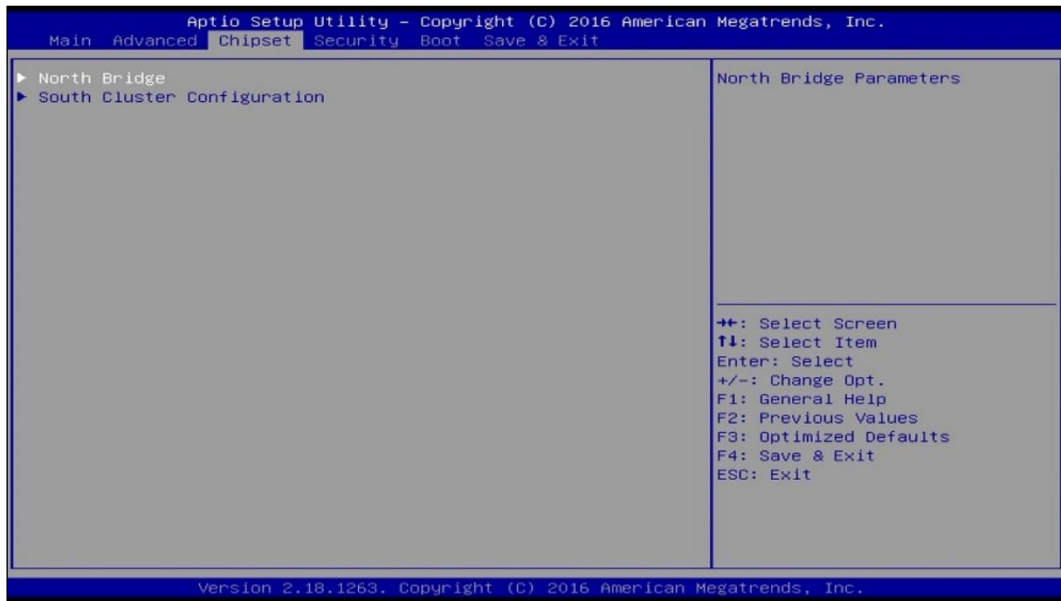

### 4.5.1 North Bridge

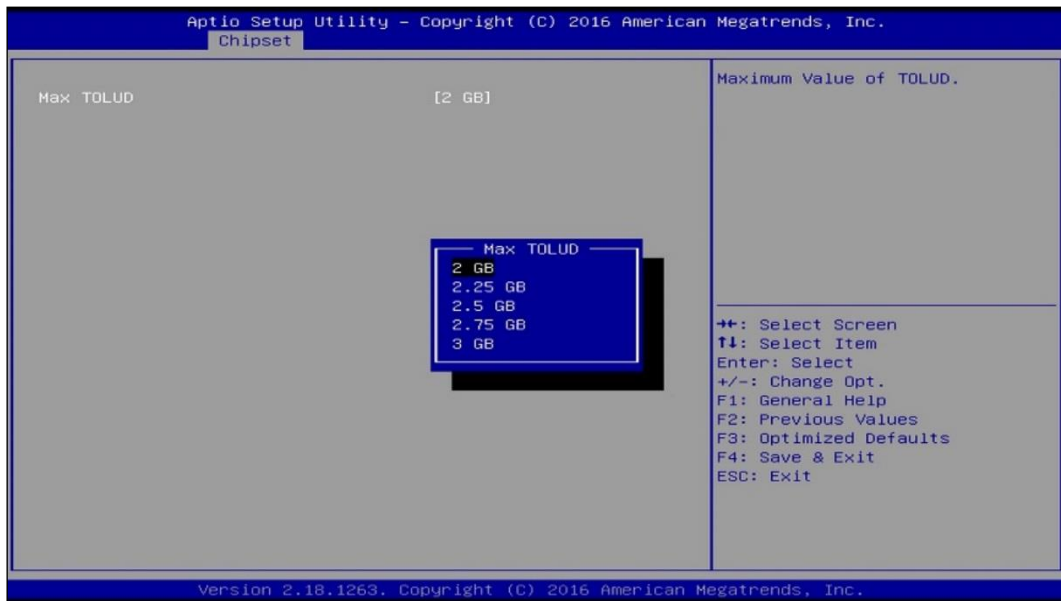

## 4.5.2 South Cluster Configuration

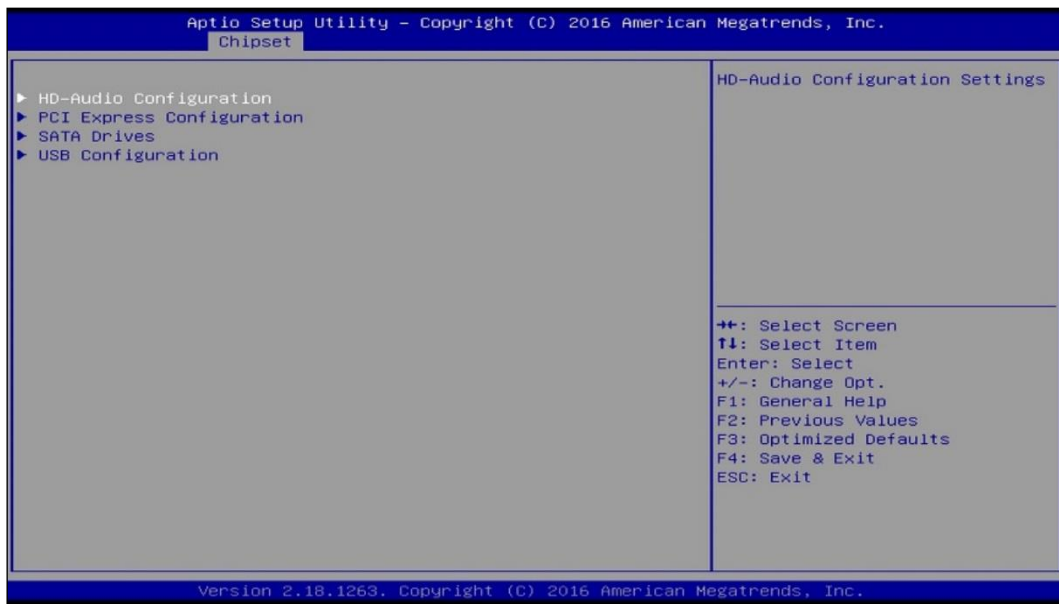

### 4.5.2.1. HD Audio Configuration

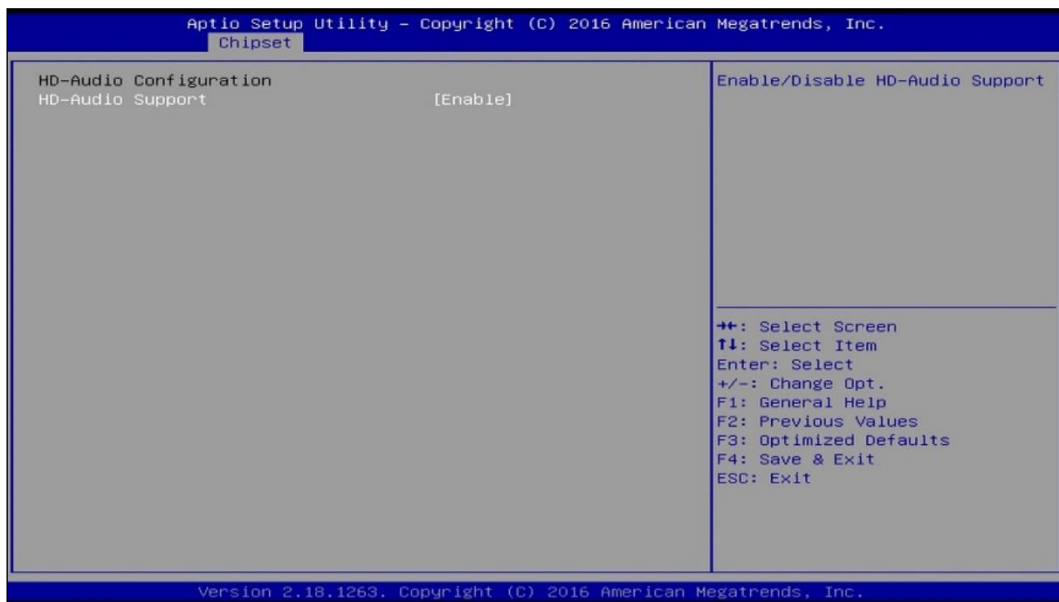

### 4.5.2.2. PCI Express Configuration

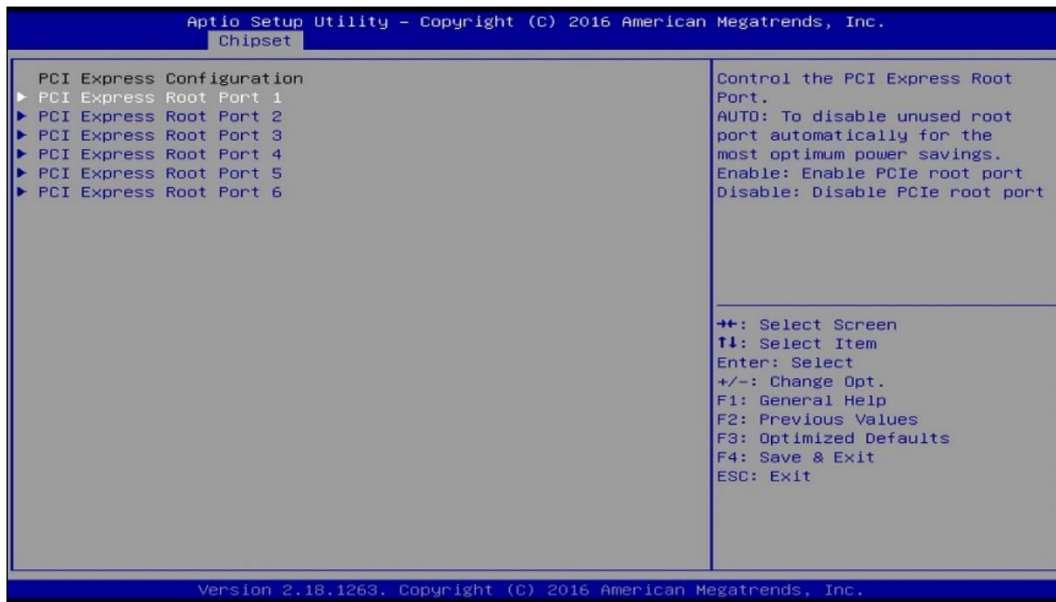

BIOS Setting	Description
PCI Express Root Port 1 ~ 6	Accesses the control of the PCI Express Root Port.

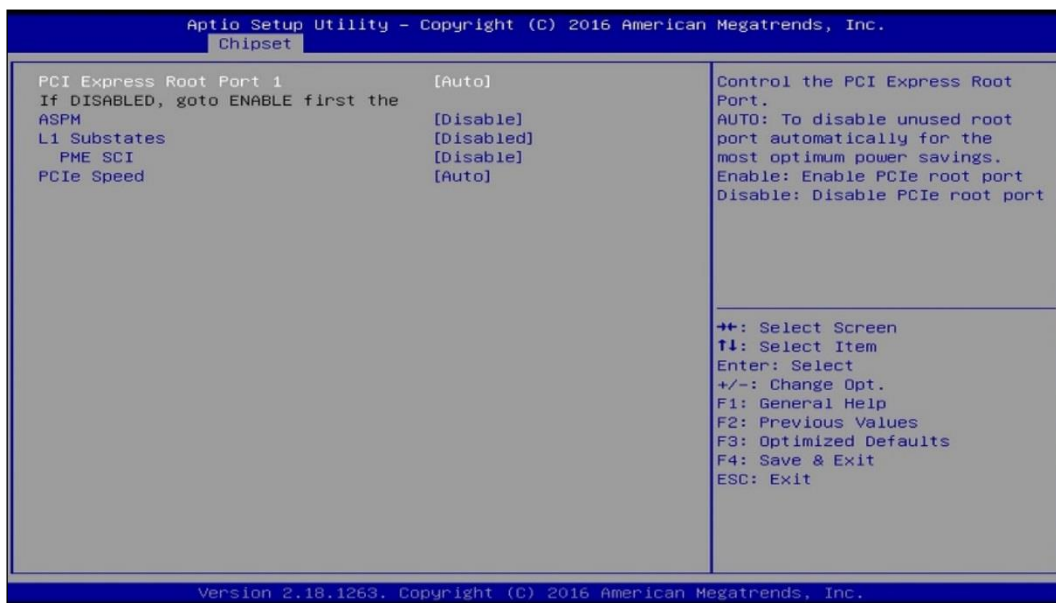

BIOS Setting	Description
PCI Express Root Port	Enables/ Disables the PCIe root port. Auto: To disable unused root port automatically for the most optimum power savings.

BIOS Setting	Description
ASPM	Sets the PCIe active state power management. Options: Disable / L0s / L1 / L0SL1 / Auto
L1 Substates	Sets PCIe L1 substates. Options: Disables / L1.1 / L1.2 / L1.1 & L1.2
PME SCI	Enables / Disables PME SCI.
PCIe Speed	Configures the PCIe speed.

**4.5.2.3. SATA Drivers**

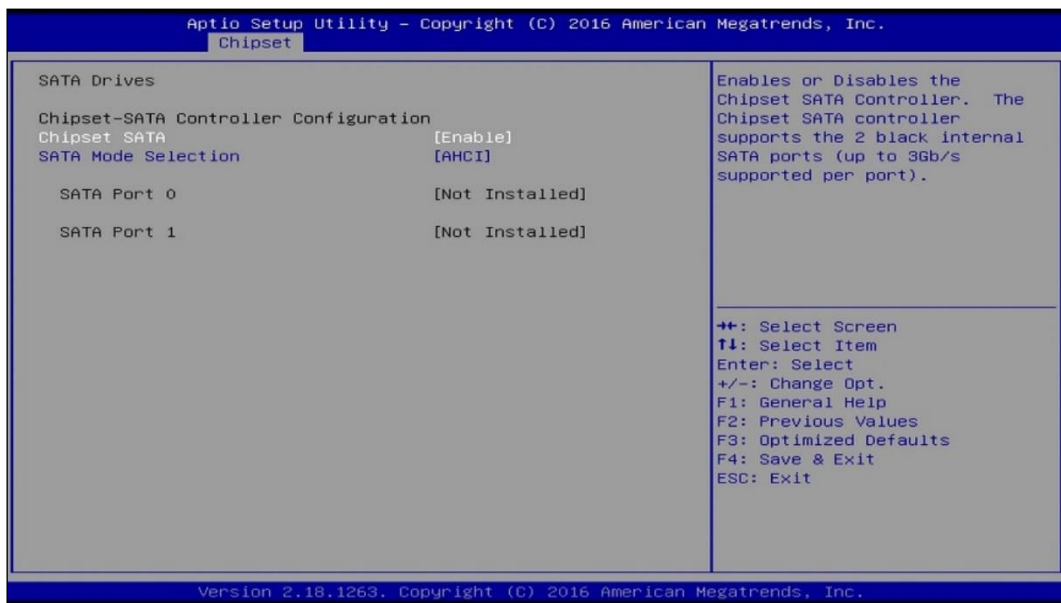

BIOS Setting	Description
Chipset SATA	Enables / Disables the Chipset SATA Controller. The Chipset SATA Controller supports the 2 black internal SATA ports (up to 3Gb/s supported per port).
SATA Mode Selection	Determines how SATA controller(s) operate.

### 4.5.2.4. USB Configuration

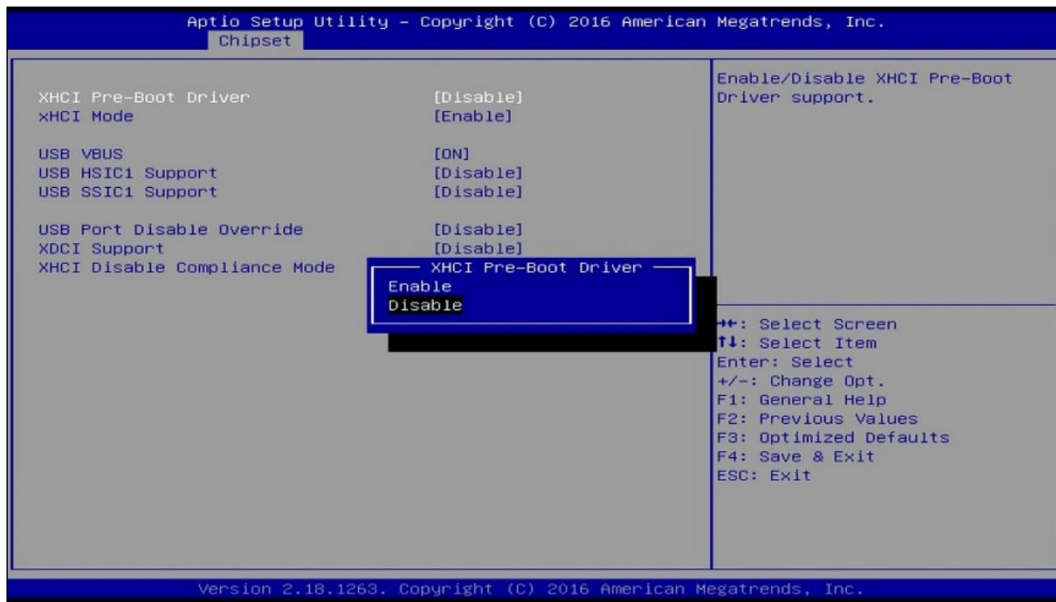

BIOS Setting	Description
XHCI Pre-Boot Driver	Enables / Disables the support for XHCI Pre-Boot Driver.
XHCI Mode	Enables / Disables XHCI mode. If disabled, XHCI controller would be disabled, and none of the USB devices are detectable or usable when system is booted up in OS. Do NOT disable it unless for debug purpose.
USB VBUS	VBUS should be ON in HOST mode. It should be OFF in OTG device mode.
USB HSIC1 Support	Enables / Disables USB HSIC1.
USB SSIC1 Support	Enables / Disables USB SSIC1.
USB Port Disable Override	Selectively enables / disables the corresponding USB port from reporting a device connection to the controller.
XDCI Support	Enables / Disables XDCI.
XHCI Disable Compliance Mode	FALSE makes the XHCI Link Compliance Mode not disabled. TRUE disables the XHCI Link Compliance Mode.

## 4.6 Security Settings

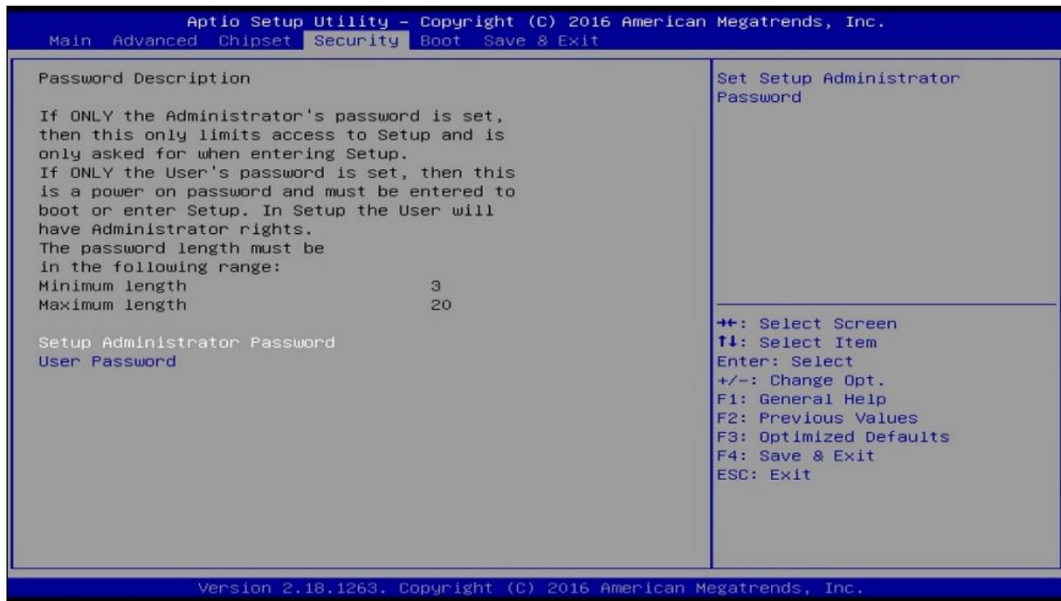

BIOS Setting	Description
Setup Administrator Password	Sets an administrator password for the setup utility.
User Password	Sets a user password.

## 4.7 Boot Settings

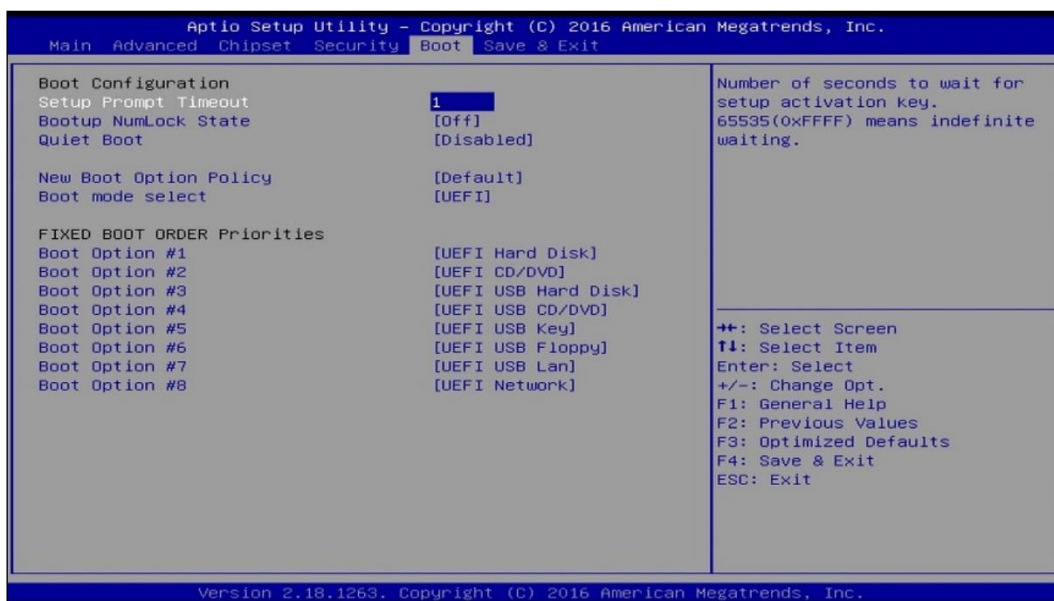

BIOS Setting	Description
Setup Prompt Timeout	Number of seconds to wait for setup activation key. 65535 (0xFFFF) means indefinite waiting.
Bootup NumLock State	Selects the keyboard NumLock state.
Quiet Boot	Enables / Disables Quiet Boot option.
New Boot Option Policy	Controls the placement of newly detected UEFI boot options. Options: Default, Place First, Place Last
Boot mode select	Selects a Boot mode, Legacy / UEFI / Dual.
Boot Option Priorities	Sets the system boot order priorities for hard disk, CD/DVD, USB, Network.

## 4.8 Save & Exit Settings

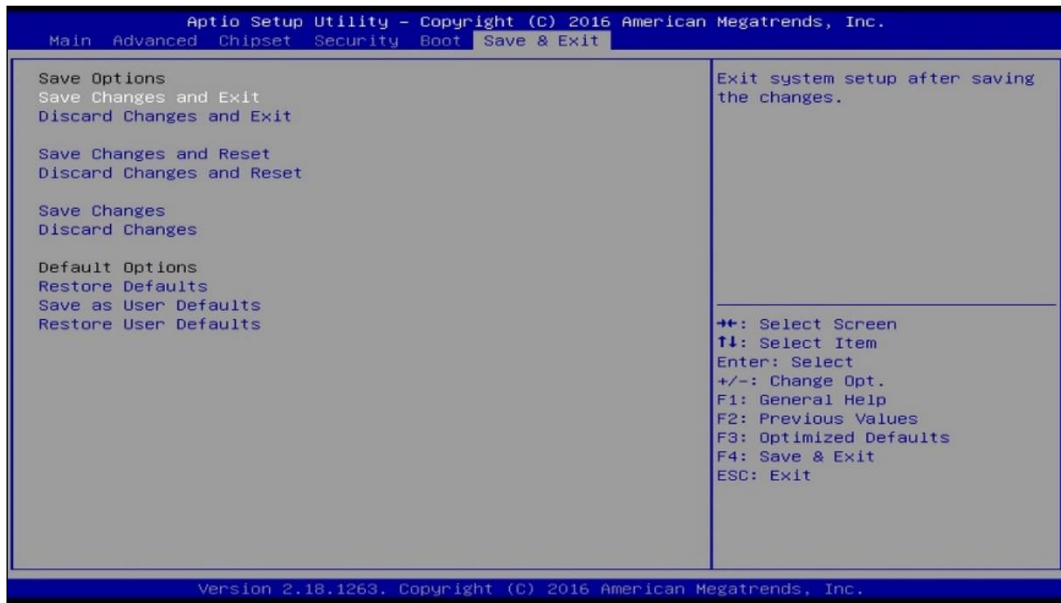

BIOS Setting	Description
Save Changes and Exit	Exits system setup after saving the changes.
Discard Changes and Exit	Exits system setup without saving any changes.
Save Changes and Reset	Resets the system after saving the changes.
Discard Changes and Reset	Resets system setup without saving any changes.
Save Changes	Saves changes done so far to any of the setup options.
Discard Changes	Discards changes done so far to any of the setup options.
Restore Defaults	Restores / Loads defaults values for all the setup options.
Save as User Defaults	Saves the changes done so far as User Defaults.
Restore User Defaults	Restores the user defaults to all the setup options.

## Appendix

This section provides the mapping addresses of peripheral devices and the sample code of watchdog timer configuration.

- I/O Port Address Map
- Interrupt Request Lines (IRQ)
- Watchdog Timer Configuration

## A. I/O Port Address Map

Each peripheral device in the system is assigned a set of I/O port addresses which also becomes the identity of the device. The following table lists the I/O port addresses used.

Address	Device Description
0x00000A00-0x00000A0F	Motherboard resources
0x00000A10-0x00000A1F	Motherboard resources
0x00000A20-0x00000A2F	Motherboard resources
0x0000002E-0x0000002F	Motherboard resources
0x0000004E-0x0000004F	Motherboard resources
0x00000061-0x00000061	Motherboard resources
0x00000063-0x00000063	Motherboard resources
0x00000065-0x00000065	Motherboard resources
0x00000067-0x00000067	Motherboard resources
0x00000070-0x00000070	Motherboard resources
0x00000070-0x00000070	System CMOS/real time clock
0x00000080-0x0000008F	Motherboard resources
0x00000092-0x00000092	Motherboard resources
0x000000B2-0x000000B3	Motherboard resources
0x00000680-0x0000069F	Motherboard resources
0x00000400-0x0000047F	Motherboard resources
0x00000500-0x000005FE	Motherboard resources
0x00000600-0x0000061F	Motherboard resources
0x0000164E-0x0000164F	Motherboard resources
0x0000F040-0x0000F05F	Intel(R) Celeron(R)/Pentium(R) Processor SMBUS - 5AD4
0x0000D000-0x0000DFFF	Intel(R) Celeron(R)/Pentium(R) Processor PCI Express Root Port - 5AD9
0x000003F8-0x000003FF	Communications Port (COM1)
0x000002F8-0x000002FF	Communications Port (COM2)
0x000003E8-0x000003EF	Communications Port (COM3)
0x000002E8-0x000002EF	Communications Port (COM4)

Address	Device Description
0x0000E000-0x0000EFFF	Intel(R) Celeron(R)/Pentium(R) Processor PCI Express Root Port - 5AD8
0x00000000-0x0000006F	PCI Express Root Complex
0x00000078-0x00000CF7	PCI Express Root Complex
0x00000D00-0x0000FFFF	PCI Express Root Complex
0x00000020-0x00000021	Programmable interrupt controller
0x00000024-0x00000025	Programmable interrupt controller
0x00000028-0x00000029	Programmable interrupt controller
0x0000002C-0x0000002D	Programmable interrupt controller
0x00000030-0x00000031	Programmable interrupt controller
0x00000034-0x00000035	Programmable interrupt controller
0x00000038-0x00000039	Programmable interrupt controller
0x0000003C-0x0000003D	Programmable interrupt controller
0x000000A0-0x000000A1	Programmable interrupt controller
0x000000A4-0x000000A5	Programmable interrupt controller
0x000000A8-0x000000A9	Programmable interrupt controller
0x000000AC-0x000000AD	Programmable interrupt controller
0x000000B0-0x000000B1	Programmable interrupt controller
0x000000B4-0x000000B5	Programmable interrupt controller
0x000000B8-0x000000B9	Programmable interrupt controller
0x000000BC-0x000000BD	Programmable interrupt controller
0x000004D0-0x000004D1	Programmable interrupt controller
0x0000F000-0x0000F03F	Intel(R) HD Graphics
0x0000F090-0x0000F097	Standard SATA AHCI Controller
0x0000F080-0x0000F083	Standard SATA AHCI Controller
0x0000F060-0x0000F07F	Standard SATA AHCI Controller
0x00000040-0x00000043	System timer
0x00000050-0x00000053	System timer

## B. Interrupt Request Lines (IRQ)

Peripheral devices use interrupt request lines to notify CPU for the service required. The following table shows the IRQ used by the devices on board.

Level	Function
IRQ 0	System timer
IRQ 3	Communications Port (COM2)
IRQ 4	Communications Port (COM1)
IRQ 4	PCI Data Acquisition and Signal Processing Controller
IRQ 5	Communications Port (COM3)
IRQ 5	PCI Data Acquisition and Signal Processing Controller
IRQ 6	PCI Data Acquisition and Signal Processing Controller
IRQ 7	PCI Data Acquisition and Signal Processing Controller
IRQ 8	High precision event timer
IRQ 10	Communications Port (COM4)
IRQ 14	Intel(R) Serial IO GPIO Host Controller - INT3452
IRQ 25	High Definition Audio Controller
IRQ 35	PCI Data Acquisition and Signal Processing Controller
IRQ 36	PCI Data Acquisition and Signal Processing Controller
IRQ 37	PCI Data Acquisition and Signal Processing Controller
IRQ 39	SDA Standard Compliant SD Host Controller
IRQ 54 ~ 204	Microsoft ACPI-Compliant System
IRQ 256 ~ 511	Microsoft ACPI-Compliant System
IRQ 4294967279	Intel(R) USB 3.0 eXtensible Host Controller - 1.0 (Microsoft)
IRQ 4294967280 ~ IRQ 4294967285	Intel(R) I211 Gigabit Network Connection #2
IRQ 4294967286 ~ IRQ 4294967291	Intel(R) I211 Gigabit Network Connection
IRQ 4294967292	Intel(R) Trusted Execution Engine Interface
IRQ 4294967293	Intel(R) HD Graphics
IRQ 4294967294	Standard SATA AHCI Controller

## C. Watchdog Timer Configuration

The Watchdog Timer (WDT) is used to generate a variety of output signals after a user programmable count. The WDT is suitable for the use in the prevention of system lock-up, such as when software becomes trapped in a deadlock. Under these sorts of circumstances, the timer will count to zero and the selected outputs will be driven.

Under normal circumstance, you will need to restart the WDT at regular intervals before the timer counts to zero.

### Sample Code

```
//-----
//
// THIS CODE AND INFORMATION IS PROVIDED "AS IS" WITHOUT WARRANTY OF ANY
// KIND, EITHER EXPRESSED OR IMPLIED, INCLUDING BUT NOT LIMITED TO THE
// IMPLIED WARRANTIES OF MERCHANTABILITY AND/OR FITNESS FOR A
// PARTICULAR
// PURPOSE.
//
//-----
#include <dos.h>
#include <conio.h>
#include <stdio.h>
#include <stdlib.h>
#include "F81964.H"
//-----
int main (int argc, char *argv[]);
void EnableWDT(int);
void DisableWDT(void);
//-----
int main (int argc, char *argv[])
{
    unsigned char bBuf;
    unsigned char bTime;
    char **endptr;

    char SIO;

    printf("Fintek 81964 watch dog program\n");
    SIO = Init_F81964();
    if (SIO == 0)
    {
        printf("Can not detect Fintek 81964, program abort.\n");
        return(1);
    }//if (SIO == 0)

    if (argc != 2)
    {
```

```

        printf(" Parameter incorrect!!\n");
        return (1);
    }

    bTime = strtol (argv[1], endptr, 10);
    printf("System will reset after %d seconds\n", bTime);

    if (bTime)
    { EnableWDT(bTime); }
    else
    { DisableWDT(); }
    return 0;
}
//-----
void EnableWDT(int interval)
{
    unsigned char bBuf;

    bBuf = Get_F81964_Reg(0x2B);
    bBuf &= (~0x20);
    Set_F81964_Reg(0x2B, bBuf); //Enable WDTO

    Set_F81964_LD(0x07); //switch to logic device 7
    Set_F81964_Reg(0x30, 0x01); //enable timer

    bBuf = Get_F81964_Reg(0xF5);
    bBuf &= (~0x0F);
    bBuf |= 0x52;
    Set_F81964_Reg(0xF5, bBuf); //count mode is second

    Set_F81964_Reg(0xF6, interval); //set timer

    bBuf = Get_F81964_Reg(0xFA);
    bBuf |= 0x01;
    Set_F81964_Reg(0xFA, bBuf); //enable WDTO output

    bBuf = Get_F81964_Reg(0xF5);
    bBuf |= 0x20;
    Set_F81964_Reg(0xF5, bBuf); //start counting
}
//-----
void DisableWDT(void)
{
    unsigned char bBuf;

    Set_F81964_LD(0x07); //switch to logic device 7

    bBuf = Get_F81964_Reg(0xFA);
    bBuf &= ~0x01;
    Set_F81964_Reg(0xFA, bBuf); //disable WDTO output

    bBuf = Get_F81964_Reg(0xF5);
    bBuf &= ~0x20;
    bBuf |= 0x40;
}

```

```

        Set_F81964_Reg(0xF5, bBuf); //disable WDT
    }
//-----

//-----
//
// THIS CODE AND INFORMATION IS PROVIDED "AS IS" WITHOUT WARRANTY OF ANY
// KIND, EITHER EXPRESSED OR IMPLIED, INCLUDING BUT NOT LIMITED TO THE
// IMPLIED WARRANTIES OF MERCHANTABILITY AND/OR FITNESS FOR A
// PARTICULAR
// PURPOSE.
//
//-----
#include "F81964.H"
#include <dos.h>
//-----
unsigned int F81964_BASE;
void Unlock_F81964 (void);
void Lock_F81964 (void);
//-----
unsigned int Init_F81964(void)
{
    unsigned int result;
    unsigned char ucDid;

    F81964_BASE = 0x4E;
    result = F81964_BASE;

    ucDid = Get_F81964_Reg(0x20);
    if (ucDid == 0x07) //Fintek 81964
    { goto Init_Finish; }

    F81964_BASE = 0x2E;
    result = F81964_BASE;

    ucDid = Get_F81964_Reg(0x20);
    if (ucDid == 0x07) //Fintek 81964
    { goto Init_Finish; }

    F81964_BASE = 0x00;
    result = F81964_BASE;

Init_Finish:
    return (result);
}
//-----
void Unlock_F81964 (void)
{
    outportb(F81964_INDEX_PORT, F81964_UNLOCK);
    outportb(F81964_INDEX_PORT, F81964_UNLOCK);
}
//-----
void Lock_F81964 (void)

```

```
{
    outportb(F81964_INDEX_PORT, F81964_LOCK);
}
//-----
void Set_F81964_LD( unsigned char LD)
{
    Unlock_F81964();
    outportb(F81964_INDEX_PORT, F81964_REG_LD);
    outportb(F81964_DATA_PORT, LD);
    Lock_F81964();
}
//-----
void Set_F81964_Reg( unsigned char REG, unsigned char DATA)
{
    Unlock_F81964();
    outportb(F81964_INDEX_PORT, REG);
    outportb(F81964_DATA_PORT, DATA);
    Lock_F81964();
}
//-----
unsigned char Get_F81964_Reg(unsigned char REG)
{
    unsigned char Result;
    Unlock_F81964();
    outportb(F81964_INDEX_PORT, REG);
    Result = inportb(F81964_DATA_PORT);
    Lock_F81964();
    return Result;
}
//-----

//-----
//
// THIS CODE AND INFORMATION IS PROVIDED "AS IS" WITHOUT WARRANTY OF ANY
// KIND, EITHER EXPRESSED OR IMPLIED, INCLUDING BUT NOT LIMITED TO THE
// IMPLIED WARRANTIES OF MERCHANTABILITY AND/OR FITNESS FOR A
// PARTICULAR
// PURPOSE.
//
//-----
#ifndef F81964_H
#define F81964_H    1
//-----
#define F81964_INDEX_PORT (F81964_BASE)
#define F81964_DATA_PORT (F81964_BASE+1)
//-----
#define F81964_REG_LD    0x07
//-----
#define F81964_UNLOCK    0x87
#define F81964_LOCK    0xAA
//-----
```

```
unsigned int Init_F81964(void);  
void Set_F81964_LD( unsigned char);  
void Set_F81964_Reg( unsigned char,  
unsigned char); unsigned char  
Get_F81964_Reg( unsigned char);  
//-----  
#endif // F81964_H
```