

FWA8206 Series  
Network Appliance

**User's Manual**

Version: 1.0

## Table of Contents

<b>Chapter 1</b>	<b>Introduction</b> .....	<b>3</b>
<b>Chapter 2</b>	<b>System Specification</b> .....	<b>4</b>
<b>Chapter 3</b>	<b>Hardware Configuration</b> .....	<b>5</b>
<b>Chapter 4</b>	<b>Console Mode Information</b> .....	<b>7</b>
<b>Chapter 5</b>	<b>Opening the chassis</b> .....	<b>9</b>
<b>Chapter 6</b>	<b>Removing and Installing DIMM</b> .....	<b>10</b>
<b>Chapter 7</b>	<b>Removing and Installing CompactFlash Card</b> .....	<b>11</b>
<b>Chapter 8</b>	<b>Removing and Installing the Battery</b> .....	<b>12</b>
<b>Chapter 9</b>	<b>Installing the 3.5" HDD</b> .....	<b>13</b>
<b>Chapter 10</b>	<b>Installing the 2.5" HDD</b> .....	<b>14</b>
<b>Chapter 11</b>	<b>BIOS Information</b> .....	<b>15</b>
<b>Chapter 12</b>	<b>Bypass Information</b> .....	<b>28</b>
<b>Chapter 13</b>	<b>Factory Default Information</b> .....	<b>31</b>
<b>Chapter 14</b>	<b>GPO LED Information</b> .....	<b>33</b>
<b>Chapter 15</b>	<b>System Architecture</b> .....	<b>36</b>

## Foreword

To prevent damage to the system board, please handle it with care and follow the measures below, which are generally sufficient to protect your equipment from static electricity discharge:

When handling the board, use a grounded wrist strap designed for static discharge elimination grounded to a metal object before removing the board from the antistatic bag. Handle the board by its edges only; do not touch its components, peripheral chips, memory modules or gold contacts.

When handling processor chips or memory modules, avoid touching their pins or gold edge fingers. Return the Network Appliance system board and peripherals back into the antistatic bag when not in use or not installed in the chassis.

Some circuitry on the system board can continue to operate even though the power is switched off. Under no circumstances should the Lithium battery cell used to power the real-time clock be allowed to be shorted. The battery cell may heat up under these conditions and present a burn hazard.

### **WARNING!**

1. "CAUTION: DANGER OF EXPLOSION IF BATTERY IS INCORRECTLY REPLACED.  
REPLACE ONLY WITH SAME OR EQUIVALENT TYPE RECOMMENDED BY THE  
MANUFACTURER. DISCARD USED BATTERIES ACCORDING TO THE  
MANUFACTURER'S INSTRUCTIONS"
2. This guide is for technically qualified personnel who have experience installing and configuring system boards. Disconnect the system board power supply from its power source before you connect/disconnect cables or install/remove any system board components. Failure to do this can result in personnel injury or equipment damage.
3. Avoid short-circuiting the lithium battery; this can cause it to superheat and cause burns if touched.
4. Do not operate the processor without a thermal solution. Damage to the processor can occur in seconds.
5. Do not block air vents at least minimum 1/2-inch clearance required.

## Chapter 1 Introduction

The FWA8206 series was specifically designed for the network security & management market.

Network Security Applications:

- Firewall
- Virtual Private Network
- Proxy Server
- Caching Server

Network Management Applications:

- Load balancing
- Quality of Service
- Remote Access Service

The FWA network appliance product line covers the spectrum from offering platforms designed for :

- SOHO
- SMB
- Enterprise

Each product is designed to address the distinctive requirements of its respective market segment from cost effective entry-level solutions to high throughput and performance-bound systems for the Enterprise level.

## Chapter 2 System Specification

Project Name	FWA8206
Construction	19" 1U Rackmount
Processor	Intel® Core 2 Quad / Core 2 Duo / Core 2 Extreme Conroe, Conroe-L, Conroe XE, Allendale, Wolfdale, Kentsfield, Kentsfield XE, Yorkfield XE processors. With FSB 800/1066/1333 MHz
Memory	Support DDR2 667/800 SDRAM, up to 8GB
Chipset	North Bridge : Intel Q35 South Bridge : Intel ICH9 I/O Controller Hub
Ethernet	Onboard: Intel® 82574L Gigabit Ethernet controllers x6 with RJ-45 connector Eth0 & Eth1 with hardware Bypass  Expansion LAN module: Intel® 82541PI Gigabit Ethernet controllers x2 with RJ-45 connector
Expansion slots	PCI expansion slot x2
Storages	Support 3.5" SATA HDD x1 , CF card x1 , DOM x1
Front I/O	USB 2.0 ports x 2 DB-9 x 1 for Console Power LED HDD Access LED Bypass LED GPO LED ID1~5 Factory Default switch Reset switch Support LCM/Key pad module (IBASE proprietary)
Hardware Monitor	Voltage, Temperature
Power Supply	300W ATX, Full Range
Dimensions	44 mm (H) x 430 mm (W) x 411mm (D)
Operating Environment	Temperature : 0 ~ 40°C Humidity : 20% ~ 90%
Storage Environment	Temperature : 0 ~ 70°C Humidity : 5% ~ 95%

## Chapter 3 Hardware Configuration

### CPU board layout

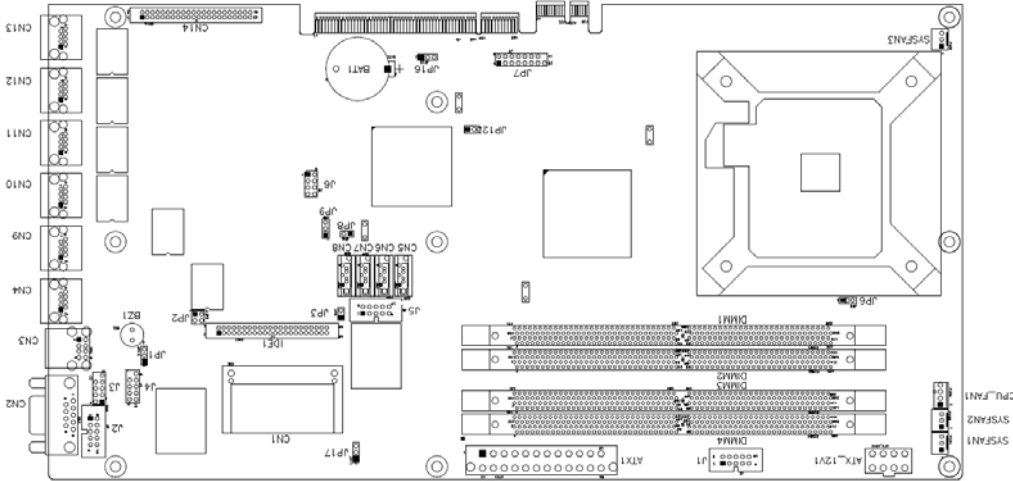

### Jumper Setting

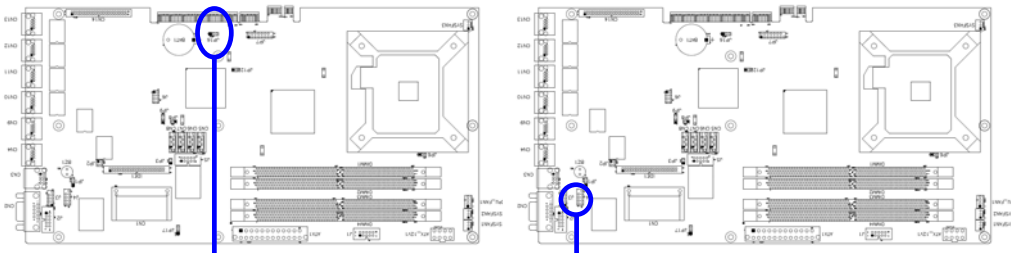

JP16: Clear CMOS Contents  
JP16:1-2 Normal (Default)

2-3 Clear CMOS

JP1, JP2: Watchdog Timer & LAN1/LAN2 Bypass Settings  
JP1 & JP2 : **JP2 Pin 1-2 & 3-4 Open JP1 Pin 1-2 Closed**  
System will bypass LANs upon the time out of watchdog timer

JP1 & JP2 : JP2 Pin 1-2 & 3-4 Open JP1 Pin 2-3 Closed  
System LANs bypass function controlled by SIO GPIO15.

JP1 & JP2 : JP2 Pin 1-2 & 3-4 Closed JP1 Pin 1-2 Closed (Default)  
System will reboot upon the time out of watchdog timer.

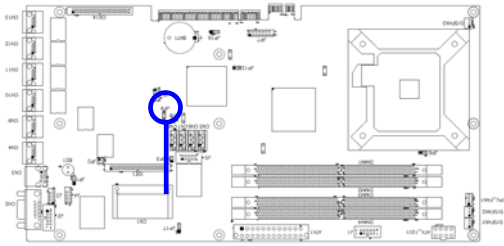

**JP9 : Configure and Recovery (Factory use only)**  
 Pin 1-2 Short/Closed: Normal (default)  
 Pin 2-3 Short/Closed: Configure  
 Open: Recovery

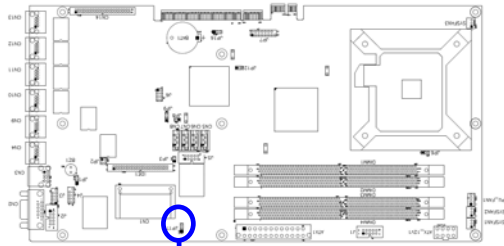

**JP17:Power ON Setting**  
 Pin 1-2 Short/Closed: Power on by power supply AC on  
 Pin 2-3 Short/Closed: Power on by system button

## Rear Panel Features



## Front Panel Features

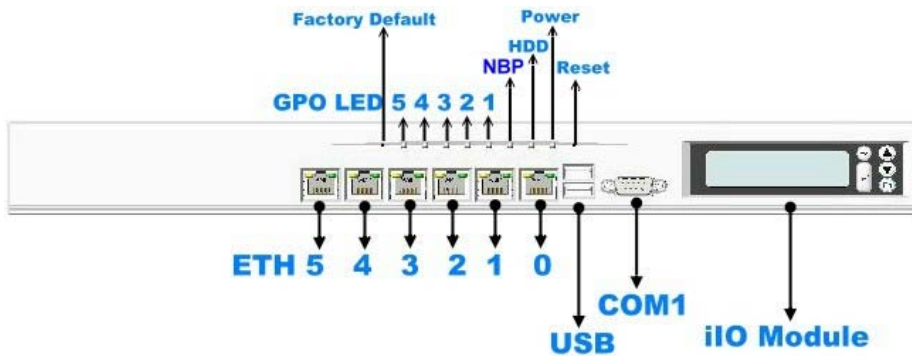

Note :  
 The NBP LED means **None ByPass** function.  
 If NBP LED turns on, it indicates **Normal** mode.  
 If NBP LED turns off, it indicates **Bypass** mode.

## Chapter 4 Console Mode Information

FWA8206 supports output information via Console in BIOS level.

Prepare a computer as client loaded with an existing OS such Windows XP.

Connect client computer and FWA8206 with NULL Modem cable.

Follow the steps below to configure the Windows Hyper Terminal application setting:

1. For executing the Hyper Terminal, issue command "hypertrm".
2. Customize your name for the new connection.



3. Choose the COM port on the client computer for the connection.



4. Please make the port settings to Baud rate 19200, Parity None, Data bits 8, Stop bits 1

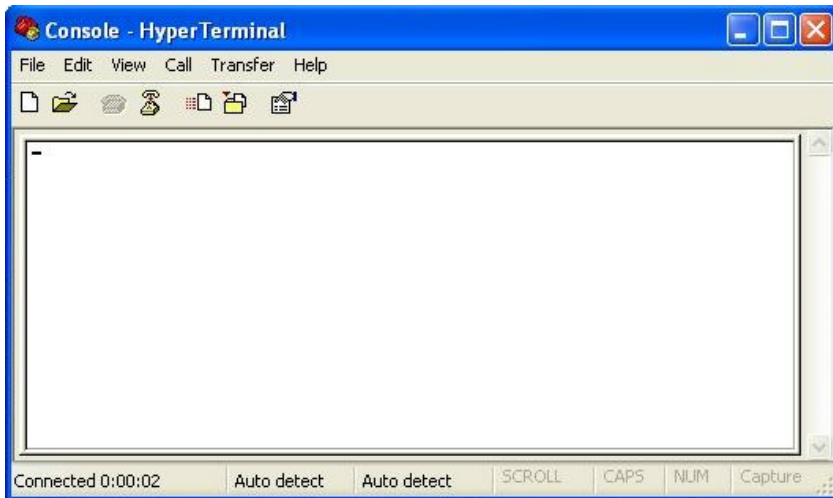

5. Power up the FWA8206, and the screen will display the following information.

```
Phoenix - AwardBIOS v6.00PG, An Energy Star Ally
Copyright (C) 1984-2003, Phoenix Technologies, LTD

(6A79DILB) EVALUATION ROM - NOT FOR SALE

Main Processor : Intel(R) Pentium(R) 4 CPU 2.80GHz(200x14.0)
Memory Testing : 2088960K OK + 8M shared memory
CPU Brand Name : Intel(R) Pentium(R) 4 CPU 2.80GHz

Hyper-Threading Technology CPU Detected (Hyper-Threading Technology Enabled)

Memory Frequency For DDR 333 (Dual Channel Mode Enabled)
IDE Channel 0 Master : None
IDE Channel 0 Slave : None

IDE Channel 2 Master : ST3160023AS 3.18
IDE Channel 2 Slave : None
IDE Channel 3 Master : None
IDE Channel 3 Slave : None

Press DEL/TAB(console) to enter SETUP
```

6. Press **<Tab>** key to enter BIOS setup screen in **Console mode**.  
Press **<Del>** key to enter BIOS setup screen in **VGA mode**.

1. Loosen the two screws of the chassis on the back to remove the top lead (**Fig. 5-1**).



**Fig. 5-1** Take off screws

2. The top lead (**Fig. 5-2**) can be removed from the base stand (**Fig. 5-3**).



**Fig. 5-2** The top lead



**Fig. 5-3** The base stand

## Chapter 6 Removing and Installing DIMM

Follow these steps to upgrade RAM module:

1. Install the system memory by pulling the socket's arm and pressing it into the slot gently. (Fig. 6-1, 6-2)

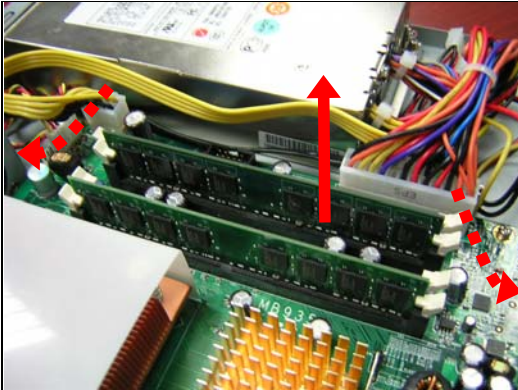

Fig. 6-1 Eject a DIMM module

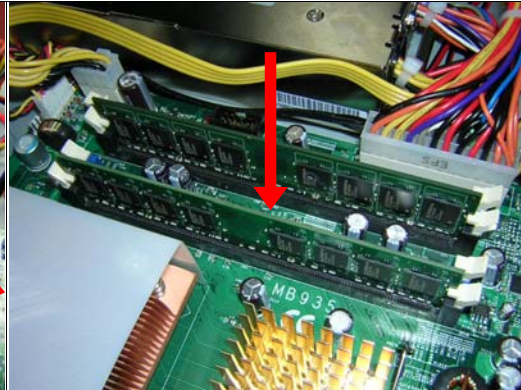

Fig. 6-2 Install DIMM

### Note:

1. FWA8206 series support two groups of dual channels memory. One group is on the black DIMM sockets and the other one is on the blue DIMM sockets. (Fig. 6-3)
2. If you would like to upgrade the memory modules, we suggest the height of memory modules don't exceed 30mm.

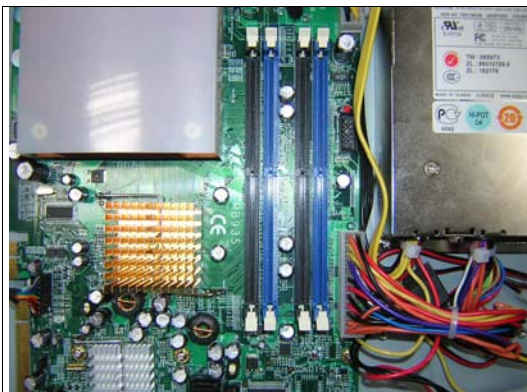

Fig. 6-3 DIMM sockets

## Chapter 7 Removing and Installing CompactFlash Card

1. Insert the Compact Flash Card (**Fig. 7-1**) into the CF interface (**Fig. 7-2**).



**Fig. 7-1** Compact Flash Card

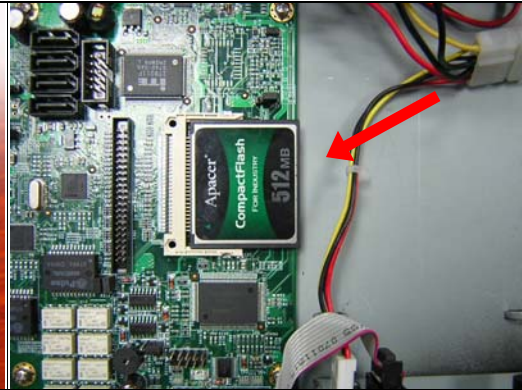

**Fig. 7-2** Insert Compact Flash Card into the CF interface

- 3-2.** The completed installation of CompactFlash Card is shown in **Fig. 7-3**.

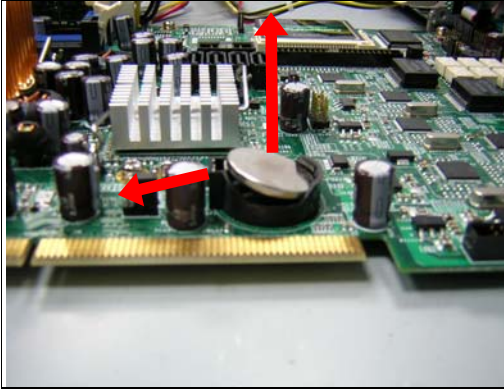

**Fig. 7-3** Completion of Compact Flash Card connection

← 格式化: 項目符號及編號

## Chapter 8 Removing and Installing the Battery

1. Press the metal clip back to eject the button battery (**Fig. 8-1**).
2. Replace it with a new one by pressing the battery with fingertip to restore the battery (**Fig. 8-2**).



**Fig. 8-1** Eject the battery

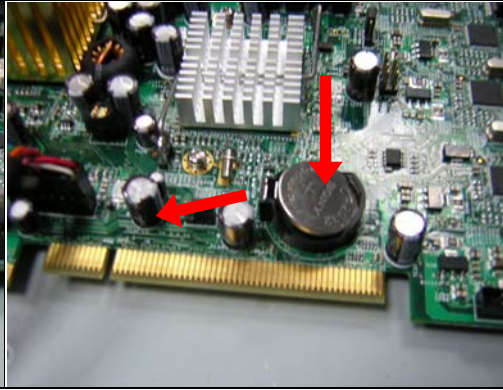

**Fig. 8-2** Restore the battery

## Chapter 9 Installing the 3.5" HDD

Follow the steps below to install the 3.5" HDD:

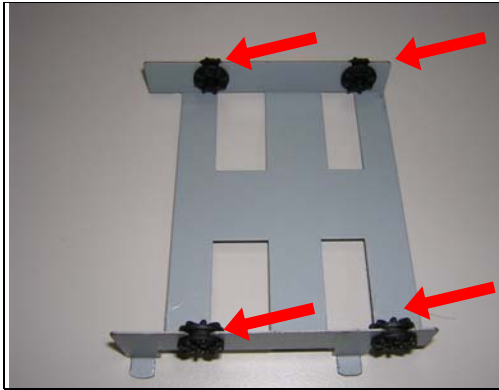

**Fig. 9-1** Push the four shock-absorbent pads to fasten HDD bracket.



**Fig. 9-2** Fasten the four screws to lock HDD and bracket together.



**Fig. 9-3** Connect SATA cable and power connector to 3.5" HDD



**Fig. 9-4** Connect SATA cable to MB935



**Fig. 9-5** Fixed HDD bracket and Fix two screws back

## Chapter 10 Install 2.5" HDD

Follow the steps below to install the 2.5" HDD:

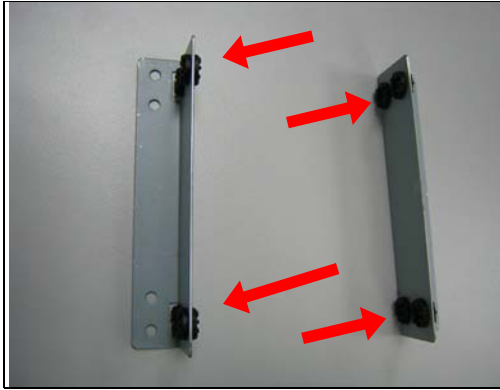

**Fig. 10-1** Push the eight shock-absorbent pads to fasten HDD bracket.



**Fig. 10-2** Fasten the four screws to lock 2.5" HDD bracket and bracket together.



**Fig. 10-3** Fasten the four screws to lock 2.5" HDD and bracket together.

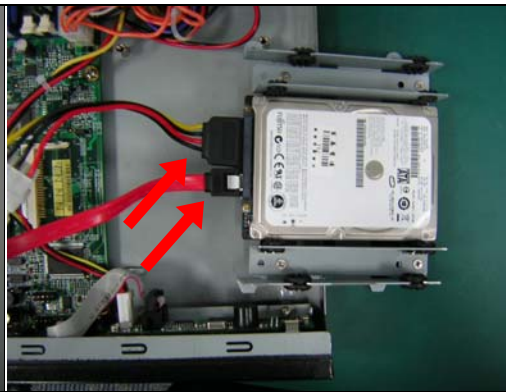

**Fig. 10-4** Connect SATA cable and power connector to 2.5" HDD

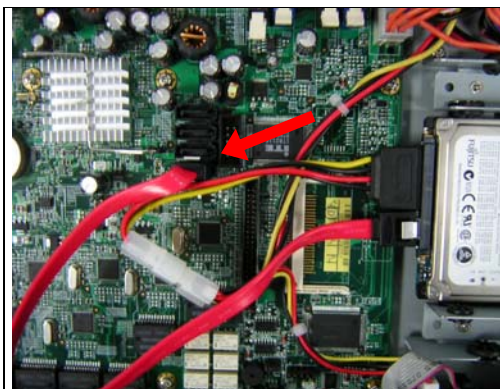

**Fig. 10-5** Connect SATA cable to MB935



**Fig. 10-6** Fixed HDD bracket and Fix two screws back

## Chapter 11 BIOS Information

### Phoenix - AwardBIOS CMOS Setup Utility

Standard CMOS Features	Frequency/Voltage Control
Advanced BIOS Features	Load Fail-Safe Defaults
Advanced Chipset Features	Load Optimized Defaults
Integrated Peripherals	Set Supervisor Password
Power Management Setup	Set User Password
PnP/PCI Configurations	Save & Exit Setup
PC Health Status	Exit Without Saving
ESC : Quit	↑ ↓ → ← : Select Item
F10 : Save & Exit Setup	
Time, Date, Hard Disk Type...	

The section below the setup items of the Main Menu displays the control keys for this menu. At the bottom of the Main Menu just below the control keys section, there is another section, which displays information on the currently highlighted item in the list.

**Note:** *If the system cannot boot after making and saving system changes with Setup, the Award BIOS supports an override to the CMOS settings that resets your system to its default.*

**Warning** *It is strongly recommended that you avoid making any changes to the chipset defaults. These defaults have been carefully chosen by both Award and your system manufacturer to provide the absolute maximum performance and reliability. Changing the defaults could cause the system to become unstable and crash in some cases.*

### Standard CMOS Setup

“Standard CMOS Setup” choice allows you to record some basic hardware configurations in your computer system and set the system clock and error handling. If the motherboard is already installed in a working system, you will not need to select this option. You will need to run the Standard CMOS option, however, if you change your system hardware configurations, the onboard battery fails, or the configuration stored in the CMOS memory was lost or damaged.

### Phoenix - AwardBIOS CMOS Setup Utility Standard CMOS Features

		Item Help
Date (mm:dd:yy)	Thu, May 21, 2001	Menu Level
Time (hh:mm:ss)	00 : 00 : 00	
IDE Channel 0 Master	None	Change the day, month, Year and century
IDE Channel 0 Slave	None	
IDE Channel 1 Master	None	
IDE Channel 1 Slave	None	
Video	EGA/VGA	
Halt On	All Errors	
Base Memory	640K	
Extended Memory	129024K	
Total Memory	130048K	

At the bottom of the menu are the control keys for use on this menu. If you need any help in each item field, you

can press the <F1> key. It will display the relevant information to help you. The memory display at the lower right-hand side of the menu is read-only. It will adjust automatically according to the memory changed. The following describes each item of this menu.

#### Date

The date format is:

**Day :** Sun to Sat  
**Month :** 1 to 12  
**Date :** 1 to 31  
**Year :** 1994 to 2079

To set the date, highlight the "Date" field and use the PageUp/ PageDown or +/- keys to set the current time.

#### Time

The time format is:

**Hour :** 00 to 23  
**Minute :** 00 to 59  
**Second :** 00 to 59

To set the time, highlight the "Time" field and use the <PgUp>/ <PgDn> or +/- keys to set the current time.

#### IDE Primary HDDs / IDE Secondary HDDs

The onboard PCI IDE connectors provide Primary and Secondary channels for connecting up to four IDE hard disks or other IDE devices. Each channel can support up to two hard disks; the first is the "Master" and the second is the "Slave".

Press <Enter> to configure the hard disk. The selections include Auto, Manual, and None. Select 'Manual' to define the drive information manually. You will be asked to enter the following items.

**CYLS :** Number of cylinders  
**HEAD :** Number of read/write heads  
**PRECOMP :** Write precompensation  
**LANDZ :** Landing zone  
**SECTOR :** Number of sectors

The Access Mode selections are as follows:

Auto  
Normal(HD < 528MB)  
Large (for MS-DOS only)  
LBA (HD > 528MB and supports Logical Block Addressing)

#### Video

This field selects the type of video display card installed in your system. You can choose the following video display cards:

EGA/VGA For EGA, VGA, SEGA, SVGA or PGA monitor adapters. (default)  
CGA 40 Power up in 40 column mode.  
CGA 80 Power up in 80 column mode.  
MONO For Hercules or MDA adapters.

#### Halt On

This field determines whether or not the system will halt if an error is detected during power up.

No errors The system boot will not be halted for any error that may be detected.  
All errors Whenever the BIOS detects a non-fatal error, the system will stop and you will be prompted.  
All, But Keyboard The system boot will not be halted for a keyboard error; it will stop for all other errors  
All, But Diskette The system boot will not be halted for a disk error; it will stop for all other errors.  
All, But Disk/Key The system boot will not be halted for a key- board or disk error; it will stop for all others.

#### Advanced BIOS Features

This section allows you to configure and improve your system and allows you to set up some system features according to your preference.

Phoenix - AwardBIOS CMOS Setup Utility  
Advanced BIOS Features

CPU Feature	Press Enter	ITEM HELP
Hard Disk Boot Priority	Press Enter	Menu Level
Virus Warning	Disabled	
CPU L1 and L2 Cache	Enabled	
CPU L3 Cache	Enabled	
Hyper-threading Technology	Enabled	
Quick Power On Self Test	Enabled	
First Boot Device	USB-FDD	Select Hard Disk Boot Device Priority
Second Boot Device	Hard Disk	
Third Boot Device	LAN	
Boot Other Device	Enabled	
Boot Up Numlock Status	On	
Gate A20 Option	Fast	
Typematic Rate Setting	Disabled	
Typematic Rate (chars/Sec)	6	
Typematic Delay (Msec)	250	
Security Option	Setup	
APIC Mode	Enabled	
MPS Version Control for OS	1.4	
OS Select For DRAM>64MB	Non-OS2	
Console Redirection	Enable	
Baud Rate	19200	
Agent connect via	NULL	
Agent wait time(min)	1	
Agent after boot	Disabled	
Report No FDD For WIN 95	Yes	
Small Logo (EPA) Show	Enabled	

**Hard Disk Boot Priority**

This item allows you to set the priority for hard disk boot. When you press enter, the selections shows the current hard disks used in your system as well as the "Bootable Add-in Card" that is relevant to other boot sources media such as SCSI cards and LAN cards.

**CPU L1 and L2 Cache**

Cache memory is additional memory that is much faster than conventional DRAM (system memory). CPUs from 486-type on up contain internal cache memory, and most, but not all, modern PCs have additional (external) cache memory. When the CPU requests data, the system transfers the requested data from the main DRAM into cache memory, for even faster access by the CPU. These items allow you to enable (speed up memory access) or disable the cache function. By default, these items are Enabled.

**Hyper-Threading Technology**

This feature is enabled when your processor supports Hyper-Threading Technology. Otherwise, this field will be hidden.

**Quick Power On Self Test**

When enabled, this field speeds up the Power On Self Test (POST) after the system is turned on. If it is set to *Enabled*, BIOS will skip some items.

**First/Second/Third Boot Device**

These fields determine the drive that the system searches first for an operating system. The options available include *Floppy*, *LS120*, *Hard Disk*, *CDROM*, *ZIP100*, *USB-FDD*, *USB-CDROM* and *Disable*.

**Boot Other Device**

These fields allow the system to search for an operating system from other devices other than the ones selected in the First/Second/Third Boot Device.

**Boot Up NumLock Status**

This allows you to activate the NumLock function after you power up the system.

#### **Gate A20 Option**

This field allows you to select how Gate A20 is worked. Gate A20 is a device used to address memory above 1 MB.

#### **Typematic Rate Setting**

When disabled, continually holding down a key on your keyboard will generate only one instance. When enabled, you can set the two typematic controls listed next. By default, this field is set to **Disabled**.

#### **Typematic Rate (Chars/Sec)**

When the typematic rate is enabled, the system registers repeated keystrokes speeds. Settings are from 6 to 30 characters per second.

#### **Typematic Delay (Msec)**

When the typematic rate is enabled, this item allows you to set the time interval for displaying the first and second characters. By default, this item is set to **250msec**.

#### **Security Option**

This field allows you to limit access to the System and Setup. The default value is **Setup**. When you select **System**, the system prompts for the User Password every time you boot up. When you select **Setup**, the system always boots up and prompts for the Supervisor Password only when the Setup utility is called up.

#### **APIC Mode**

APIC stands for Advanced Programmable Interrupt Controller. The default setting is **Enabled**.

#### **MPS Version Control for OS**

This option specifies the MPS (Multiprocessor Specification) version for your operating system. MPS version 1.4 added extended configuration tables to improve support for multiple PCI bus configurations and improve future expandability. The default setting is **1.4**.

#### **OS Select for DRAM > 64MB**

This option allows the system to access greater than 64MB of DRAM memory when used with OS/2 that depends on certain BIOS calls to access memory. The default setting is **Non-OS/2**.

#### **Console Redirection**

Set the Console Redirection from COM port to UNIX terminal on BIOS boot up.  
Default : Enabled

#### **Baud Rate**

The default value of the Baud Rate is 19200.

#### **Agent Connect Via**

By default, this item is set to NULL.

#### **Agent Wait Time (min)**

By default, the Agent Wait Time is set to 1 minute.

#### **Agent After Boot**

By default, this field is disabled.

#### **Report No FDD For WIN 95**

If you are using Windows 95/98 without a floppy disk drive, select Enabled to release IRQ6. This is required to pass Windows 95/98's SCT test. You should also disable the Onboard FDC Controller in the Integrated Peripherals screen when there's no floppy drive in the system. If you set this feature to Disabled, the BIOS will not report the missing floppy drive to Win95/98.

#### **Small Logo (EPA) Show**

The EPA logo appears at the right side of the monitor screen when the system is boot up. The default setting is **Disabled**.

### **Advanced Chipset Features**

This Setup menu controls the configuration of the chipset.

Phoenix - AwardBIOS CMOS Setup Utility  
Advanced Chipset Features

DRAM Timing Selectable	By SPD	ITEM HELP
CAS Latency Time	Auto	Menu Level
DRAM RAS# to CAS# Delay	Auto	
DRAM RAS# Precharge	Auto	
Precharge Delay	Auto	
SLP_S4# Assertion Width		
System Memory Frequency	Auto	
System BIOS Cacheable	Enabled	
Video BIOS Cacheable	Enabled	
Memory Hole at 15M-16M	Disabled	
PCI Express Root	Press Enter	
On-Chip Video Memory	Press Enter	
On-Chip Frame Buffer Size Memory	8MB	
DVMT Version	DVMT 3.0	
FIXED Memory Size	64MB	
DVMT Memory Size	64MB	
Boot Display	Auto	

**DRAM Timing Selectable**

This option refers to the method by which the DRAM timing is selected. The default is **By SPD**.

**CAS Latency Time**

You can configure CAS latency time in HCLKs as 2 or 2.5 or 3. The system board designer should set the values in this field, depending on the DRAM installed. Do not change the values in this field unless you change specifications of the installed DRAM or the installed CPU.

**DRAM RAS# to CAS# Delay**

This option allows you to insert a delay between the RAS (Row Address Strobe) and CAS (Column Address Strobe) signals. This delay occurs when the SDRAM is written to, read from or refreshed. Reducing the delay improves the performance of the SDRAM.

**DRAM RAS# Precharge**

This option sets the number of cycles required for the RAS to accumulate its charge before the SDRAM refreshes. The default setting for the Active to Precharge Delay is **Auto**.

**Precharge Delay**

The default setting for the Precharge Delay is **Auto**.

**System Memory Frequency**

This field sets the frequency of the DRAM memory installed. The default setting is **Auto**. The other settings are *DDR266*, *DDR333*, *DDR320* and *DDR400*.

**System BIOS Cacheable**

The setting of *Enabled* allows caching of the system BIOS ROM at F000h-FFFFh, resulting in better system performance. However, if any program writes to this memory area, a system error may result.

**Video BIOS Cacheable**

The Setting *Enabled* allows caching of the video BIOS ROM at C0000h-F7FFFh, resulting in better video performance. However, if any program writes to this memory area, a system error may result.

**Memory Hole At 15M-16M**

In order to improve performance, certain space in memory can be reserved for ISA cards. This memory must be

**On-Chip Frame Buffer Size Memory**

Allow user to select the amount of system memory pre-allocated by the internal graphics device.

Integrated Peripherals

On-Chip IDE Device	Press Enter	ITEM HELP
Onboard Device	Press Enter	Menu Level
SuperIO Device	Press Enter	
Onboard LAN Boot	Press Enter	
2nd SuperIO Device	Press Enter	

Phoenix - AwardBIOS CMOS Setup Utility  
OnChip IDE Device

IDE Block Mode	Enabled	ITEM HELP
IDE DMA transfer access	Enabled	Menu Level
On-Chip Primary PCI IDE	Enabled	
IDE Primary Master PIO	Auto	If your IDE hard drive supports block mode select Enabled for automatic detection of the optimal number of block read/writes per sector the drive can support
IDE Primary Slave PIO	Auto	
IDE Primary Master UDMA	Auto	
IDE Primary Slave UDMA	Auto	
On-Chip Secondary PCI IDE	Enabled	
IDE Secondary Master PIO	Auto	
IDE Secondary Slave PIO	Auto	
IDE Secondary Master UDMA	Auto	
IDE Secondary Slave UDMA	Auto	
*** On-Chip Serial ATA Setting ***		
SATA Mode	IDE	
On-Chip Serial ATA	Auto	
Serial ATA Port0 Mode	SATA0 master	
Serial ATA Port1 Mode	SATA1 master	

Phoenix - AwardBIOS CMOS Setup Utility  
Onboard Device

USB Controller	Enabled	ITEM HELP
USB 2.0 Controller	Enable	Menu Level
USB Keyboard Support	Enable	
AC97 Audio	Auto	

Phoenix - AwardBIOS CMOS Setup Utility  
SuperIO Device

Power On Function	BUTTON ONLY	ITEM HELP
KB Power On Password	Enter	Menu Level
Hot Key Power On	Ctrl-F1	
Onboard FDC Controller	Enabled	
Onboard Serial Port 1	3F8/IRQ4	
Onboard Serial Port 2	2F8/IRQ3	
UART Mode Select	Normal	
RxD , TxD Active	Hi, Lo	
IR Transmission Delay	Enabled	
UR2 Duplex Mode	Half	
Use IR Pins	IR-Rx2Tx2	
PWRON After PWR-Fail	On	

**IDE HDD Block Mode**

This field allows your hard disk controller to use the fast block mode to transfer data to and from your hard disk drive.

#### **IDE DMA Transfer Access**

Allows IDE transfer to be done in DMA mode

#### **OnChip Primary/Secondary PCI IDE**

The integrated peripheral controller contains an IDE interface with support for two IDE channels. Select *Enabled* to activate each channel separately.

#### **IDE Primary/Secondary Master/Slave PIO**

These fields allow your system hard disk controller to work faster. Rather than have the BIOS issue a series of commands that transfer to or from the disk drive, PIO (Programmed Input/Output) allows the BIOS to communicate with the controller and CPU directly.

The system supports five modes, numbered from 0 (default) to 4, which primarily differ in timing. When Auto is selected, the BIOS will select the best available mode.

#### **IDE Primary/Secondary Master/Slave UDMA**

These fields allow your system to improve disk I/O throughput to 33Mb/sec with the Ultra DMA/33 feature. The options are *Auto* and *Disabled*.

#### **USB Controller**

The options for this field are *Enabled* and *Disabled*. By default, this field is set to *Enabled*.

#### **USB 2.0 Controller**

The options for this field are *Enabled* and *Disabled*. By default, this field is set to *Enabled*. In order to use USB 2.0, necessary OS drivers must be installed first.

#### **USB Keyboard Support**

The options for this field are *Enabled* and *Disabled*. By default, this field is set to *Enabled*.

#### **AC97 Audio**

The default setting of the AC97 Audio is *Auto*.

#### **Onboard FDC Controller**

Select *Enabled* if your system has a floppy disk controller (FDC) installed on the motherboard and you wish to use it. If you install an add-in FDC or the system has no floppy drive, select *Disabled* in this field. This option allows you to select the onboard FDD port.

#### **UART Mode Select**

This field determines the UART 2 mode in your computer. The default value is *Normal*. Other options include *IrDA* and *ASKIR*.

#### **Onboard LAN Boot**

Enable or Disable the Marvell 88E8053 PXE Boot ROM.

## **Power Management Setup**

The Power Management Setup allows you to save energy of your system effectively.

Phoenix - AwardBIOS CMOS Setup Utility  
Power Management Setup

ACPI Function	Enabled	ITEM HELP
Power Management	User Define	Menu Level
Video Off Method	V/H SYNC+Blank	
Video Off In Suspend	Yes	
Suspend Type	Stop Grant	
Modem Use IRQ	3	
Suspend Mode	Disabled	
HDD Power Down	Disabled	
Soft-Off by PWR-BTTN	Instant-Off	
CPU THRM-Throttling	50%	
Wake-Up by PCI Card	Disabled	
Power On by Ring	Disabled	
Wake Up on Lan	Disabled	
Resume by Alarm	Disabled	
Date (of Month) Alarm	0	
Time (hh:mm:ss) Alarm	0 : 0 : 0	
** Reload Global Timer Events **		
Primary IDE 0	Enabled	
Primary IDE 1	Enabled	
Secondary IDE 0	Enabled	
Secondary IDE 1	Enabled	
FDD, COM, LPT Port	Enabled	
PCI PIRQ[A-D] #	Enabled	

**ACPI Function**

Enable this function to support ACPI (Advance Configuration and Power Interface).

**Power Management**

This field allows you to select the type of power saving management modes. There are four selections for Power Management.

- Min. Power Saving      Minimum power management
- Max. Power Saving     Maximum power management.
- User Define            Each of the ranges is from 1 min. to 1hr. Except for HDD Power Down which ranges from 1 min. to 15 min.

**Video Off Method**

This field defines the Video Off features. There are three options.

- V/H SYNC + Blank    Default setting, blank the screen and turn off vertical and horizontal scanning.
- DPMS                  Allows BIOS to control the video display.
- Blank Screen         Writes blanks to the video buffer.

**Video Off In Suspend**

When enabled, the video is off in suspend mode. The default setting is **Yes**.

**Suspend Type**

The default setting for the Suspend Type field is **Stop Grant**.

**Modem Use IRQ**

This field sets the IRQ used by the Modem. By default, the setting is **3**.

**Suspend Mode**

When enabled, and after the set time of system inactivity, all devices except the CPU will be shut off.

**HDD Power Down**

When enabled, and after the set time of system inactivity, the hard disk drive will be powered down while all other devices remain active.

**Soft-Off by PWRBTN**

This field defines the power-off mode when using an ATX power supply. The *Instant Off* mode allows powering off immediately upon pressing the power button. In the *Delay 4 Sec* mode, the system powers off when the power button is pressed for more than four seconds or enters the suspend mode when pressed for less than 4 seconds.

**CPU THRM-Throttling**

When the system enters Doze mode, the CPU clock runs only part of the time. You may select the percent of time that the clock runs.

**Wake-Up by PCI Cards**

Enable this field to allow wake up function through a PCI card.

**Power On by Ring**

This field enables or disables the power on of the system through the modem connected to the serial port or LAN.

**Wake Up On LAN**

Enable this field to allow wake up function through the onboard LAN.

**Resume by Alarm**

This field enables or disables the resumption of the system operation. When enabled, the user is allowed to set the *Date* and *Time*.

**Reload Global Timer Events**

The HDD, FDD, COM, LPT Ports, and PCI PIRQ are I/O events that can prevent the system from entering a power saving mode or can awaken the system from such a mode. When an I/O device wants to gain the attention of the operating system, it signals this by causing an IRQ to occur. When the operating system is ready to respond to the request, it interrupts itself and performs the service.

**PNP/PCI Configurations**

This option configures the PCI bus system. All PCI bus systems on the system use INT#, thus all installed PCI cards must be set to this value.

Phoenix - AwardBIOS CMOS Setup Utility  
PnP/PCI Configurations

PNP OS Install	No	ITEM HELP
Reset Configuration Data	Disabled	Menu Level
Resources Controlled By	Auto (ESCD)	Default is Disabled.
IRQ Resources	Press Enter	Select Enabled to reset
DMA Resources	Press Enter	Extended System
PCI/VGA Palette Snoop	Disabled	Configuration Data
INT Pin 1 Assignment	Auto	(ESCD) when you exit
INT Pin 2 Assignment	Auto	Setup if you have
INT Pin 3 Assignment	Auto	installed a new add-on
INT Pin 4 Assignment	Auto	and the system
INT Pin 5 Assignment	Auto	reconfiguration has
INT Pin 6 Assignment	Auto	caused such a serious
INT Pin 7 Assignment	Auto	conflict that the OS
INT Pin 8 Assignment	Auto	cannot boot

**PNP OS Install**

Enable the PNP OS Install option if it is supported by the operating system installed. The default value is **No**.

**Reset Configuration Data**

This field allows you to determine whether to reset the configuration data or not. The default value is **Disabled**.

**Resources Controlled by**

This PnP BIOS can configure all of the boot and compatible devices automatically with the use of a use a PnP operating system such as Windows 95.

**PCI/VGA Palette Snoop**

Some non-standard VGA display cards may not show colors properly. This field allows you to set whether or not MPEG ISA/VESA VGA cards can work with PCI/VGA. When this field is enabled, a PCI/VGA can work with an MPEG ISA/VESA VGA card. When this field is disabled, a PCI/VGA cannot work with an MPEG ISA/VESA card.

**PC Health Status**

This section shows the parameters in determining the PC Health Status. These parameters include temperatures, fan speeds and voltages.

Phoenix - AwardBIOS CMOS Setup Utility  
PC Health Status

CPU Warning Temperature	Disabled	ITEM HELP
Current System Temp.		Menu Level
Current CPU1 Temp		
Vcore (V)		
+3.3V		
+5V		
+12V		
-12V		
VBAT		
5VSB(V)		
Shutdown Temperature	Disabled	
Current CPUFAN1 Speed		
Current CPUFAN2 Speed		
Current CPUFAN3 Speed		
Current CPUSYS1 Speed		
1st Smart Fan II Temperature		
Level2 Temperature		
2nd Smart Fan II Temperature		
Level2 Temperature		

**CPU Warning Temperature**

This field allows the user to set the temperature so that when the temperature is reached, the system sounds a warning. This function can help prevent damage to the system that is caused by overheating.

**Temperatures/Fan Speeds/Voltages**

These fields are the parameters of the hardware monitoring function feature of the motherboard. The values are read-only values as monitored by the system and show the PC health status.

**Shutdown Temperature**

This field allows the user to set the temperature by which the system automatically shuts down once the threshold temperature is reached. This function can help prevent damage to the system that is caused by overheating.

**1st Smart Fan II Temperature (SYS\_FAN1 connector)**

Enable or Disable the first phase Smart FAN functionality of SYS\_FAN1 connector.

Configuration option: [30°C] [35°C] [40°C] [45°C] [50°C] [55°C] [60°C]

If the value is set, the fan turns to 25% duty cycle when the temperature of CPU reach to the value.

The default value is **Disable**.

**2nd Smart Fan II Temperature** (CPU\_FAN1 / CPU\_FAN2 / CPU\_FAN3 connectors)

Enable or Disable the first phase Smart FAN functionality of CPU\_FAN1/CPU\_FAN2/CPU\_FAN3 connectors.

Configuration option: [30°C] [35°C] [40°C] [45°C] [50°C] [55°C] [60°C]

If the value is set, the fan turns to 25% duty cycle when CPU has reached temperature of approximately value.

The default value is [30°C].

#### **Level2 Temperature**

Set the second phase Smart FAN functionality.

Configuration option: [5°C] [10°C] [15°C]

If both the value and the **Smart Fan II Temperature** are set, the fan turns to 50% duty cycle when CPU has reached temperature of approximately (first phase + second phase temperature).

#### **The third phase Smart FAN functionality:**

If the CPU is over temperature of approximately (first phase + second phase temperature + 10°C), the fan turns to 75% duty cycle.

#### **The final phase Smart FAN functionality:**

If the CPU is over temperature of approximately (first phase + second phase temperature + 20°C), the fan turns to 100% duty cycle.

This section shows the user how to configure the processor frequency.

Phoenix - AwardBIOS CMOS Setup Utility  
Frequency/Voltage Control

CPU Clock Ratio		ITEM HELP
Auto Detect DIMM/PCI Clk	Enable	
Spread Spectrum	Disabled	Menu Level

**Auto Detect DIMM/PCI Clk**

This field enables or disables the auto detection of the PCI clock.

**Spread Spectrum**

This field sets the value of the spread spectrum. The default setting is **Disabled**. This field is for CE testing use only.

**Load Fail-Safe Defaults**

This option allows you to load the troubleshooting default values permanently stored in the BIOS ROM. These default settings are non-optimal and disable all high-performance features.

**Load Setup Defaults**

This option allows you to load the default values to your system configuration. These default settings are optimal and enable all high performance features.

**Set Supervisor/User Password**

These two options set the system password. Supervisor Password sets a password that will be used to protect the system and Setup utility. User Password sets a password that will be used exclusively on the system. To specify a password, highlight the type you want and press <Enter>. The Enter Password: message prompts on the screen. Type the password, up to eight characters in length, and press <Enter>. The system confirms your password by asking you to type it again. After setting a password, the screen automatically returns to the main screen.

To disable a password, just press the <Enter> key when you are prompted to enter the password. A message will confirm the password to be disabled. Once the password is disabled, the system will boot and you can enter Setup freely.

**Save & Exit Setup**

This option allows you to determine whether or not to accept the modifications. If you type "Y", you will quit the setup utility and save all changes into the CMOS memory. If you type "N", you will return to Setup utility.

**Exit Without Saving**

Select this option to exit the Setup utility without saving the changes you have made in this session. Typing "Y" will quit the Setup utility without saving the modifications. Typing "N" will return you to Setup utility.

If jumpers are removed from JP4 leaving 1-2 & 3-4 to open status, ETH0 & ETH1 will be under Bypass mode (Bypass LED off).

User could initiate it to the Normal mode (Bypass LED light up) then re-trigger it in a loop.

Once the system hangs, ETH0 & ETH1 will switch to Bypass mode after timeout.

The following is the example code for the Bypass function.

```
#include <stdio.h>
#include <stdlib.h>
#include <string.h>
#include <unistd.h>
#include <errno.h>
#include <fcntl.h>
#include <sys/time.h>
#include <sys/types.h>
#include <sys/stat.h>

#include <asm/io.h> /* linux-specific */

#ifdef __GLIBC__
# include <sys/perm.h>
#endif

void by_pass_init (void) {

    unsigned int i=0;

    outb(0x87,0x4e); //Enter extended function mode
    outb(0x87,0x4e);

    outb(0x2b,0x4e);
    i = inb(0x4f);
    i &= 0xef; //Configure bit 4 as 0 to be watchdog function.
    outb(0x2b,0x4e);
    outb(i,0x4f);

    outb(0x7,0x4e);
    outb(0x8,0x4f); //watchdog in logic device 8

    outb(0x30,0x4e); //Active wdt
    outb(0x1,0x4f);

    outb(0xf5,0x4e);
    i = inb(0x4f);
    i &= 0xf7;
    outb(0xf5,0x4e);
    outb(i,0x4f);

    outb(0xf6,0x4e);
    outb(1,0x4f); //Set timeout value to initial the normal mode.

    outb(0xf7,0x4e);
    outb(0x0,0x4f);

    outb(0xaa,0x4e); // Exit extended mode
```

```

    sleep(1);
}

#define TIMEOUT      10

void enable_wdt (void) {

    unsigned int i=0;

    outb(0x87,0x4e);//Enter extended function mode
    outb(0x87,0x4e);

    outb(0x2b,0x4e);
    i = inb(0x4f);
    i &= 0xef;//Configure bit 4 as 0 to be watchdog function.
    outb(0x2b,0x4e);
    outb(i,0x4f);

    outb(0x7,0x4e);
    outb(0x8,0x4f);//watchdog in logic device 8

    outb(0x30,0x4e);//Active wdt
    outb(0x1,0x4f);

    outb(0xf5,0x4e);
    i = inb(0x4f);

    /*Select watchdog count mode */
    //i = i | 0x8; //Select minute
    i = i & 0xf7; //Select second
    outb(0xf5,0x4e);
    outb(i,0x4f);

    outb(0xf6,0x4e);
    outb(TIMEOUT,0x4f);

    outb(0xf7,0x4e);
    outb(0x0,0x4f);

}

void retrigger ( void ) {

    outb(0xf6,0x4e);
    outb(TIMEOUT,0x4f);
}

/* Disable WDT function */
void dis_wdt ( void ) {

    outb(0xf6,0x4e);
    outb(0x00,0x4f);
}

int main(int argc, char **argv)
{

    int c;

    setuid(0); /* if we're setuid, force it on */

```

```

if ( iopl(3) ) {
    fprintf(stderr, "iopl(): %s\n", strerror(errno));
    return -1;
}

by_pass_init();

/* Enable watchdog function and retrigger TIMEOUT countdown */
enable_wdt();

for(;;) {
    sleep(1);/* Function check.
             if timeout, switch to By Pass mode.
             Or , call retrigger() for retrigger WDT. */

    /* Display countdown */
    outb(0xf6,0x4e);
    c = inb(0x4f);
    printf("Watchdog countdown %d\n",c);

    if ( ! c ) {
        printf("Switch to Bypass mode !\n");
        break;
    }
    //retrigger();//retrigger watchdog
}

//dis_wdt();//Disable watchdog function

return 0;
}

```

We offer a Factory Default Setting function for more flexibility.

The programmer could design a function such as loading the software default setting. It will restore the software default setting after the user presses the Factory Default button.

The following is the example code for the Factory Default Setting function.

```
#include <stdio.h>
#include <stdlib.h>
#include <string.h>
#include <unistd.h>
#include <errno.h>
#include <fcntl.h>
#include <sys/time.h>
#include <sys/types.h>
#include <sys/stat.h>

#include <asm/io.h> /* linux-specific */

#ifdef __GLIBC__
# include <sys/perm.h>
#endif

int fd_polling ( void ) {

    unsigned int i=0;

    //Enter Extended Function Mode
    outb(0x87,0x4e);
    outb(0x87,0x4e);

    //Select logic device 7
    outb(0x7,0x4e);
    outb(0x7,0x4f);

    //Assign GPIO1 (GP15)
    outb(0x2a,0x4e);
    i = inb(0x4f);
    i |= 0x82;
    outb(0x2a,0x4e);
    outb(i,0x4f);

    //Active logic device 7
    outb(0x30,0x4e);
    outb(0x1,0x4f);

    //Select I/O mode
    //Configure GP15 as an input port.
    outb(0xf0,0x4e);
    i = inb(0x4f);
    i &= 0xff;
    i |= 0x20;
    outb(i,0x4f);

    //Select inversion mode
    outb(0xf2,0x4e);
    i = inb(0x4f);
```

```

i &= 0xdf;
outb(i,0x4f);

/* Value of Inversion Register :
Only high nibble is available for this function.
When set to a 1, the incoming/outgoing port value is inverted.
When set to a 0, the incoming/outgoing port value is the same as in Data Register.

Value of I/O Selection Register :
Only high nibble is available for this function.
When set to a 1, respective GPIO port is programmed as an input port.
When set to a 0, respective GPIO port is programmed as an output port.

Value of Output Data / Input Data :
Only high nibble is available for this function.
If a port is assigned to be an output port, then its respective bit can be read/written.

If a port is assigned to be an input port, then its respective bit can be read only.
*/

outb(0xf1,0x4e);
i = inb(0x4f);
i >>= 5;

return i;

}

int main( int argc , char **argv )
{
int status,i=0;

setuid(0); /* if we're setuid, force it on */

if ( iopl(3) ) {
printf(stderr, "iopl(): %s\n", strerror(errno));
return -1;
}

for(;;) {

usleep(10000);
status = fd_polling();

if ( status == 0 ) { // Check the Factory Default button
i++;
printf("### MB893 Load Default Setting (%d) ###\n",i);
usleep(500000);
//You could call your function here to load the
//software default value.
}
}

return 0;
}

```

The following is an example code for the GPO LED function.

```
#include <stdio.h>
#include <stdlib.h>
#include <string.h>
#include <unistd.h>
#include <errno.h>
#include <fcntl.h>
#include <sys/time.h>
#include <sys/types.h>
#include <sys/stat.h>

#include <asm/io.h> /* linux-specific */

#ifdef __GLIBC__
# include <sys/perm.h>
#endif

void gpo_onoff ( unsigned int pos , int flag ) {

    unsigned int led,i=0;

    //Enter Extended Function Mode
    outb(0x87,0x4e);
    outb(0x87,0x4e);

    //Select logic device 7
    outb(0x7,0x4e);
    outb(0x7,0x4f);

    //Assign pin 121-128 bit(7...2) to be 1
    outb(0x2f,0x4e);
    i = inb(0x4f);
    i |= 0xfc;
    outb(0x2f,0x4e);
    outb(i,0x4f);

    //Active logic device 7
    outb(0x30,0x4e);
    outb(0x1,0x4f);

    //Select I/O mode
    outb(0xf0,0x4e);
    i = inb(0x4f);
    i &= 0x3;
    outb(0xf0,0x4e);
    outb(i,0x4f);

    //Select inversion mode
    outb(0xf2,0x4e);
    i = inb(0x4f);
    i &= 0x3;
    outb(0xf2,0x4e);
    outb(i,0x4f);
```

/\* Value of Inversion Register :  
Only high nibble is available for this function.  
When set to a 1, the incoming/outgoing port value is inverted.  
When set to a 0, the incoming/outgoing port value is the same as in Data Register.

Value of I/O Selection Register :  
Only high nibble is available for this function.  
When set to a 1, respective GPIO port is programmed as an input port.  
When set to a 0, respective GPIO port is programmed as an output port.

Value of Output Data / Input Data :  
Only high nibble is available for this function.  
If a port is assigned to be an output port, then its respective bit can be read/written.

If a port is assigned to be an input port, then its respective bit can be read only.

\*/

```
switch (pos) {  
  
    case 1:  
        outb(0xf1,0x4e);//GP10 , LED1  
        led = inb(0x4f);  
        led &= 0xff;  
        led = ( flag==1 ?(led | 1) :(led & 0xfe));  
        outb(0xf1,0x4e);  
        outb(led,0x4f);  
        break;  
  
    case 2:  
        outb(0xf1,0x4e);//GP11 , LED2  
        led = inb(0x4f);  
        led &= 0xff;  
        led = ( flag==1 ?(led | 2) :(led & 0xfd));  
        outb(0xf1,0x4e);  
        outb(led,0x4f);  
        break;  
  
    case 3:  
        outb(0xf1,0x4e);//GP12 , LED3  
        led = inb(0x4f);  
        led &= 0xff;  
        led = ( flag==1 ?(led | 4) :(led & 0xfb));  
        outb(0xf1,0x4e);  
        outb(led,0x4f);  
        break;  
  
    case 4:  
        outb(0xf1,0x4e);//GP13 , LED4  
        led = inb(0x4f);  
        led &= 0xff;  
        led = ( flag==1 ?(led | 8) :(led & 0xf7));  
        outb(0xf1,0x4e);  
        outb(led,0x4f);  
        break;  
  
    case 5:  
        outb(0xf1,0x4e);//GP14 , LED5  
        led = inb(0x4f);  
        led &= 0xff;  
        led = ( flag==1 ?(led | 0x10) :(led & 0xef));  
        outb(0xf1,0x4e);  
        outb(led,0x4f);  
        break;  
  
}
```

```

    }

    outb(0xaa,0x4e); // Exit extended function mode
}

#define ON 1
#define OFF 0

int main( int argc , char **argv )
{
    setuid(0); /* if we're setuid, force it on */

    if ( iopl(3) ) {
        fprintf(stderr, "iopl(): %s\n", strerror(errno));
        return -1;
    }

    for (;;) {
        gpo_onoff(1,ON);
        usleep(200000);
        gpo_onoff(1,OFF);
        usleep(200000);

        gpo_onoff(2,ON);
        usleep(200000);
        gpo_onoff(2,OFF);
        usleep(200000);

        gpo_onoff(3,ON);
        usleep(200000);
        gpo_onoff(3,OFF);
        usleep(200000);

        gpo_onoff(4,ON);
        usleep(200000);
        gpo_onoff(4,OFF);
        usleep(200000);

        gpo_onoff(5,ON);
        usleep(200000);
        gpo_onoff(5,OFF);
        usleep(200000);
    }

    return 0;
}

```

## Chapter 15 System Architecture

The following block diagram illustrates a basic design reference of MB935, a highly integrated system solution.

