

# ECX810

Intel® EP80579

ECX Embedded Board

# USER'S MANUAL

Version 1.0

---

## Acknowledgments

Award is a registered trademark of Award Software International, Inc.

PS/2 is a trademark of International Business Machines Corporation.

Intel and Intel EP80579 Integrated Processor are registered trademarks of Intel Corporation.

Microsoft Windows is a registered trademark of Microsoft Corporation.

Winbond is a registered trademark of Winbond Electronics Corporation.

All other product names or trademarks are properties of their respective owners.

---

# Table of Contents

<b>Introduction .....</b>	<b>1</b>
Product Description.....	1
Checklist.....	2
ECX810 Specifications .....	3
Board Dimensions .....	4
<b>Installations .....</b>	<b>5</b>
Installing the Memory .....	6
Setting the Jumpers .....	7
Connectors on ECX810.....	10
<b>BIOS Setup.....</b>	<b>21</b>
<b>Drivers Installation .....</b>	<b>41</b>
<b>Appendix .....</b>	<b>43</b>
A. Watchdog Timer Configuration .....	43

---

This page is intentionally left blank.

# Introduction

## Product Description

---

The ECX810 ECX (Embedded Compact Extended) board incorporates the Intel® EP80579 Integrated Processor for Embedded Computing. The EP80579 System on a Chip (SoC) is a new generation processor that is cost optimized for a wide range of applications. EP80579 delivers the balance of a powerful IA-32 processor core, standards-based chipset, and acceleration /communications-focused I/O capabilities.

The EP80579 SoC integrates features into a single device with memory controller hubs (IMCH) and I/O controller hubs (IICH). The IMCH has built-in memory controllers for external memory and the IICH has standard IA I/O peripheral capabilities.

The ECX810's EP80579 IA-32 core is a derivative of the Intel® Pentium® M processor. This low power IA-32 core is based on 90-nm process technology featuring 256-Kbyte L2 cache and 400/533 MHz quad-pumped internal front-side bus (FSB). With a DDR2 SO-DIMM socket on board, the board supports up to 2GB of DDR2 system memory.

It integrates three Gigabit Ethernet MAC interfaces. The MAC fully implements the IEEE 802.3z, Carrier Sense Multiple Access with Collision Detection (CSMA/CD) method and physical layer specifications. The GbE features include RGMII/RMII interface to PHY devices. Multi-speed operation 10/100/1000 Mbps.

The main features of the ECX810 board are:

- Supports Intel EP80579 processors in 600/1066/1200MHz
- EP80579 built-in USB 2.0 host controller supports 2 ports  
One port for USB and another for Audio use
- EP80579 built-in SATA controller supports 2 ports:  
One port for SATA connector and another port for Compact Flash thru (Acard) serial ATA Bridge Chip ARC772  
One DDR2 SDRAM SO-DIMM, Max. 2GB memory
- Integrated Three Gigabit Ethernet MACs + PHY
- 1x SATA, 1x USB 2.0, 4x COM, Watchdog timer,
- Interface connector for XGI Daughter board (ID810).
- Dimensions of the board are 105mm x 146mm.

## **Checklist**

---

---

Your ECX810 package should include the items listed below.

- The ECX810 ECX embedded board
- This User's Manual
- 1 CD containing chipset drivers and flash memory utility

## ECX810 Specifications

<b>Form Factor</b>	ECX
<b>CPU Type</b>	Intel Architecture (IA-32) processor
<b>CPU Voltage</b>	1.0V ~ 1.3V
<b>CPU Speed</b>	600,1066,1200MHz
<b>CPU Operate Frequency</b>	400MHz/533MHz FSB
<b>Cache</b>	256KB
<b>Green /APM</b>	APM1.2
<b>CPU &amp; Chipset</b>	Intel EP80579 System on a Chip (SoC) Integrated Intel® Architecture (IA) processor and chipset (MCH/ICH) technology 1088-Ball FCBGA package
<b>BIOS</b>	Award BIOS, support ACPI Function
<b>Memory</b>	DDR2 400/533/667/800 SO-DIMM x1 (w/o ECC function), Max. 2GB, (600Mhz CPU at DDR2 667MHz only )
<b>VGA &amp; LVDS Panel</b>	XGI /Z11 2D Accelerator 1600 x 1200 PCI-E X 1 bus; Graphic memory DDRII, 32M Supports CRT (via IB810 daughter board) Supports 18-bit single channel LVDS (via IB810L daughter board)
<b>LAN</b>	The integrated Three Gigabit Ethernet MACs+ Marvell 88E81145 Gigabit LAN transceiver with 3 x RJ45 Connector on the board edge
<b>USB (Universal Serial Bus)</b>	EP80579 built-in USB 2.0 host controller Support 1 port. (Another port occupied for Audio use)
<b>Serial ATA Ports</b>	EP80579 built-in SATA controller, supports 2 ports: One port for SATA Connector, 300MB/s Another port for CFD thru (Acard) serial ATA Bridge Chip ARC772(optional)
<b>Compact Flash</b>	Acard serial ATA Bridge Chip ARC772 for CF connector
<b>USB Audio</b>	USB Audio Codec PCM2902 for Line-out, Line-in
<b>LPC I/O</b>	W83627EHG: COM1, COM2 (RS232), & Hardware monitor (3 thermal inputs, 4 voltage monitor inputs, 1 fan Header)
<b>Digital IO</b>	4 in & 4 out
<b>Keyboard/Mouse</b>	Supports PS/2 Keyboard/Mouse connector
<b>Expansion Region</b>	Interface connector for XGI VGA Daughter board (ID810)
<b>Edge Connector</b>	PS/2 Connector for keyboard/mouse Gigabit LAN RJ-45 x3 Single USB stack connector DB9 for COM 1
<b>On Board Header/Connector</b>	2x15 box-header for COM2.3.4 CF Connector @ solder side(optional) 10-pin header for Digital I/O SATA connector for SATA port 2x15 header for DB15 VGA Connector (via ID810) Connector for VGA & DF13-Connector for LVDS (via ID810L) 2x8 header for Front & audio Line-out & Line-in (via ID820) 2x8 header for VPN Front LED (via ID830)
<b>Watchdog Timer</b>	Yes (256 segments, 0, 1, 2...255 sec/min)
<b>System Voltage</b>	+5V, +3.3V, +12V, 5VSB
<b>Other</b>	Modem Wakeup.
<b>Daughter Board (optional)</b>	ID810 - CRT only ID810L- DF-13 connector ID820 - Front Connector & Audio Line-in & Line- out ID830 - VPN RJ45 LED
<b>Board Size</b>	105mm x 146mm

# Board Dimensions

Below are dimensions of the board (top and bottom view.)

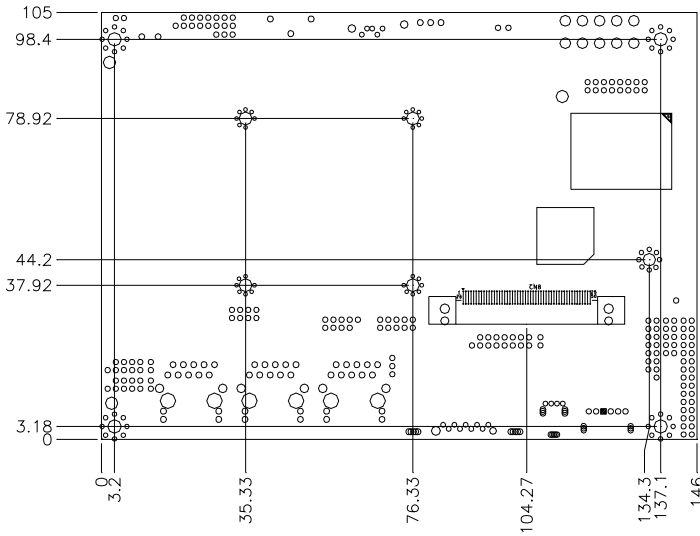
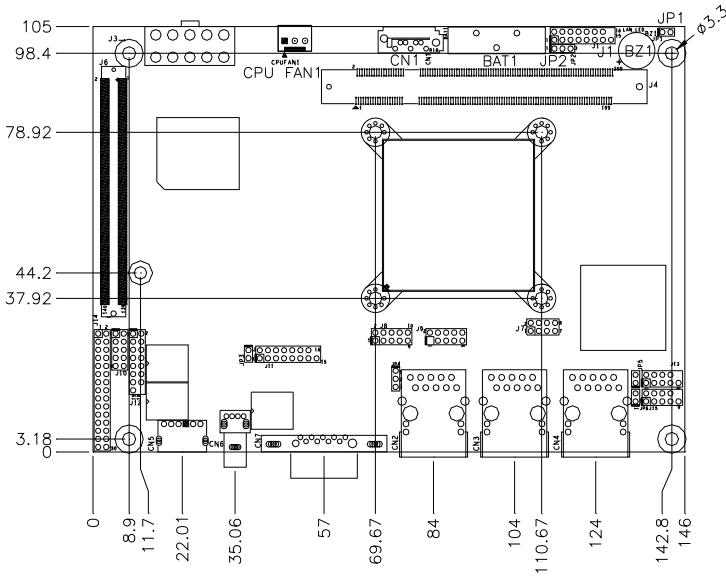

## Installations

This section provides information on how to use the jumpers and connectors on the ECX810 in order to set up a workable system. The topics covered are:

Installing the Memory .....	6
Setting the Jumpers.....	7
Connectors on ECX810.....	10

## Installing the Memory

---

The ECX810 supports one DDR2 SO-DIMM memory socket for a maximum total memory of 2GB, DDR2 400/533/667/800 (w/o ECC function).

Note: A 600MHz onboard processor will support DDR2 400/533/667MHz while 1200MHz & 1066MHz processors will support DDR2 400/533/667/800 MHz.

### Installing and Removing Memory Modules

To install DDR2 modules, locate the memory socket on the board and perform the following steps:

1. Hold the DDR2 module so that the keys of the DDR2 module align with those on the memory slot. Remember to unlock first the clips on both sides to give way to the memory module.
2. Gently push the DDR2 module in an angle (vertically) as shown in the picture below until the module reaches the bottom; then lock the module on both sides of the socket.
3. To remove the module, push the clips outward with both hands.

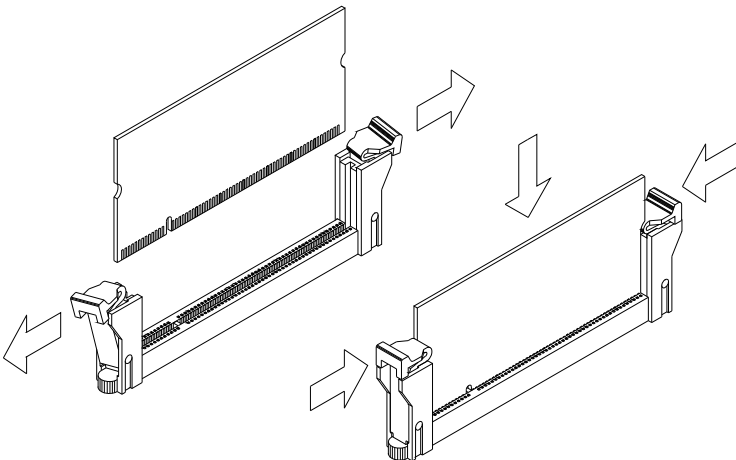

---

## Setting the Jumpers



---

Jumpers are used on ECX810 to select various settings and features according to your needs and applications. Contact your supplier if you have doubts about the best configuration for your needs. The following lists the connectors on ECX810 and their respective functions.

Jumper Locations on ECX810.....	8
JP2: AT (Emulation)/ATX Power Selection .....	9
JP4: Clear CMOS Setting .....	9
JP5, JP6: CAN Bus Termination Setting (Reserved) .....	9





**JP2: AT (Emulation)/ATX Power Selection**



JP2	Power Select
 1 2 3	AT (Emulation)
 1 2 3	ATX

*Note: AT (Emulation) does not require pressing the power button to turn on the system; plugging the AC power will turn on the system.*

**JP4: Clear CMOS Setting**

JP4	Setting
 1 2 3	Normal
 1 2 3	Clear CMOS

**JP5, JP6: CAN Bus Termination Setting (Reserved)**

JP5, JP6	Setting
 Short	Terminate Bus
 Open	No Terminate Bus

## Connectors on ECX810

---

---

The connectors on ECX810 allows you to connect external devices such as keyboard, floppy disk drives, hard disk drives, printers, etc. The following table lists the connectors on ECX810 and their respective functions.

Connector Locations on ECX810.....	11
CN1: Serial ATA Connector.....	12
CN2, CN3, CN4: Gigabit LAN RJ-45.....	12
CN5: PS/2 Keyboard and PS/2 Mouse Connectors .....	12
CN6: USB1 Port Connector.....	12
CN7: COM1 Connector .....	12
CN8: Compact Flash Connector (optional) .....	12
CPUFAN1: System Fan Power Connector .....	12
J1: LAN LED Pin Header .....	13
J3: Power Supply Connector.....	13
J4: SO-DIMM Socket .....	14
J6: VGA Daughter Board Interface Connector.....	14
J7: IEEE1588 Pin Header (Reserved).....	16
J8: GPIO Pin Header (Reserved) .....	17
J9: SPI Pin Header (Debug Only).....	17
J10: Digital I/O Pin Header .....	17
J11: Front Pin Header .....	17
J12: VGA Pin Header .....	18
J13: CAN Bus Port1 Pin Header (Reserved).....	18
J14: COM2/3/4 is a 30-pin Header .....	19
J15: CAN Bus Port2 Pin Header (Reserved).....	19
J16: LPC 80 Port Pin Header (Debug Use Only) .....	20

## Connector Locations on ECX810

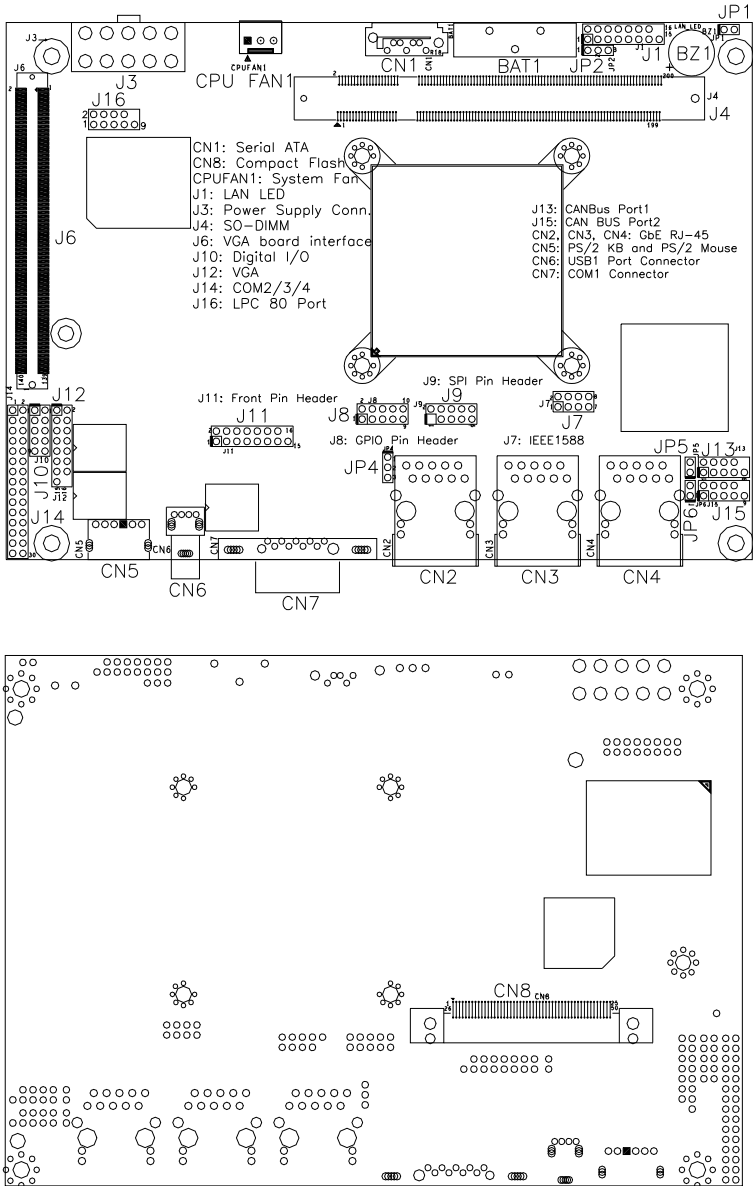

**CN1: Serial ATA Connector**

**CN2, CN3, CN4: Gigabit LAN RJ-45**

**CN5: PS/2 Keyboard and PS/2 Mouse Connectors**

CN5 uses a Y-cable with dual D-connectors for a PS/2 keyboard and a PS/2 mouse.

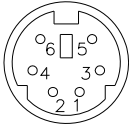

Pin #	Signal Name
1	Mouse data
2	Keyboard data
3	Ground
4	Vcc
5	Mouse Clock
6	Keyboard Clock

**CN6: USB1 Port Connector**

**CN7: COM1 Connector**

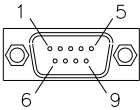

Signal Name	Pin #	Pin #	Signal Name
DCD	1	6	DSR
RXD	2	7	RTS
TXD	3	8	CTS
DTR	4	9	RI
GND	5	10	Not Used

**CN8: Compact Flash Connector (optional)**

**CPUFAN1: System Fan Power Connector**

CPUFAN1 is a 3-pin header for system fans. The fan must be a 12V (500mA).



Pin #	Signal Name
1	Ground
2	+12V
3	Rotation detection

### J1: LAN LED Pin Header

This is for the optional ID830 Front VPN LED module (shown below) is suitable for use in VPN appliance. J1 is connected to ID830 with the EXT109 (150mm) cable.

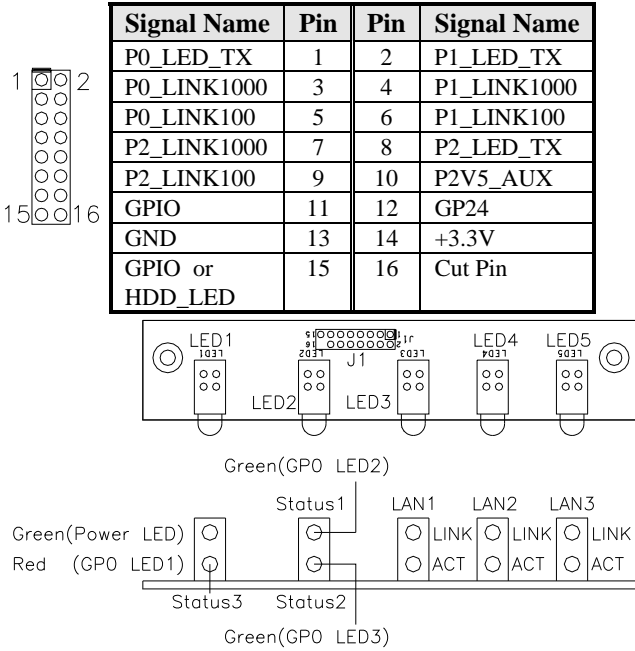

### J3: Power Supply Connector

Use power cable (PW71) to connect to ATX Power Supply.

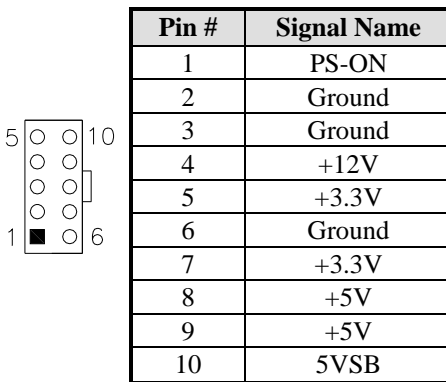

### J4: SO-DIMM Socket

The ECX810 supports one DDR2 SO-DIMM socket for a maximum memory of 2GB, DDR2 400/533/667/800 (w/o ECC function).

Note: A 600MHz onboard processor will support DDR2 400/533/667MHz while 1200MHz & 1066MHz processors will support DDR2 400/533/667/800MHz.

### J6: VGA Daughter Board Interface Connector

J6 is designed for the ID810 (shown and described below) XGI VGA daughter board that supports CRT and 18-bit LVDS displays. However, the CRT VGA cable is to be connected to the J12 pin header on the board.

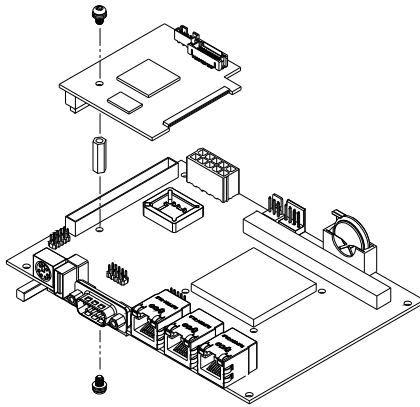

### ID810 XGI VGA daughter board

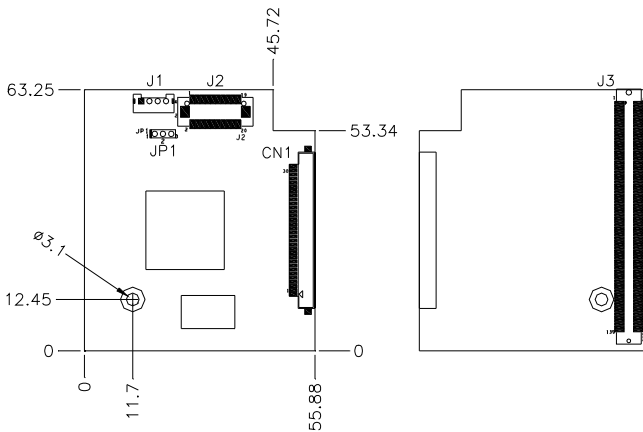

ID810 supports CRT only; it does not support LVDS ID810L, for 18bit LVDS transmitters, supports TFT LCD panel with 800x480 resolution. This resolution is manufacturer's default. For other resolutions, please contact your sales dealer for assistance.

#### J1: Backlight Control Connectors



Pin #	Signal Name
1	+12V
2	Backlight Enable
3	Backlight VRB
4	Ground

#### J2: Support 18 bits single channel LVDS Connectors

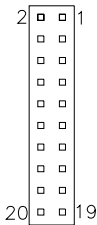

Signal Name	Pin #	Pin #	Signal Name
TX0-	2	1	TX0+
Ground	4	3	Ground
TX1-	6	5	TX1+
5V/3.3V	8	7	Ground
N.C	10	9	N.C
TX2-	12	11	TX2+
Ground	14	13	Ground
TXCLK-	16	15	TXCLK+
5V/3.3V	18	17	ENABKL
+12V	20	19	+12V

\*Depends on JP1 setting (1-2 for 3.3V/default, 2-3 for 5V).

Remarks: J2 supports TFT LCD panel model such as Hitachi TX18D11VM with 18 bit LVDS, resolution of 800x480 pixel

#### JP1: LVDS VDD Select (5V / 3.3V)

JP1	VDD Setting
 1 2 3	3.3V
 1 2 3	5V

CN1: LED Backlight TFT LCD Connectors (Optional)  
 CN1 supports LED Backlight TFT LCD panel such as in CPT model SCLAA070LC0ECW with 18 bit LVDS, resolution of 800x480 pixel

Signal Name	Pin #
+3.3V	1
+3.3V	2
+3.3V	3
N.C.	4
Backlight VRB	5
N.C.	6
Ground	7
TX0-	8
TX0+	9
Ground	10
TX1-	11
TX1+	12
Ground	13
TX2-	14
TX2+	15
Ground	16
TXCLK-	17
TXCLK+	18
Ground	19
N.C.	20
N.C.	21
Ground	22
N.C.	23
+5V	24
+5V	25
+5V	26
N.C.	27
Ground	28
N.C.	29
N.C.	30

**J7: IEEE1588 Pin Header (Reserved)**

	Signal Name	Pin	Pin	Signal Name
1	TSTMDA	1	2	TS_PPS
2	ASMSIG	3	4	AMMSIG
3	RX_SNP	5	6	TX_SNP
4	GND	7	8	GND

**J8: GPIO Pin Header (Reserved)****J9: SPI Pin Header (Debug Only)****J10: Digital I/O Pin Header**

Signal Name	Pin	Pin	Signal Name
GND	1	2	VCC
OUT3	3	4	OUT1
OUT2	5	6	OUT0
IN3	7	8	IN1
IN2	9	10	IN0

**J11: Front Pin Header**

The optional ID820 daughter board supports Front Audio, Power Switch and Reset functions and can be connected to this J11 connector. J11 is connected to ID820 with the EXT109A (120mm) cable.

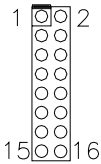

Signal Name	Pin	Pin	Signal Name
F_OUT_R	1	2	F_OUT_L
GND	3	4	GND
L-IN-R	5	6	L-IN-L
PW_SW	7	8	GND
+3.3V	9	10	N.C
RST_SW	11	12	GND
HDD_LED+	13	14	HDD_LED-
GND	15	16	Cut Pin

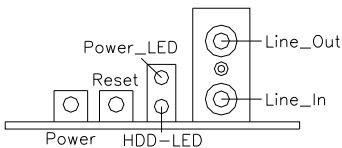
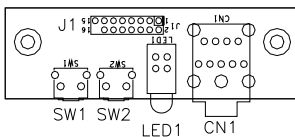

*Note:* Audio Line\_In connector for sound Recorder function only.

**J12: VGA Pin Header**

Connect the VGA8 CRT/VGA cable that comes with the board to J12.

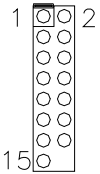

Signal Name	Pin	Pin	Signal Name
Red	1	2	VCC
Green	3	4	GND
Blue	5	6	N.C
N.C	7	8	DDCDA
GND	9	10	H_SYNC
GND	11	12	V_SYNC
GND	13	14	DDCCLK
GND	15	16	Cut Pin

**J13: CAN Bus Port1 Pin Header (Reserved)**

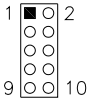

Signal Name	Pin	Pin	Signal Name
N,C	1	2	GND
CAN0_L	3	4	CAN0_H
GND	5	6	N.C
N.C	7	8	N.C
N.C	9	10	Cut Pin

**J14: COM2/3/4 is a 30-pin Header**

J14 is the board's 30-pin COM2/3/4 serial port (RS232) connector.

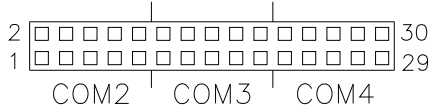

Signal Name	Pin #	Pin #	Signal Name
DCD2	1	2	DSR2
SIN2	3	4	RTS2
SO2	5	6	CTS2
DTR2-	7	8	RI2
GND	9	10	N/A
DCD3	11	12	DSR3
SIN3	13	14	RTS3
SOUT3	15	16	CTS3
DTR3	17	18	RI3-
GND	19	20	N/A
DCD4	21	22	DSR4
SIN4	23	24	RTS4
SOUT4	25	26	CTS4
DTR4	27	28	RI4
GND	29	30	Cut Pin

**J15: CAN Bus Port2 Pin Header (Reserved)**

Signal Name	Pin	Pin	Signal Name
N.C	1	2	GND
CAN1_L	3	4	CAN1_H
GND	5	6	N.C
N.C	7	8	N.C
N.C	9	10	Cut Pin

**J16: LPC 80 Port Pin Header (Debug Use Only)**

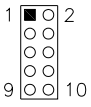

Signal Name	Pin	Pin	Signal Name
LAD0	1	2	PLTRST_N
LAD1	3	4	CLK33
LAD2	5	6	+3.3V
LAD3	7	8	L_FRAME_N
GND	9	10	Cut Pin

---

# BIOS Setup

This chapter describes the different settings available in the Award BIOS that comes with the board. The topics covered in this chapter are as follows:

BIOS Introduction .....	22
BIOS Setup.....	22
Standard CMOS Setup .....	24
Advanced BIOS Features .....	27
Advanced Chipset Features .....	30
Integrated Peripherals.....	31
Power Management Setup.....	34
PNP/PCI Configurations .....	37
PC Health Status.....	38
Frequency/Voltage Control .....	39
Load Fail-Safe Defaults.....	40
Load Optimized Defaults .....	40
Set Supervisor/User Password.....	40
Save & Exit Setup .....	40
Exit Without Saving .....	40

## BIOS Introduction

The Award BIOS (Basic Input/Output System) installed in your computer system's ROM supports Intel processors. The BIOS provides critical low-level support for a standard device such as disk drives, serial ports and parallel ports. It also adds virus and password protection as well as special support for detailed fine-tuning of the chipset controlling the entire system.

## BIOS Setup

The Award BIOS provides a Setup utility program for specifying the system configurations and settings. The BIOS ROM of the system stores the Setup utility. When you turn on the computer, the Award BIOS is immediately activated. Pressing the <Del> key immediately allows you to enter the Setup utility. If you are a little bit late pressing the <Del> key, POST (Power On Self Test) will continue with its test routines, thus preventing you from invoking the Setup. If you still wish to enter Setup, restart the system by pressing the "Reset" button or simultaneously pressing the <Ctrl>, <Alt> and <Delete> keys. You can also restart by turning the system Off and back On again. The following message will appear on the screen:

```
Press <DEL> to Enter Setup
```

In general, you press the arrow keys to highlight items, <Enter> to select, the <PgUp> and <PgDn> keys to change entries, <F1> for help and <Esc> to quit.

When you enter the Setup utility, the Main Menu screen will appear on the screen. The Main Menu allows you to select from various setup functions and exit choices.

## Phoenix - AwardBIOS CMOS Setup Utility

Standard CMOS Features	Frequency/Voltage Control
Advanced BIOS Features	Load Fail-Safe Defaults
Advanced Chipset Features	Load Optimized Defaults
Integrated Peripherals	Set Supervisor Password
Power Management Setup	Set User Password
PnP/PCI Configurations	Save & Exit Setup
PC Health Status	Exit Without Saving
ESC : Quit	↑ ↓ → ← : Select Item
F10 : Save & Exit Setup	
Time, Date, Hard Disk Type...	

The section below the setup items of the Main Menu displays the control keys for this menu. At the bottom of the Main Menu just below the control keys section, there is another section, which displays information on the currently highlighted item in the list.

**Note:** *If the system cannot boot after making and saving system changes with Setup, the Award BIOS supports an override to the CMOS settings that resets your system to its default.*

**Warning:** *It is strongly recommended that you avoid making any changes to the chipset defaults. These defaults have been carefully chosen by both Award and your system manufacturer to provide the absolute maximum performance and reliability. Changing the defaults could cause the system to become unstable and crash in some cases.*

## Standard CMOS Setup

“Standard CMOS Setup” choice allows you to record some basic hardware configurations in your computer system and set the system clock and error handling. If the motherboard is already installed in a working system, you will not need to select this option. You will need to run the Standard CMOS option, however, if you change your system hardware configurations, the onboard battery fails, or the configuration stored in the CMOS memory was lost or damaged.

Phoenix - AwardBIOS CMOS Setup Utility  
Standard CMOS Features

Date (mm:dd:yy)	Tue, Jul 1, 2008	Item Help
Time (hh:mm:ss)	12 : 00 : 00	Menu Level >
IDE Channel 0 Master	None	Change the day, month, Year and century
IDE Channel 0 Slave	None	
IDE Channel 1 Master	None	
IDE Channel 1 Slave	None	
Video	EGA/VGA	
Halt On	All Errors	
Base Memory	640K	
Extended Memory	1046528K	
Total Memory	1047552K	

At the bottom of the menu are the control keys for use on this menu. If you need any help in each item field, you can press the <F1> key. It will display the relevant information to help you. The memory display at the lower right-hand side of the menu is read-only. It will adjust automatically according to the memory changed. The following describes each item of this menu.

### Date

The date format is:

**Day :** Sun to Sat  
**Month :** 1 to 12  
**Date :** 1 to 31  
**Year :** 1999 to 2099

To set the date, highlight the “Date” field and use the PageUp/PageDown or +/- keys to set the current time.

### Time

The time format is: **Hour : 00 to 23**  
**Minute : 00 to 59**  
**Second : 00 to 59**

To set the time, highlight the “Time” field and use the <PgUp>/<PgDn> or +/- keys to set the current time.

### IDE Channel Master/Slave

The onboard PCI IDE connector provides Primary and Secondary channels for connecting up to two IDE hard disks or other IDE devices.

Press <Enter> to configure the hard disk. The selections include Auto, Manual, and None. Select ‘Manual’ to define the drive information manually. You will be asked to enter the following items.

**Capacity :** Capacity/size of the hard disk drive  
**Cylinder :** Number of cylinders  
**Head :** Number of read/write heads  
**Precomp :** Write precompensation  
**Landing Zone :** Landing zone  
**Sector :** Number of sectors

The Access Mode selections are as follows:

CHS (HD < 528MB)  
LBA (HD > 528MB and supports Logical Block Addressing)  
Large (for MS-DOS only)  
Auto

### Video

This field selects the type of video display card installed in your system.

You can choose the following video display cards:

EGA/VGA	For EGA, VGA, SEGA, SVGA or PGA monitor adapters. (default)
CGA 40	Power up in 40 column mode.
CGA 80	Power up in 80 column mode.
MONO	For Hercules or MDA adapters.

### Halt On

This field determines whether or not the system will halt if an error is detected during power up.

No errors	The system boot will not be halted for any error that may be detected.
All errors	Whenever the BIOS detects a non-fatal error, the system will stop and you will be prompted.
All, But Keyboard	The system boot will not be halted for a keyboard error; it will stop for all other errors
All, But Diskette	The system boot will not be halted for a disk error; it will stop for all other errors.
All, But Disk/Key	The system boot will not be halted for a keyboard or disk error; it will stop for all others.

## Advanced BIOS Features

This section allows you to configure and improve your system and allows you to set up some system features according to your preference.

Phoenix - AwardBIOS CMOS Setup Utility  
Advanced BIOS Features

		ITEM HELP
CPU Feature	Press Enter	
Hard Disk Boot Priority	Press Enter	
Virus Warning	Disabled	Menu Level >
CPU L1 & L2 Cache	Enabled	
Quick Power On Self Test	Enabled	
First Boot Device	Removable	
Second Boot Device	Hard Disk	
Third Boot Device	USB-CDROM	
Boot Other Device	Enabled	
Boot Up NumLock Status	On	
Gate A20 Option	Fast	
Typematic Rate Setting	Disabled	
Typematic Rate (Chars/Sec)	6	
Typematic Delay (Msec)	250	
Security Option	Setup	
APIC Mode	Enabled	
MPS Version Control for OS	1.4	
OS Select For DRAM>64MB	Non-OS2	
Small Logo (EPA) Show	Disabled	

### CPU Feature

Press Enter to configure the settings relevant to CPU Feature.

### Hard Disk Boot Priority

With the field, there is the option to choose, aside from the hard disks connected, "Bootable add-in Cards" which refers to other external devices.

### Virus Warning

If this option is enabled, an alarm message will be displayed when trying to write on the boot sector or on the partition table on the disk.

### CPU L1 and L2 Cache

Cache memory is additional memory that is faster than conventional DRAM (system memory). CPUs from 486-type on up contain internal cache memory, and most, but not all, modern PCs have additional (external) cache memory. When the CPU requests data, the system transfers the requested data from the main DRAM into cache memory, for even faster access by the CPU. These allow you to enable (speed up memory access) or disable the cache function.

### Quick Power On Self Test

When enabled, this field speeds up the Power On Self Test (POST) after the system is turned on. If it is set to *Enabled*, BIOS will skip some items.

### **First/Second/Third Boot Device**

These fields determine the drive that the system searches first for an operating system. The options available include *Removable*, *Hard Disk*, *CDROM*, *USB-CDROM* and *Disable*.

### **Boot Other Device**

These fields allow the system to search for an OS from other devices other than the ones selected in the First/Second/Third Boot Device.

### **Boot Up NumLock Status**

This allows you to activate the NumLock function after you power up the system.

### **Gate A20 Option**

This field allows you to select how Gate A20 is worked. Gate A20 is a device used to address memory above 1 MB.

### **Typematic Rate Setting**

When disabled, continually holding down a key on your keyboard will generate only one instance. When enabled, you can set the two typematic controls listed next. By default, this field is set to *Disabled*.

### **Typematic Rate (Chars/Sec)**

When the typematic rate is enabled, the system registers repeated keystrokes speeds. Settings are from 6 to 30 characters per second.

### **Typematic Delay (Msec)**

When the typematic rate is enabled, this item allows you to set the time interval for displaying the first and second characters. By default, this item is set to *250msec*.

### **Security Option**

This field allows you to limit access to the System and Setup. The default value is *Setup*. When you select *System*, the system prompts for the User Password every time you boot up. When you select *Setup*, the system always boots up and prompts for the Supervisor Password only when the Setup utility is called up.

### **APIC Mode**

APIC stands for Advanced Programmable Interrupt Controller. The default setting is *Enabled*.

**MPS Version Control for OS**

This option specifies the MPS (Multiprocessor Specification) version for your operating system. MPS version 1.4 added extended configuration tables to improve support for multiple PCI bus configurations and improve future expandability. The default setting is *1.4*.

**OS Select for DRAM > 64MB**

This option allows the system to access greater than 64MB of DRAM memory when used with OS/2 that depends on certain BIOS calls to access memory. The default setting is *Non-OS/2*.

**Small Logo (EPA) Show**

The EPA logo appears at the right side of the monitor screen when the system is boot up. The default setting is *Disabled*.

## Advanced Chipset Features

This Setup menu controls the configuration of the chipset.

Phoenix - AwardBIOS CMOS Setup Utility  
Advanced Chipset Features

System BIOS Cacheable	Enabled	ITEM HELP
Video BIOS Cacheable	Disabled	Menu Level >
Memory Hole at 15M-16M	Disabled	
IICH PCI Express Root Port	Press Enter	

### System BIOS Cacheable

The setting of *Enabled* allows caching of the system BIOS ROM at F000h-FFFFFh, resulting in better system performance. However, if any program writes to this memory area, a system error may result.

### Video BIOS Cacheable

The Setting *Enabled* allows caching of the video BIOS ROM at C0000h-F7FFFh, resulting in better video performance. However, if any program writes to this memory area, a system error may result.

### Memory Hole At 15M-16M

In order to improve performance, certain space in memory can be reserved for ISA cards. This memory must be mapped into the memory space below 16 MB. The choices are *Enabled* and *Disabled*.

## Integrated Peripherals

This section sets configurations for your hard disk and other integrated peripherals. The first screen shows three main items for user to select. Once an item selected, a submenu appears. Details follow.

Phoenix - AwardBIOS CMOS Setup Utility  
Integrated Peripherals

OnChip IDE Device	Press Enter	ITEM HELP
Onboard Device	Press Enter	Menu Level >
SuperIO Device	Press Enter	
ICH Serial Port 1	3E8/IRQ5	
ICH Serial Port 2	2E8/IRQ7	

Phoenix - AwardBIOS CMOS Setup Utility  
OnChip IDE Device

IDE HDD Block Mode	Enabled	ITEM HELP
IDE DMA transfer access	Enabled	Menu Level >
On-Chip Primary PCI IDE	Enabled	
IDE Primary Master PIO	Auto	
IDE Primary Slave PIO	Auto	
IDE Primary Master UDMA	Auto	
IDE Primary Slave UDMA	Auto	
On-Chip Secondary PCI IDE	Enabled	
IDE Secondary Master PIO	Auto	
IDE Secondary Slave PIO	Auto	
IDE Secondary Master UDMA	Auto	
IDE Secondary Slave UDMA	Auto	
*** On-Chip Serial ATA Setting ***		
On-Chip Serial ATA	IDE	

Phoenix - AwardBIOS CMOS Setup Utility  
Onboard Device

USB Controller	Enabled	ITEM HELP
USB 2.0 Controller	Enabled	Menu Level >
USB Keyboard Function	Disabled	
USB Mouse Function	Disabled	

Phoenix - AwardBIOS CMOS Setup Utility  
SuperIO Device

POWER ON Function	BUTTON ONLY	ITEM HELP
KB Power ON Password	Enter	Menu Level >
Hot Key power ON	Ctrl-F1	
Onboard Serial Port 1	3F8/IRQ4	
Onboard Serial Port 2	2F8/IRQ3	
PWRON After PWR-Fail	Off	

### **IDE HDD Block Mode**

This field allows your hard disk controller to use the fast block mode to transfer data to and from your hard disk drive.

### **IDE DMA transfer access**

Use this field to enable or disable IDE DMA transfer access.

### **On-chip Primary PCI IDE Enabled**

This field, by default, is enabled

### **On-chip Primary/Secondary PCI IDE**

The integrated peripheral controller contains an IDE interface with support for two IDE channels. Select *Enabled* to activate each channel separately.

### **IDE Primary/Secondary Master/Slave PIO**

These fields allow your system hard disk controller to work faster. Rather than have the BIOS issue a series of commands that transfer to or from the disk drive, PIO (Programmed Input/Output) allows the BIOS to communicate with the controller and CPU directly.

The system supports five modes, numbered from 0 (default) to 4, which primarily differ in timing. When Auto is selected, the BIOS will select the best available mode.

### **IDE Primary/Secondary Master/Slave UDMA**

These fields allow your system to improve disk I/O throughput to 33Mb/sec with the Ultra DMA/33 feature. The options are *Auto* and *Disabled*.

### **USB Controller**

The options for this field are *Enabled* and *Disabled*. By default, this field is set to *Enabled*.

### **USB 2.0 Controller**

The options for this field are *Enabled* and *Disabled*. By default, this field is set to *Enabled*. In order to use USB 2.0, necessary OS drivers must be installed first.

### **USB Keyboard/Mouse Support**

The options for this field are *Enabled* and *Disabled*. By default, this field is set to *Disabled*.

**Power ON Function**

This field is related to how the system is powered on – such as with the use of conventional power button, keyboard or hot keys. The default is **BUTTON ONLY**.

**KB Power ON Password**

This field allows users to set the password when keyboard power on is the mode of the Power ON function.

**Hot Key Power ON**

This field sets certain keys, also known as hot keys, on the keyboard that can be used as a ‘switch’ to power on the system.

**Onboard Serial Port/ICH Serial Port**

These fields allow you to select the onboard serial and parallel ports and their addresses. The default values for these ports are:

Onboard Serial Port 1	3F8/IRQ4
Onboard Serial Port 2	2F8/IRQ3
ICH Serial Port 1	3E8/IRQ5
ICH Serial Port 2	2E8/IRQ7

**PWRON After PWR-Fail**

This field sets the system power status whether *on or off* when power returns to the system from a power failure situation.

## Power Management Setup

Phoenix - AwardBIOS CMOS Setup Utility  
Power Management Setup

ACPI Function	Enabled	ITEM HELP
ACPI Suspend	S1(POS)	Menu Level >
RUN VGABIOS if S3 Resume	Auto	
Power Management	User Define	
Video Off Method	V/H SYNC+Blank	
Video Off In Suspend	Yes	
Suspend Type	Stop Grant	
Modem Use IRQ	3	
Suspend Mode	Disabled	
HDD Power Down	Disabled	
Soft-Off by PWR-BTTN	Instant-Off	
Power On by Ring	Disabled	
Resume by Alarm	Disabled	
Date (of Month) Alarm	0	
Time (hh:mm:ss) Alarm	0 : 0 : 0	
** Reload Global Timer Events **		
Primary IDE 0	Enabled	
Primary IDE 1	Enabled	
Secondary IDE 0	Enabled	
Secondary IDE 1	Enabled	
FDD, COM, LPT Port	Enabled	
PCI PIRQ[A-D] #	Enabled	

### ACPI Function

Enable this function to support ACPI (Advance Configuration and Power Interface).

### ACPI Suspend

The default setting of the ACPI Suspend mode is *SI(POS)*.

### RUN VGABIOS if S3 Resume

The default setting of this field is *Auto*.

### Power Management

This field allows you to select the type of power saving management modes. There are four selections for Power Management.

Min. Power Saving	Minimum power management
Max. Power Saving	Maximum power management.
User Define	Each of the ranges is from 1 min. to 1hr. Except for HDD Power Down which ranges from 1 min. to 15 min.

**Video Off Method**

This field defines the Video Off features. There are three options.

V/H SYNC + Blank	Default setting, blank the screen and turn off vertical and horizontal scanning.
DPMS	Allows BIOS to control the video display.
Blank Screen	Writes blanks to the video buffer.

**Video Off In Suspend**

When enabled, the video is off in suspend mode. The default setting is *Yes*.

**Suspend Type**

The default setting for the Suspend Type field is *Stop Grant*.

**Modem Use IRQ**

This field sets the IRQ used by the Modem. By default, the setting is **3**.

**Suspend Mode**

When enabled, and after the set time of system inactivity, all devices except the CPU will be shut off.

**HDD Power Down**

When enabled, and after the set time of system inactivity, the hard disk drive will be powered down while all other devices remain active.

**Soft-Off by PWRBTN**

This field defines the power-off mode when using an ATX power supply. The *Instant Off* mode allows powering off immediately upon pressing the power button. In the *Delay 4 Sec* mode, the system powers off when the power button is pressed for more than four seconds or enters the suspend mode when pressed for less than 4 seconds.

**CPU THRM-Throttling**

When the system enters Doze mode, the CPU clock runs only part of the time. You may select the percent of time that the clock runs.

**Power On by Ring**

This field enables or disables the power on of the system through the modem connected to the serial port or LAN.

### **Resume by Alarm**

This field enables or disables the resumption of the system operation. When enabled, the user is allowed to set the *Date* and *Time*.

### **Reload Global Timer Events**

The HDD, FDD, COM, LPT Ports, and PCI PIRQ are I/O events that can prevent the system from entering a power saving mode or can awaken the system from such a mode. When an I/O device wants to gain the attention of the operating system, it signals this by causing an IRQ to occur. When the operating system is ready to respond to the request, it interrupts itself and performs the service.

## PNP/PCI Configurations

This option configures the PCI bus system. All PCI bus systems on the system use INT#, thus all installed PCI cards must be set to this value.

Phoenix - AwardBIOS CMOS Setup Utility  
PnP/PCI Configurations

Init Display First	PCI Slot	ITEM HELP
Reset Configuration Data	Disabled	Menu Level >
Resources Controlled By	Auto (ESCD)	
IRQ Resources	Press Enter	
PCI/VGA Palette Snoop	Disabled	
**PCI Express relative items**		
Maximum Payload Size	4096	

### Init Display First

The default setting is *PCI Card*.

### Reset Configuration Data

This field allows you to determine whether to reset the configuration data or not. The default value is *Disabled*.

### Resources Controlled by

This PnP BIOS can configure all of the boot and compatible devices with the use of a PnP operating system such as Windows 95.

### PCI/VGA Palette Snoop

Some non-standard VGA display cards may not show colors properly. This field allows you to set whether or not MPEG ISA/VESA VGA cards can work with PCI/VGA. When this field is enabled, a PCI/VGA can work with an MPEG ISA/VESA VGA card. When this field is disabled, a PCI/VGA cannot work with an MPEG ISA/VESA card.

### Maximum Payload Size

The default setting of the PCI Express Maximum Payload Size is 4096.

## PC Health Status

This section shows the parameters in determining the PC Health Status. These parameters include temperatures, fan speeds and voltages.

Phoenix - AwardBIOS CMOS Setup Utility  
PC Health Status

		ITEM HELP
CPU Warning Temperature	Disabled	Menu Level >
Current System Temp	47°C/116°F	
Current CPU Temp	47°C/116°F	
CPU FAN Speed	5400 RPM	
Vcore	1.30 V	
12 V	12.34 V	
1.8V	1.89V	
5V	4.99 V	
3.3V	3.15V	
VBAT (V)	3.15 V	
5VSB(V)	5.31 V	

### CPU Warning Temperature

This field allows the user to set the temperature so that when the temperature is reached, the system sounds a warning. This function can help prevent damage to the system that is caused by overheating.

### Temperatures/Voltages

These fields are the parameters of the hardware monitoring function feature of the motherboard. The values are read-only values as monitored by the system and show the PC health status.

## Frequency/Voltage Control

This section shows the user how to configure the processor frequency.

Phoenix - AwardBIOS CMOS Setup Utility  
Frequency/Voltage Control

Auto Detect PCI Clk	Disabled	ITEM HELP
Spread Spectrum Modulated	Disabled	Menu Level >

### Auto Detect PCI Clk

This field enables or disables the auto detection of the PCI clock.

### Spread Spectrum Modulated

This field sets the value of the spread spectrum. The default setting is *Disabled*. This field is for CE testing use only.

### **Load Fail-Safe Defaults**

This option allows you to load the troubleshooting default values permanently stored in the BIOS ROM. These default settings are non-optimal and disable all high-performance features.

### **Load Optimized Defaults**

This option allows you to load the default values to your system configuration. These default settings are optimal and enable all high performance features.

### **Set Supervisor Password**

These two options set the system password. Supervisor Password sets a password that will be used to protect the system and Setup utility. User Password sets a password that will be used exclusively on the system. To specify a password, highlight the type you want and press <Enter>. The Enter Password: message prompts on the screen. Type the password, up to eight characters in length, and press <Enter>. The system confirms your password by asking you to type it again. After setting a password, the screen automatically returns to the main screen.

To disable a password, just press the <Enter> key when you are prompted to enter the password. A message will confirm the password to be disabled. Once the password is disabled, the system will boot and you can enter Setup freely.

### **Save & Exit Setup**

This option allows you to determine whether or not to accept the modifications. If you type “Y”, you will quit the setup utility and save all changes into the CMOS memory. If you type “N”, you will return to Setup utility.

### **Exit Without Saving**

Select this option to exit the Setup utility without saving the changes you have made in this session. Typing “Y” will quit the Setup utility without saving the modifications. Typing “N” will return you to Setup utility.

# Drivers Installation

## Intel® EP80579 Software Drivers for Embedded Applications

Intel® EP80579 Software Drivers for Embedded Applications contains all software drivers needed to utilize hardware features on the Intel® EP80579 Integrated Processor.

In addition to the standard OS drivers offered with other Intel architecture platforms, this software package contains drivers specific to developing embedded applications. These drivers provide access to and control of the three Ethernet MACs and two Controller Area Network (CAN) interfaces, as well as internal processor items such as Enhanced Direct Memory Access (EDMA).

Because the core of the Intel EP80579 Integrated Processor is based on Intel architecture, operating systems currently supporting Intel architecture will function without this software package.

For the most recent software package updates from Intel, please visit [downloadcenter.intel.com](http://downloadcenter.intel.com).

- The following operating systems are supported on the Intel EP80579 Integrated Processor:
  - Microsoft Windows XP\* Embedded SP2
  - Red Hat Enterprise Linux\* 5
  - Wind River Linux\* 2.0
  - Wind River VxWorks\* 6.6
  - FreeBSD\* 6.2

**The Driver CD that comes with the board contains software drivers for Windows XP Embedded and Linux.**

**For all the related drivers, please go to Driver CD \intel\EP80579 folder.**

This page is intentionally left blank.

# Appendix

## A. Watchdog Timer Configuration

The WDT is used to generate a variety of output signals after a user programmable count. The WDT is suitable for use in the prevention of system lock-up, such as when software becomes trapped in a deadlock. Under these sorts of circumstances, the timer will count to zero and the selected outputs will be driven. Under normal circumstance, the user will restart the WDT at regular intervals before the timer counts to zero.

### SAMPLE CODE:

```

=====
//
// THIS CODE AND INFORMATION IS PROVIDED "AS IS" WITHOUT WARRANTY OF ANY
// KIND, EITHER EXPRESSED OR IMPLIED, INCLUDING BUT NOT LIMITED TO THE
// IMPLIED WARRANTIES OF MERCHANTABILITY AND/OR FITNESS FOR A PARTICULAR
// PURPOSE.
//
=====
#include <stdio.h>
#include <stdlib.h>
#include "W627EHG.H"
=====
int main (int argc, char *argv[]);
void copyright(void);
void EnableWDT(int);
void DisableWDT(void);
=====
int main (int argc, char *argv[])
{
    unsigned char bBuf;
    unsigned char bTime;
    char **endptr;

    copyright();

    if (argc != 2)
    {
        printf(" Parameter incorrect!!\n");
        return 1;
    }

    if (Init_W627EHG() == 0)
    {
        printf(" Winbond 83627HF is not detected, program abort.\n");
        return 1;
    }
    bTime = strtol (argv[1], endptr, 10);
    printf("System will reset after %d seconds\n", bTime);

    EnableWDT(bTime);

    return 0;
}
=====

```

```
void copyright(void)
{
    printf("\n===== Winbond 83627EHG Watch Timer Tester (AUTO DETECT) =====\n")
        " Usage : W627E_WD reset_time\n"
        " Ex : W627E_WD 3 => reset system after 3 second\n"
        " W627E_WD 0 => disable watch dog timer\n");
}
//=====
void EnableWDT(int interval)
{
    unsigned char bBuf;

    bBuf = Get_W627EHG_Reg( 0x2D);
    bBuf &= (10x01);
    Set_W627EHG_Reg( 0x2D, bBuf); //Enable WDTO

    Set_W627EHG_LD( 0x08); //switch to logic device 8
    Set_W627EHG_Reg( 0x30, 0x01); //enable timer

    bBuf = Get_W627EHG_Reg( 0xF5);
    bBuf &= (10x08);
    Set_W627EHG_Reg( 0xF5, bBuf); //count mode is second

    Set_W627EHG_Reg( 0xF6, interval); //set timer
}
//=====
void DisableWDT(void)
{
    Set_W627EHG_LD(0x08); //switch to logic device 8
    Set_W627EHG_Reg(0xF6, 0x00); //clear watchdog timer
    Set_W627EHG_Reg(0x30, 0x00); //watchdog disabled
}
//=====
```

```

//=====
//
// THIS CODE AND INFORMATION IS PROVIDED "AS IS" WITHOUT WARRANTY OF ANY
// KIND, EITHER EXPRESSED OR IMPLIED, INCLUDING BUT NOT LIMITED TO THE
// IMPLIED WARRANTIES OF MERCHANTABILITY AND/OR FITNESS FOR A PARTICULAR
// PURPOSE.
//
//=====
#include "W627EHG.H"
#include <dos.h>
//=====
unsigned int W627EHG_BASE;
void Unlock_W627EHG (void);
void Lock_W627EHG (void);
//=====
unsigned int Init_W627EHG(void)
{
    unsigned int result;
    unsigned char ucDid;

    W627EHG_BASE = 0x2E;
    result = W627EHG_BASE;

    ucDid = Get_W627EHG_Reg(0x20);
    if (ucDid == 0x88)
    {
        goto Init_Finish;
    }

    W627EHG_BASE = 0x4E;
    result = W627EHG_BASE;
    ucDid = Get_W627EHG_Reg(0x20);
    if (ucDid == 0x88)
    {
        goto Init_Finish;
    }

    W627EHG_BASE = 0x00;
    result = W627EHG_BASE;

Init_Finish:
    return (result);
}
//=====
void Unlock_W627EHG (void)
{
    outportb(W627EHG_INDEX_PORT, W627EHG_UNLOCK);
    outportb(W627EHG_INDEX_PORT, W627EHG_UNLOCK);
}
//=====
void Lock_W627EHG (void)
{
    outportb(W627EHG_INDEX_PORT, W627EHG_LOCK);
}
//=====
void Set_W627EHG_LD( unsigned char LD)
{
    Unlock_W627EHG();
    outportb(W627EHG_INDEX_PORT, W627EHG_REG_LD);
    outportb(W627EHG_DATA_PORT, LD);
    Lock_W627EHG();
}

```

## APPENDIX

---

```
//=====
void Set_W627EHG_Reg( unsigned char REG, unsigned char DATA)
{
    Unlock_W627EHG();
    outportb(W627EHG_INDEX_PORT, REG);
    outportb(W627EHG_DATA_PORT, DATA);
    Lock_W627EHG();
}
//=====
unsigned char Get_W627EHG_Reg(unsigned char REG)
{
    unsigned char Result;
    Unlock_W627EHG();
    outportb(W627EHG_INDEX_PORT, REG);
    Result = inportb(W627EHG_DATA_PORT);
    Lock_W627EHG();
    return Result;
}
//=====

//=====
//
// THIS CODE AND INFORMATION IS PROVIDED "AS IS" WITHOUT WARRANTY OF ANY
// KIND, EITHER EXPRESSED OR IMPLIED, INCLUDING BUT NOT LIMITED TO THE
// IMPLIED WARRANTIES OF MERCHANTABILITY AND/OR FITNESS FOR A PARTICULAR
// PURPOSE.
//
//=====
#ifndef __W627EHG_H
#define __W627EHG_H                1
//=====
#define W627EHG_INDEX_PORT      (W627EHG_BASE)
#define W627EHG_DATA_PORT      (W627EHG_BASE+1)
//=====
#define W627EHG_REG_LD          0x07
//=====
#define W627EHG_UNLOCK          0x87
#define W627EHG_LOCK            0xAA
//=====
unsigned int Init_W627EHG(void);
void Set_W627EHG_LD( unsigned char);
void Set_W627EHG_Reg( unsigned char, unsigned char);
unsigned char Get_W627EHG_Reg( unsigned char);
//=====
#endif // __W627EHG_H
```